

ServerDOM-H

3SE Series

Customer: _____

Customer

Part

Number: _____

Innodisk

Part

Number: _____

Innodisk

Model Name: _____

Date: _____

Innodisk Approver	Customer Approver

**Total Solution For
Industrial Flash Storage**

Table of contents

LIST OF FIGURES	6
1. PRODUCT OVERVIEW	7
1.1 INTRODUCTION OF INNODISK SERVERDOM-H 3SE	7
1.2 PRODUCT VIEW AND MODELS	7
1.3 SATA INTERFACE	7
2. PRODUCT SPECIFICATIONS	8
2.1 CAPACITY AND DEVICE PARAMETERS	8
2.2 PERFORMANCE	8
2.3 ELECTRICAL SPECIFICATIONS	8
2.3.1 Power Requirement	8
2.3.2 Power Consumption	8
2.4 ENVIRONMENTAL SPECIFICATIONS	9
2.4.1 Temperature Ranges	9
2.4.2 Humidity	9
2.4.3 Shock and Vibration	9
2.4.4 Mean Time between Failures (MTBF)	9
2.5 CE AND FCC COMPATIBILITY	9
2.6 RoHS COMPLIANCE	10
2.7 RELIABILITY	10
2.8 TRANSFER MODE	10
2.9 PIN ASSIGNMENT	10
2.10 MECHANICAL DIMENSIONS	11
2.11 ASSEMBLY WEIGHT	11
2.12 SEEK TIME	11
2.13 HOT PLUG	11
2.14 NAND FLASH MEMORY	11
3. THEORY OF OPERATION	12
3.1 OVERVIEW	12
3.2 SATA III CONTROLLER	12
3.3 ERROR DETECTION AND CORRECTION	12
3.4 WEAR-LEVELING	13
3.5 BAD BLOCKS MANAGEMENT	13
3.6 POWER CYCLING	13
3.7 GARBAGE COLLECTION	13
4. INSTALLATION REQUIREMENTS	14
4.1 SERVERDOM-H 3SE PIN DIRECTIONS	14

4.2 ELECTRICAL CONNECTIONS FOR SERVERDOM-H 3SE	14
4.3 DEVICE DRIVE	14
4.4 PIN7 VCC	14
4.6 POWER CABLE	15
5. PART NUMBER RULE	16

REVISION HISTORY

Revision	Description	Date
Preliminary	First Released	FEB, 2015
1.0	Add CE/FCC certification	AUG, 2015
1.01	Modified performance	SEP, 2015
1.02	Modify performance Add iDataGuard information Modify the part number rule	Dec, 2015
1.03	Modify the mechanical dimension	Nov, 2016

List of Tables

TABLE 1: DEVICE PARAMETERS	8
TABLE 2: PERFORMANCE	8
TABLE 3: INNODISK SERVERDOM-H 3SE POWER REQUIREMENT	8
TABLE 4: POWER CONSUMPTION	8
TABLE 5: TEMPERATURE RANGE FOR SERVERDOM-H 3SE	9
TABLE 6: SHOCK/VIBRATION TESTING FOR SERVERDOM-H 3SE	9
TABLE 7: SERVERDOM-H 3SE MTBF	9
TABLE 8: INNODISK SERVERDOM-H 3SE PIN ASSIGNMENT	10

List of Figures

FIGURE 1: INNODISK SERVERDOM-H 3SE	7
FIGURE 2: INNODISK SERVERDOM-H 3SE BLOCK DIAGRAM.....	12
FIGURE 3: SATA SIGNAL SEGMENT & HOST MALE PIN8 SIGNAL SEGMENT.....	14

1. Product Overview

1.1 Introduction of Innodisk SERVERDOM-H 3SE

Innodisk ServerDOM is dedicated to the further of server design. By using ServerDOM as a boot drive, there is more space for the hot-swappable data storage devices.

Innodisk ServerDOM supports SATA III standard (6.0Gb/s) interface with excellent performance and the innovative Pin8 uses the SATA connector itself as a power supply to drive the device without external cables. It could be connected directly to the SATA on-board socket on customers' system without additional power cable. Besides, the booting time for operation and the power consumption is less than hard disk drive (HDD), and can work under harsh environment compile with ATA protocol, no additional drives are required, and the SSD can be configured as a boot device or data storage device.

1.2 Product View and Models

Innodisk SERVERDOM-H 3SE is available in follow capacities~

SERVERDOM-H 3SE 2GB, 4GB, 8GB, 16GB



Figure 1: Innodisk SERVERDOM-H 3SE

1.3 SATA Interface

Innodisk SERVERDOM-H 3SE supports SATA III interface, and compliant with SATA I and SATA II. SATA III interface can work with Serial Attached SCSI (SAS) host system, which is used in server computer. Innodisk SERVERDOM-H 3SE is compliant with Serial ATA Gen 1, Gen 2 and Gen 3 specification (Gen 3 supports 1.5Gbps /3.0Gbps/6.0Gbps data rate). SATA connector uses a standard 7-pin signal segment.

2. Product Specifications

2.1 Capacity and Device Parameters

SERVERDOM-H 3SE device parameters are shown in Table 1.

Table 1: Device parameters

Item	Capacity	Cylinder	Head	Sector	LBA
ServerDOM 3SE	2GB	16	63	3897	3928176
	4GB	16	63	7773	7835184
	8GB	16	63	15525	15649200
	16GB	16	63	16383	31277232

2.2 Performance

Burst Transfer Rate: 6.0Gbps

Table 2: Performance

Item		2GB	4GB	8GB	16GB
ServerDOM 3SE	Sequential Read	110 MB/s	220 MB/s	340 MB/s	450 MB/s
	Sequential Write	28 MB/s	55 MB/s	110 MB/s	200 MB/s

Note: the information is based on CrystalDiskMark 3.01 with file size 1000MB test patent

2.3 Electrical Specifications

2.3.1 Power Requirement

Table 3: Innodisk SERVERDOM-H 3SE Power Requirement

Item	Symbol	Rating	Unit
Input voltage	V _{IN}	+5 DC +- 5%	V

2.3.2 Power Consumption

Table 4: Power Consumption

Item	SLC	SLC	SLC	SLC
	2GB	4GB	8GB	16GB
Read (W)	1.0	1.3	1.5	1.7
Write(W)	0.9	1.1	1.3	2.0

Idle(W)	0.6	0.6	0.7	0.7
---------	-----	-----	-----	-----

2.4 Environmental Specifications

2.4.1 Temperature Ranges

Table 5: Temperature range for SERVERDOM-H 3SE

Temperature	Range
Operating	Standard Grade: 0°C to +70°C
	Industrial Grade: -40°C to +85°C <i>*The industrial grade is only available in SLC item.</i>
Storage	-55°C to +95°C

2.4.2 Humidity

Relative Humidity: 10-95%, non-condensing

2.4.3 Shock and Vibration

Table 6: Shock/Vibration Testing for SERVERDOM-H 3SE

Reliability	Test Conditions	Reference Standards
Vibration	7 Hz to 2K Hz, 20G, 3 axes	IEC 68-2-6
Mechanical Shock	Duration: 0.5ms, 1500 G, 3 axes	IEC 68-2-27

2.4.4 Mean Time between Failures (MTBF)

Table 7 summarizes the MTBF prediction results for various SERVERDOM-H 3SE configurations. The analysis was performed using a RAM Commander™ failure rate prediction.

- **Failure Rate:** The total number of failures within an item population, divided by the total number of life units expended by that population, during a particular measurement interval under stated condition.
- **Mean Time between Failures (MTBF):** A basic measure of reliability for repairable items: The mean number of life units during which all parts of the item perform within their specified limits, during a particular measurement interval under stated conditions.

Table 7: SERVERDOM-H 3SE MTBF

Product	Condition	MTBF (Hours)
Innodisk SERVERDOM-H 3SE	Telcordia SR-332 GB, 25°C	>3,000,000

2.5 CE and FCC Compatibility

SERVERDOM-H 3SE conforms to CE and FCC requirements.

2.6 RoHS Compliance

SERVERDOM-H 3SE is fully compliant with RoHS directive.

2.7 Reliability

Parameter	Value
Read Cycles	Unlimited Read Cycles
Wear-Leveling Algorithm	Support
Bad Blocks Management	Support
Error Correct Code	Support

Item	SLC 2GB	SLC 4GB	SLC 8GB	SLC 16GB
TBW (Sequential)	108	216	432	864

2.8 Transfer Mode

SERVERDOM-H 3SE support following transfer mode:

Serial ATA III 6.0Gbps

Serial ATA II 3.0Gbps

Serial ATA I 1.5Gbps

2.9 Pin Assignment

Innodisk SERVERDOM-H 3SE uses a standard SATA pin-out. See Table 8 for SERVERDOM-H 3SE pin assignment.

Table 8: Innodisk SERVERDOM-H 3SE Pin Assignment

Name	Type	Description
Pin 0	GND	Shielding
Pin 1	GND	Shielding
Pin 2	A+	Differential signal to A
Pin 3	A-	Differential signal to A-
Pin 4	GND	Shielding
Pin 5	B-	Differential signal to B-
Pin 6	B+	Differential signal to B
Pin 7	GND/VCC	Shielding/ Power
Pin 8	VCC (+5V)	Power

2.10 Mechanical Dimensions

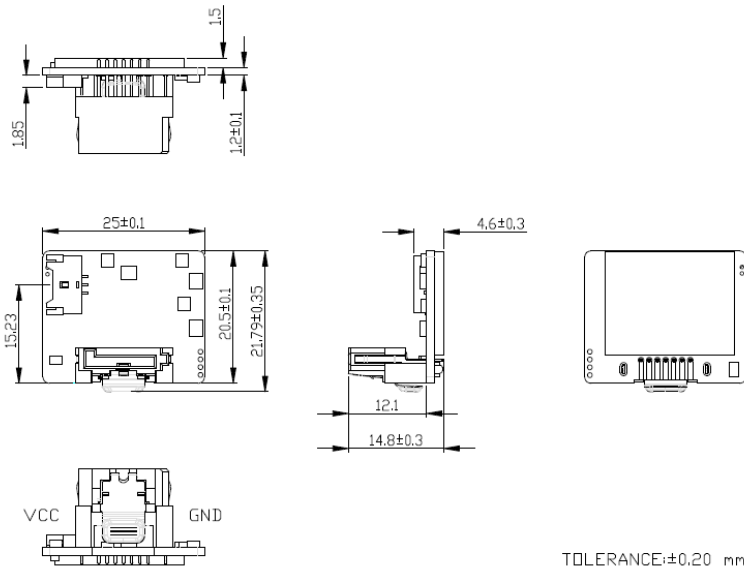

2.11 Assembly Weight

An Innodisk SERVERDOM-H 3SE within flash ICs, 64GB's weight is 8 grams approximately.

2.12 Seek Time

Innodisk SERVERDOM-H 3SE is not a magnetic rotating design. There is no seek or rotational latency required.

2.13 Hot Plug

The SSD support hot plug function and can be removed or plugged-in during operation. User has to avoid hot plugging the SSD which is configured as boot device and installed operation system.

Surprise hot plug : The insertion of a SATA device into a backplane (combine signal and power) that has power present. The device powers up and initiates an OOB sequence.

Surprise hot removal: The removal of a SATA device from a powered backplane, without first being placed in a quiescent state.

2.14 NAND Flash Memory

Innodisk SERVERDOM-H 3SE uses NAND flashes memory, which is non-Volatility, high reliability and high speed memory storage. Each cell stores 1~2 bits or holds four states per cell. Read or Write data to flash memory for SSD is control by microprocessor.

3. Theory of Operation

3.1 Overview

Figure 2 shows the operation of Innodisk SERVERDOM-H 3SE from the system level, including the major hardware blocks.

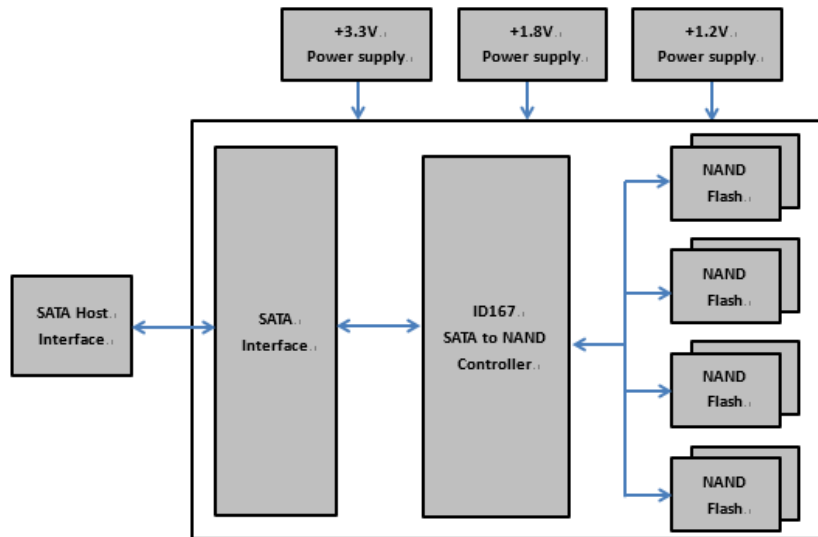

Figure 2: Innodisk SERVERDOM-H 3SE Block Diagram

Innodisk SERVERDOM-H 3SE integrates a SATA III controller and NAND flash memories. Communication with the host occurs through the host interface, using the standard ATA protocol. Communication with the flash device(s) occurs through the flash interface.

3.2 SATA III Controller

Innodisk SERVERDOM-H 3SE is designed with ID 107, a SATA III 6.0Gbps (Gen. 3) controller. The Serial ATA physical, link and transport layers are compliant with Serial ATA Gen 1, Gen 2 and Gen 3 specification (Gen 3 supports 1.5Gbps/3.0Gbps/6.0Gbps data rate). The controller has 2 channels for flash interface.

3.3 Error Detection and Correction

Highly sophisticated Error Correction Code algorithms are implemented. The ECC unit consists of the Parity Unit (parity-byte generation) and the Syndrome Unit (syndrome-byte computation). This unit implements an algorithm that can correct 40 bits per 1024 bytes in an ECC block. Code-byte generation during write operations, as well as error detection during read operation, is implemented on the fly without any speed penalties.

3.4 Wear-Leveling

Flash memory can be erased within a limited number of times. This number is called the **erase cycle limit** or **write endurance limit** and is defined by the flash array vendor. The erase cycle limit applies to each individual erase block in the flash device.

Innodisk SERVERDOM-H 3SE uses a static wear-leveling algorithm to ensure that consecutive writes of a specific sector are not written physically to the same page/block in the flash. This spreads flash media usage evenly across all pages, thereby extending flash lifetime.

3.5 Bad Blocks Management

Bad Blocks are blocks that contain one or more invalid bits whose reliability are not guaranteed. The Bad Blocks may be presented while the SSD is shipped, or may develop during the life time of the SSD. When the Bad Blocks is detected, it will be flagged, and not be used anymore. The SSD implement Bad Blocks management, Bad Blocks replacement, Error Correct Code to avoid data error occurred. The functions will be enabled automatically to transfer data from Bad Blocks to spare blocks, and correct error bit.

3.6 Power Cycling

Innodisk's iDataGuard is a comprehensive data protection mechanism that functions before and after a sudden power outage to SSD. Low-power detection terminates data writing before an abnormal power-off, while table-remapping after power-on deletes corrupt data and maintains data integrity. Innodisk's iDataGuard provides effective power cycling management, preventing data stored in flash from degrading with use.

3.7 Garbage Collection

Garbage collection is used to maintain data consistency and perform continual data cleansing on SSDs. It runs as a background process, freeing up valuable controller resources while sorting good data into available blocks, and deleting bad blocks. It also significantly reduces write operations to the drive, thereby increasing the SSD's speed and lifespan.

4. Installation Requirements

4.1 SERVERDOM-H 3SE Pin Directions

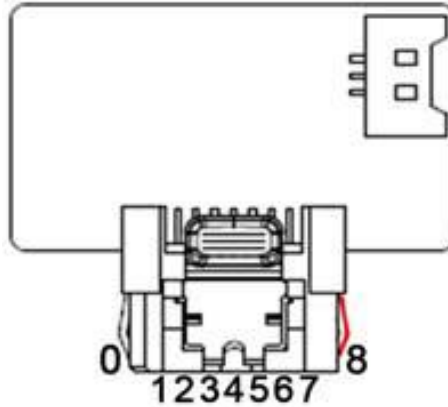

**ServerDOM with cable-less power supply feature has different part number!*

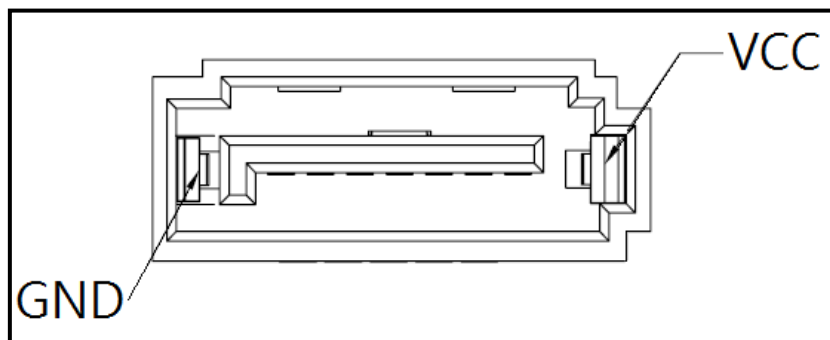

Figure 3: SATA signal segment & Host male Pin8 signal segment

4.2 Electrical Connections for SERVERDOM-H 3SE

A Serial ATA device may be either directly connected to a host or connected to a host through a cable. For connection via cable, the cable should be no longer than 1meter. The SATA interface has a separate connector for the power supply. Please refer to the pin description for further details.

4.3 Device Drive

No additional device drives are required. The Innodisk SERVERDOM-H 3SE can be configured as a boot device.

4.4 Pin7 VCC

Innodisk SATADOM series products have an optional design to provide power supply through the 7th Pin of SATA connector, and customers DO NOT have to use the power cable for power supply. Such a cable-less design of SATADOM series products with Pin7 VCC brings more convenience to

customers' system. The followings are the points customers have to be careful of while designing in SATADOM series products with Pin7 VCC.

SATADOM series products with Pin7 VCC is designed with a fuse (poly switch 500mA, 6V) on Pin7's circuit. Such a design could avoid any potential damage to customers' system.

To have the advantages of SATADOM series with Pin7 VCC, and to avoid any potential damage to customers' board designed with VCC power supply, Innodisk suggests that customers MUST design their board with a fuse which should be designed before the SATA socket Pin7 VCC. In other words, customers are suggested NOT TO layout 5V VCC to SATA socket on board directly. A circuit diagram example to explain this is shown as below.

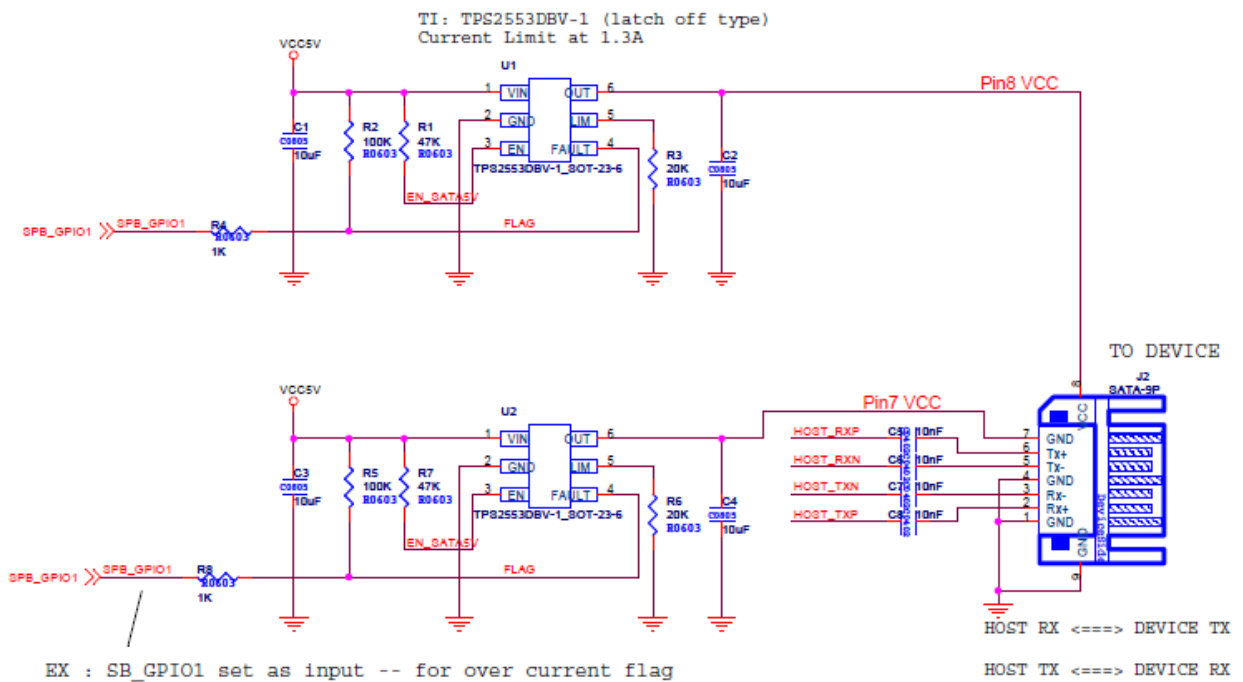

4.6 Power cable

A power cable is shipped with each SATADOM product, which has standard 4pins power connector and special 3 pins power connector for SATADOM. The male and female power connector of SATADOM have foolproof design to avoid misconnection, please check it before power on.

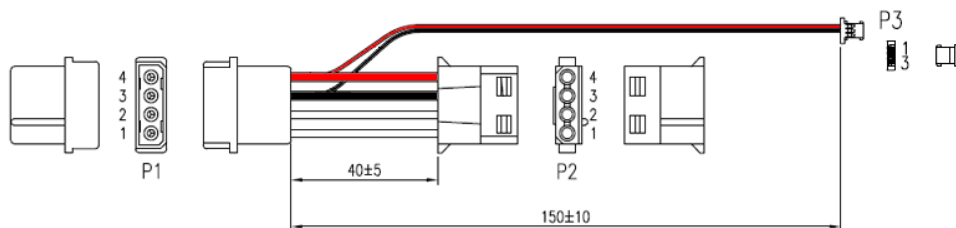

* The item part number end with "B" mean power supply version,

Which doesn't provide power cable.

5. Part Number Rule

CODE	1	2	3	4	5	6	7	8	9	10	11	12	13	14	15	16	17	18	19	20	21	22
	D	E	S	N	H	-	3	2	G	D	0	6	S	C	A	Q	Y	F	-	X	X	X
Description	Disk	ServerDOM				Capacity			Controller			Flash Mode	Operation Temp.	Internal Control	CH.	Flash Type	Pin Type	-	Customized Code			
Definition																						
Code 1st (Disk)											Code 14th (Operation Temperature)											
D : Disk											C: Standard Grade (0°C~ +70°C)											
Code 2nd (Feature set)											W: Industrial Grade (-40°C~ +85°C)											
E : Embedded Series H: ISLC Series											Code 15th (Internal control)											
Code 3rd ~5th (Form factor)											A~Z: PCB version.											
SNH: SATADOM-H (Low profile)											Code 16th (Channel of data transfer)											
Code 7th ~9th (Capacity)											S: Single Channel											
02G: 2GB, 04G: 4GB 08G: 8GB, 16G: 16GB 32G: 32GB, 64G: 64GB											D: Dual Channels											
											Q: Quad Channels											
											Code 17th (Flash Type)											
Code 10th ~12th (Controller)											Y: MLC											
											X: SLC											
											Code 18th (pin7/pin8 type)											
D06: ID106 / ID 167											F: Pin7 version (Optional)											
Code 13th (Flash mode)											A: Pin8 version											
											B: Pin8+Pin7 version											
											Code 19th~21st (Customize code)											
Internal control.																						

Appendix

CE/FCC/RoHS

Certificate

Issue Date: June 15, 2015
Ref. Report No. ISL-15LE240CE

Product Name : ServerDOM-H
Model(s) : ServerDOM-H 3\$*@
(\$: Flash type: (S:SLC,I:iSLC,M:MLC);
*: Product line: (E:Embedded, G: EverGreen, R: InnoRobust);
@: non: Gen1, 2: Gen 2, 3: Gen 3)
Responsible Party : Innodisk Corporation
Address : 5F.No.237, Sec. 1, Datong Rd., Xizhi Dist., New Taipei City 221,
Taiwan (R.O.C.)

We, **International Standards Laboratory**, hereby certify that:

The device bearing the trade name and model specified above has been shown to comply with the applicable technical standards as indicated in the measurement report and was tested in accordance with the measurement procedures specified in European Council Directive- EMC Directive 2004/108/EC. The device was passed the test performed according to :



Standards:

EN 55022: 2010+AC2011 and CISPR 22: 2008 (modified)
EN 61000-3-2: 2006+A1:2009 +A2:2009 and IEC 61000-3-2: 2005+A1:2008 +A2:2009
EN 61000-3-3: 2013 and IEC 61000-3-3: 2013
EN 55024: 2010 and CISPR 24: 2010
EN 61000-4-2: 2009 and IEC 61000-4-2: 2008
EN 61000-4-3: 2006+A1: 2008 +A2: 2010 and
IEC 61000-4-3:2006+A1: 2007+A2: 2010
EN 61000-4-4:2012 and IEC 61000-4-4:2012

I attest to the accuracy of data and all measurements reported herein were performed by me or were made under my supervision and are correct to the best of my knowledge and belief. I assume full responsibility for the completeness of these measurements and vouch for the qualifications of all persons taking them.

International Standards Laboratory

Jim Chu

Jim Chu / Director

Hsi-Chih LAB:

No. 65, Gu Dai Keng Street, Hsi-Chih Dist.,
New Taipei City 221, Taiwan
Tel: 886-2-2646-2550; Fax: 886-2-2646-4641



Lung-Tan LAB:

No. 120, Lane 180, Hsin Ho Rd., Lung-Tan Dist.,
Tao Yuan City 325, Taiwan
Tel: 886-3-407-1718; Fax: 886-3-407-1738



Certificate

Issue Date: June 15, 2015
Ref. Report No. ISL-15LE240FB

Product Name : ServerDOM-H
Model(s) : ServerDOM-H 3\$*
(\$: Flash type: (S:SLC,L:SLC,M:MLC);
*: Product line: (E:Embedded, G: EverGreen, R: InnoRobust);
@: non: Gen1, 2: Gen 2, 3: Gen 3)
Applicant : Innodisk Corporation
Address : 5F.No.237, Sec. 1, Datong Rd., Xizhi Dist., New Taipei City 221,
Taiwan (R.O.C.)

We, **International Standards Laboratory**, hereby certify that:

The device bearing the trade name and model specified above has been shown to comply with the applicable technical standards as indicated in the measurement report and was tested in accordance with the measurement procedures specified. (refer to Test Report if any modifications were made for compliance).



Standards:

FCC CFR Title 47 Part 15 Subpart B: 2012- Section 15.107 and 15.109
ANSI C63.4-2009
Industry Canada Interference-Causing Equipment Standard ICES-003 Issue 5: 2012

Class B

I attest to the accuracy of data and all measurements reported herein were performed by me or were made under my supervision and are correct to the best of my knowledge and belief. I assume full responsibility for the completeness of these measurements and vouch for the qualifications of all persons taking them.

International Standards Laboratory

Jim Chu / Director

Hsi-Chih LAB:
No. 65, Gu Dai Keng Street, Hsi-Chih Dist.,
New Taipei City 221, Taiwan
Tel: 886-2-2646-2550; Fax: 886-2-2646-4641



Lung-Tan LAB:
No. 120, Lane 180, Hsin Ho Rd., Lung-Tan Dist.,
Tao Yuan City 325, Taiwan
Tel: 886-3-407-1718; Fax: 886-3407-1738

