

Approval Sheet

Customer	
Product Number	ACT4GHR72N8J1600S-LVP
Module speed	PC3-12800
Pin	240pin
CI-tRCD-tRP	11-11-11
Date	12 nd September 2014

Approval by Customer

P/N:

Signature:

Date:

Sales: _____ Sr. Technical Manager: John Hsieh

The Total Solution For
Industrial Flash Storage



ACT4GHR72N8J1600S-LVP

4GB DDR3L-1600 Registered ECC Module Specification

Disclaimer:

The style and text of “ACTICA” are registered trademarks of ACTICA Inc. ACTICA products are not designed, intended, or authorized for use in applications intended to support or sustain life, or for any other application for which the failure of the ACTICA product could create a situation in which personal injury or life threatening may occur. Information in this manual is the confidential property in relation to ACTICA’s product, and is subject to change without notice.

Produced by Innodisk Taiwan.

Description

ACTICA ACT4GHR72N8J1600S-LVP is a high speed 4GB DDR3L-1600 Registered ECC. It is designed for mission critical application memory solution. This DIMM includes Error Checking and Correcting (ECC) for maximum reliability. The modules is constructed using 512Mx8 SDRAMs, and is fully compliant with JEDEC specifications. Decoupling capacitors are mounted on the PCB board for better signal integrity. The DIMM feature serial presence detect (SPD) based on a serial EEPROM device using the 2-pin I2C protocol.

Features

- 240-pin Registered Dual Inline Memory Module (RDIMM)
- Memory Module Organization 512Mx72
- Very Low Profile (height: 18.75 mm)
- CL-tRCD-tRP : 11-11-11
- JEDEC standard 1.35V (-0.067V/+0.1V), 1.5V ($\pm 0.075V$)
- VDDQ = 1.35V (-0.067V/+0.1V), 1.5V ($\pm 0.075V$)
- 8 independent internal bank
- Burst Length: 4, 8(Interleave/nibble sequential)
- Bi-directional Differential Data-Strobe
- On Die Termination (ODT)
- Eight-bit prefetch architecture
- Average Refresh Period 7.8us at lower than a T_{CASE} 85°C, 3.9us at 85°C < T_{CASE} < 95 °C
- RoHS Compliant

Address Range

Module Organization	Row address	Column Address	Bank Address	Auto Precharge
512Mx72	A0-A15	A0-A9	BA0-BA2	A10/AP

Pin Description

Pin Name	Description	Pin Name	Description
Ck0	Clock Input, positive line	Par_In	Parity bit for the Address and Control bus
CK0/	Clock Input, negative line	Err_Out	Parity error found on the Address and Control bus
		ODT[0]	On Die Termination Inputs
		DQ[63:0]	Data Input/Output
CKE[1:0]	Clock Enables	CB[7:0]	Data check bits Input/Output
TEST	Memory bus test toll (Not Connected and Not Usable on DIMMs)	DQS[8:0]	Data strobes
RAS/	Row Address Strobe	DQS/[8:0]	Data strobes, negative line
CAS/	Column Address Strobe	DM[8:0]/ DQS[17:9] TDQS[17:9]	Data Masks/ Data strobes, Termination data strobes
WE/	Write Enable	DQS/[17:9] TDQS/[17:9]	Data strobes, negative line, Termination data strobes
S[3:0]	Chip Selects	EVENT/	Reserved for optional hardware temperature sensing
		RESET/	Register and SDRAM control pin
A[9:0],A11, A[15:13]	Address Inputs	VDD	Power Supply
A10/AP	Address Input/Autoprecharge	VSS	Ground
A12/BC	Address Input/Burst chop	VREFDQ	Reference Voltage for DQ
BA[2:0]	SDRAM Bank Addresses	VREFCA	Reference Voltage for CA
SCL	Serial Presence Detect (SPD) Clock Input	VTT	Termination Voltage
SDA	SPD Data Input/Output	VDDSPD	SPD Power
SA[2:0]	SPD Address Inputs	RFU	Reserved for Future Use



4GB DDR3L-1600 VLP RDIMM with ECC

Pin Configuration (Front side/Back side)

Pin	Front	Pin	Back	Pin	Front	Pin	Back	Pin	Front	Pin	Back	Pin	Front	Pin	Back
1	VREFD Q	121	VSS	31	DQ25	151	VSS	60	VDD	180	A3	91	DQ41	211	VSS
2	VSS	122	DQ4	32	VSS	152	DM3,DQS12 ,TDQS12	61	A2	181	A1	92	VSS	212	DM5,DQS14 ,TDQS14
3	DQ0	123	DQ5	33	/DQS3	153	NC,DQS12 ,TDQS12	62	VDD	182	VDD	93	/DQS5	213	NC,DQS14 ,TDQS14
4	DQ1	124	VSS	34	DQS3	154	VSS	63	NC,CK1	183	VDD	94	DQS5	214	VSS
5	VSS	125	DM0,DQS9 ,TDQS9	35	VSS	155	DQ30	64	NC,/CK1	184	CK0	95	VSS	215	DQ46
6	/DQS0	126	NC,DQS9 ,TDQS9	36	DQ26	156	DQ31	65	VDD	185	/CK0	96	DQ42	216	DQ47
7	DQS0	127	VSS	37	DQ27	157	VSS	66	VDD	186	VDD	97	DQ43	217	VSS
8	VSS	128	DQ6	38	VSS	158	CB4,NC	67	VREFCA	187	/EVENT,NC	98	VSS	218	DQ52
9	DQ2	129	DQ7	39	CB0,NC	159	CB5,NC	68	NC/PAR R_IN	188	A0	99	DQ48	219	DQ53
10	DQ3	130	VSS	40	CB0,NC	160	VSS	69	VDD	189	VDD	100	DQ49	220	VSS
11	VSS	131	DQ12	41	VSS	161	DM8,DQS17 ,TDQS17,NC	70	A10/AP	190	BA1	101	VSS	221	DM6,DQS15 ,TDQS15
12	DQ8	132	DQ13	42	/DQS8	162	NC,DQS17 ,TDQS17	71	BA0	191	VDD	102	/DQS6	222	NC,DQS15 ,TDQS15
13	DQ9	133	VSS	43	DQS8	163	VSS	72	VDD	192	/RAS	103	DQS6	223	VSS
14	VSS	134	DM1,DQS10 ,TDQS10	44	VSS	164	CB6,NC	73	/WE	193	/S0	104	VSS	224	DQ54
15	/DQS1	135	NC,DQS10 ,TDQS10	45	CB2,NC	165	CB7,NC	74	/CAS	194	VDD	105	DQ50	225	DQ55
16	DQS1	136	VSS	46	CB3,NC	166	VSS	75	VDD	195	ODT0	106	DQ51	226	VSS
17	VSS	137	DQ14	47	VSS	167	NC(TEST)	76	/S1,NC	196	A13	107	VSS	227	DQ60
18	DQ10	138	DQ15	48	VTT,NC	168	/RESET	77	ODT1,N C	197	VDD	108	DQ56	228	DQ61
19	DQ11	139	VSS	KEY				78	VDD	198	/S3,NC	109	DQ57	229	VSS
20	VSS	140	DQ20	49	VTT,NC	169	CKE1,NC	79	/S2,NC	199	VSS	110	VSS	230	DM7,DQS16 ,TDQS16
21	DQ16	141	DQ21	50	CKE0	170	VDD	80	VSS	200	DQ36	111	/DQS7	231	DM7,DQS16 ,TDQS16
22	DQ17	142	VSS	51	VDD	171	NC	81	DQ32	201	DQ37	112	DQS7	232	VSS
23	VSS	143	DM2,DQS11 ,TDQS11	52	BA2	172	A14	82	DQ33	202	VSS	113	VSS	233	DQ62
24	/DQS2	144	NC,DQS11 ,TDQS11	53	/ERR_O UT/NC	173	VDD	83	VSS	203	DM4,DQS13 ,TDQS13	114	DQ58	234	DQ63
25	DQS2	145	VSS	54	VDD	174	A12 / /BC	84	/DQS4	204	NC,DQS13 ,TDQS13	115	DQ59	235	VSS
26	VSS	146	DQ22	55	A11	175	A9	85	DQS4	205	VSS	116	VSS	236	VDDSPD
27	DQ18	147	DQ23	56	A7	176	VDD	86	VSS	206	DQ38	117	SA0	237	SA1
28	DQ19	148	VSS	57	VDD	177	A8	87	DQ34	207	DQ39	118	SCL	238	SDA
29	VSS	149	DQ28	58	A5	178	A6	88	DQ35	208	VSS	119	SA2	239	VSS
30	DQ24	150	DQ29	59	A4	179	VDD	89	VSS	209	DQ44	120	VTT	240	VTT
								90	DQ40	210	DQ45				

Block Diagram – Part 1

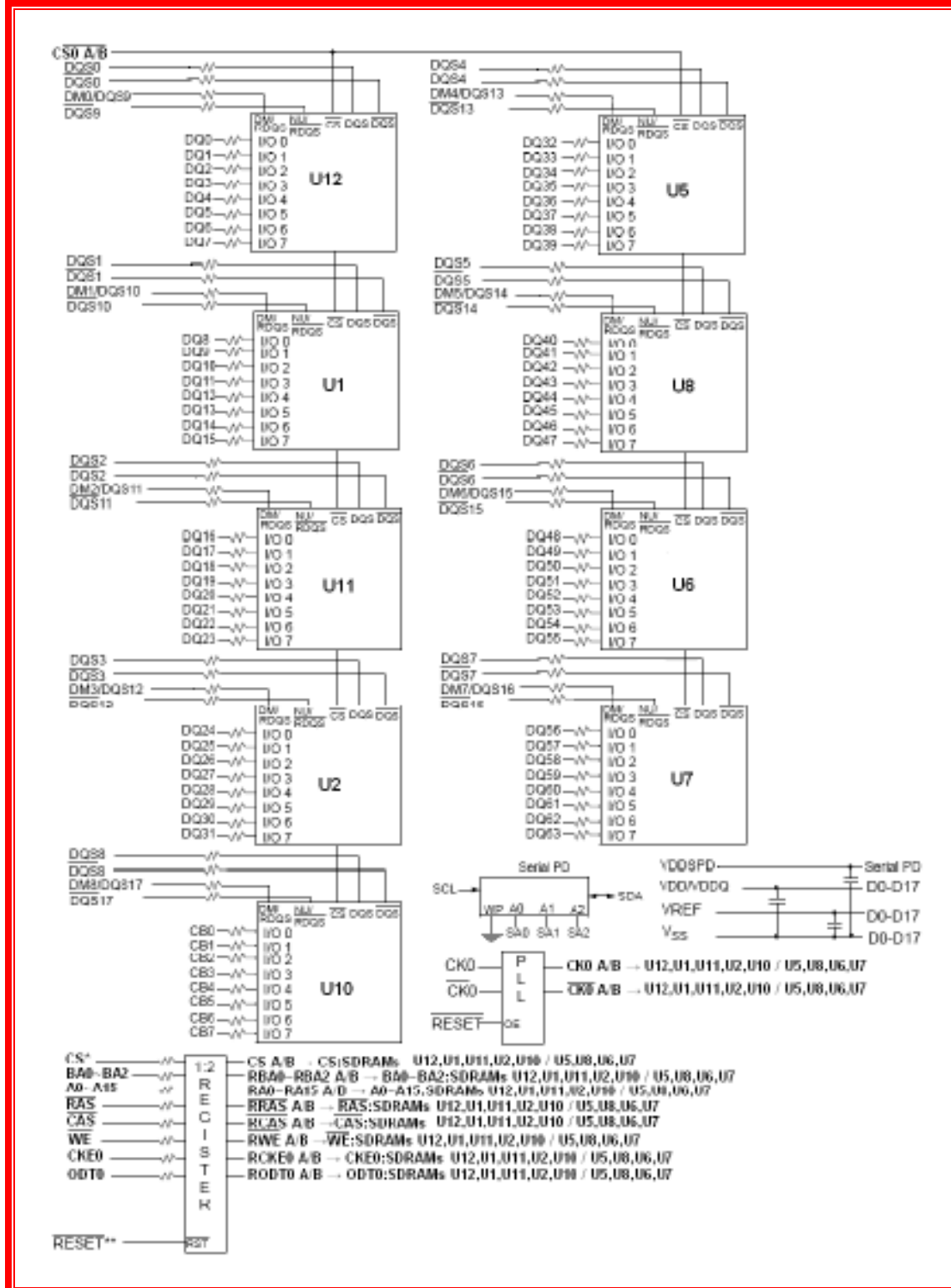

IDD Specification Parameter

(IDD values are for full operating range of Voltage and Temperature)

Symbol	Proposed Conditions	Value	Units
IDD0	Operating one bank active-precharge current; CKE: High; External clock: On; tCK, nRC, nRAS, CL; BL: 8a); AL: 0; CS: High between ACT and PRE; Command, Address, Bank Address Inputs: partially toggling ; Data IO: MID-LEVEL; DM:stable at 0; Bank Activity: Cycling with one bank active at a time: 0,0,1,1,2,2,...; Output Buffer and RTT: Enabled in Mode Registersb); ODT Signal: stable at 0; Pattern Details	252	mA
IDD1	Operating one bank active-read-precharge current; CKE: High; External clock: On; tCK, nRC, nRAS, nRCD, CL; BL: 8a); AL: 0; CS: High between ACT, RD and PRE; Command, Address, Bank Address Inputs, Data IO: partially toggling ; DM:stable at 0; Bank Activity: Cycling with one bank active at a time: 0,0,1,1,2,2,...; Output Buffer and RTT: Enabled in Mode Registersb); ODT Signal: stable at 0;	342	mA
IDD2P0	Precharge power-down current Slow Exit; CKE: Low; External clock: On; AL: 0; CS: stable at 1; Command, Address, Bank Address Inputs: stable at 0; Data IO: MID-LEVEL; DM:stable at 0; Bank Activity: all banks closed; Output Buffer and RTT: Enabled in Mode Registersb); ODT Signal: stable at 0; Precharge Power Down Mode: Slow Exit	72	mA
IDD2P1	Precharge power-down current Fast Exit ; CKE: Low; External clock: On; AL: 0; CS: stable at 1; Command, Address, Bank Address Inputs: stable at 0; Data IO: MID-LEVEL; DM:stable at 0; Bank Activity: all banks closed; Output Buffer and RTT: Enabled in Mode Registersb); ODT Signal: stable at 0; Precharge Power Down Mode: Fast Exit	72	mA
IDD2Q	Precharge quiet standby current; CKE: High; External clock: On; AL: 0; CS: stable at 1; Command, Address, Bank Address Inputs: stable at 0; Data IO: MID-LEVEL; DM:stable at 0; Bank Activity: all banks closed; Output Buffer and RTT: Enabled in Mode Registersb); ODT Signal: stable at 0	90	mA
IDD2N	Precharge standby current; CKE: High; External clock: On; AL: 0; CS: stable at 1; Command, Address, Bank Address Inputs: partially toggling; Data IO: MID-LEVEL; DM:stable at 0; Bank Activity: all banks closed; Output Buffer and RTT: Enabled in Mode Registersb); ODT Signal: stable at 0	99	mA
IDD3P	Active power-down current; CKE: Low; External clock: On; tCK, CL: AL: 0; CS: stable at 1; Command, Address, Bank Address Inputs: stable at 0; Data IO: MID-LEVEL; DM:stable at 0; Bank Activity: all banks open; Output Buffer and RTT: Enabled in Mode Registersb); ODT Signal: stable at 0	90	mA
IDD3N	Active standby current; CKE: High; External clock: On; AL: 0; CS: stable at 1; Command, Address, Bank Address Inputs: partially toggling; Data IO: MID-LEVEL; DM:stable at 0; Bank Activity: all banks open; Output Buffer and RTT: Enabled in Mode Registersb); ODT Signal: stable at 0	189	mA
IDD4W	Operating burst write current; CKE: High; External clock: On; AL: 0; CS: High between WR; Command, Address, Bank Address Inputs: partially toggling; Data IO: seamless write data burst with different data between one burst and the next one; DM: stable at 0; Bank Activity: all banks open, WR commands cycling through banks: 0,0,1,1,2,2,... ; Output Buffer and RTT: Enabled in Mode Registers; ODT Signal: stable at HIGH	603	mA
IDD4R	Operating burst read current; CKE: High; External clock: On; AL: 0; CS: High between RD; Command, Address, Bank Address Inputs: partially toggling; Data IO: seamless read data burst with different data between one burst and the next one; DM:stable at 0; Bank Activity: all banks open, RD commands cycling through banks: 0,0,1,1,2,2,...; Output Buffer and RTT: Enabled in Mode Registers; ODT Signal: stable at 0	612	mA
IDD5B	Burst refresh current; CKE: High; External clock: On; AL: 0; CS: High between REF; Command, Address, Bank Address Inputs: partially toggling ; Data IO: MID-LEVEL; DM:stable at 0; Bank Activity: REF command every nRFC ; Output Buffer and RTT: Enabled in Mode Registersb); ODT Signal: stable at 0	1710	mA
IDD6	Self refresh current; TCASE: 0 - 85°C; Auto Self-Refresh (ASR): Disabledd); Self-Refresh Temperature Range (SRT): Normal); CKE: Low; External clock: Off; CK and CK: LOW; AL: 0; CS, Command, Address, Bank Address, Data IO: MID-LEVEL; DM:stable at 0; Bank Activity: Self-Refresh operation; Output Buffer and RTT: Enabled in Mode Registersb); ODT Signal: MID-LEVEL	108	mA
IDD7	Operating bank interleaved read current; CKE: High; External clock: On; AL: CL-1; CS: High between ACT and RDA; Command, Address, Bank Address Inputs: partially toggling; Data IO: read data bursts with different data between one burst and the next one; DM:stable at 0; Bank Activity: two times interleaved cycling through banks (0, 1, ...7) with different addressing; Output Buffer and RTT: Enabled in Mode Registersb); ODT Signal: stable at 0	1134	mA
IDD8	RESET Low Current RESET : Low; External clock : off; CK and CK : LOW; CKE : FLOATING ; CS, Command, Address, Bank Address, Data IO : FLOATING ; ODT Signal : FLOATING	135	mA

Absolute Maximum DC ratings

Symbol	Parameter	Rating	Units	Notes
V _{DD}	Voltage on V _{DD} pin relative to V _{SS}	-0.4V ~ 1.975V	V	1,3
V _{DDQ}	Voltage on V _{DDQ} pin relative to V _{SS}	-0.4V ~ 1.975V	V	1,3
V _{IN} , V _{OUT}	Voltage on any pin relative to V _{SS}	-0.4V ~ 1.975V	V	1
T _{STG}	Storage Temperature	-55 ~ +100	°C	1, 2
T _{OPER}	Operating Temperature	0 ~ +85	°C	1,2,3

Note:

- 1) Stresses greater than those listed under "Absolute Maximum Ratings" may cause permanent damage to the device. This is a stress rating only and functional operation of the device at these or any other conditions above those indicated in the operational sections of this specification is not implied. Exposure to absolute maximum rating conditions for extended periods may affect reliability.
- 2) Storage Temperature is the case surface temperature on the center/top side of the DRAM. For the measurement conditions, please refer to JEESD51-2 standard.
- 3) V_{DD} and V_{DDQ} must be within 300mV of each other at all times; and V_{REF} must be not greater than 0.6 x V_{DDQ}, When V_{DD} and V_{DDQ} are less than 500mV; V_{REF} may be equal to or less than 300mV.

AC and DC Operating Conditions

Recommended DC Operating Conditions (SSTL - 1.8)

Symbol	Parameter	Rating			Units	Notes
		Min.	Typ.	Max.		
V _{DD}	Supply Voltage	1.283	1.35	1.45	V	1,2
V _{DDQ}	Supply Voltage for Output	1.283	1.35	1.45	V	1,2
V _{DD}	Supply Voltage	1.425	1.5	1.575	V	1,2
V _{DDQ}	Supply Voltage for Output	1.425	1.5	1.575	V	1,2

Note :

- 1) Under all conditions V_{DDQ} must be less than or equal to V_{DD}.
- 2) V_{DDQ} tracks with V_{DD}. AC parameters are measured with V_{DD} and V_{DDQ} tied together.

Input/Output Capacitance

(V_{DD}=1.35V, V_{DDQ}=1.35V, T_A=25°C)

Symbol	Parameter	Max.	Units
C _{CK}	Input capacitance, CK and /CK	1.4	pF
C _I	Input capacitance (All other input only pins)	1.3	
C _{ZQ}	Input/output capacitance of ZQ pin	3	
C _{IO}	Input/output capacitance (DQ, DM, DQS, /DQS, TDQS, /TDQS)	2.3	

Physical Dimension (drawing not in scale) Units : in Millimeters

