

EGPL-G2P3-C1/W1 Daughter Board and Mechanical Drawing

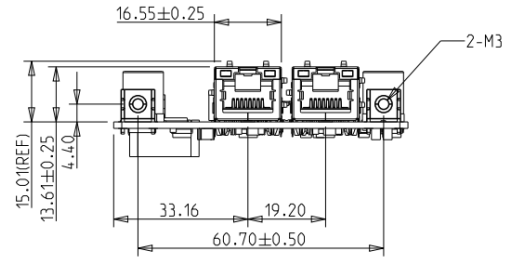

EGPL-G2P3-C2/W2 Daughter Board and Mechanical Drawing

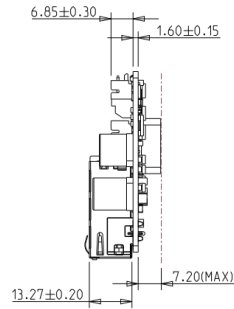
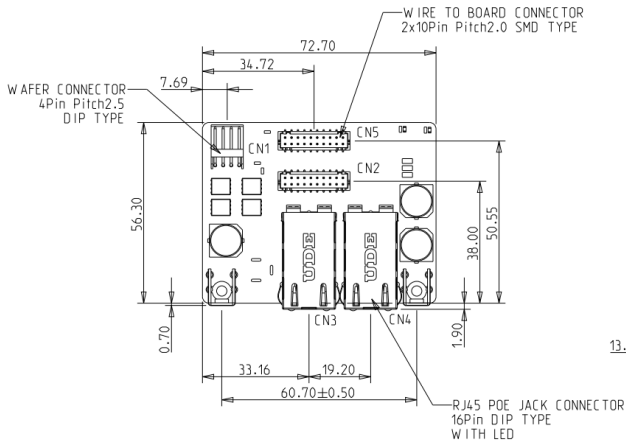
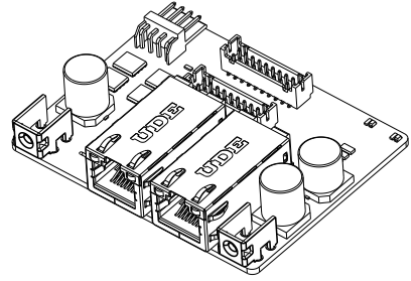
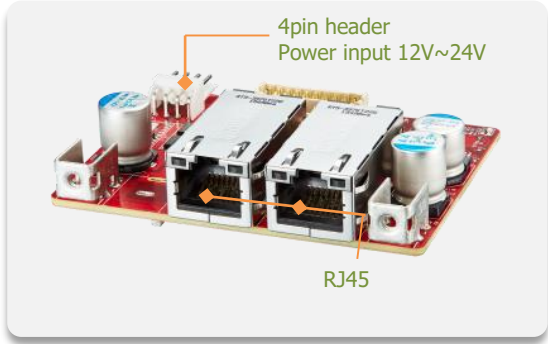
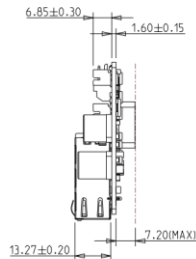
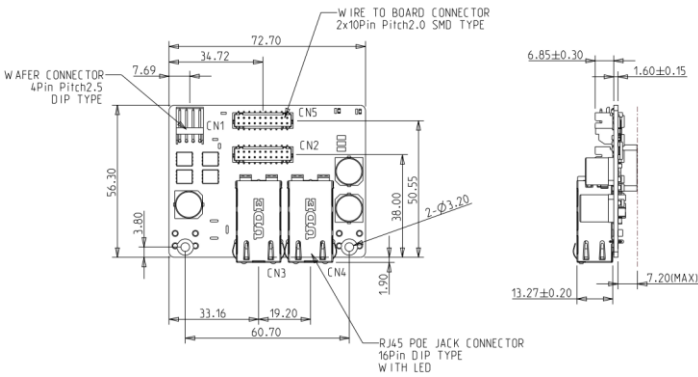
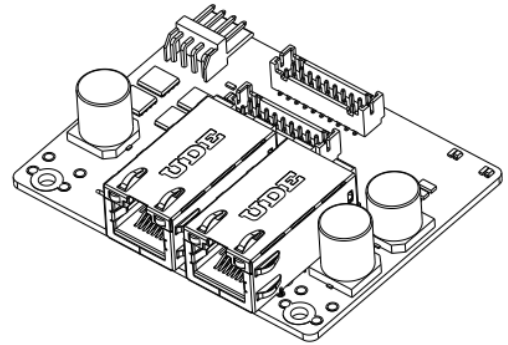
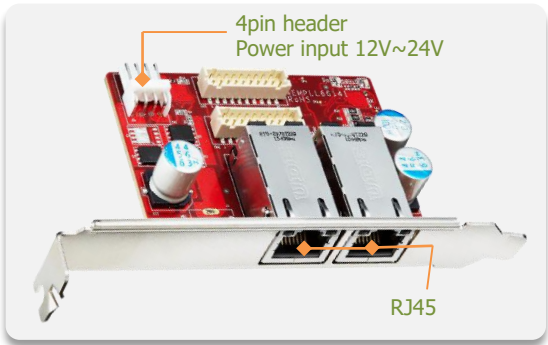

Bracket

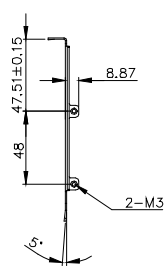
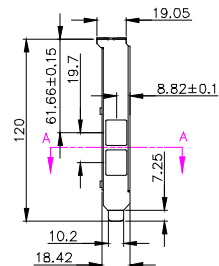
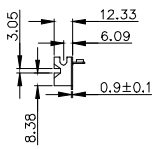
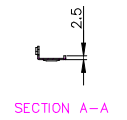
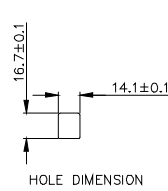

TOLERANCE: ±0.20mm