

EMPL-G1N1

mPCIe to single GbE LAN module

Customer:

Customer

Part Number:

Innodisk

Part Number:

Innodisk

Model Name:

Date:

Innodisk	Customer
Approver	Approver

Table of Contents

TABLE OF CONTENTS	I
REVISION HISTORY	II
LIST OF TABLES	1
LIST OF FIGURES	2
1. PRODUCT INTRODUCTION	3
1.1. OVERVIEW	3
1.2. FEATURES	3
2. PRODUCT SPECIFICATIONS	5
2.1. DEVICE PARAMETERS	5
2.2. ELECTRICAL SPECIFICATIONS.....	5
2.2.1.POWER REQUIREMENT.....	5
2.2.2.POWER CONSUMPTION	5
2.3. ENVIRONMENTAL SPECIFICATIONS	5
2.3.1.TEMPERATURE RANGES.....	5
2.3.2.HUMIDITY	6
2.3.3.SHOCK AND VIBRATION	6
2.3.4.MEAN TIME BETWEEN FAILURE (MTBF)	6
2.4. CE AND FCC COMPATIBILITY.....	6
2.5. ROHS COMPLIANCE	6
2.6. HARDWARE.....	7
2.6.1.LAYOUT	7
2.6.2.PIN DEFINE	8
2.6.3.I/O CONNECTOR MECHANICAL DRAWING & PIN DEFINES	9
2.6.4.EMPL-G1N1 MECHANICAL DRAWING	11
2.6.5.CABLE MECHANICAL DRAWING.....	11
2.6.6.PACKING LIST	12
2.7. SOFTWARE SUPPORT.....	12
3. INSTALLATION GUIDE	12
4. APPEDIX	13
CONTACT US	20

REVISION HISTORY

Revision	Description	Date
1.0	First Released	Oct, 2022

List of Tables

TABLE 1: DEVICE PARAMETERS	5
TABLE 2: POWER REQUIREMENT.....	5
TABLE 3: POWER CONSUMPTION	5
TABLE 4: TEMPERATURE RANGES.....	5
TABLE 5: SHOCK AND VIBRATION	6
TABLE 6: MEAN TIME BETWEEN FAILURE (MTBF).....	6
TABLE 7: MPCIE PCB LAYOUT LEGEND.....	7
TABLE 8: MPCIE PIN DEFINE	8
TABLE 9: WIRE TO BOARD SMD 2*10P CONNECTOR (CN1) PIN DEFINE	9
TABLE 10: 2X5 PIN HEADER (CN2) PIN DEFINE.....	10
TABLE 11: LAN LED TABLE.....	10

List of Figures

FIGURE 1: BLOCK DIAGRAM	3
FIGURE 2: MPCIE BOARD PICTURE.....	4
FIGURE 3: 20PIN PITCH 2.0 CONNECTOR TO 1 RJ45 CABLE.....	4
FIGURE 4: WIRE TO BOARD SMD 2*10P CONNECTOR DRAWING	9
FIGURE 5: EMPL-G1N1 MPCIE BOARD DRAWING	11
FIGURE 6: 20PIN PITCH 2.0 CONNECTOR TO 1 RJ45 CABLE DRAWING.....	11

1. Product Introduction

1.1. Overview

Innodisk EMPL-G1N1 is designed with standard Mini PCI Express form factor, EMPL-G1N1 supports PCIe Gen 2.1 with a single lane to single independent GbE LAN, optimized for higher performance and lower power. EMPL-G1N1 is designed with on-board transformer which brings you a flexible cable design for small form factor or embedded systems.

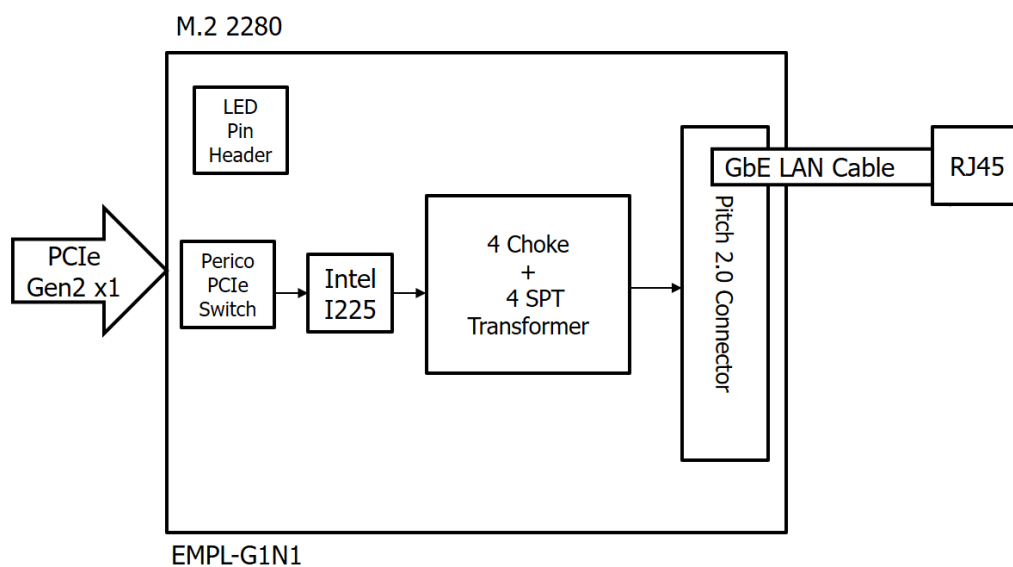

Figure 1: Block Diagram

1.2. Features

- Single GbE LAN ports
- Complies with EN61000-4-2 (ESD) Air-15kV, Contact-8kV
- Transformer on PCB for flexible cable design
- External LED indicator pin for speed 10/100/1000
- Optional Industrial Temperature (-40°C to +85°C) support
- 30μ" golden finger, 3-year warranty
- Industrial design, manufactured in innodisk Taiwan

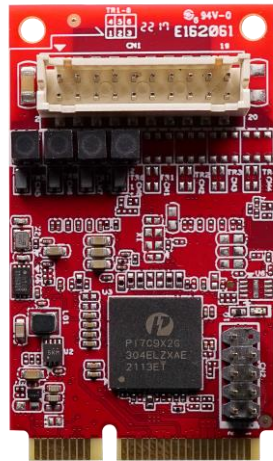

Figure 2: mPCIe Board Picture



Figure 3: 20pin Pitch 2.0 Connector to 1 RJ45 Cable

2. Product Specifications

2.1. Device Parameters

Table 1: Device Parameters

Form Factor	mPCIe
Input I/F	PCI Express 2.1 x 1
Output I/F	GbE LAN x 1
Output Connector	20 Pin Pitch 2.0 Connector
Dimension (WxLxH)	mPCIe Board: 29.85 x 50.8 x 9.35 mm

2.2. Electrical Specifications

2.2.1. Power Requirement

Table 2: Power Requirement

Item	Connector	Rating
Input voltage	mPCIe Golden Finger	+3.3 DC +-5%

2.2.2. Power Consumption

Table 3: Power Consumption

Voltage(V)	RMS(mA)	Max (mA)
3.3	455.62	540.96

2.3. Environmental Specifications

2.3.1. Temperature Ranges

Table 4: Temperature Ranges

Temperature	Range
Operating	Standard Grade: 0°C to +70°C Industrial Grade: -40°C to +85°
Storage	-55°C to +95°

2.3.2. Humidity

Relative Humidity: 10-95%, non-condensing

2.3.3. Shock and Vibration

Table 5: Shock and Vibration

Reliability	Test Conditions	Reference Standards
Vibration	7 Hz to 2K Hz, 20G, 3 axes	IEC 68-2-6
Mechanical Shock	Duration: 0.5ms, 1500 G, 3 axes	IEC 68-2-27

2.3.4. Mean Time between Failure (MTBF)

Reliability prediction methodology provides the basis for reliability evaluation and analysis. The purpose of the prediction is to predict the life time of the product in units of failure rate and MTBF.

Table 6: Mean Time between Failure (MTBF)

Product	Condition	MTBF (Hours)
EMPL-G1N1-C1/W1	The analysis is at 25°C ambient temperature by Telcordia SR-332, Issues 4, Method I, Case 3 under Ground Benign, Controlled environment, 50% operation stress	13,099,305

2.4. CE and FCC Compatibility

EMPL-G1N1 conforms to CE and FCC requirements.

2.5. RoHS Compliance

EMPL-G1N1 is fully compliant with RoHS directive.

2.6. Hardware

2.6.1. Layout

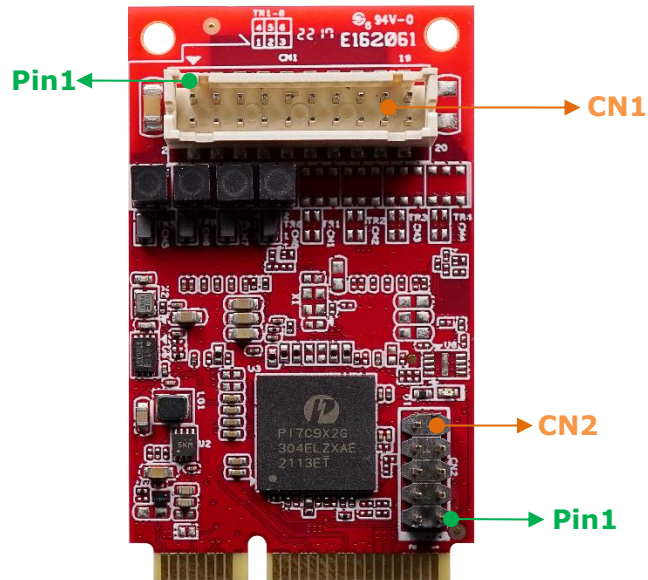

Table 7: mPCIe PCB Layout Legend

Label	Connector Type	Function
CN1	Wire to board SMD 2*10P 180° P:2.0mm H:4.0mm	GbE LAN Signal
CN2	2x5 Pin Header (cut 9pin) P:2.0mm H:3.9mm	10/100/1000 LED Signal

2.6.2. Pin Define

Table 8: mPCIe Pin Define

Signal Name	Pin #	Pin #	Signal Name
NC	51	52	3.3V AUX
NC	49	50	GND
NC	47	48	NC
NC	45	46	NC
GND	43	44	NC
3.3V AUX	41	42	NC
3.3V AUX	39	40	GND
GND	37	38	NC
GND	35	36	NC
RX+	33	34	GND
RX-	31	32	SMBDATA
GND	29	30	SMBCLK
GND	27	28	NC
TX+	25	26	GND
TX-	23	24	3.3V AUX
GND	21	22	PERST#
NC	19	20	NC
NC	17	18	GND
GND	15	16	NC
CLK+	13	14	NC
CLK-	11	12	NC
GND	9	10	NC
GND	7	8	NC
NC	5	6	NC
NC	3	4	GND
PE_WAKE_N	1	2	3.3V AUX

2.6.3. I/O Connector Mechanical Drawing & Pin Defines

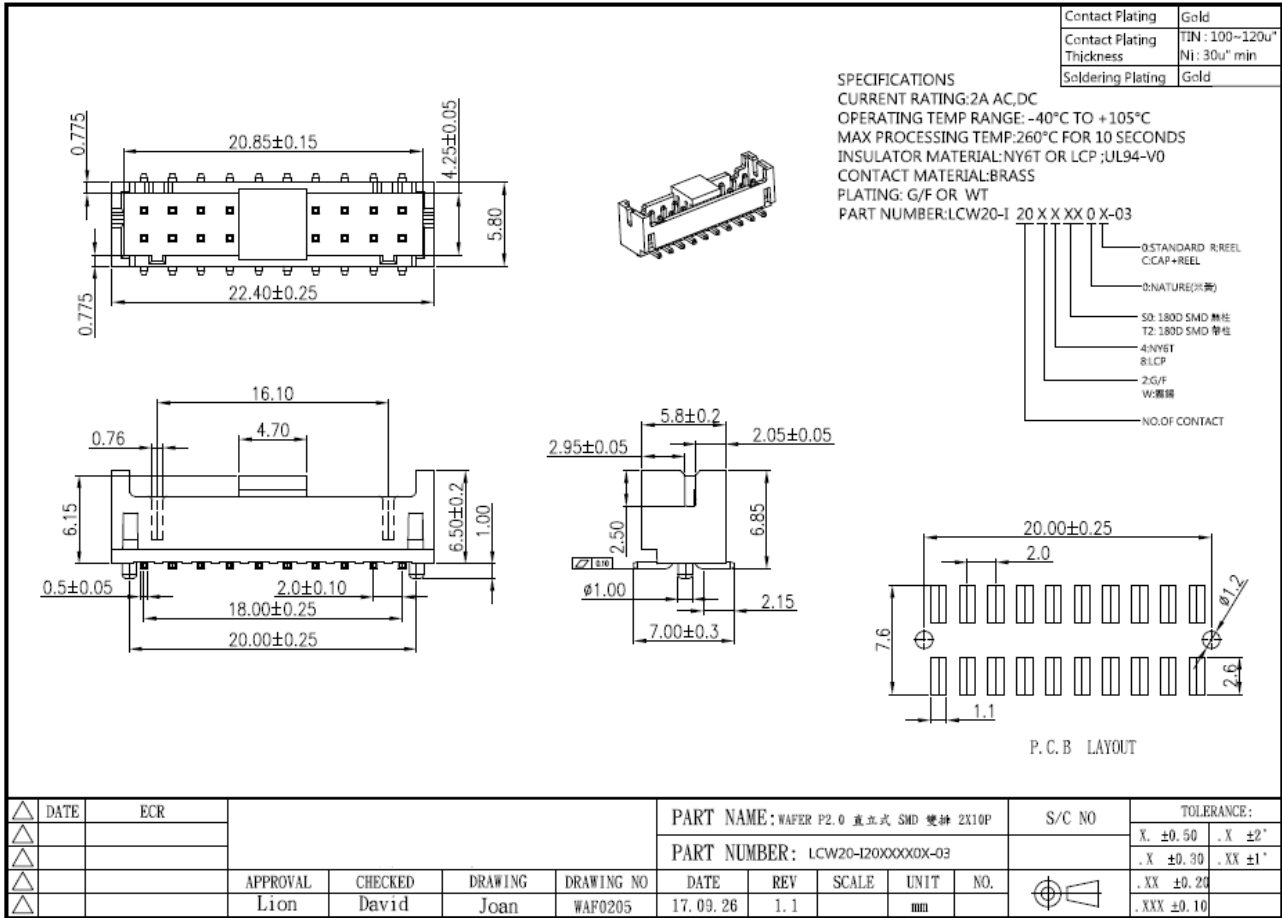

Figure 4: Wire to Board SMD 2*10P Connector Drawing

Table 9: Wire to Board SMD 2*10P Connector (CN1) Pin Define

Signal Name	Pin #	Pin #	Signal Name
NC	2	1	GND
P1_MDI0P_CN	4	3	P1_MDI1P_CN
P1_MDI0N_CN	6	5	P1_MDI1N_CN
P1_MDI2P_CN	8	7	P1_MDI3P_CN
P1_MDI2N_CN	10	9	P1_MDI3N_CN
NC	12	11	NC
NC	14	13	NC
NC	16	15	NC
NC	18	17	NC
NC	20	19	GND

Table 10: 2X5 Pin Header (CN2) Pin Define

Signal Name	Pin #	Pin #	Signal Name
NC	1	2	3.3_LANA
NC	3	4	LANA_LINK_100_N
NC	5	6	LANA_LINK_ACT_N
NC	7	8	LANA_LINK_1000_N
		10	GND

Table 11: LAN LED Table

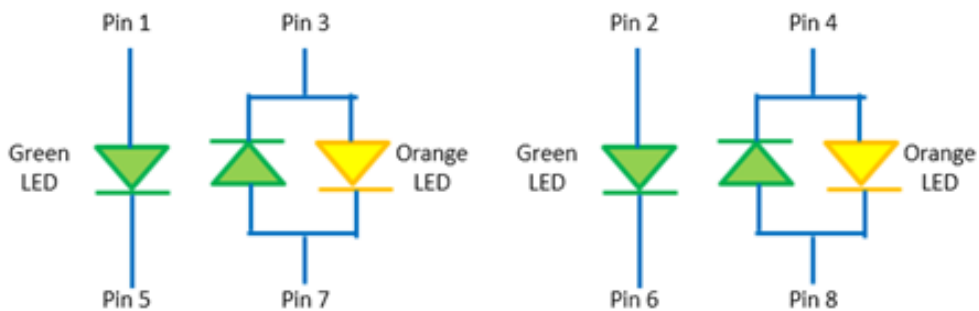

Speed LED	
10M	OFF
100M	OFF
1G	Orange
Link-Activity LED	
Link-up	Green
Tx/Rx Activity	Blinking Green

2.6.4. EMPL-G1N1 Mechanical Drawing

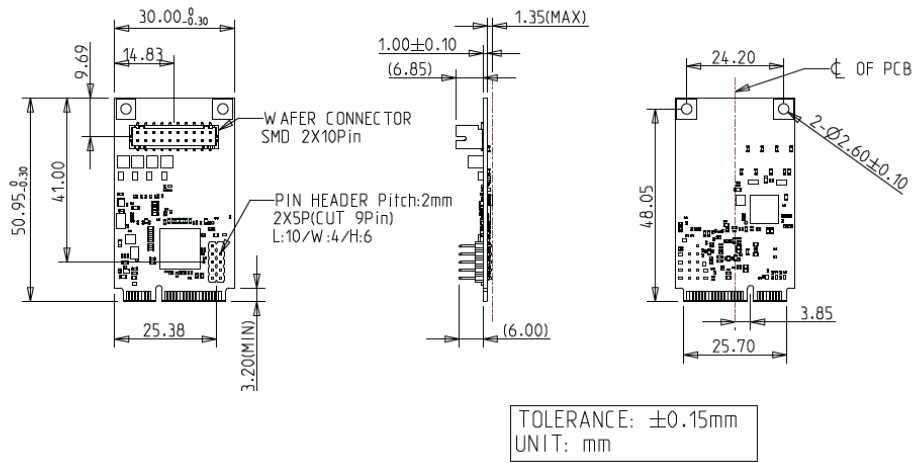

Figure 5: EMPL-G1N1 mPCIe Board Drawing

2.6.5. Cable Mechanical Drawing

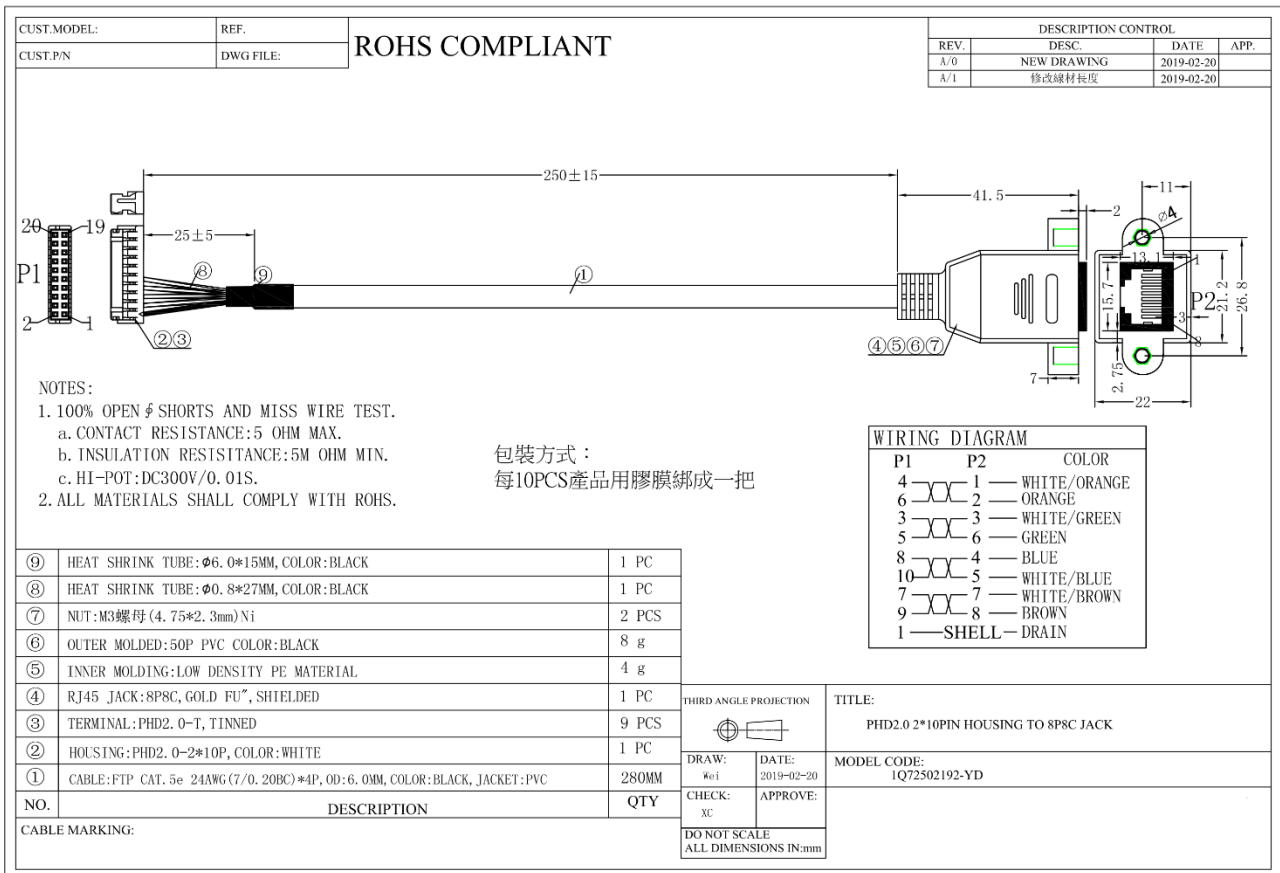

Figure 6: 20pin Pitch 2.0 Connector to 1 RJ45 Cable Drawing

2.6.6. Packing List

- EMPL-G1N1 mPCIe Board x 1
- 20pin Pitch 2.0 Connector to 1 RJ45 Cable x 1

2.7. Software Support

- Windows: 10(64bit)
- Linux (igc): kernel 5.x version

3. Installation Guide

Please download driver from Myinnodisk web site.

<https://myinnodisk.innodisk.com/myinnodisk/Login.aspx>

Or you can download intel i225 chip driver from intel official web site directly.

<https://www.intel.com/content/www/us/en/products/details/ethernet/gigabit-controllers/i225-controllers/downloads.html>

4. Appedix

innodisk

宜鼎國際股份有限公司 Innodisk Corporation REACH Declaration

Tel:(02)7703-3000 Fax:(02) 7703-3555 Internet: <https://www.innodisk.com/>

Innodisk Corporation pursues its social responsibility for global environmental preservation by committing to be compliant with REACH regulation (REGULATION (EC) No 1907/2006). We hereby confirm that the product(s),

Scope: Flash Memory, DRAM Module and Embedded Peripherals Products.

- The standard products of **not listed** in the Appendix2 meet the requirements of REACH SVHC regulations(SVHCs < 0.1% in Article), as described in the candidate list table currently including 224 substances and shown on the ECHA website. (<http://echa.europa.eu/de/candidate-list-table>).
- The standard products listed in the Appendix2 contain(s) one or more hazardous substances or constituents exceeding 0.1 % by weight in article if not otherwise specified in candidate list table.
Where the threshold value is exceeded, the substances in question are to be declared in accompanying. (SVHCs > 0.1% in Article).
- Comply with REACH Annex XVII.

Guarantor

Company name 公司名稱： Innodisk Corporation 宜鼎國際股份有限公司

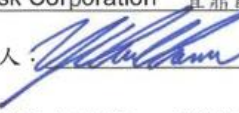
Company Representative 公司代表人：  陳怡全

Company Representative Title 公司代表人職稱： QA Manager 品保經理

Date 日期： 2022 / 06 / 14



RoHS 自我宣告書 (RoHS Declaration of Conformity)

Manufacturer Products: All Innodisk EM FLASH, DRAM and EP products

- 一、 宜鼎國際股份有限公司（以下稱本公司）特此保證售予貴公司之所有產品，皆符合歐盟 2011/65/EU 及 (EU) 2015/863 關於 RoHS 之規範要求。
Innodisk Corporation declares that all products sold to the company, are complied with European Union RoHS Directive (2011/65/EU) and (EU) 2015/863 requirement.
- 二、 本公司同意因本保證書或與本保證書相關事宜有所爭議時，雙方宜友好協商，達成協議。
Innodisk Corporation agrees that both parties shall settle any dispute arising from or in connection with this Declaration of Conformity by friendly negotiations.
- 三、 本公司聲明我們的產品符合 RoHS 指令的附件中 7(a)、7(c)-I、6(c) 允許豁免。
We declare, our products permitted by the following exemptions specified in the Annex of the RoHS directive.
- ※ 7(a) Lead in high melting temperature type solders (i.e. lead-based alloys containing 85% by weight or more lead).
 - ※ 7(c)-I Electrical and electronic components containing lead in a glass or ceramic other than dielectric ceramic in capacitors, e.g. piezoelectric devices, or in a glass or ceramic matrix compound.
 - ※ 6(c) Copper alloy containing up to 4% lead by weight.
(This exemption applies to products that use antennas)

Name of hazardous substance	Limited of RoHS ppm (mg/kg)
鉛 (Pb)	< 1000 ppm
汞 (Hg)	< 1000 ppm
鎘 (Cd)	< 100 ppm
六價鉻 (Cr 6+)	< 1000 ppm
多溴聯苯 (PBBs)	< 1000 ppm
多溴二苯醚 (PBDEs)	< 1000 ppm
鄰苯二甲酸二(2-乙基己基)酯 (DEHP)	< 1000 ppm
鄰苯二甲酸丁酯苯甲酯 (BBP)	< 1000 ppm
鄰苯二甲酸二丁酯 (DBP)	< 1000 ppm

宜鼎國際股份有限公司
Innodisk Corporation

鄰苯二甲酸二異丁酯 (DIBP)	< 1000 ppm
------------------	------------

立 保 證 書 人 (Guarantor)

Company name 公司名稱： Innodisk Corporation 宜鼎國際股份有限公司

Company Representative 公司代表人： Randy Chien 簡川勝

Company Representative Title 公司代表人職稱： Chairman 董事長

Date 日期： 2021 / 06 / 09





CERTIFICATE OF CONFORMITY

Standard: ICES-003:2020 Issue 7, Class B
 ICES-Gen:2018 Issue 1 +A1:2021
 ANSI C63.4-2014 amended as per ANSI C63.4a-2017

Report No.: CIBDBO-WTW-P22070395

Model No.: EMPL-G#N1

#: Output items: (1: 1Port, 2: 2Ports)

Received Date: 2022/7/13

Test Date: 2022/7/18 ~ 2022/7/24

Issued Date: 2022/8/17

Applicant: Innodisk Corporation

Address: 5F., No. 237, Sec. 1, Datong Rd., Xizhi Dist., New Taipei City 221005, Taiwan (R.O.C.)

Issued By: Bureau Veritas Consumer Products Services (H.K.) Ltd., Taoyuan Branch
 Lin Kou Laboratories

Lab Address: No. 47-2, 14th Ling, Chia Pau Vil., Lin Kou Dist., New Taipei City, Taiwan

Test Location: No. 47-2, 14th Ling, Chia Pau Vil., Lin Kou Dist., New Taipei City, Taiwan

Approved by: Jim Hsiang, **Date:** 2022/8/17
 Jim Hsiang / Associate Technical Manager

This test report consists of 25 pages in total. It may be duplicated completely for legal use with the approval of the applicant. It should not be reproduced except in full, without the written approval of our laboratory. The test results in the report only apply to the tested sample. The test results in this report are traceable to the national or international standards.



Prepared by : Ivy Lin / Specialist

This report is governed by, and incorporates by reference, the Conditions of Testing as posted at the date of issuance of this report at <http://www.bureauveritas.com/home/about-us/our-business/cps/about-us/terms-conditions/> and is intended for your exclusive use. Any copying or replication of this report to or for any other person or entity, or use of our name or trademark, is permitted only with our prior written permission. This report sets forth our findings solely with respect to the test samples identified herein. The results set forth in this report are not indicative or representative of the quality or characteristics of the lot from which a test sample was taken or any similar or identical product unless specifically and expressly noted. Our report includes all of the tests requested by you and the results thereof based upon the information that you provided to us. Measurement uncertainty is only provided upon request for accredited tests. Statements of conformity are based on simple acceptance criteria without taking measurement uncertainty into account, unless otherwise requested in writing. You have 60 days from date of issuance of this report to notify us of any material error or omission caused by our negligence or if you require measurement uncertainty; provided, however, that such notice shall be in writing and shall specifically address the issue you wish to raise. A failure to raise such issue within the prescribed time shall constitute your unqualified acceptance of the completeness of this report, the tests conducted and the correctness of the report contents.



CERTIFICATE OF CONFORMITY

Standard: 47 CFR FCC Part 15, Subpart B, Class B
ANSI C63.4:2014

Report No.: FDBDBO-WTW-P22070395

Model No.: EMPL-G#N1

#: Output items: (1: 1Port, 2: 2Ports)

Received Date: 2022/7/13

Test Date: 2022/7/18 ~ 2022/7/24

Issued Date: 2022/8/17

Applicant: Innodisk Corporation

Address: 5F., No. 237, Sec. 1, Datong Rd., Xizhi Dist., New Taipei City 221005, Taiwan (R.O.C.)

Issued By: Bureau Veritas Consumer Products Services (H.K.) Ltd., Taoyuan Branch
Lin Kou Laboratories

Lab Address: No. 47-2, 14th Ling, Chia Pau Vil., Lin Kou Dist., New Taipei City, Taiwan

Test Location: No. 47-2, 14th Ling, Chia Pau Vil., Lin Kou Dist., New Taipei City, Taiwan

FCC Registration /

Designation Number: 418586 / TW1078

Approved by: Jim Hsiang, Date: 2022/8/17
Jim Hsiang / Associate Technical Manager

This test report consists of 25 pages in total. It may be duplicated completely for legal use with the approval of the applicant. It should not be reproduced except in full, without the written approval of our laboratory. The test results in the report only apply to the tested sample. The test results in this report are traceable to the national or international standards.



Prepared by : Ivy Lin / Specialist

This report is governed by, and incorporates by reference, the Conditions of Testing as posted at the date of issuance of this report at <http://www.bureauveritas.com/home/about-us/our-business/cps/about-us/terms-conditions/> and is intended for your exclusive use. Any copying or replication of this report to or for any other person or entity, or use of our name or trademark, is permitted only with our prior written permission. This report sets forth our findings solely with respect to the test samples identified herein. The results set forth in this report are not indicative or representative of the quality or characteristics of the lot from which a test sample was taken or any similar or identical product unless specifically and expressly noted. Our report includes all of the tests requested by you and the results thereof based upon the information that you provided to us. Measurement uncertainty is only provided upon request for accredited tests. Statements of conformity are based on simple acceptance criteria without taking measurement uncertainty into account, unless otherwise requested in writing. You have 60 days from date of issuance of this report to notify us of any material error or omission caused by our negligence or if you require measurement uncertainty; provided, however, that such notice shall be in writing and shall specifically address the issue you wish to raise. A failure to raise such issue within the prescribed time shall constitute your unqualified acceptance of the completeness of this report, the tests conducted and the correctness of the report contents.

CERTIFICATE OF CONFORMITY



Product : mPCIe to dual GbE LAN single board module
Brand : Innodisk
Model No. : EMPL-G#N1
 #: Output items: (1: 1Port, 2: 2Ports)
Applicant : Innodisk Corporation
Report No. : CEBDBO-WTW-P22070395

We, **Bureau Veritas Consumer Products Services (H.K.) Ltd., Taoyuan Branch**, declare that the equipment above has been tested in our facility and found compliance with the requirement limits of applicable standards, in accordance with the Directive 2014/30/EU. The test record, data evaluation and Equipment Under Test (EUT) configurations represented herein are true and accurate under the standards herein specified.

EN 55032:2015 +A11:2020, Class B
EN 61000-3-2:2014 (Not Applicable)
EN IEC 61000-3-2:2019 +A1:2021 (Not Applicable)
EN 61000-3-3:2013 +A2:2021 (Not Applicable)
EN 55035:2017 +A11:2020
 EN 61000-4-2:2009 / IEC 61000-4-2:2008 ED. 2.0
 EN 61000-4-3:2006 +A1:2008 +A2:2010 / IEC 61000-4-3:2010 ED. 3.2
 EN IEC 61000-4-3:2020 / IEC 61000-4-3:2020 ED. 4.0
 EN 61000-4-4:2012 / IEC 61000-4-4:2012 ED. 3.0
 EN 61000-4-5:2014 +A1:2017 / IEC 61000-4-5:2017 ED. 3.1 (Not Applicable)
 EN 61000-4-6:2014+AC:2015 / IEC 61000-4-6:2013 ED. 4.0
 EN 61000-4-8:2010 / IEC 61000-4-8:2009 ED. 2.0
 EN 61000-4-11:2004 +A1: 2017 / IEC 61000-4-11:2017 ED. 2.1 (Not Applicable)
 EN IEC 61000-4-11:2020 / IEC 61000-4-11:2020 ED. 3.0 (Not Applicable)

NOTE: The above EN/IEC basic standards are applied with latest version if customer has no special requirement.

Jim Hsiang

Jim Hsiang / Associate Technical Manager
2022/8/17



No. 47-2, 14th Ling, Chia Pau Vil., Lin Kou Dist., New Taipei City, Taiwan
 Tel: 886-2-26052180 Fax: 886-2-26051924
<http://www.bureauveritas-adt.com> E-Mail: service.adt@tw.bureauveritas.com

CERTIFICATE OF CONFORMITY



Product : mPCIe to dual GbE LAN single board module
Brand : Innodisk
Model No. : EMPL-G#N1
 #: Output items: (1: 1Port, 2: 2Ports)
Applicant : Innodisk Corporation
Report No. : CEBDBO-WTW-P22070395

We, **Bureau Veritas Consumer Products Services (H.K.) Ltd., Taoyuan Branch**, declare that the equipment above has been tested in our facility and found compliance with the requirement limits of applicable standards, in accordance with the Electromagnetic Compatibility Regulations 2016 (S.I. 2016/1091). The test record, data evaluation and Equipment Under Test (EUT) configurations represented herein are true and accurate under the standards herein specified.

BS EN 55032:2015 +A11:2020, Class B

BS EN 61000-3-2:2014 (Not Applicable)

BS EN IEC 61000-3-2:2019+A1:2021 (Not Applicable)

BS EN 61000-3-3:2013+A2:2021 (Not Applicable)

BS EN 55035:2017 +A11:2020

BS EN 61000-4-2:2009 / IEC 61000-4-2:2008 ED. 2.0

BS EN 61000-4-3:2006 +A1:2008 +A2:2010 / IEC 61000-4-3:2010 ED. 3.2

BS EN IEC 61000-4-3:2020 / IEC 61000-4-3:2020 ED. 4.0

BS EN 61000-4-4:2012 / IEC 61000-4-4:2012 ED. 3.0

BS EN 61000-4-5:2014 +A1:2017 / IEC 61000-4-5:2017 ED. 3.1 (Not Applicable)

BS EN 61000-4-6:2014 +AC:2015 / IEC 61000-4-6:2013 ED. 4.0

BS EN 61000-4-8:2010 / IEC 61000-4-8:2009 ED. 2.0

BS EN 61000-4-11:2004 +A1: 2017 / IEC 61000-4-11:2017 ED. 2.1 (Not Applicable)

BS EN IEC 61000-4-11:2020 / IEC 61000-4-11:2020 ED. 3.0 (Not Applicable)

NOTE: The above BS EN/IEC basic standards are applied with latest version if customer has no special requirement.

Jim Hsiang

Jim Hsiang / Associate Technical Manager

2022/8/17



No. 47-2, 14th Ling, Chia Pau Vil., Lin Kou Dist., New Taipei City, Taiwan

Tel: 886-2-26052180 Fax: 886-2-26051924

<http://www.bureauveritas-adt.com> E-Mail: service.adt@tw.bureauveritas.com

Contact us

Headquarters (Taiwan)

5F., No. 237, Sec. 1, Datong Rd., Xizhi Dist., New Taipei City 221, Taiwan

Tel: +886-2-77033000

Email: sales@innodisk.com

Branch Offices:

USA

usasales@innodisk.com

+1-510-770-9421

Europe

eusales@innodisk.com

+31-40-3045-400

Japan

jpsales@innodisk.com

+81-3-6667-0161

China

sales_cn@innodisk.com

+86-755-2167-3689

www.innodisk.com

© 2022 Innodisk Corporation.

All right reserved. Specifications are subject to change without prior notice.

October 18, 2022