

R15IM3S-67C3-P(HB)

15" ARM A53 G-WIN Full IP67 P-CAP Panel PC



KEY FEATURES

- ARM A53 Quad Core 2.0GHz
- High Quality 15" Panel, 1024 x 768 resolution, 1000 nits
- P-cap multi touch screen Optical Bonding with Panel to increase the clarity and transparency
- Optional True Flat 5 Wire Resistive Touch Optical Bonding with Panel
- Optional Anti-Reflective Protection Glass Optical Bonding with Panel
- Dust/ Water proof design with VESA mount Full IP67 Panel PC
- Aluminum Die-Casting Housing with Anti-Corrosion Treatments
- Build in ambient light sensor
- 10 to 55°C wide operating temperature
- Wide Range 9 to 36V DC Input with isolation. Optional for Ignition On/Off delay

INTRODUCTION

Winmate G-WIN IP67 Panel PC Series is designed to excel in demanding environments, offering a versatile range of display sizes from 7" to 21.5" and supporting both Windows and Android operating systems. Engineered for durability and performance, these Panel PCs feature advanced PCAP touch technology, optical bonding for enhanced visibility, and rugged aluminum housing. With a full IP67 rating for complete protection against water and dust, they are ideal for industrial and outdoor applications. The series also supports VESA mount solutions for flexible installation and offers optional high-brightness displays for optimal readability in bright conditions.

SPECIFICATIONS

System Specification

Processor	ARM A53 (Quad Core 2.0GHz)	Memory	4GB LPDDR4
Storage	eMMC: Onboard 32 GB	Operating System	Android 11 (Upgradeable to Android 13) Linux Yocto 5.10.104 with QT 5.15 (Optional) Linux Ubuntu Server 22.04 (Optional)
WLAN	Support (Optional)	BT	Support (Optional)

Display

Resolution	1024x768	Size	15.0 inches
Contrast Ratio	2000:1	Panel Brightness	1000.0 nits
View Angles	88,88,88,88	Active Area	304.1x228.1 mm

Mechanical

Dimension	379.4 x 278.4 x 58 mm	Weight	3.8 kg
Mounting	VESA mount	Enclosure	Aluminum Housing

Cooling System Fanless Design

Environment

Operating Humidity	10% to 90% RH, Non-Condensing	Operating Temperature	-10°C to 55°C -40°C to 70°C (with intelligent heater)
Storage Temperature	-30°C to 70°C	Shock	MIL-STD-810G Method 516.6 Procedure I
Vibration	MIL-STD-810G Method 514.6 Procedure I	IP rating	IP67

Certification

Certification CE, FCC

IO Ports

Power Input	1 x M12 waterproof connector for 9~36V DC	USB Port	1 x M12 waterproof connector for 2 x USB2.0
Serial Port	1 x M12 waterproof connector for RS232	LAN	1 x waterproof Giga LAN RJ45 connector
Indicator	1 x LED Indicator for power 1 x LED Indicator for storage		

Control

Button

- 1 x "Power" key to power on the device.
- 1 x "+" key to increase screen brightness.
- 1 x "-" key to decrease screen brightness.
- 1 x "Menu" key can Automatically or manually adjusts brightness of the display screen
- 1 x Day / Night Mode button
- 1 x LED indicator brightness adjustment button
- 1 x Ambient Light sensor

Accessory

Accessory	External open wire Power cable with waterproof connector External USB cable with waterproof connector External COM cable with waterproof connector External LAN cable with waterproof connector Waterproof caps RJ45 female-female converter VESA screws	Optional Accessory	100~240V AC to DC 120W Adapter with power cord (Optional)
------------------	--	---------------------------	---

DIMENSIONS UNIT:MM

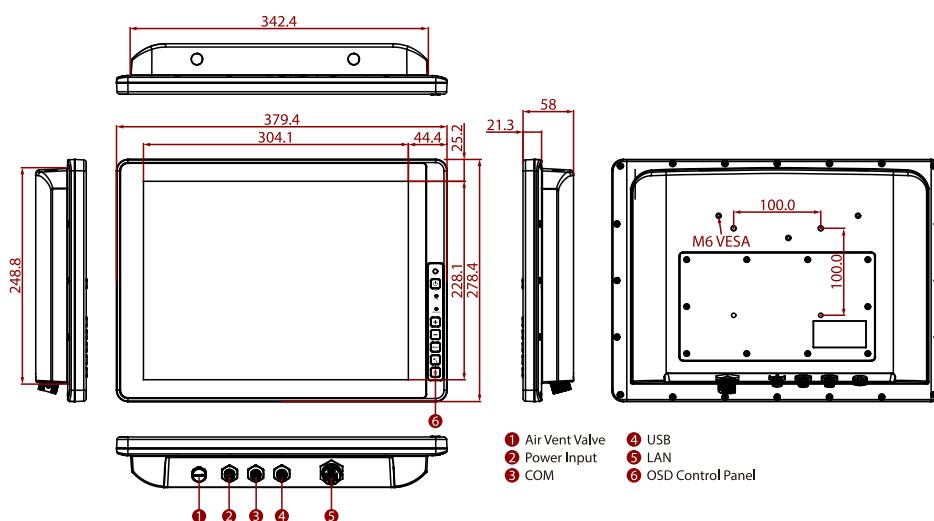

NOTE

1. This is a simplified drawing and some components are not marked in detail.
2. Weight of the device varies by configuration.
3. Please contact our sales representative if you need further product information.
4. All specifications are subject to change without prior notice.
5. The product shown in this datasheet is a standard model. For diagrams that contain customized or optional I/O, please contact the Winmate Sales Team for more information.