

M700DQ9

7 inch Qualcomm® QCS6490, Sunlight Readable Android Tablet



KEY FEATURES

- 7 inch android tablet, 1280 x 720 TFT Panel with direct optical bonding
- Supports Android 13.0 OS, Sunlight readable android tablet
- IP65 waterproof and dustproof

INTRODUCTION

Winmate M700 Series Rugged Tablet is a compact and durable solution designed for demanding environments. Featuring a 7-inch sunlight-readable display with direct optical bonding, it ensures clear visibility under any lighting conditions. Powered by advanced processors and supporting Android OS, the M700 Series delivers reliable performance for fieldwork and industrial applications. With IP65-rated protection, extreme temperature tolerance, and lightweight design, it is ideal for logistics, data collection, and outdoor operations.

SPECIFICATIONS

Display

Resolution	1280x720	Size	7.0 inches
Contrast Ratio	800:1	Panel Brightness	650 nits
View Angles	80,80,80,80	Type	Projected Capacitive Multi Touch
Touch Mode	Support Hand / Gloves and Rain Mode	Bonding	Optical Bonding for Sunlight Viewability

System Specification

Processor	Qualcomm® QCS6490, Octa-Core, up to 2.7GHz	Memory	8GB
Storage	128GB	Operating System	Android 13.0
WLAN	Support	BT	Support
WWAN	4G/5G (Optional)	GNSS	GPS/GLONASS
RFID	NFC (Read / Write, Peer to Peer mode) (Optional)	Sensors	Ambient Light Sensor, E-Compass, Gyro, Acceleration Sensors

Camera

Front Camera	8MP Camera	Rear Camera	16MP Camera with LED Auxiliary Light (Auto Focus)
---------------------	------------	--------------------	---

Mechanical

Dimension	212.4 x 132.8 x 19 mm	Weight	550g
------------------	-----------------------	---------------	------

IO Ports

USB Port	1 x USB 3.0 Type C OTG	SD Card Slot	1 x Micro SD Card Slot
SIM Card Slot	1 x Micro SIM Card Slot 1 x eSIM	Audio	1 x Audio Combo connector (Mic in and Line Out) 2 x Built-in Mic 1 x Speaker 1 x Earphone

Indicator	2 x LED Indicators (Power, Battery)	Docking Connector	1 x Docking Connector
------------------	-------------------------------------	--------------------------	-----------------------

Environment

Operating Humidity	5% to 95% RH, Non-Condensing	Operating Temperature	-10°C to 50°C (Battery mode) -20°C to 60°C (Charging mode) Please avoid charging in hazardous locations.
Storage Temperature	-30°C to 70°C	Shock	MIL-STD-810H Method 516.8 Procedure I
Vibration	MIL-STD-810H Method 514.8 Procedure I	IP rating	IP65
Drop	MIL-STD-810H Method 516.8, 5 ft		

Certification

Certification	CE, FCC, AT&T, FirstNet, RCM
----------------------	------------------------------

Control

Button	1 x Volume + , 1 x Volume - , 1 x Power Button, 1 x Home Button, 1 x Menu Button, 1 x Return Button, 1 x Trigger Button
---------------	---

Power

Battery	3.7V 5300mAh	Battery Operating Time	20Hr
Power Rating	DC 5V	Adapter	Input: 100V-240V AC Output: DC 5V 3A

Security Function

SOTI MobiControl	SOTI MobiControl Compliance
-------------------------	-----------------------------

Accessory

Accessory	Universal Adapter x1 Battery x1 USB Type-C Cable x1	Optional Accessory	Battery Charging Dock Vehicle Dock (Charging + Connectors) Vehicle Dock (Charging Only) Desk Dock Hand Strap Micro SD Card Capacitive Touch Stylus Vehicle Adapter USB-C to HDMI Adapter
------------------	---	---------------------------	--

Barcode Scanner

Barcode Scanner	1D/2D Barcode Reader (Optional)
------------------------	---------------------------------

DIMENSIONS UNIT:MM

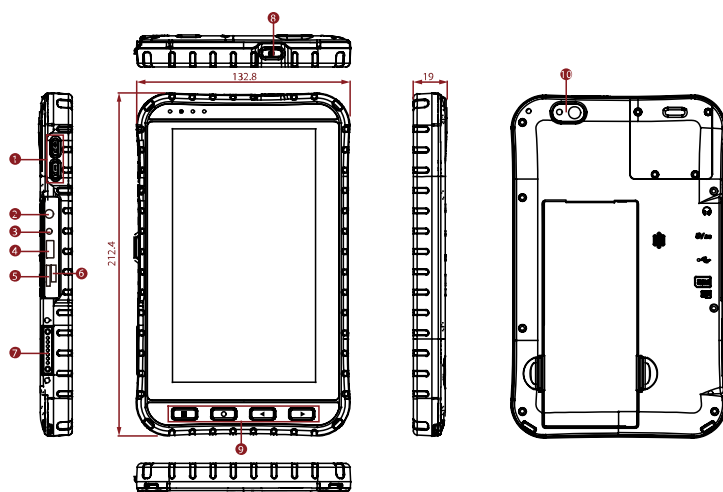

- ① Function Button
- ② Audio
- ③ Power Input
- ④ USB Type-C
- ⑤ Micro SD Card Slot
- ⑥ SIM Card Slot
- ⑦ Docking Connector
- ⑧ Power Switch
- ⑨ Function Button
- ⑩ Camera

NOTE

1. This is a simplified drawing and some components are not marked in detail.
2. Please contact our sales representative if you need further product information.
3. All specifications are subject to change without prior notice.
4. The product shown in this datasheet is a standard model. For diagrams that contain customized or optional I/O, please contact the Winmate Sales Team for more information.