

# EMPV-1201

**mPCIe to Dual VGA &HDMI (or DVI) Module**

**Customer:**

---

**Customer**

**Part Number:**

---

**Innodisk**

**Part Number:**

---

**Innodisk**

**Model Name:**

---

**Date:**

---

<b>Innodisk</b>	<b>Customer</b>
<b>Approver</b>	<b>Approver</b>

## Table of Contents

<b>TABLE OF CONTENTS</b> .....	<b>I</b>
<b>REVISION HISTORY</b> .....	<b>II</b>
<b>LIST OF TABLES</b> .....	<b>1</b>
<b>LIST OF FIGURES</b> .....	<b>2</b>
<b>1. PRODUCT INTRODUCTION</b> .....	<b>3</b>
1.1. OVERVIEW .....	3
1.2. FEATURES .....	3
<b>2. PRODUCT SPECIFICATIONS</b> .....	<b>4</b>
2.1. DEVICE PARAMETERS .....	4
2.2. ELECTRICAL SPECIFICATIONS .....	5
2.2.1. POWER REQUIREMENT .....	5
2.2.2. POWER CONSUMPTION .....	5
2.3. ENVIRONMENTAL SPECIFICATIONS .....	5
2.3.1. TEMPERATURE RANGES .....	5
2.3.2. HUMIDITY .....	5
2.3.3. SHOCK AND VIBRATION .....	5
2.3.4. MEAN TIME BETWEEN FAILURE (MTBF) .....	6
2.4. CE AND FCC COMPATIBILITY .....	6
2.5. ROHS COMPLIANCE .....	6
2.6. HARDWARE .....	6
2.6.1. LAYOUT .....	6
2.6.2. PIN DEFINE .....	7
2.6.3. I/O CONNECTOR MECHANICAL DRAWING & PIN DEFINES .....	9
2.6.4. EMPV-1201 MECHANICAL DRAWING .....	12
2.6.5. CABLE MECHANICAL DRAWING & PIN DEFINES .....	13
2.6.6. PACKING LIST .....	14
2.7. SOFTWARE SUPPORT .....	14
<b>3. INSTALLATION GUIDE</b> .....	<b>14</b>
<b>4. APPEDIX</b> .....	<b>15</b>
<b>CONTACT US</b> .....	<b>19</b>

## REVISION HISTORY

Revision	Description	Date
1.0	First Released	Sep, 2020
1.1	Remove DVI cable drawing	Oct, 2025

**List of Tables**

**TABLE 1: DEVICE PARAMETERS ..... 4**

**TABLE 2: POWER REQUIREMENT..... 5**

**TABLE 3: POWER CONSUMPTION ..... 5**

**TABLE 4: SHOCK AND VIBRATION ..... 5**

**TABLE 5: MEAN TIME BETWEEN FAILURE (MTBF)..... 6**

**TABLE 6: PCB LAYOUT LEGEND..... 6**

**TABLE 7: MPCIE PIN DEFINE ..... 7**

**TABLE 8: WIRE TO BOARD SMD 2\*20P CONNECTOR PIN DEFINE (CN1) ..... 10**

**TABLE 9: WIRE TO BOARD SMD 2\*20P CONNECTOR PIN DEFINE (CN2) ..... 11**

## List of Figures

<b>FIGURE 1: BLOCK DIAGRAM .....</b>	<b>3</b>
<b>FIGURE 2: EMPV-1201 BOARD PICTURE .....</b>	<b>4</b>
<b>FIGURE 3: WIRE TO BOARD SMD 2*10P CONNECTOR DRAWING (CN1/CN2) .....</b>	<b>9</b>
<b>FIGURE 4: EMPV-1201 DRAWING .....</b>	<b>12</b>
<b>FIGURE 5: VGA CABLE DRAWING .....</b>	<b>13</b>
<b>FIGURE 6: HDMI CABLE DRAWING .....</b>	<b>13</b>

# 1. Product Introduction

## 1.1. Overview

Innodisk EMPV-1201 is designed with mPCIe form factor, which supports PCIe Gen 1.0 with dual VGA and HDMI or DVI, optimized for higher performance and lower power, which brings you a flexible expansion solution for embedded systems.

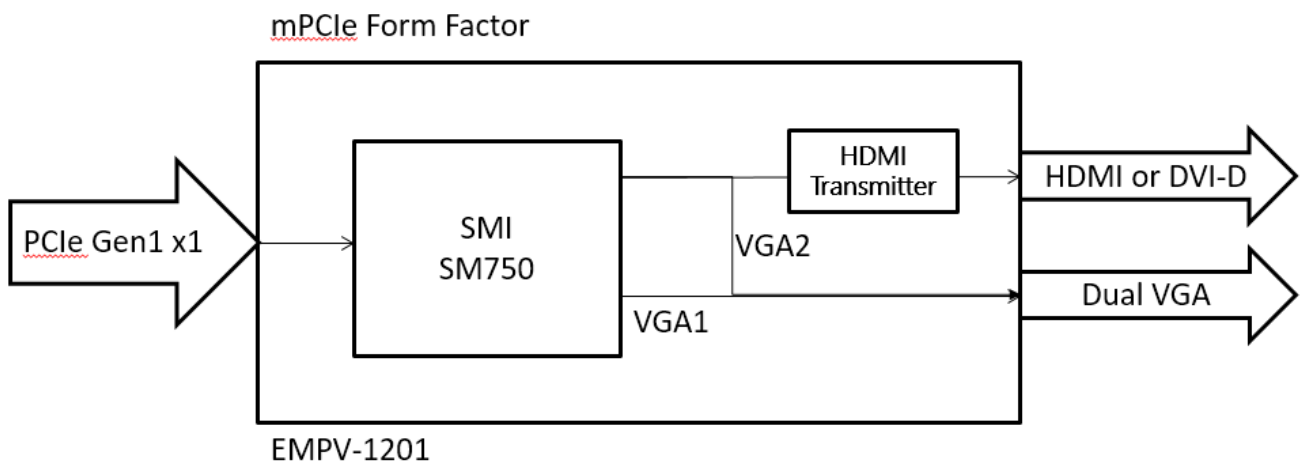

**Figure 1: Block Diagram**

## 1.2. Features

- VGA Output up to 1920x1440. up to 75Hz vertical rate.
- HDMI up to 1080P, Ultra low power consumption.
- Allow for 90°, 180°, and 270° rotation of onscreen images.
- DVI-D Single Link up to 1080P.
- 30μ" golden finger, 3 years warranty.

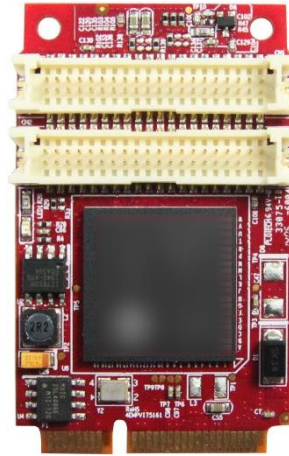



Figure 2: EMPV-1201 Board Picture

## 2. Product Specifications

### 2.1. Device Parameters

Table 1: Device Parameters

<b>Form Factor</b>	mPCIe
<b>Input I/F</b>	PCI Express 1.0 x 1
<b>Output I/F</b>	VGA x 2, HDMI or DVI-D x 1 *VGA2 shares the same signal with HDMI/DVI-D. 
<b>Output Connector</b>	40pin 1.25mm x 2(40DP-1.25)
<b>Dimension (WxLxH)</b>	50.95 x 31.5 x 7 mm

## 2.2. Electrical Specifications

### 2.2.1. Power Requirement

**Table 2: Power Requirement**

Item	Connector	Rating
Input voltage	mPCIe	+3.3 VDC +-5%

### 2.2.2. Power Consumption

**Table 3: Power Consumption**

Full Load (mA)	Voltage (V)
600	3.3

## 2.3. Environmental Specifications

### 2.3.1. Temperature Ranges

**Table 4: Temperature Ranges**

Temperature	Range
Operating	0°C ~ +70°C
Storage	-55°C to +95°

### 2.3.2. Humidity

Relative Humidity: 10-95%, non-condensing

### 2.3.3. Shock and Vibration

**Table 4: Shock and Vibration**

Reliability	Test Conditions	Reference Standards
Vibration	7 Hz to 2K Hz, 20G, 3 axes	IEC 68-2-6
Mechanical Shock	Duration: 0.5ms, 1500 G, 3 axes	IEC 68-2-27



**2.3.4. Mean Time between Failure (MTBF)**

Reliability prediction methodology provides the basis for reliability evaluation and analysis. The purpose of the prediction is to predict the life time of the product in units of failure rate and MTBF.

**Table 5: Mean Time between Failure (MTBF)**

Product	Condition	MTBF (Hours)
EMPV-1201	The analysis is at 25°C ambient temperature by Telcordia SR-332, Issues 4, Method I, Case 3 under Ground Benign, Controlled environment, 50% operation stress	10,731,991

**2.4. CE and FCC Compatibility**

EMPV-1201 conforms to CE and FCC requirements.

**2.5. RoHS Compliance**

EMPV-1201 is fully compliant with RoHS directive.

**2.6. Hardware**

**2.6.1. Layout**

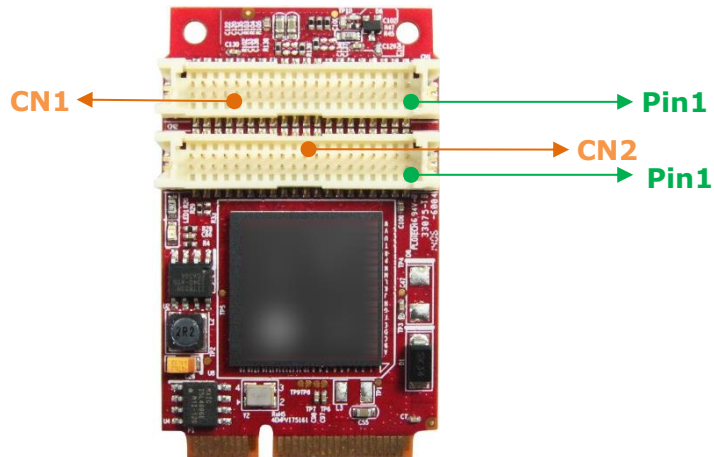

**Table 6: PCB Layout Legend**

Label	Connector Type	Function
<b>CN1</b>	Wire to board SMD 2*20P 180° P:1.25mm H:4.8mm	VGA x 2
<b>CN2</b>	Wire to board SMD 2*20P 180° P:1.25mm H:4.8mm	HDMI or DVI

## 2.6.2. Pin Define

**Table 7: mPCIe Pin Define**

Signal Name	Pin #	Pin #	Signal Name
NC	<b>51</b>	<b>52</b>	3.3V AUX
NC	<b>49</b>	<b>50</b>	GND
NC	<b>47</b>	<b>48</b>	NC
NC	<b>45</b>	<b>46</b>	NC
GND	<b>43</b>	<b>44</b>	NC
3.3V	<b>41</b>	<b>42</b>	NC
3.3V	<b>39</b>	<b>40</b>	GND
GND	<b>37</b>	<b>38</b>	NC
GND	<b>35</b>	<b>36</b>	NC
PCIe_RX+	<b>33</b>	<b>34</b>	GND
PCIe_RX-	<b>31</b>	<b>32</b>	NC
GND	<b>29</b>	<b>30</b>	NC
GND	<b>27</b>	<b>28</b>	NC
PCIe_TX+	<b>25</b>	<b>26</b>	GND
PCIe_TX-	<b>23</b>	<b>24</b>	3.3V
GND	<b>21</b>	<b>22</b>	PERST#
NC	<b>19</b>	<b>20</b>	NC
NC	<b>17</b>	<b>18</b>	GND
GND	<b>15</b>	<b>16</b>	NC
PCIe_CLK+	<b>13</b>	<b>14</b>	NC
PCIe_CLK-	<b>11</b>	<b>12</b>	NC

GND	<b>9</b>	<b>10</b>	NC
GND	<b>7</b>	<b>8</b>	NC
NC	<b>5</b>	<b>6</b>	NC
NC	<b>3</b>	<b>4</b>	GND
NC	<b>1</b>	<b>2</b>	3.3V

2.6.3. I/O Connector Mechanical Drawing & Pin Defines

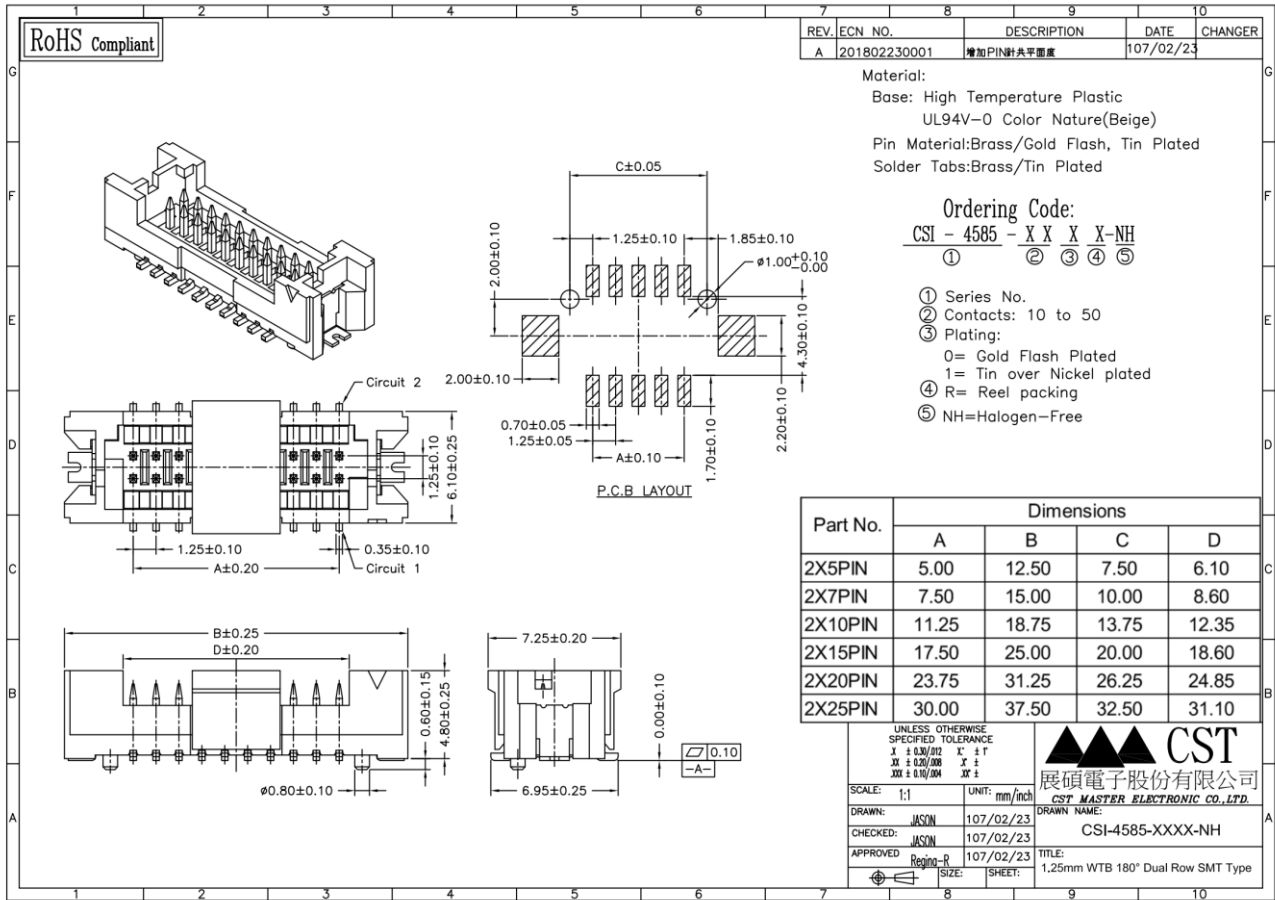

Figure 3: Wire to Board SMD 2\*10P Connector Drawing (CN1/CN2)

**Table 8: Wire to Board SMD 2\*20P Connector Pin Define (CN1)**

Signal Name	Pin #	Pin #	Signal Name
+5V	2	1	3.3V
+5V	4	3	3.3V
	6	5	
GND	8	7	GND
R_1	10	9	B_1
G_1	12	11	
GND	14	13	GND
H_Sync_1	16	15	DDC_SCL_1
V_Sync_1	18	17	DDC_SDA_1
GND	20	19	GND
R_0	22	21	B_0
G_0	24	23	
GND	26	25	GND
H_Sync_0	28	27	DDC_SCL_0
V_Sync_0	30	29	DDC_SDA_0
GND	32	31	GND
	34	33	
	36	35	
GND	38	37	GND
	40	39	

**Table 9: Wire to Board SMD 2\*20P Connector Pin Define (CN2)**

Signal Name	Pin #	Pin #	Signal Name
+5V	2	1	+3.3V
+5V	4	3	+3.3V
	6	5	
GND	8	7	GND
TMDS_D0+	10	9	TMDS_D1+
TMDS_D0-	12	11	TMDS_D1-
GND	14	13	GND
TMDS_D2+	16	15	
TMDS_D2-	18	17	
GND	20	19	GND
	22	21	
	24	23	
GND	26	25	GND
	28	27	DDC_SCL
	30	29	DDC_SDA
GND	32	31	GND
TMDS_CK+	34	33	CEC
TMDS_CK-	36	35	HPD
GND	38	37	GND
	40	39	

**2.6.4. EMPV-1201 Mechanical Drawing**

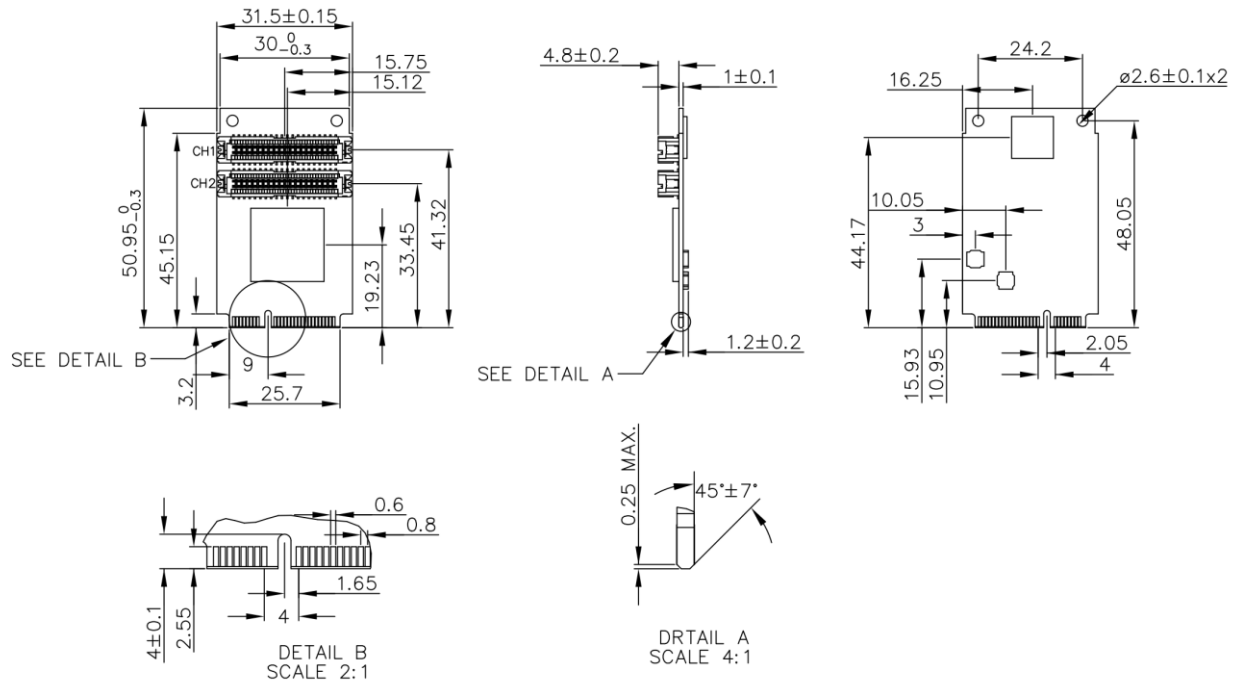

**Figure 4: EMPV-1201 Drawing**

2.6.5. Cable Mechanical Drawing & Pin defines

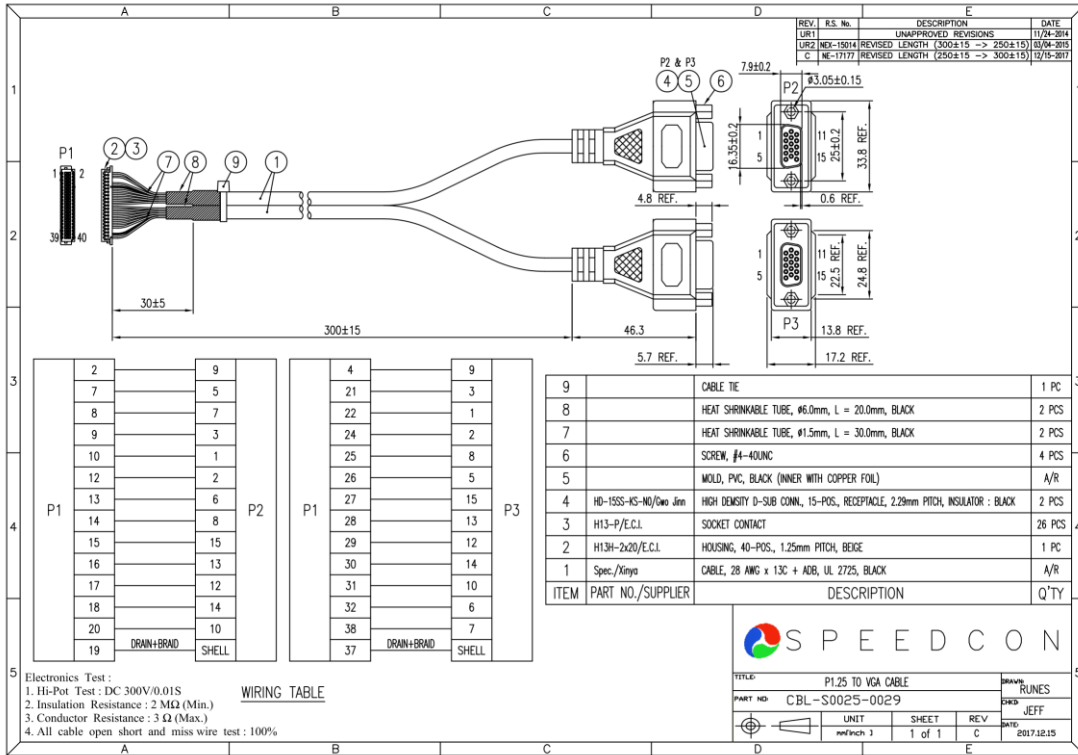

Figure 5: VGA Cable Drawing

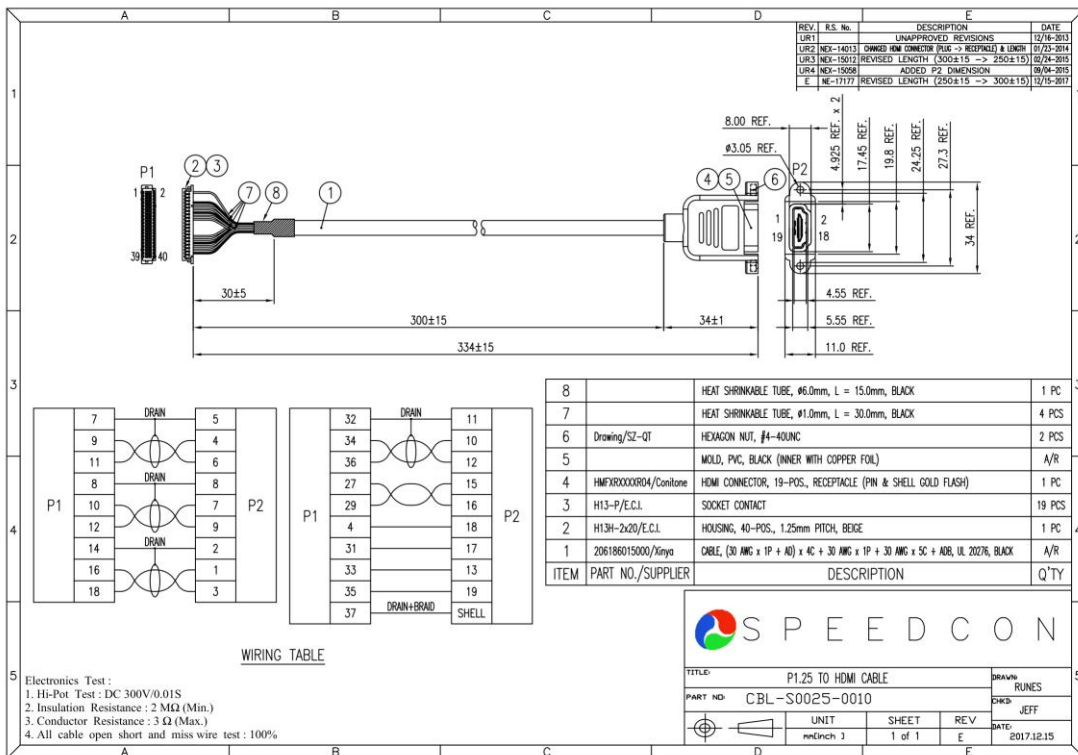

Figure 6: HDMI Cable Drawing



### 2.6.6. Packing List

- EMPV-1201 x1

### 2.7. Software Support

- Windows: XP (32 bit), Windows 7/8/8.1/10 (32/64 bit)
- Linux: Ubuntu 12.04-16.04(32/64bit), Linux Fedora 17-21(32/64bit), Linux CentOS/Redhat 6.5 (32/64bit)-7.2(64bit)

## 3. Installation Guide

Please download driver and user manual from Myinnodisk web site.

<https://myinnodisk.innodisk.com/myinnodisk/Login.aspx>

## 4. Appedix

innodisk

宜鼎國際股份有限公司  
Innodisk Corporation  
REACH Declaration

Tel:(02)7703-3000 Fax:(02) 7703-3555 Internet: <https://www.innodisk.com/>

Innodisk Corporation pursues its social responsibility for global environmental preservation by committing to be compliant with REACH regulation (REGULATION (EC) No 1907/2006). We hereby confirm that the product(s) delivered to

Innodisk P/N	Description
All Innodisk EP Products	

- contain(s) **no** hazardous substances or constituents exceeding the defined threshold 0.1 % by weight in homogenous material if not otherwise specified, as described in the candidate list table currently including 209 substances and shown on the ECHA website (<http://echa.europa.eu/de/candidate-list-table>).
- contain(s) one or more hazardous substances or constituents exceeding 0.1 % by weight in homogenous material if not otherwise specified in candidate list table. Where the threshold value is exceeded, the substances in question are to be declared in accompanying Appendix A.
- Comply with REACH Annex XVII.

### Guarantor

Company name 公司名稱： Innodisk Corporation 宜鼎國際股份有限公司

Company Representative 公司代表人： Randy Chien 簡川勝

Company Representative Title 公司代表人職稱： Chairman 董事長

Date 日期： 2020 / 07 / 01

### RoHS 自我宣告書 (RoHS Declaration of Conformity)

#### Manufacturer Products: All Innodisk EM FLASH, DRAM and EP products

- 一、 宜鼎國際股份有限公司（以下稱本公司）特此保證售予貴公司之所有產品，皆符合歐盟 2011/65/EU 及 (EU) 2015/863 關於 RoHS 之規範要求。  
Innodisk Corporation declares that all products sold to the company, are complied with European Union RoHS Directive (2011/65/EU) and (EU) 2015/863 requirement.
- 二、 本公司同意因本保證書或與本保證書相關事宜有所爭議時，雙方宜友好協商，達成協議。  
Innodisk Corporation agrees that both parties shall settle any dispute arising from or in connection with this Declaration of Conformity by friendly negotiations.
- 三、 本公司聲明我們的產品符合 RoHS 指令的附件中 (7a)、(7c-I) 允許豁免。  
We declare, our products permitted by the following exemptions specified in the Annex of the RoHS directive.
- ※ (7a) Lead in high melting temperature type solders (i.e. lead-based alloys containing 85% by weight or more lead).
- ※ (7C-I) Electrical and electronic components containing lead in a glass or ceramic other than dielectric ceramic in capacitors, e.g. piezoelectric devices, or in a glass or ceramic matrix compound.

Name of hazardous substance	Limited of RoHS ppm (mg/kg)
鉛 (Pb)	< 1000 ppm
汞 (Hg)	< 1000 ppm
鎘 (Cd)	< 100 ppm
六價鉻 (Cr 6+)	< 1000 ppm
多溴聯苯 (PBBs)	< 1000 ppm
多溴二苯醚 (PBDEs)	< 1000 ppm
鄰苯二甲酸二(2-乙基己基)酯 (DEHP)	< 1000 ppm
鄰苯二甲酸丁酯苯甲酯 (BBP)	< 1000 ppm
鄰苯二甲酸二丁酯 (DBP)	< 1000 ppm
鄰苯二甲酸二異丁酯 (DIBP)	< 1000 ppm

#### 立保證書人 (Guarantor)

Company name 公司名稱: Innodisk Corporation 宜鼎國際股份有限公司

Company Representative 公司代表人: Randy Chien 簡川勝

Company Representative Title 公司代表人職稱: Chairman 董事長

Date 日期: 2020 / 03 / 03



# Certificate

Issue Date: December 3, 2014  
Ref. Report No. ISL-14LE504CE

Product Name : Display Module  
Model(s) : E%PV-120\* (% : form factor (2: 2.5" SSD, 3. DDR3 DIMM, D: Dongle,  
G: NGFF, M.2, H: mPCIe Half, L: PCIe Low profile, M: mPCIe,  
S: PCIe Standard, X: Multi, Z: Others)\* : Series (1~9, A~Z))  
Responsible Party : Innodisk Corporation  
Address : 5F.No.237, Sec. 1, Datong Rd., Xizhi Dist., New Taipei City 221,  
Taiwan (R.O.C.)

We, **International Standards Laboratory**, hereby certify that:

The device bearing the trade name and model specified above has been shown to comply with the applicable technical standards as indicated in the measurement report and was tested in accordance with the measurement procedures specified in European Council Directive- EMC Directive 2004/108/EC. The device was passed the test performed according to :



#### Standards:

EN 55022: 2010+AC2011 and CISPR 22: 2008 (modified)  
EN 61000-3-2: 2006+A1:2009 +A2:2009 and IEC 61000-3-2: 2005+A1:2008 +A2:2009  
EN 61000-3-3: 2013 and IEC 61000-3-3: 2013  
EN 55024: 2010 and CISPR 24: 2010  
EN 61000-4-2: 2009 and IEC 61000-4-2: 2008  
EN 61000-4-3: 2006+A1: 2008 +A2: 2010 and  
IEC 61000-4-3:2006+A1: 2007+A2: 2010  
EN 61000-4-4:2012 and IEC 61000-4-4:2012

I attest to the accuracy of data and all measurements reported herein were performed by me or were made under my supervision and are correct to the best of my knowledge and belief. I assume full responsibility for the completeness of these measurements and vouch for the qualifications of all persons taking them.

#### International Standards Laboratory

*Jim Chu*  
Jim Chu / Director

#### Hsi-Chih LAB:

No. 65, Gu Dai Keng Street, Hsi-Chih Dist.,  
New Taipei City 221, Taiwan  
Tel: 886-2-2646-2550; Fax: 886-2-2646-4641



#### Lung-Tan LAB:

No. 120, Lane 180, San Ho Tsuen, Hsin Ho Rd.,  
Lung-Tan Hsiang, Tao Yuan County 325, Taiwan  
Tel: 886-3-407-1718; Fax: 886-3407-1738





# Certificate

Issue Date: December 3, 2014  
Ref. Report No. ISL-14LE504FB

Product Name : Display Module  
Model(s) : E%PV-120\* (% : form factor (2: 2.5" SSD, 3. DDR3 DIMM, D: Dongle, G: NGFF, M.2, H: mPCIe Half, L: PCIe Low profile, M: mPCIe, S: PCIe Standard, X: Multi, Z: Others)\* : Series (1~9, A~Z))  
Applicant : Innodisk Corporation  
Address : 5F.No.237, Sec. 1, Datong Rd., Xizhi Dist., New Taipei City 221, Taiwan (R.O.C.)

We, **International Standards Laboratory**, hereby certify that:

The device bearing the trade name and model specified above has been shown to comply with the applicable technical standards as indicated in the measurement report and was tested in accordance with the measurement procedures specified. (refer to Test Report if any modifications were made for compliance).



## Standards:

FCC CFR Title 47 Part 15 Subpart B: 2012- Section 15.107 and 15.109  
ANSI C63.4-2009  
Industry Canada Interference-Causing Equipment Standard ICES-003 Issue 5: 2012

## Class B

I attest to the accuracy of data and all measurements reported herein were performed by me or were made under my supervision and are correct to the best of my knowledge and belief. I assume full responsibility for the completeness of these measurements and vouch for the qualifications of all persons taking them.

## International Standards Laboratory

*Jim Chu*  
Jim Chu / Director

**Hsi-Chih LAB:**  
No. 65, Gu Dai Keng Street, Hsi-Chih Dist.,  
New Taipei City 221, Taiwan  
Tel: 886-2-2646-2550; Fax: 886-2-2646-4641



**Lung-Tan LAB:**  
No. 120, Lane 180, San Ho Tsuen, Hsin Ho Rd.,  
Lung-Tan Hsiang, Tao Yuan County 325, Taiwan  
Tel: 886-3-407-1718; Fax: 886-3407-1738



# Contact us

## Headquarters (Taiwan)

5F., No. 237, Sec. 1, Datong Rd., Xizhi Dist., New Taipei City 221, Taiwan

Tel: +886-2-77033000

Email: sales@innodisk.com

## Branch Offices:

### USA

usasales@innodisk.com

+1-510-770-9421

### Europe

eusales@innodisk.com

+31-40-3045-400

### Japan

jpsales@innodisk.com

+81-3-6667-0161

### China

sales\_cn@innodisk.com

+86-755-2167-3689

**[www.innodisk.com](http://www.innodisk.com)**

© 2020 Innodisk Corporation.

All right reserved. Specifications are subject to change without prior notice.

October 9, 2025