

# TG500G7

## 5.5" ARM A78 + A55 Android Rugged Tablet Controller



### KEY FEATURES

- 1920 x 1080 TFT LCD Panel with direct bonding
- Genio 510 2 x A78 2.0GHz + 4 x A55 2.0GHz
- All-weather, dust, and water-resistant design (IP65). MIL-grade drop, Shock and vibration
- Compact and ergonomic design
- Supports WIFI/BT

### INTRODUCTION

Winmate's 5.5-inch Android rugged tablet controller offers portable performance in a compact design for frontline mobility. It's 1920 × 1080 TFT LCD panel with direct bonding delivers sharp visuals, while the ergonomic form factor ensures ease of use in the field. Powered by the Genio 510 processor with Android OS, it supports reliable connectivity via Wi-Fi and Bluetooth. Built to IP65 and MIL-STD standards, this device withstands dust, water, drops, shock, and vibration for dependable all-weather durability.

### SPECIFICATIONS

#### Display

<b>Bonding</b>	Optical Bonding for Sunlight Visibility	<b>Resolution</b>	1920x1080
<b>Size</b>	5.5 inches	<b>Contrast Ratio</b>	1000:1
<b>Panel Brightness</b>	1000.0 nits	<b>View Angles</b>	80,80,80,80
<b>Type</b>	Projected Capacitive Multi Touch	<b>Viewability</b>	Anti-Glare touch treatment
<b>Touch Mode</b>	Support Hand / Gloves and Rain Mode		

#### System Specification

<b>Processor</b>	Genio 510 2 x A78 2.2GHz + 4 x A55 2.0GHz	<b>Memory</b>	4GB
<b>Storage</b>	64GB eMMC	<b>Operating System</b>	Android 13.0
<b>WLAN</b>	Support	<b>BT</b>	Support

#### Mechanical

<b>Dimension</b>	204.2 x 135.1 x 46 mm	<b>Cooling System</b>	Fanless Design
------------------	-----------------------	-----------------------	----------------

#### IO Ports

<b>USB Port</b>	1 x USB 3.0 (Type C)	<b>SD Card Slot</b>	1 x Micro SD Card Slot (Max to 2TB)
<b>Video</b>	1 x micro HDMI output	<b>Audio</b>	2x Speaker
<b>LAN</b>	1 x M10 LAN Connector (10/100 Mbps , Max to 250 Mbps) (optional)		

#### Environment

<b>Operating Humidity</b>	10% to 90% RH, non-condensing	<b>Operating Temperature</b>	-20°C to 60°C (AC mode), -10°C to 50°C (Battery mode)
<b>Storage Temperature</b>	-30°C to 70°C (-22°F to 158°F)	<b>Shock</b>	MIL-STD-810H Method 516.8 Procedure I
<b>Vibration</b>	MIL-STD-810H Method 514.8 Procedure I	<b>IP rating</b>	IP65

#### Certification

Certification CE, FCC

**Control**

Button 8 x Buttons

**Power**

Battery 3.7V, typ. 3200mAh Rechargeable Lithium Battery (2S1P)

Battery Operating Time 2 batteries: 8hrs  
4 batteries: 16hrs (optional)

Power Rating 19V DC

Adapter 100-240V, 50-60Hz / 19V DC

**Accessory**

Accessory 1 x PD Adapter 100W  
1 x Power Cord

Optional Accessory Shoulder Strap  
Microhard 2450  
1 x M10 LAN external cable(2M)  
2 x Antenna (optional for RF module)

**DIMENSIONS** UNIT:MM

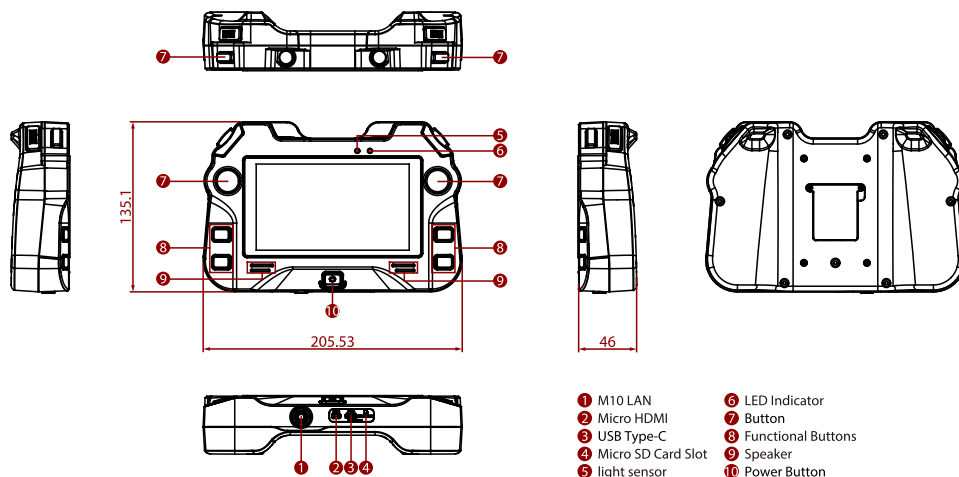

**NOTE**

- 1.This is a simplified drawing and some components are not marked in detail.
- 2.Please contact our sales representative if you need further product information.
- 3.All specifications are subject to change without prior notice.
- 4.The product shown in this datasheet is a standard model.For diagrams that contain customized or optional I/O, please contact the Winmate Sales Team for more information.