

Full IP67 Stainless Resistive Panel PC

Intel® Celeron® Elkhart Lake N6211 processor

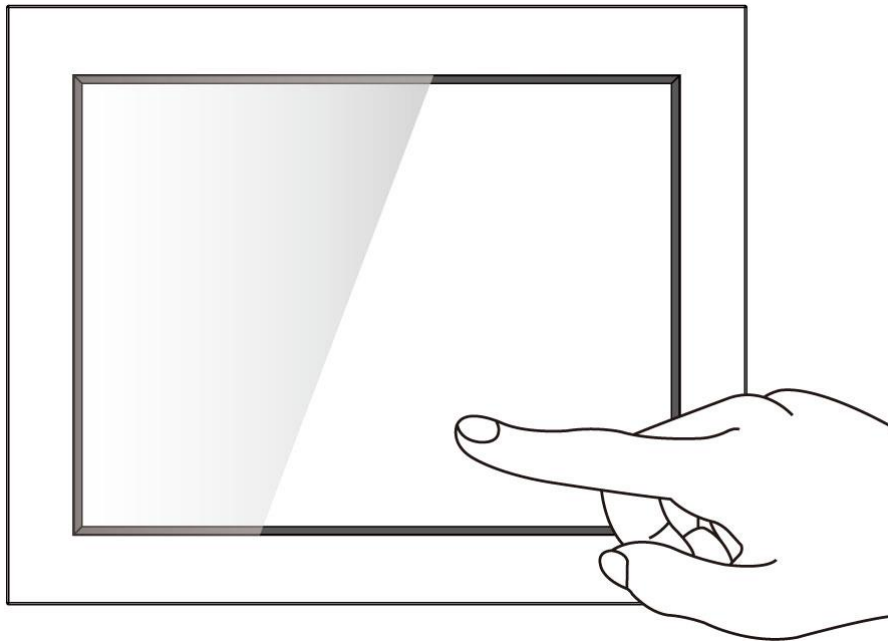

Model No. R10IE3S-67T2ST
R15IE3S-67C3ST
R17IE3S-67M1ST
R19IE3S-67M1ST

Quick Start Guide

Contents

1. Introduction	5
1.1 Features	5
1.2 Package Contents	6
1.3 Product Overview	7
1.3.1 Dimensions 10.4"	7
1.3.2 Dimensions 15"	7
1.3.1 Dimensions 17"	8
1.3.3 Dimensions 19"	8
1.4 Connectors	8
1.5 Physical Buttons and LED Indicators	9
2. Getting Started	10
2.1 Turning on Your Device	10
2.2 How to Enable Watchdog	10
2.3 Turning off Your Device	11
3. Installation	12
3.1 Wiring Requirements	12
3.2 Connector Pin Assignment	12
3.2.1 Power Cable	13
3.2.2 Serial Cable	13
3.2.3 Ethernet Cable	14
3.2.4 USB 2.0 Cable	14
3.3 Mounting	15
3.3.1 VESA Mounting	15
3.3.2 Yoke Mounting	15
4 Specifications	16
Appendix A: Cleaning the Monitor	18
Appendix B: Winmate Software Development Kit	18

FCC Statement



This device complies with part 15 FCC rules.

Operation is subject to the following two conditions:

- This device may not cause harmful interference.
- This device must accept any interference received including interference that may cause undesired operation.

This equipment has been tested and found to comply with the limits for a class "B" digital device, pursuant to part 15 of the FCC rules. These limits are designed to provide reasonable protection against harmful interference when the equipment is operated in a commercial environment. This equipment generates, uses, and can radiate radio frequency energy and, if not installed and used in accordance with the instruction manual, may cause harmful interference to radio communications. Operation of this equipment in a residential area is likely to cause harmful interference in which case the user will be required to correct the interference at his own expense.

European Union



Electromagnetic Compatibility Directive (2014/30/EU)

- EN55024: 2010/ A1: 2015
 - IEC61000-4-2: 2009
 - IEC61000-4-3: 2006+A1: 2007+A2: 2010
 - IEC61000-4-4: 2012
 - IEC61000-4-5: 2014
 - IEC61000-4-6: 2014
 - IEC61000-4-8: 2010
 - IEC61000-4-11: 2004
- EN55032: 2012/AC:2013
- EN61000-3-2:2014
- EN61000-3-3:2013

Low Voltage Directive (2014/35/EU)

- EN 60950-1:2006/A11:2009/A1:2010/A12:2011/ A2:2013

This equipment is in conformity with the requirement of the following EU legislations and harmonized standards. Product also complies with the Council directions.

Copyright Notice

No part of this document may be reproduced, copied, translated, or transmitted in any form or by any means, electronic or mechanical, for any purpose, without the prior written permission of the original manufacturer.

Trademark Acknowledgement

Brand and product names are trademarks or registered trademarks of their respective owners.

Disclaimer

Winmate Inc. reserve the right to make changes, without notice, to any product, including circuits and/or software described or contained in this manual in order to improve design and/or performance. We assume no responsibility or liability for the use of the described product(s) conveys no license or title under any patent, copyright, or masks work rights to these products, and make no representations or warranties that these products are free from patent, copyright, or mask work right infringement, unless otherwise specified. Applications that are described in this manual are for illustration purposes only. We make no representation or guarantee that such application will be suitable for the specified use without further testing or modification.

Warranty

Winmate Inc. warranty guarantees that each of its products will be free from material and workmanship defects for a period of one year from the invoice date. If the customer discovers a defect, we will, at his/her option, repair or replace the defective product at no charge to the customer, provide it is returned during the warranty period of one year, with transportation charges prepaid. The returned product must be properly packaged in its original packaging to obtain warranty service. If the serial number and the product shipping data differ by over 30 days, the in-warranty service will be made according to the shipping date. In the serial numbers the third and fourth two digits give the year of manufacture, and the fifth digit means the month (e. g., with A for October, B for November and C for December).

For example, the serial number 1W16Axxxxxxx means October of year 2016.

Customer Service

We provide a service guide for any problem by the following steps: First, visit the website of our distributor to find the update information about the product. Second, contact with your distributor, sales representative, or our customer service center for technical support if you need additional assistance.

You may need the following information ready before you call:

- Product serial number
- Software (OS, version, application software, etc.)
- Description of complete problem
- The exact wording of any error messages

In addition, free technical support is available from our engineers every business day. We are always ready to give advice on application requirements or specific information on the installation and operation of any of our products.

Safety Information

WARNING! / AVERTISSEMENT!



Always completely disconnect the power cord from your chassis whenever you work with the hardware. Do not make connections while the power is on. Sensitive electronic components can be damaged by sudden power surges. Only experienced electronics personnel should open the PC chassis.

Toujours débrancher le cordon d'alimentation du chassis lorsque vous travaillez sur celui-ci. Ne pas brancher de connexions lorsque l'alimentation est présente. Des composants électroniques sensibles peuvent être endommagés par des sauts d'alimentation. Seulement du personnel expérimenté devrait ouvrir ces chassis.

CAUTION/ATTENTION



Always ground yourself to remove any static charge before touching the CPU card. Modern electronic devices are very sensitive to static electric charges. As a safety precaution, use a grounding wrist strap at all times. Place all electronic components in a static-dissipative surface or static-shielded bag when they are not in the chassis.

Toujours vérifier votre mise à la terre afin d'éliminer toute charge statique avant de toucher la carte CPU. Les équipements électroniques modernes sont très sensibles aux décharges d'électricité statique. Toujours utiliser un bracelet de mise à la terre comme précaution. Placer toutes les composantes électroniques sur une surface conçue pour dissiper les charge, ou dans un sac anti-statique lorsqu'elles ne sont pas dans le chassis.

1. Introduction

Congratulations on purchasing Winmate® IP67 Stainless Resistive Panel PC. Winmate® IP67 Stainless Resistive Panel PC is rugged, industrial-grade panel PC series built to withstand challenging environments, undergoing rigorous testing to ensure safety and top performance. All of the models in the series are sealed to IP67 standard. Stainless housing features anti-corrosion properties making it suitable for food, chemical and pharmaceutical industries.

Wimate® IP67 Stainless Resistive Panel PC goes beyond that of the standard industrial panel computers with rugged construction, powerful performance, and flexible mounting options.

1.1 Features

Wimate® IP67 Stainless Resistive Panel PC features:

- 10.4", 15" , 17" and 19"
- Intel® Celeron Elkhart Lake N6211 Processor
- Fanless Design
- Full IP67 dust and water resistant
- Stainless Housing with anti-corrosion treatment
- Various mounting solutions: Yoke mount and VESA mount
- Resistive Touch Screen Bonding With Panel
- Protection Glass Without touch function (Optional)

1.2 Package Contents

Carefully remove the box and unpack your device. Please check if all the items listed below are inside your package. If any of these items are missing or damaged contact us immediately.

Standard factory shipment list:

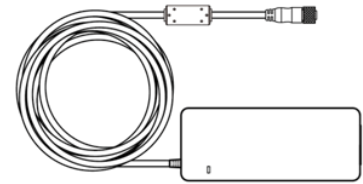
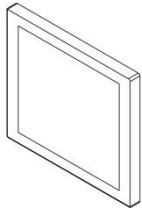

Panel PC

**IP67 Stainless Resistive
Panel PC Quick Start Guide
(Hardcopy)**

AC Adapter

Varies by product specifications

Part No.91521110111B

50W 90PO12050002
80W 90PO12080003

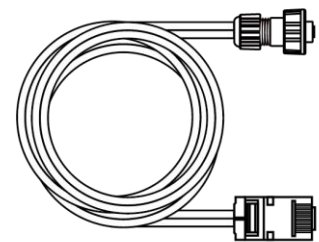
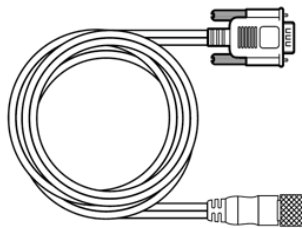
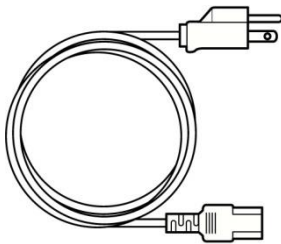

Power Cable

Serial Cable

Ethernet Cable Part No. 94I0080080KF rnet
Cable

Varies by destination

Part No. 94G0123090Q0

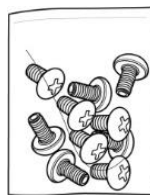
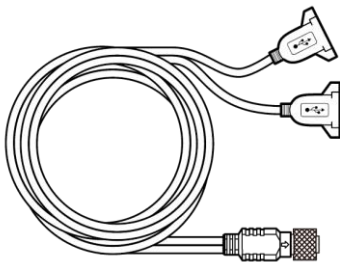

USB Cable

VESA Screws

Part No. 9480128080K0

Part No. 913511101101

1.3 Product Overview

This section contains mechanical drawing of the Panel PC. Notice that this is a simplified drawing and some components are not marked in detail.

1.3.1 Dimensions 10.4"

Unit: mm

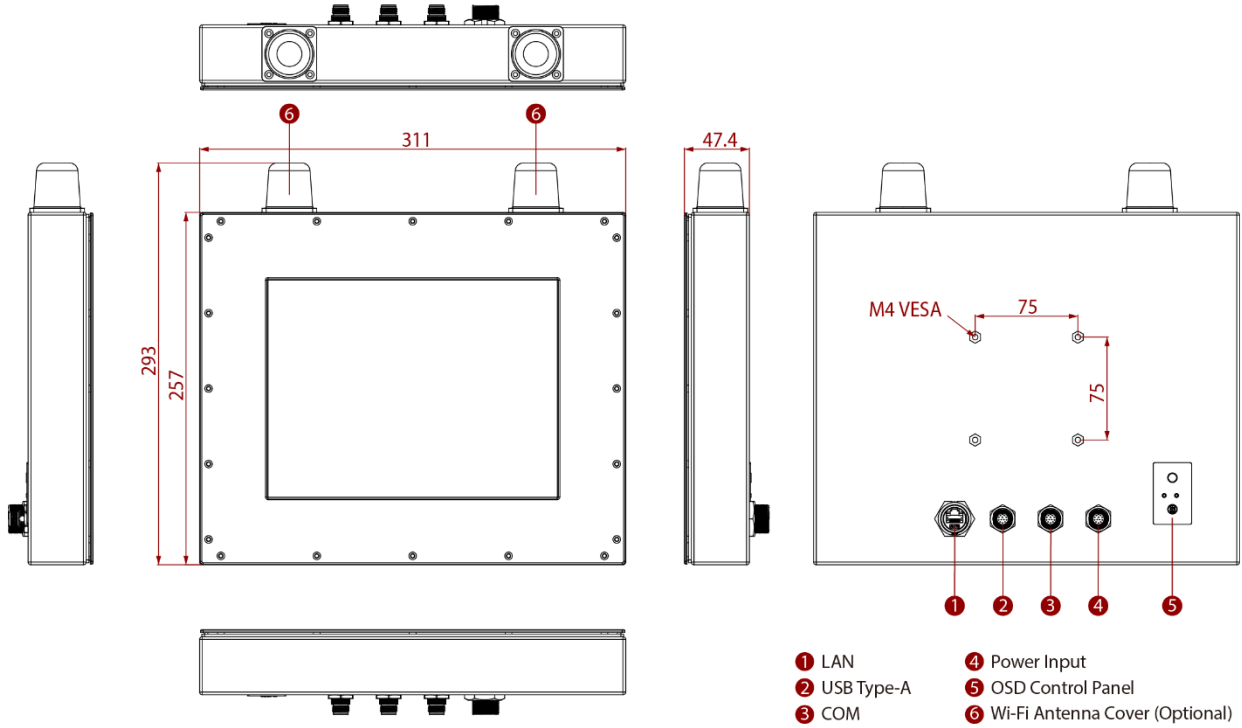

1.3.2 Dimensions 15"

Unit: mm

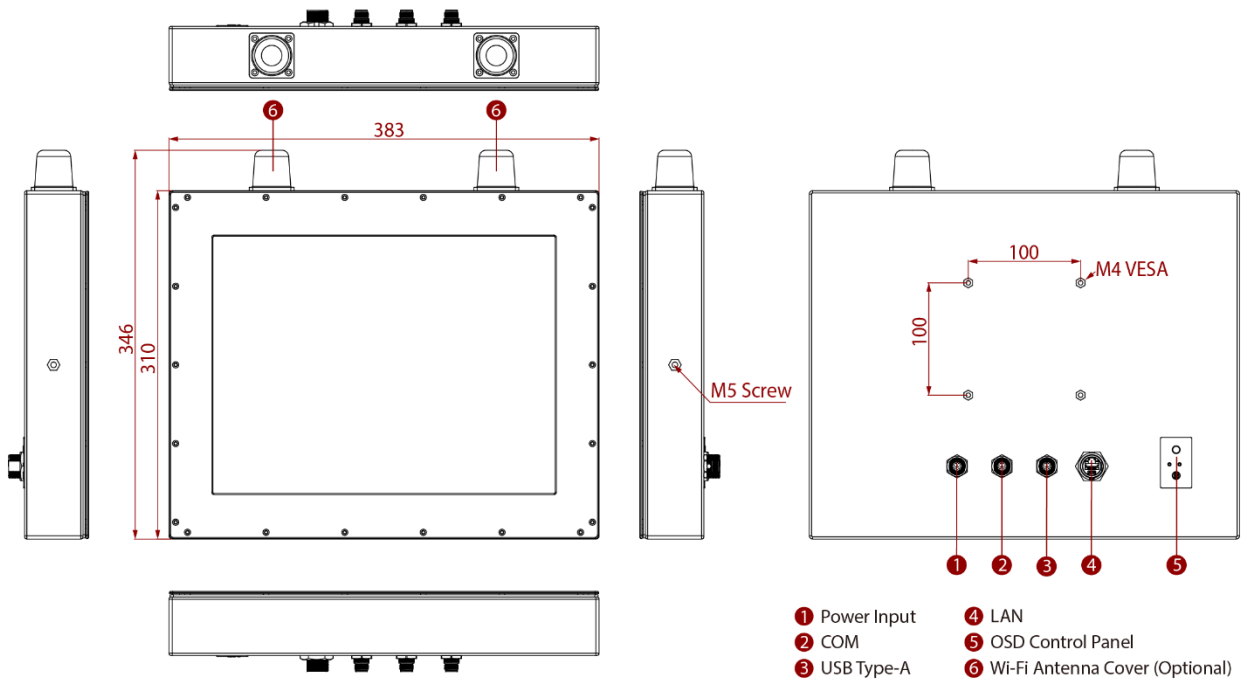

1.3.1 Dimensions 17"

Unit: mm

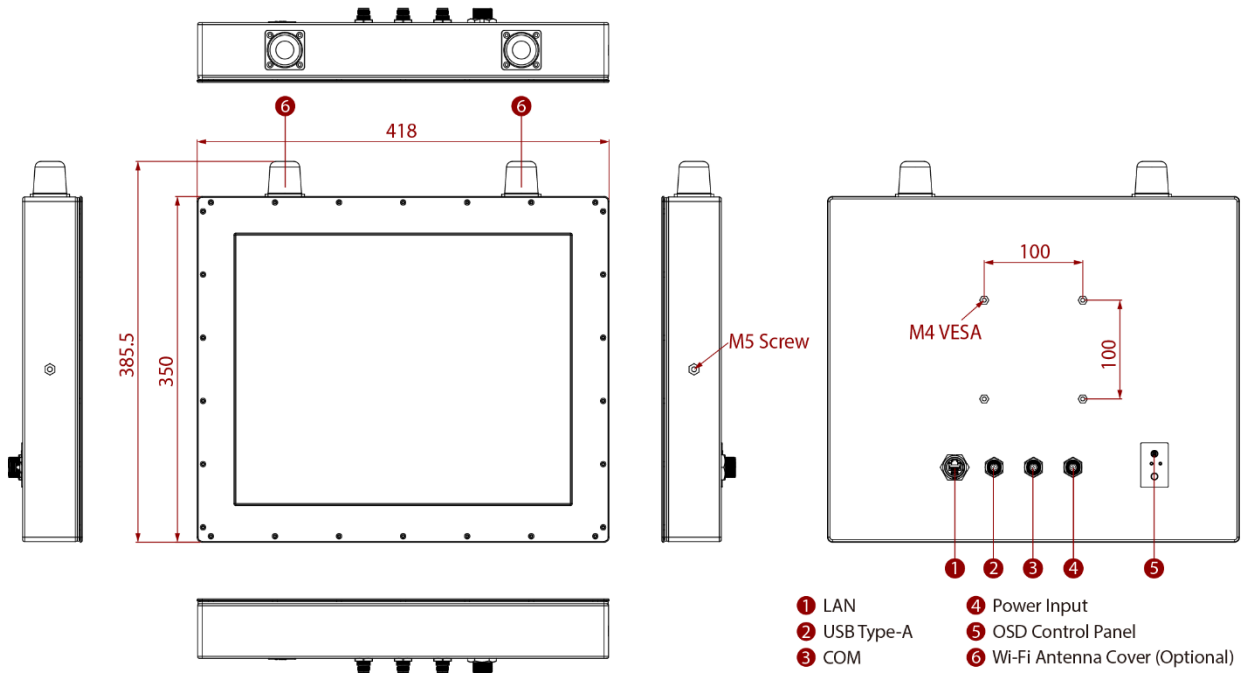

1.3.3 Dimensions 19"

Unit: mm

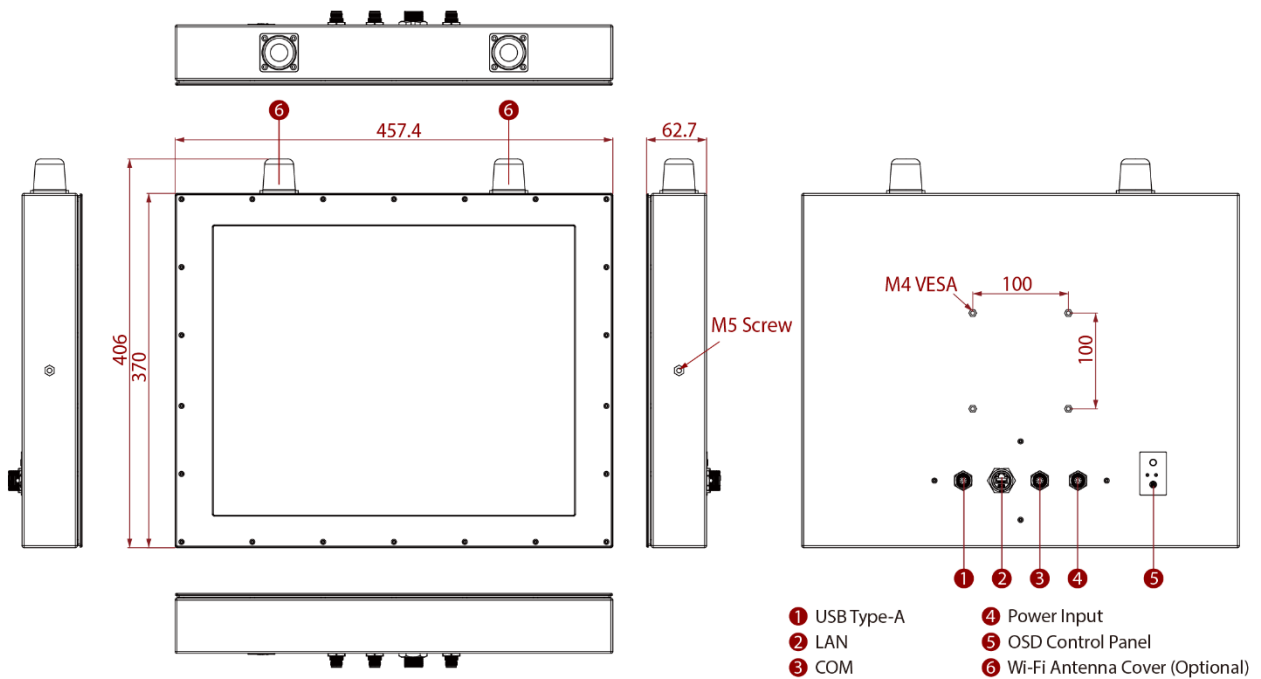

1.4 Connectors



IP67 Stainless Resistive Panel PC has IP67 type connectors with protection cap.

1.5 Physical Buttons and LED Indicators

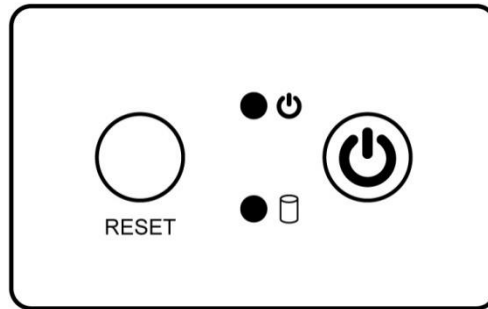

Physical buttons and LED indicators located on the rear side of the Panel PC.

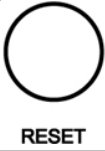

Physical Buttons

Icon	Button	Description
	Reset	Press to reset the system
	Power On/ Off	Press to power on or power off the device

LED Indicators

LED Type	Status	Description
	On	Power is on
	Off	Power is off
	Blinking	Storage activity (Data is being read or written)
	Off	System is idle

2. Getting Started

2.1 Turning on Your Device

Follow the following steps to turn on your device:

1. Connect the AC adapter to the DC-in jack connector on the back side of the Panel PC.
2. Connect the power cord to AC adapter.
3. Plug the power cord to the AC outlet and the device will turn on automatically.

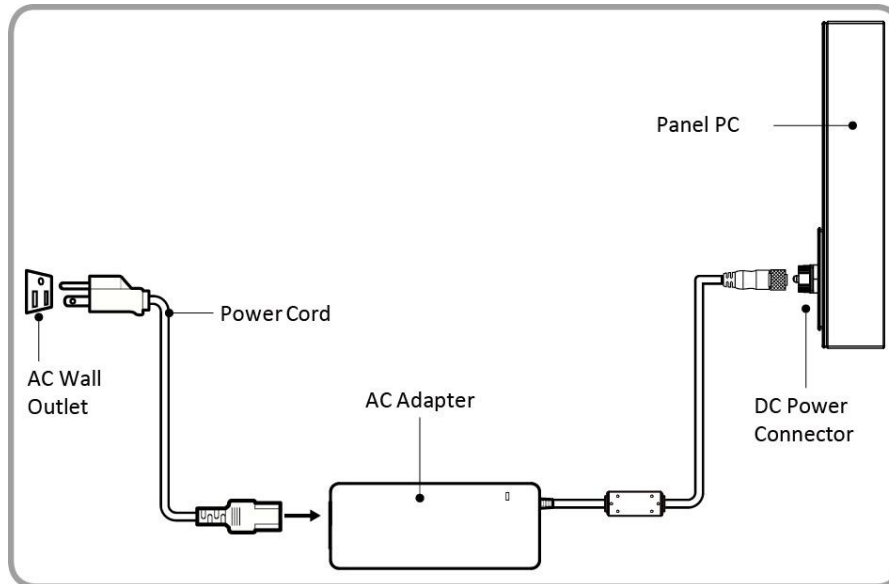

AC Adapter specifications vary by panel size.



Size	10.4"	15"	17"	19"
AC Adapter	12V/ 50W	12V/ 50W	12V/ 50W	12V/ 80W
Power Consumption*	33W (typ.)	38W (typ.)	43W (typ.)	45W (typ.)

**With maximum backlight and high CPU load.*

2.2 How to Enable Watchdog

To enable Watchdog, you need to download Winmate Watchdog utility. Find more information on Watchdog in "Watchdog Guide" that you can download from Winmate Download Center or File Share. Refer to the User Manual for more details.

To enable watchdog in Watchdog AP follow the instructions below:

1. On the right bottom side of the desktop screen, click  **triangle button** to show hidden icons.
2. Click  icon to open Watchdog utility.

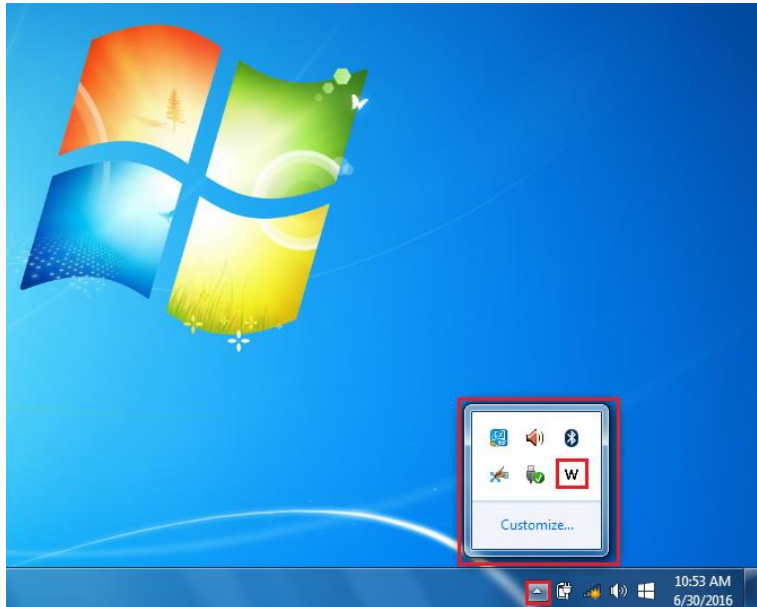

3. In Watchdog utility window set countdown time and periodically feed time, or disable watchdog.

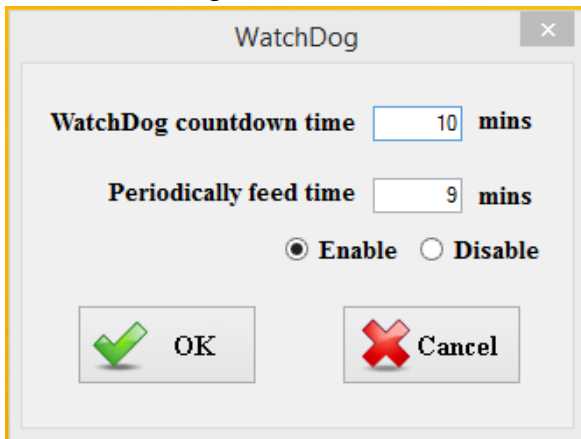

Example:

Every 10 min watchdog will monitor the system, in case any error occurs the system will restart automatically when the countdown time reaches 0.

Every 9 min watchdog timer will be reset to 10 min.

Settings	Description
Watchdog Countdown Time	The system automaticity restarts when this countdown time reaches zero. <i>Default: 10 min</i>
Periodically Feed Time	To set a cycle time to automatically reset watchdog timer. <i>Default: 9 min</i>
Enable / Disable	Enable or disable watchdog. <i>Default: Enable</i>

2.3 Turning off Your Device

To shut down your device, do the following:

Tap **Start** () > **Shut down**. Wait for your Panel PC to completely turn off before disconnecting the power cord (if necessary).

3. Installation

3.1 Wiring Requirements

The following common safety precautions should be observed before installing any electronic device:

- Strive to use separate, non-intersecting paths to route power and networking wires. If power wiring and device wiring paths must cross make sure the wires are perpendicular at the intersection point.
- Keep the wires separated according to interface. The rule of thumb is that wiring that shares similar electrical characteristics may be bundled together.
- Do not bundle input wiring with output wiring. Keep them separate.
- When necessary, it is strongly advised that you label wiring to all devices in the system.
- Do not run signal or communication wiring and power wiring in the same conduit. To avoid interference, wires with different signal characteristics (i.e., different interfaces) should be routed separately.
- Be sure to disconnect the power cord before installing and/or wiring your device.
- Verify the maximum possible current for each wire gauge, especially for the power cords. Observe all electrical codes dictating the maximum current allowable for each wire gauge.
- If the current goes above the maximum ratings, the wiring could overheat, causing serious damage to your equipment.
- Be careful when handling the unit. When the unit is plugged in, the internal components generate a lot of heat which may leave the outer casing too hot to touch.

3.2 Connector Pin Assignment

This Panel PC is equipped with four connectors which are IP67 level and fool-proofing design. Use only the cables that are included in the package. The pin assignments of the cables are as follows.

3.2.1 Power Cable

The IP67 Stainless Resistive Panel PC has IP67 connector. Use power cable to connect Panel PC to the source of power.

IP67 Stainless Resistive Panel PC supports 12V DC power input.

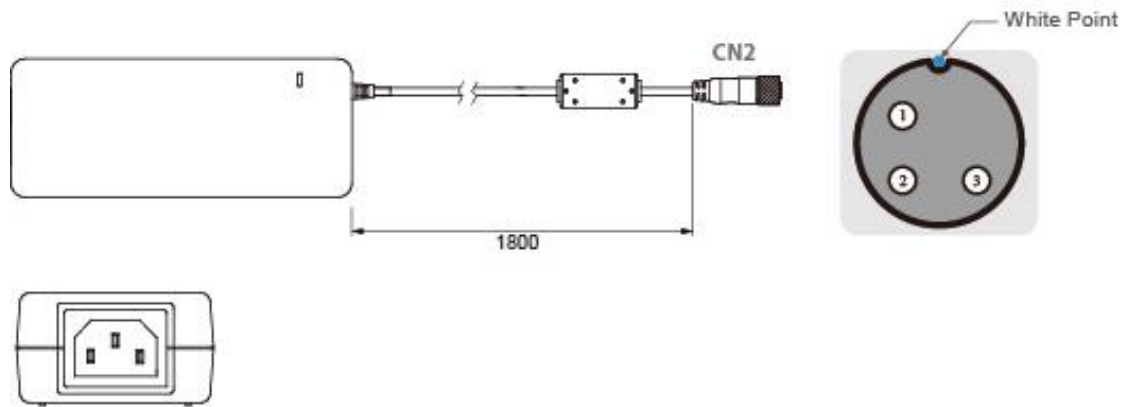

Pin No.	Symbols	Color		Pin No.	Symbols	Color
CN1-1	VIN -	NO ASSIGN	↔	CN2-1	VCC+	Flow Adapter
CN1-2	VIN -	NO ASSIGN	↔	CN2-2	GND	Flow Adapter
CN1-3	VIN -	NO ASSIGN	↔	CN2-3	VCC -	Flow Adapter

3.2.2 Serial Cable

The IP67 Stainless Resistive Panel PC has IP67 serial port connector. Use serial cable to connect serial interfaces.

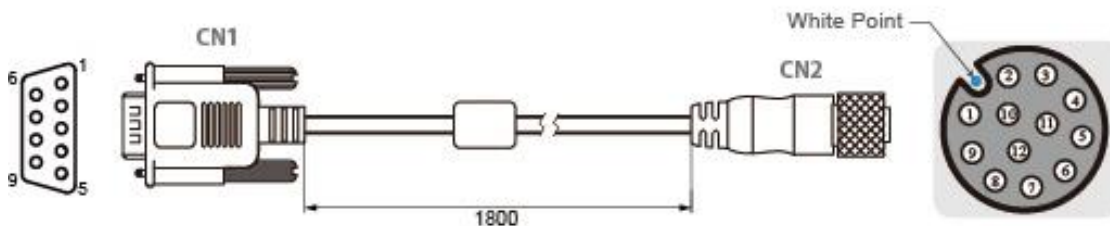

Pin No.	Symbols	Color		Pin No.	Symbols	Color
CN1-1	DCD-CON2	Green	↔	CN2-1	DCD-CON2	Green
CN1-6	DSR-CON2	Brown	↔	CN2-2	DSR-CON2	Brown
CN1-2	RXD-CON2	Red	↔	CN2-3	RXD-CON2	Red
CN1-7	RTS-CON2	Orange	↔	CN2-4	RTS-CON2	Orange
CN1-3	TXD-CON2	Blue	↔	CN2-5	TXD-CON2	Blue
CN1-8	CTS-CON2	White	↔	CN2-6	CTS-CON2	White
CN1-4	DTR-CON2	Purple	↔	CN2-7	DTR-CON2	Purple
CN1-9	RI-CON2	Yellow	↔	CN2-8	RI-CON2	Yellow
CN1-5	GND-CON2	Black	↔	CN2-9	GND-CON2	Black

3.2.3 Ethernet Cable

The IP67 Stainless Resistive Panel PC has IP67 Ethernet connector. Use Ethernet cable to connect the Panel PC to the Internet.

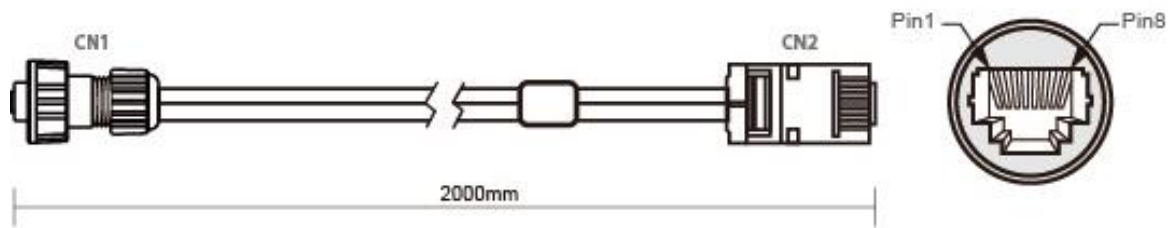

Pin No.	Color	↔	Pin No.	Color
CN1-1	White/Orange	↔	CN2-1	White/Orange
CN1-2	Orange	↔	CN2-2	Orange
CN1-3	White/Green	↔	CN2-3	White/Green
CN1-4	Blue	↔	CN2-4	Blue
CN1-5	White/Blue	↔	CN2-5	White/Blue
CN1-6	Green	↔	CN2-6	Green
CN1-7	White/Brown	↔	CN2-7	White/Brown
CN1-8	Brown	↔	CN2-8	Brown

3.2.4 USB 2.0 Cable

The IP67 Stainless Resistive Panel PC has one Full IP67 USB2.0 connector. Use USB2.0 cable to connect external devices such as mouse or keyboard to the Panel PC.

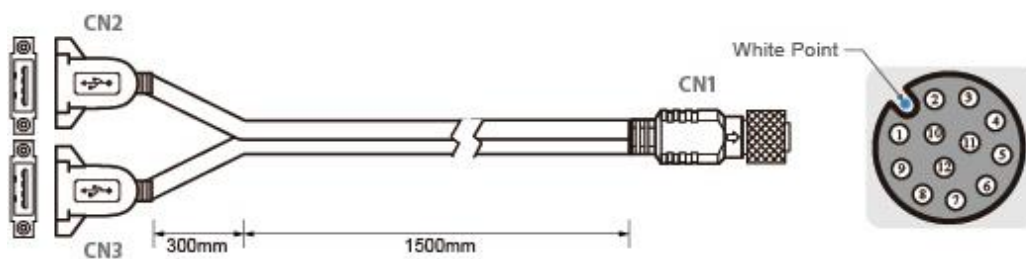

Pin No.	Symbols	Color	↔	Pin No.	Symbols	Color
CN1-2	VCC	RED	↔	CN2-1	VCC	RED
CN1-3	D-	WHITE	↔	CN2-2	D-	WHITE
CN1-4	D+	GREEN	↔	CN2-3	D+	GREEN
CN1-5	GND	BLACK	↔	CN2-4	GND	BLACK
CN1-6	VCC	RED	↔	CN3-1	VCC	RED
CN1-7	D-	WHITE	↔	CN3-2	D-	WHITE
CN1-8	D+	GREEN	↔	CN3-3	D+	GREEN
CN1-9	GND	BLACK	↔	CN3-4	GND	BLACK
CN1-1	GND	Braid	↔	Braid connect to the housing		

} twisted pair
} twisted pair

3.3 Mounting

IP67 Stainless Resistive Panel PC devices come with different mounting options suitable for most of the industrial and commercial applications.

3.3.1 VESA Mounting

IP65 Stainless Resistive Panel PC has VESA mount holes on the rear side. Follow instructions below to mount the unit with VESA Mount bracket (not supplied by Winmate).

Size	VESA Plate Dimensions	Screw Hole Diameter
10.4", 15", 19"	100 x 100 mm	VESA M4x5 mm

Mounting Instruction:

1. Screw VESA bracket to the fixture (ex. swing arm) with four VESA screws.
2. Place the device on VESA bracket.

3.3.2 Yoke Mounting

Yoke Mount solution allows installing the Panel PC with the bracket (not supplied by Winmate).

Mounting instruction:

1. Place the Panel PC on the bracket stand, aiming screw holes for each other.
2. Secure screws to fix the device upon the bracket stand.
3. Firmly secure the locking handle to the Panel PC.

4 Specifications

Hardware Specifications

	Model Name			
	R10IE3S-67T2ST	R15IE3S-67C3ST	R17IE3S-67M1ST	R19IE3S-67M1ST
Display				
Size	10.4 inches	15 inches	17 inches	19 inches
Resolution	1024 x 768	1024 x 768	1280 x 1024	1280 x 1024
Panel Brightness	350 nits	300 nits	350 nits	250 nits
Contrast Ratio	1000 : 1	2000 : 1	1000 : 1	1000 : 1
View Angles	88,88,88,88	88,88,88,88	85,85,80,80	85,85,80,80
Touch/Glass	Resistive Touch Screen Bonding With Panel Protection Glass Without touch function (Optional)			
Active Area	210.4x157.8 mm	304.1x228.1 mm	337.920x270.336 mm	376.32x301.06 mm
System Specification				
Processor	Intel® Celeron® N6211 (1.5M Cache, up to 3.0GHz) Intel® Celeron® N6210 (1.5M Cache, up to 2.6GHz) (Optional)			
Memory	1 x SO-DIMM, DDR4 3200 MHz, 4GB 8GB (Optional) 16GB (Optional)			
Storage	1 x M.2 2242 B-key SSD 128GB M.2 2242 B-key SSD up to 512GB (Optional) 1 x SATA III for 2.5" SSD/HDD up to 1TB (Optional)			
Ethernet controller	2 x Intel® Ethernet Controller			
Security	TPM 2.0			
Operating System	Windows 11 IoT Enterprise SAC (64 bit) (Optional) Windows 10 IoT Enterprise (64 bit) (Optional) Linux Ubuntu 22.04 (Optional)			
BT	Support (Optional)			
WLAN	Support (Optional)			
IO Ports				
USB Port	1 x waterproof Giga LAN RJ45 connector			
Serial Port	1 x M12 waterproof connector for RS232			
LAN	1x M12 waterproof connector for 2 x USB2.0			
Indicator	1 x M12 waterproof connector for 12V DC			
Power Input	1 x LED Indicator for power 1 x LED Indicator for storage			

Control				
Button	1 x Power Button 1 x Reset Button			
Mechanical				
Dimension	311 x 257 x 47.4 mm	383 x 310 x 57 mm	418 x 350 x 59 mm	457.4 x 369.5 x 62.7 mm
Mounting	Yoke Mount, VESA Mount			
Cooling System	Fanless			
Enclosure	Stainless housing			
Environment				
Operating Temperature	0°C to +45°C			
Operating Humidity	10% to 90% (non-condensing)			
Storage Temperature	-20°C to 60°C			
IP Rating	IP67			
Certification				
Certification	CE, FCC			
Power				
Power Rating	12V DC (M12 type)			

Software support – Drivers

Item	Driver	Windows 10
1	Chipset Driver	<input checked="" type="checkbox"/>
2	Graphics Driver	<input checked="" type="checkbox"/>
3	Audio Driver	<input checked="" type="checkbox"/>
4	Intel Sideband Fabric Device (Intel MBI) Driver	<input checked="" type="checkbox"/>
5	Intel Trusted Engine Interface (Intel TXE) Driver	<input checked="" type="checkbox"/>
6	USB 3.0 Driver	<input type="checkbox"/>
7	Watchdog Driver	<input checked="" type="checkbox"/>

NOTE:

- Accessories and Integrated Options may vary depending on your configuration. The product shown in this document is a standard model. For diagrams that contain customized or optional I/O, please contact the Winmate Sales Team for more information.
- All specifications are subject to change without prior notice.

Appendix A: Cleaning the Monitor

Before cleaning:

- Make sure the device is turned off.
- Disconnect the power cable from any AC outlet.

When cleaning:

- Never spray or pour any liquid directly on the screen or case.
- Wipe the screen with a clean, soft, lint-free cloth. This removes dust and other particles.
- The display area is highly prone to scratching. Do not use ketene type material (ex. Acetone), Ethyl alcohol, toluene, ethyl acid or Methyl chloride to clear the panel. It may permanently damage the panel and void the warranty.
- If it is still not clean enough, apply a small amount of non-ammonia, non-alcohol based glass cleaner onto a clean, soft, lint-free cloth, and wipe the screen.
- Don not use water or oil directly on the display screen. If droplets are allowed to drop on the screen, permanent staining or discoloration may occur.

Appendix B: Winmate Software Development Kit

Winmate provides the following SDK and Utilities for the IP67 Stainless Resistive Panel PC.

Item	File Type	Description
1	SDK	Watchdog SDK
2	Utility	Watchdog Utility

To find the Drivers and SDK, please refer to the Driver CD that comes in the package or contact us. Also, you can download drivers from Winmate Download Center.

Winmate Download Center

Go to <http://www.winmate.com/> > Support > Download Center > Full IP67 Stainless PPC > IP67 Resistive PPC – Bay Trail



Contact Us

Winmate Inc.



No.18, Zhongxing South Rd.,
San-Chung District, New Taipei City 241017, Taiwan
Tel: +886-2-8511-0288
E-mail: sales@winmate.com.tw
Website: www.winmate.com

Winmate USA Inc.



2640 Matthews Street,
Smyrna, GA 30080, USA
Tel: +1-678-653-8800
E-mail: NASales@winmate.com.tw
Website: www.winmate-rugged.com

TTX Canada



150 Werlich Drive, Units 5&6
Cambridge, Ontario, N1T 1N6 Canada
Tel: +1-519-621-1881
E-mail: Sales@ttx.ca
Website: www.ttx.ca

TL Electronic GmbH



Bgm.-Gradl-Str. 1
85232 Bergkirchen-Feldgeding, Germany
Tel: +49 (0)8131 33204-0
E-mail: info@tl-electronic.de
Website: www.tl-electronic.de

京融电自动化科技（苏州）有限公司



215100 江苏省苏州市工业园区唯新路 69 号
一能科技园 3 号楼 206 室
Tel: +86-512-6826-6696/6829-6696
E-mail: sales@winmate.com.cn
Website: www.winmate.com.cn

Winmate JP Office/ HPC System Inc.



LOOP-X 8F,3-9-15 Kaigan,
Minato-ku, Tokyo 108-0022, Japan
Tel: +81-3-5446-5535
Fax: +81-3-5446-5550
Website: www.hpc.co.jp
