

## Features

- COM Express Rev. 3.1 Intel® 13th Generation Core™ Embedded Mobile Processor Type6 COMe Compact Module
- 1 x 262-Pin DDR5 4800MT/s SO-DIMM Up to 32GB
- 1 x Intel® I226LM/IT
- Intel® HD Audio Integrated on CPU
- Onboard nuvoTon\_NPCT754AADYX TPM 2.0 (Optional)
- COMe Type 6 Compact Size: 3.74" x 3.74" (95 x 95 mm)
- DC in +9V ~ +19V



DDR5  
SO-DIMM



USB 3.2



4 Display  
up to 4K  
(3DDI + eDP)

## Specifications

### System Information

Processor	13th Gen. Intel® P-Series Embedded Industrial (28 W) U-Series Embedded / Industrial (15 W)
System Memory	1 x 262-Pin DDR5 4800MT/s SO-DIMM Up to 32GB
I/O Chipset	EC iTE IT5782
Watchdog Timer	H/W Reset, 1Sec. ~ 65535Sec. and 1Sec./Step
BIOS	AMI uEFI BIOS, 256 Mbit SPI Flash ROM
H/W Status Monitor	Monitoring System Temperature Voltage and FAN Status with Auto Throttling Control
TPM	Onboard nuvoTon_NPCT754AADYX TPM 2.0 (Optional)

### Expansion

Expansion	2 x PCIe x4 (Gen4), Only for SSD, (From CPU) Default: 5 x PCIe x1 (Gen3), 2 x SATA (2 Lanes Shares with SATA)
-----------	--

### Display

Graphic Chipset	Intel® Iris® Xe Graphics on i7/i5 Processor Intel® UHD Graphics on i3/Celeron® Processor Intel® Gfx Up to 96 EU
Spec. & Resolution	3 x DDI, VGA, eDP/LVDS (BOM Optional) VGA Supported by Build Option Via DP-to-VGA IC, Max. Resolution 1920x1200@60Hz LVDS Single/Dual Channel 18/24-bit LVDS from eDP-to-LVDS IC, Max. Resolution 1920x1200@60Hz in Dual Mode or eDP Build Option in Place of LVDS, 4 lanes, eDP 1.4b (by BOM) USB4 Max. 2 x USB4 in Place of DDI 1/2, Supports DP 1.4a by DP Alternative Mode DDI3 for Avalue EX-EX26 Carrier HDMI 2.1 or DP 1.4a Select by BIOS, Support Feature Depend on Carrier Board.
Multiple Display	Four Display Support, Up to 4K (3DDI+eDP)
LVDS	CH7511B (eDP to LVDS)
DDI	3 x DDI, VGA, eDP/LVDS (BOM Optional) HDMI/DP (Default) VGA Supported by Build Option Via DP-to-VGA IC (In Place of DDI 3)

### Audio

Audio Interface	Intel® HD Audio Integrated on CPU
-----------------	-----------------------------------

### Ethernet

LAN Chipset	1 x Intel® I226LM/IT
Ethernet Interface	10/100/1000/2500 Base-Tx GbE Compatible

### Software Support

OS	Windows 11 64bit, Linux
----	-------------------------

### Certification

Certification Information	CE, FCC Class, RoHS Compliant
---------------------------	-------------------------------

### I/O

USB	2 x USB 4 by TCP Ports (Optional by BIOS) 4 x USB 3.2 Gen2 8 x USB 2.0
COM Port	2 x UART (RX/TX Only)
SATA	2 x SATA III
DIO	1 x 8-bit GPIO
MIO	1 x SMBus 1 x LPC (Via ESPI-to-LPC Bridge IC) 1 x GP_SPI (TBC) 1 x I <sup>2</sup> C

### Mechanical & Environmental

Operating Temp.	Standard 0°C ~ 60°C (32°F ~ 140°F) Extend: -40°C ~ 75°C (-40°F ~ 167°F)
Storage Temp.	-40°C ~ 85°C (-40°F ~ 185°F)
Operating Humidity	40°C @ 95% Relative Humidity, Non-condensing
Weight	0.44lbs (0.2Kg)
Power Requirement	+9V ~ +19V
Power Mode	AT/ATX
Dimension (L x W)	3.74" x 3.74" (95 x 95 mm)

## Mechanical Drawing

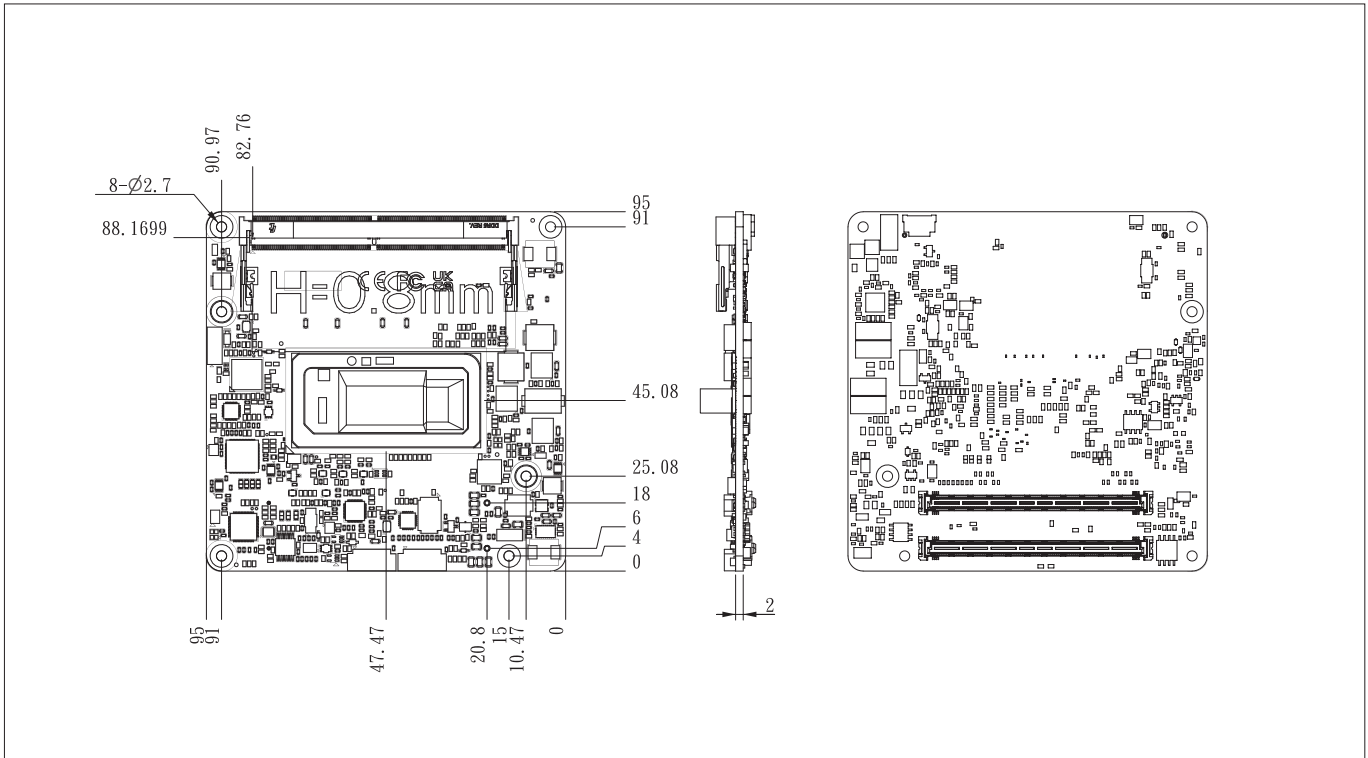

## Ordering Information

P/N	CPU	PCH	LVDS/eDP	TPM	Memory	Storage	Operating Temp.	Thermal Solution
ESM-RPLC-S65-A1R	Intel® Core™ i7-1365UE Processor	NA	LVDS	Onboard TPM 2.0	1	NA	0°C ~ 60°C (32°F ~ 140°F)	ACC-ESMRPLC-CL-1R W/FAN H=56mm
ESM-RPLC-S35-A1R	Intel® Core™ i5-1335UE Processor	NA	LVDS	Onboard TPM 2.0	1	NA	0°C ~ 60°C (32°F ~ 140°F)	ACC-ESMRPLC-CL-1R W/FAN H=56mm
ESM-RPLC-S15-A1R	Intel® Core™ i3-1315UE Processor	NA	LVDS	Onboard TPM 2.0	1	NA	0°C ~ 60°C (32°F ~ 140°F)	ACC-ESMRPLC-CL-1R W/FAN H=56mm
ESM-RPLC-S40-A1R	Intel® Core™ i5-1340PE Processor	NA	LVDS	Onboard TPM 2.0	1	NA	0°C ~ 60°C (32°F ~ 140°F)	ACC-ESMRPLC-CL-1R W/FAN H=56mm
ESM-RPLC-300-A1R	Intel® Processor U300E	NA	LVDS	Onboard TPM 2.0	1	NA	0°C ~ 60°C (32°F ~ 140°F)	ACC-ESMRPLC-CL-1R W/FAN H=56mm
ESM-RPLC-W65-A1R	Intel® Core™ i7-1365URE Processor	NA	LVDS	Onboard TPM 2.0	1	NA	-40°C ~ 75°C (-40°F ~ 167°F)	ACC-ESMRPLC-CL-2R W/FAN H=68.5mm
ESM-RPLC-W45-A1R	Intel® Core™ i5-1345URE Processor	NA	LVDS	Onboard TPM 2.0	1	NA	-40°C ~ 75°C (-40°F ~ 167°F)	ACC-ESMRPLC-CL-2R W/FAN H=68.5mm
ESM-RPLC-W15-A1R	Intel® Core™ i3-1315URE Processor	NA	LVDS	Onboard TPM 2.0	1	NA	-40°C ~ 75°C (-40°F ~ 167°F)	ACC-ESMRPLC-CL-2R W/FAN H=68.5mm
ESM-RPLC-W20-A1R	Intel® Core™ i3-1320PRE Processor	NA	LVDS	Onboard TPM 2.0	1	NA	-40°C ~ 75°C (-40°F ~ 167°F)	ACC-ESMRPLC-CL-2R W/FAN H=68.5mm

## I/O Overview

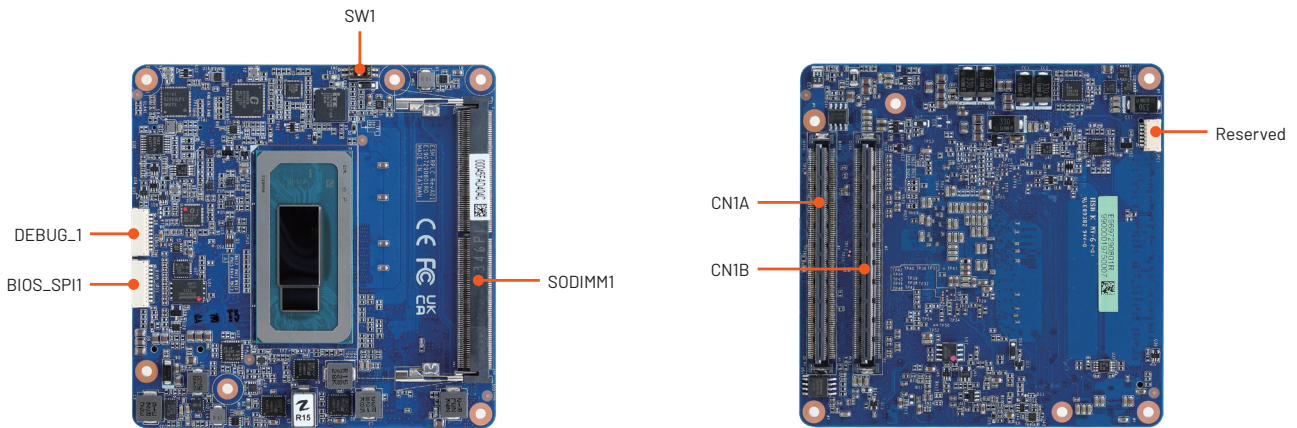

## Block Diagram

