

### Introduction

RS-232 Golden I/O series, a line of Multi-Port Serial Communication Card, is designed for both 3.3V / 5V and 32 / 64-bit PCI Bus with Plug and Play feature. It can be installed in virtually any available PC system and compatible with all major operating systems. Users do not need to manually set jumpers to configure I/O addresses and IRQ locations.

These cards offer independent serial ports for connecting terminals, modems, printers, scanners, cash registers, bar code readers, keypads, numeric displays, electrical scales, data acquisition equipment, and other serial devices for the PC and compatible systems. This board offers a reliable and high performance solution for serial multi-port communications.

Note: SUNIX High Speed RS-232 Card (H Version) supports ±15KV ESD protection for each signal and 921.6Kbps baud rate setting. Please refer to the User Manual - Product Family for details.

### 1. Hardware Installation



#### SAFETY FIRST

To avoid damages, please make sure to remove any power connection before card installation, and follow the detailed steps given below before inserting the card into your computer.

#### 1-1 PCI / PCIe Card

- Step 1: Turn your PC's power off, and shut off the power to any peripheral.
- Step 2: Remove the power plug from the plug socket.
- Step 3: Remove the cover from the computer case.
- Step 4: If fitted. Remove the metal cover plate on the rear of a free PCI/PCIe slot.
- Step 5: Insert I/O Control Board into the free PCI/PCIe slot and screw it firmly on the bracket side.
- Step 6: Place the cover back onto the computer.
- Step 7: Insert the plug into the plug socket.

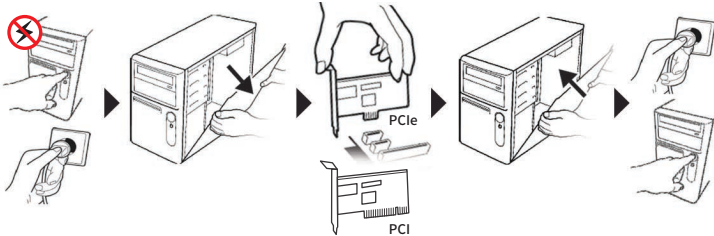

#### 1-2 Mini PCIe Card

- Step 1: Remove the screw attached to the motherboard.
- Step 2: Insert Mini PCIe Card tightly into the Mini PCIe slot.
- Step 3: Push the Mini PCIe Card down to the screw hole.
- Step 4: Lock screw on Mini PCIe Card that you remove from motherboard in step1.
- Step 5: Connect ribbon cable between Mini PCIe Card and extension board.
- Step 6: Secure the extension board to PC chassis.

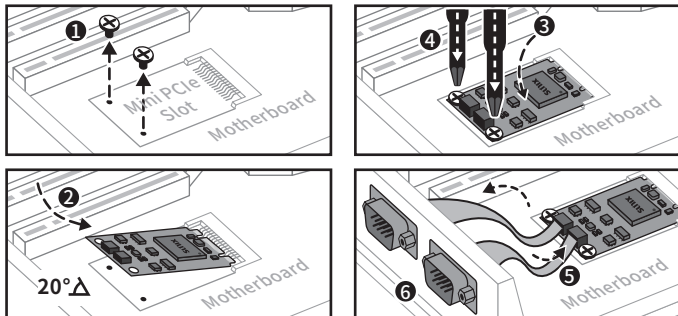

#### 1-3 M.2 Card (Take the M.2 2280 as an example)

- Step 1: Unfasten and remove the mounting screw from the motherboard.
- Step 2: Insert the M.2 card firmly into the slot at a 20° angle.
- Step 3: Press the M.2 card down until it aligns with the standoff/screw hole.
- Step 4: Secure the M.2 card using the screw removed in Step 1.
- Step 5: Connect the ribbon cable to interface the M.2 card with the extension board.
- Step 6: Mount and secure the extension board to the PC chassis.

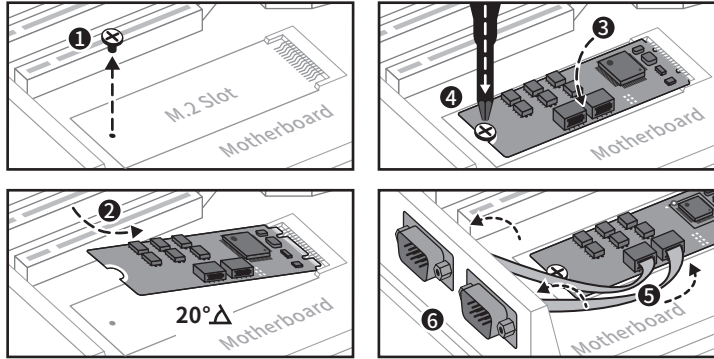

### 2. Pin Assignment

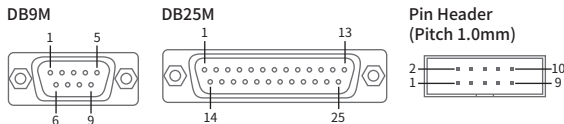

	PIN	DB9M	DB25M	Pin Header
DCD	1	8	1	
RxD	2	3	3	
TxD	3	2	5	
DTR	4	20	7	
GND	5	7	9	
DSR	6	6	2	
RTS	7	4	4	
CTS	8	5	6	
RI	9	22	8	

### 3. Driver Installation

- 1) You can download the latest driver from SUNIX official website (<https://www.sunix.com>)
- 2) Please plug the card into the available I/O slot
- 3) Unzip the software file and run setup.exe under Windows operating system.

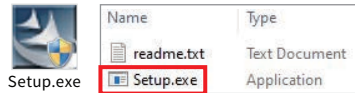

### 4. Hardware Verification

Please launch "Device Manager" to verify hardware installation correctly.  
**Controller Panel > All Control Panel Items > Device Manager**

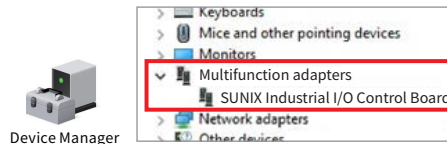

Device Manager

### 5. Configure Serial Interface

Under Serial interface catalog, select "COM" port item and you can read control panel as shown as below. If there are any settings changes, be sure to execute the "Apply" button to save the settings, or execute "Default" button to restore manufactory default settings.

#### (1) Serial Interface

Select this item to set Serial COM port settings.

#### (2) COM Port Control Panel

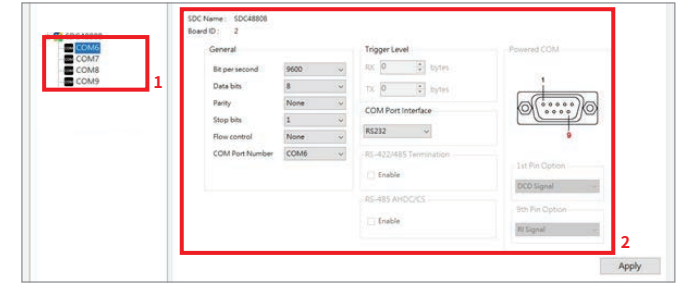

#### 5-1 COM Port Number Setting

Under Port Number, select a COM number to assign to the serial port. Click "Apply" to approve the settings for the selected port.  
 Note: In order to prevent system resource conflict, do not select "in use" port.

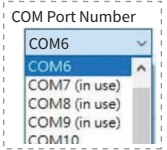

#### 5-2 COM I/O Resource

User can read the COM "IO Range" and "IRQ" located in system by selecting COM port. IRQ and I/O address is automatically assigned by the mainboard PCI BIOS automatically (before COM card driver installing). User can NOT assign legacy ISA address (3F8, 3E8, 2F8, 2E8) for the specific COM port. But for IRQ setting, user can set specific IRQ value for this PCI bus slot via mainboard's BIOS settings (not via driver). But all COM ports will share one IRQ value.

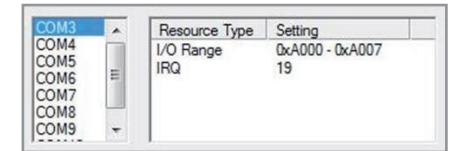

### 6. Troubleshooting

Q 1. System fails to find the Industrial I/O Control Board.

Ans: It may cause by following issue:

- a. The board is not properly plugged into the PCIe (M.2 / Mini PCIe) slot.
- b. Please clean the golden finger.
- c. The M.2 slot is defective. Please try other slots until you find one that works.
- d. The mainboard does not have an available IRQ for the PCIe (M.2 / Mini PCIe) board. Enter the PC's BIOS and make sure an IRQ setting is available in the PCI/PnP settings.
- e. The board itself might be defective. You can try another mainboard testing this board working or not.

Q 2. There is a blue screen when I entry operation system.

Ans: It may cause by following issue:

- a. The possible reason is an IRQ or I/O address conflict with other PCIe bus adapters, such as LAN or serial boards, or with the system BIOS. Refer to the corresponding problem in the previous FAQ for solutions.
- b. Please check driver update from your vendor.

Copyright - Copyright© 2026 SUNIX Co., Ltd. All Rights Reserved. No part of this publication may be reproduced, transcribed, stored in a retrieval system, translated into any language, or transmitted in any form or by any means, photocopying, manual, or otherwise, without prior written permission from SUNIX. Disclaimer - SUNIX shall not be liable for any incidental or consequential damages resulting from the performance or use of this equipment. SUNIX makes no representations or warranties regarding the contents of this manual. Information in this manual has been carefully checked for reliability; however, no guarantee is given as to the correctness of this content. In the interest of continued product improvement, this company reserves the right to revise the manual or include change in the specifications of the product described within it at any time without notice and without obligation to notify any person of such revision or changes. The information contained in this manual is provided for general use by the customers. Trademarks - SUNIX is a registered trademark of SUNIX Group. All other trademarks or registered marks in this manual belong to their respective owners. BSMI 聲明 - 限用物質含有情況標示資訊網站請參考下列網址: <http://www.sunix.com.tw> 操作說明: 選擇頁面之產品/型號/文件下載區(RoHS文件)