

SKY-MXM-5000A**MXM 3.1 Type B+ NVIDIA® Quadro® Embedded****5000 Ada with DP 1.4a****Startup Manual****Packing List**

Before you begin installing your card, please make sure that the following items have been shipped:

1. SKY-MXM-5000A GPU card x 1
2. China RoHS Doc x 1

If any of these items are missing or damaged, please contact your distributor or sales representative immediately.

Note: Acrobat Reader is required to view any PDF file. Acrobat Reader can be downloaded at: www.adobe.com/Products/acrobat/readstep2.html (Acrobat is a trademark of Adobe).

Graphics Options

The SKY-MXM-5000A supports 4 x DP 1.4, with display options port as shown below.

MXM Port	DP_A	DP_B	DP_C	DP_D
Advantech	Link A	Link C	Link D	Link E

Link	Display
Link A	DisplayPort (DP++)*, HDMI
Link B	Not supported
Link C	DisplayPort (DP++)*, HDMI
Link D	DisplayPort (DP++)*
Link E	DisplayPort (DP++)*

* Dual-mode DP (DP++) support requires one of the following external DP-AUX device when driving an external connector directly.

- DIODES PI3AUX221ZTAEX
- ANPEC APL3585

For more information on this and other Advantech products, please visit our website at:

<http://www.advantech.com>

For technical support and service, please visit our support website at:

<http://www.advantech.com/support>

This manual is for the SKY-MXM-5000A series Rev. A1.

Part No. 2041500000
Printed in China

1st Edition
June 2024

Standard Functions**Processor System**

- **GPU:** Quadro® 5000 Ada
- **Graphic architecture:** NVIDIA® Ada-Lovelace AD103-950
- **CUDA parallel-processing cores:** 9,728 CUDA® cores
- **RT cores:** 76
- **Tensor cores:** 304
- **GPU base/boost clock:** 1,425 MHz / 2,115 MHz
- **FP32 performance:** 41.15 TFLOPS
- **Bus:** MXM3.1, PCI Express Gen4 x 16 support
- **Max power consumption:** 115 W

Memory

- **Technology:** GDDR6 16GB memory
- **Interface width:** 256-bit
- **Bandwidth:** 576 GB/s
- **Memory ECC:** Supported

Physical

- **Dimensions:** 82(W) x 105(D) mm
- **Form factor:** MXM 3.1 Type B+

Environment

- **Operating:** 0 ~ 55° C
(Depend on CPU and cooler solution)
- **Non-operating:** -40° C ~ 85° C

Operating Systems

- **Microsoft:** Windows 10/11, 64-bit
- **Linux:** Linux Drivers, 64 bit
- **Software support:**
 - CUDA toolkit 11.8 and higher
 - CUDA compute version 8.9
 - Direct3D 12 Ultimate supporting feature level 12.2
 - Shader Model 8.9
 - OpenCL™ 3.0
 - OpenGL 4.6
 - Vulkan 1.3
- **Display port:** 4 x 1.4a

GPU Thermal Policy

GPU Core Clock throttles at temperatures(T_j) higher than those listed in below table, which lists the throttling temperature and behavior. Thermal throttling is necessary to ensure that the hottest temperature on the die does not exceed the sense temperature for prolonged periods of time.

Parameter	SKY-MXM-5000A	Units
Thermal Resistance (Junction to Case, RJC)	0.018	°C/W
Thermal Resistance (Junction to PCB Board, RJB)	0.987	°C/W
GPU Shutdown Temperature(OVERT)*	100	°C/W
GPU Slowdown Temperature (THERM_ALERT)**	97	°C
GPU Maximum Operating Temperature***	89	°C
GPU Target Temperature	87	°C

Notes:

* OVERT assertion results in an 87.5% (+8) hardware clock slowdown.

** THERM_ALERT assertion results in a 50%(+2) hardware clock slowdown.

*** The GPU maximum operating temperature is the maximum GPU temperature at which the GPU is guaranteed to operate at the target performance (Base Clock) under the total board power level.

Dimensions

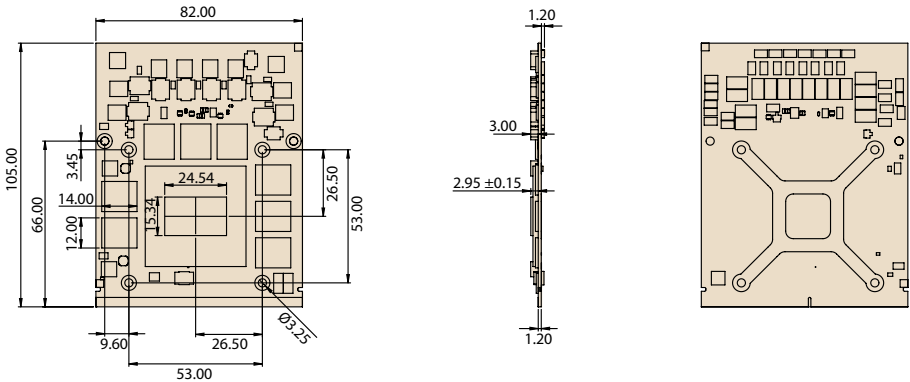

Block Diagram

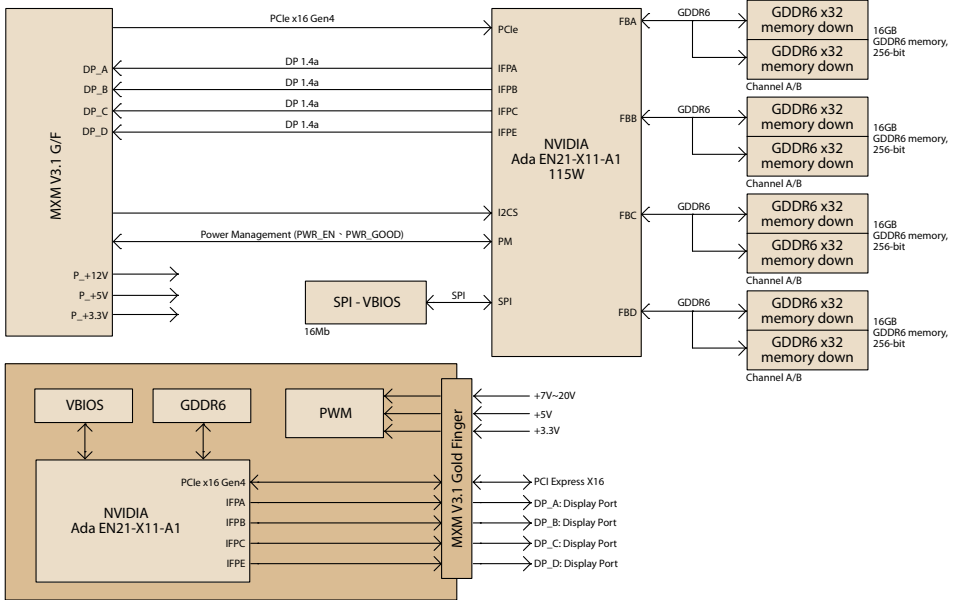

SKY-MXM-5000A Thermal info

Item	Tc	Units
1	85	°C
2	125	°C
3	125	°C
4	Refer to GPU Thermal Policy	-

