

User Manual

SKY-MXM-A2000

**MXM 3.1 Type-A NVIDIA®
Quadro® Embedded A2000 with
DP 1.4A**

ADVANTECH

Enabling an Intelligent Planet

Copyright

The documentation and the software included with this product are copyrighted 2023 by Advantech Co., Ltd. All rights are reserved. Advantech Co., Ltd. reserves the right to make improvements in the products described in this manual at any time without notice. No part of this manual may be reproduced, copied, translated, or transmitted in any form or by any means without the prior written permission of Advantech Co., Ltd. The information provided in this manual is intended to be accurate and reliable. However, Advantech Co., Ltd. assumes no responsibility for its use, nor for any infringements of the rights of third parties that may result from its use.

Acknowledgments

Quadro, RTX, and CUDA are trademarks of NVIDIA Corporation.

All other product names or trademarks are properties of their respective owners.

A Message to the Customer

Advantech Customer Service

Each and every Advantech product is built to the most exacting specifications to ensure reliable performance in the harsh and demanding conditions typical of industrial environments. Whether your new Advantech equipment is destined for the laboratory or the factory floor, you can be assured that your product will provide the reliability and ease of operation for which the name Advantech has come to be known.

Your satisfaction is our primary concern. Here is a guide to Advantech's customer services. To ensure you get the full benefit of our services, please follow the instructions below carefully.

Technical Support

We want you to get the maximum performance from your products. If you run into technical difficulties, we are here to help. For the most frequently asked questions, you can easily find answers in your product documentation. These answers are normally a lot more detailed than the ones we can give over the phone.

So please consult this manual first. If you still cannot find the answer, gather all the information or questions that apply to your problem, and with the product close at hand, call your dealer. Our dealers are well trained and ready to give you the support you need to get the most from your Advantech products. In fact, most problems reported are minor and are able to be easily solved over the phone.

In addition, free technical support is available from Advantech engineers every business day. We are always ready to give advice on application requirements or specific information on the installation and operation of any of our products.

Part No. 2001A20000

Printed in China

Edition 1

March 2023

Declaration of Conformity

FCC Class A

This equipment has been tested and found to comply with the limits for a Class A digital device, pursuant to part 15 of the FCC Rules. These limits are designed to provide reasonable protection against harmful interference in a residential installation. This equipment generates, uses, and can radiate radio frequency energy and, if not installed and used in accordance with the instruction manual, may cause harmful interference to radio communications. However, there is no guarantee that interference will not occur in a particular installation. If this equipment does cause harmful interference to radio or television reception, which can be determined by turning the equipment off and on, the user is encouraged to try to correct the interference by one or more of the following measures:

- Reorient or relocate the receiving antenna.
- Increase the separation between the equipment and receiver.
- Connect the equipment to an outlet on a circuit different from that to which the receiver is connected.
- Consult the dealer or an experienced radio/TV technician for assistance.

Product Warranty (2 years)

Advantech warrants the original purchaser that each of its products will be free from defects in materials and workmanship for two years from the date of purchase.

This warranty does not apply to any products that have been repaired or altered by persons other than repair personnel authorized by Advantech, or products that have been subject to misuse, abuse, accident, or improper installation. Advantech assumes no liability under the terms of this warranty as a consequence of such events.

Because of Advantech's high quality-control standards and rigorous testing, most customers never need to use our repair service. If an Advantech product is defective, it will be repaired or replaced free of charge during the warranty period. For out-of-warranty repairs, customers will be billed according to the cost of replacement materials, service time, and freight. Please consult your dealer for more details.

If you believe your product to be defective, follow the steps outlined below.

1. Collect all the information about the problem encountered. (For example, CPU speed, Advantech products used, other hardware and software used, etc.) Note anything abnormal and list any onscreen messages displayed when the problem occurs.
2. Call your dealer and describe the problem. Please have your manual, product, and any helpful information readily available.
3. If your product is diagnosed as defective, obtain a return merchandise authorization (RMA) number from your dealer. This allows us to process your return more quickly.
4. Carefully pack the defective product, a completed Repair and Replacement Order Card, and a proof of purchase date (such as a photocopy of your sales receipt) into a shippable container. Products returned without a proof of purchase date are not eligible for warranty service.
5. Write the RMA number clearly on the outside of the package and ship the package prepaid to your dealer.

Initial Inspection

Before you begin installing your MXM GPU card, please make sure that the following materials have been shipped:

- SKY-MXM-A2000 GPU card x 1
- China RoHS Document x 1

If any of these items are missing or damaged, contact your distributor or sales representative immediately. We have carefully inspected the SKY-MXM-A2000 mechanically and electrically before shipment. It should be free of marks and scratches and in perfect working order upon receipt. As you unpack the SKY-MXM-A2000, check it for signs of shipping damage. (For example, damaged box, scratches, dents, etc.) If it is damaged or it fails to meet the specifications, notify our service department or your local sales representative immediately. Also notify the carrier. Retain the shipping carton and packing material for inspection by the carrier. After inspection, we will make arrangements to repair or replace the unit.

Contents

Chapter 1 Hardware Configuration.....1

1.1	Introduction	2
1.2	Features	2
1.3	Specifications	2
1.3.1	Processor System	2
	Table 1.1: Processor System	2
1.3.2	Memory	2
	Table 1.2: Memory	2
1.3.3	Display Support and Options	3
	Table 1.3: Display Support and Options	3
1.3.4	Operating Systems	3
	Table 1.4: Operating Systems	3
1.3.5	Software Support	3
1.3.6	Graphics Options	3
1.3.7	Physical	3
1.3.8	Environment	3
1.4	Block Diagram	4
1.5	Board Dimensions	4
1.6	MXM 3.1 Connector Pin Definitions	5
1.7	Safety Precautions	7

Chapter 2 System Requirements.....9

2.1	Power Sequencing	10
	Figure 2.1 Power Sequencing	10
	Table 2.1: Signals Exempted	10
2.2	Input Voltage Requirements	10
2.3	Module Power Down and Power Up	11
	Figure 2.2 Power Sequencing	11
2.4	Reset Requirements	11
	Figure 2.3 Reset Sequencing	11
2.5	DisplayPort Interface	12
	Figure 2.4 Dual-Mode DisplayPort Implementation	12
2.6	DVI/HDMI on DP Interface	13
	Table 2.2: DisplayPort Multiplexed Signal Definitions	13
	Figure 2.5 Dual-Mode DisplayPort Implementation	13
2.7	Mechanical and Environmental Specifications	14
	Table 2.3: DVI-I DDC Mapping	14
2.8	GPU Thermal Policy	15
	Table 2.4: GPU Thermal Policy	15
2.9	System BIOS Requirements	15

Chapter 1

Hardware
Configuration

1.1 Introduction

As an NVIDIA Elite Partner, Advantech offers MXM GPU cards powered by NVIDIA's embedded GPUs. They are perfect for image processing and Edge AI acceleration in manufacturing, medical, and gaming industries. Built on NVIDIA's latest architectures, Advantech MXM GPUs deliver state-of-the-art technologies to provide high-performance computing and responsive capabilities to systems, as well as latency reduction, which is ideal for deployment in applications such as auto-optical inspection, driver-assistance, and surgical systems.

The Advantech SKY-MXM-A2000 MXM module is a high-performance MXM graphics module based on NVIDIA A2000 chipsets. The module is optimized for both performance and stability. It has 2560 CUDA cores, 4GB/8GB GDDR6, 8.25 TFLOPS Single-Precision Performance and supports 4 DisplayPort outputs. It is fast enough to handle professional CAD drawing applications, medical applications, and even image processing. Furthermore, the small form factor allows for easier system integration. The lower power requirement means it runs cool, which makes this module an ideal choice for an embedded solution with a need for high-end graphics capability.

1.2 Features

- NVIDIA® Quadro® A2000 with MXM 3.1 Type-A form factor (82 x 70 mm)
- Up to 2560 CUDA cores, 8.25 TFLOPS
- GDDR6 4GB/8GB memory, 128-bit, bandwidth 224 GB/s
- Up to 4 DisplayPort 1.4A outputs
- Long life cycle, supports 5+ years of availability

1.3 Specifications

1.3.1 Processor System

Table 1.1: Processor System	
GPU	Quadro® A2000
Graphics Architecture	NVIDIA® Ampere™ GA107-980-A1
CUDA Parallel-Processing Cores	2560 CUDA® cores
GPU Base/Boost Clock	1117 MHz / 1612 MHz
FP32 Performance	8.25 TFLOPS

1.3.2 Memory

Table 1.2: Memory	
Technology	GDDR6 4GB/8GB memory
Interface Width	128-bit
Bandwidth	224 GB/s
Max Clock	6000 MHz (4GB) / 7000 MHz (8GB)

1.3.3 Display Support and Options

Table 1.3: Display Support and Options	
DP	4 x DisplayPort 1.4A, 4K at 120Hz or 8K at 60Hz (Requires DSC) Supports HDMI 2.0 via DP dual-mode, 4K at 60 Hz

1.3.4 Operating Systems

Table 1.4: Operating Systems	
Microsoft	Windows 10/11 64-bit
Linux	Linux Drivers, 64-bit

1.3.5 Software Support

- CUDA Toolkit 8.0 and higher
- CUDA Compute Version 6.1 and higher
- OpenCL™ 1.2
- DirectX® 12
- OpenGL 4.5
- Vulkan 1.0

1.3.6 Graphics Options

The SKY-MXM-A2000 supports 4 x DP 1.4, with display ports as shown below.

MXM Port	DP_A	DP_B	DP_C	DP_D
Advantech	Link A	Link B	Link C	Link E

Link	Display
Link A	DisplayPort, DVI (Single Link or Dual Link With Link B)
Link B	DisplayPort, DVI (Dual Link with A)
Link C	DisplayPort, HDMI
Link E	DisplayPort, HDMI

1.3.7 Physical

- **Dimensions:** 82 (W) x 70 (D) mm
- **Form Factor:** MXM 3.1 Type-A

1.3.8 Environment

- **Operating Temperature:** 0 ~ 55 °C (Depending on CPU and cooler solution)
- **Non-Operating Temperature:** -40 °C ~ 85 °C

1.4 Block Diagram

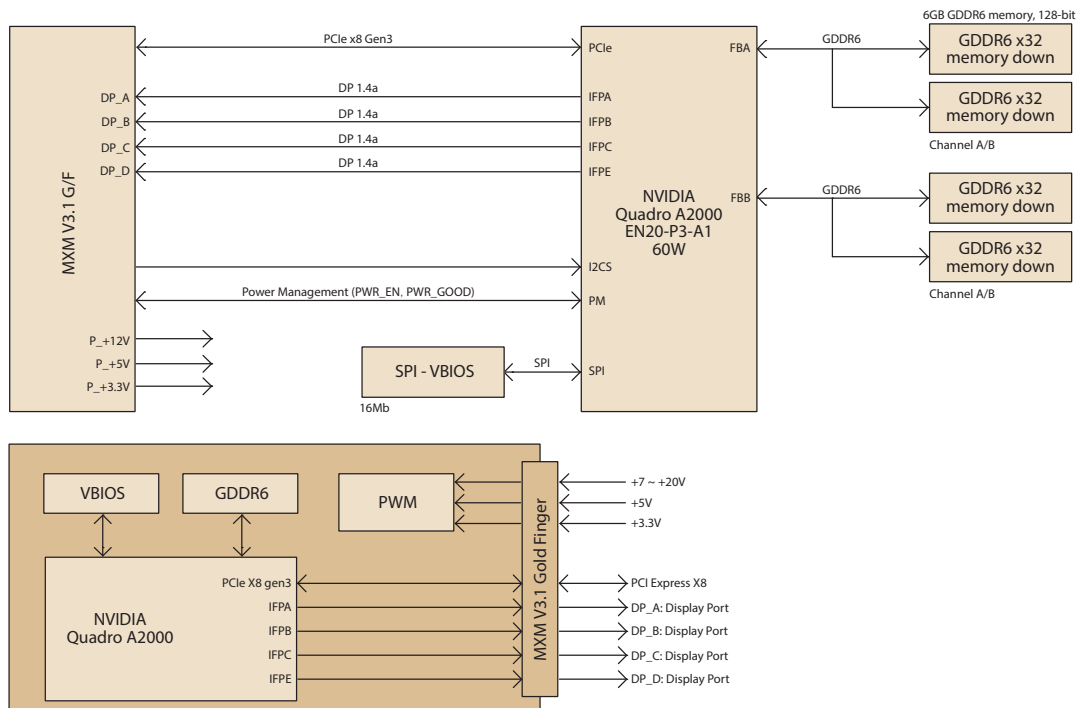

1.5 Board Dimensions

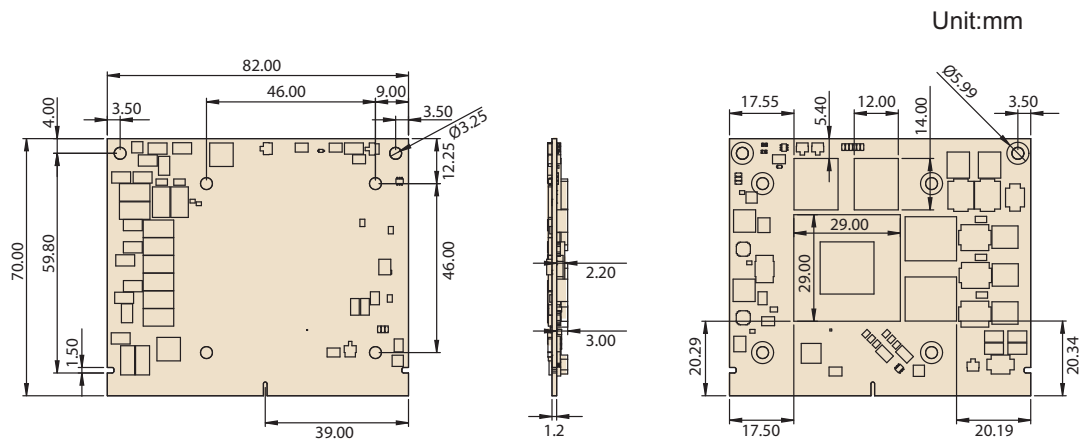

1.6 MXM 3.1 Connector Pin Definitions

Pin	Signal Name	Pin	Signal Name	Pin	Signal Name	Pin	Signal Name
E1	PWR_SRC	E2	PWR_SRC	141	PEX_RX1#	142	PEX_TX1#
E3	GND	E4	GND	143	PEX_RX1	144	PEX_TX1
1	5V	2	PRSNT_R#	145	GND	146	GND
3	5V	4	RSVD	147	PEX_RX0#	148	PEX_TX0#
5	5V	6	PWR_GOOD	149	PEX_RX0	150	PEX_TX0
7	5V	8	PWR_EN	151	GND	152	GND
9	5V	10	RSVD	153	PEX_REF-CLK#	154	PEX_CLK_REQ#
11	GND	12	GND	155	PEX_REFCLK	156	PEX_RST#
13	GND	14	RSVD	157	GND	158	RSVD
15	GND	16	RSVD	159	RSVD	160	RSVD
17	GND	18	RSVD	161	RSVD	162	RSVD
19	RSVD	20	TH_OVERT#	163	RSVD	164	RSVD
21	RSVD	22	TH_ALERT#	165	RSVD	166	GND
23	RSVD	24	RSVD	167	RSVD	168	RSVD
25	RSVD	26	RSVD	169	RSVD	170	RSVD
27	RSVD	28	RSVD	171	RSVD	172	RSVD
29	RSVD	30	RSVD	173	GND	174	GND
31	RSVD	32	SMB_DAT	175	RSVD	176	RSVD
33	RSVD	34	SMB_CLK	177	RSVD	178	RSVD
35	RSVD	36	GND	179	GND	180	GND
37	GND	38	RSVD	181	RSVD	182	RSVD
39	RSVD	40	RSVD	183	RSVD	184	RSVD
41	RSVD	42	RSVD	185	GND	186	GND
43	RSVD	44	RSVD	187	RSVD	188	RSVD
45	RSVD	46	GND	189	RSVD	190	RSVD
47	GND	48	PEX_TX15#	191	GND	192	GND
49	PEX_RX15#	50	PEX_TX15	193	RSVD	194	RSVD
51	PEX_RX15	52	GND	195	RSVD	196	RSVD
53	GND	54	PEX_TX14#	197	GND	198	GND
55	PEX_RX14#	56	PEX_TX14	199	DP_C_L0#	200	RSVD
57	PEX_RX14	58	GND	201	DP_C_L0	202	RSVD
59	GND	60	PEX_TX13#	203	GND	204	GND
61	PEX_RX13#	62	PEX_TX13	205	DP_C_L1#	206	DP_D_L0#
63	PEX_RX13	64	GND	207	DP_C_L1	208	DP_D_L0
65	GND	66	PEX_TX12#	209	GND	210	GND
67	PEX_RX12#	68	PEX_TX12	211	DP_C_L2#	212	DP_D_L1#
69	PEX_RX12	70	GND	213	DP_C_L2	214	DP_D_L1
71	GND	72	PEX_TX11#	215	GND	216	GND
73	PEX_RX11#	74	PEX_TX11	217	DP_C_L3#	218	DP_D_L2#
75	PEX_RX11	76	GND	219	DP_C_L3	220	DP_D_L2
77	GND	78	PEX_TX10#	221	GND	222	GND
79	PEX_RX10#	80	PEX_TX10	223	DP_C_AUX#	224	DP_D_L3#
81	PEX_RX10	82	GND	225	DP_C_AUX	226	DP_D_L3

83	GND	84	PEX_TX9#	227	RSVD	228	GND
85	PEX_RX9#	86	PEX_TX9	229	RSVD	230	DP_D_AUX#
87	PEX_RX9	88	GND	231	RSVD	232	DP_D_AUX
89	GND	90	PEX_TX8#	233	RSVD	234	DP_C_HPD
91	PEX_RX8#	92	PEX_TX8	235	RSVD	236	DP_D_HPD
93	PEX_RX8	94	GND	237	RSVD	238	RSVD
95	GND	96	PEX_TX7#	239	RSVD	240	3V3
97	PEX_RX7#	98	PEX_TX7	241	RSVD	242	3V3
99	PEX_RX7	100	GND	243	RSVD	244	GND
101	GND	102	PEX_TX6#	245	RSVD	246	DP_B_L0#
103	PEX_RX6#	104	PEX_TX6	247	RSVD	248	DP_B_L0
105	PEX_RX6	106	GND	249	RSVD	250	GND
107	GND	108	PEX_TX5#	251	GND	252	DP_B_L1#
109	PEX_RX5#	110	PEX_TX5	253	DP_A_L0#	254	DP_B_L1
111	PEX_RX5	112	GND	255	DP_A_L0	256	GND
113	GND	114	PEX_TX4#	257	GND	258	DP_B_L2#
115	PEX_RX4#	116	PEX_TX4	259	DP_A_L1#	260	DP_B_L2
117	PEX_RX4	118	GND	261	DP_A_L1	262	GND
119	GND	120	PEX_TX3#	263	GND	264	DP_B_L3#
121	PEX_RX3#	122	PEX_TX3	265	DP_A_L2#	266	DP_B_L3
123	PEX_RX3	124	GND	267	DP_A_L2	268	GND
125	GND	126	KEY	269	GND	270	DP_B_AUX#
127	KEY	128	KEY	271	DP_A_L3#	272	DP_B_AUX
129	KEY	130	KEY	273	DP_A_L3	274	DP_B_HPD
131	KEY	132	KEY	275	GND	276	DP_A_HPD
133	GND	134	GND	277	DP_A_AUX#	278	3V3
135	PEX_RX2#	136	PEX_TX2#	279	DP_A_AUX	280	3V3
137	PEX_RX2	138	PEX_TX2	281	PRSNT_L#	-	-
139	GND	140	GND				

1.7 Safety Precautions

Warning! *Always completely disconnect the power cord from your chassis whenever you work with the hardware. Do not make connections while the power is on. Sensitive electronic components can be damaged by sudden power surges. Only experienced electronics personnel should open the PC chassis.*



Caution! *Always ground yourself to remove any static charge before touching the MXM GPU card. Modern electronic devices are very sensitive to static-electric discharges. As a safety precaution, use a grounding wrist strap at all times. Place all electronic components on a static-dissipative surface or in a static-shielded bag when they are not in the chassis.*



Chapter 2

System Requirements

2.1 Power Sequencing

There is no power sequencing requirement for the input voltages to the MXM module. However the PWR_EN signal may be asserted only after all power rails are within specified tolerances. The state of PWR_GOOD is undefined until all rails are fully ramped. Refer to Figure 2.1 for details.

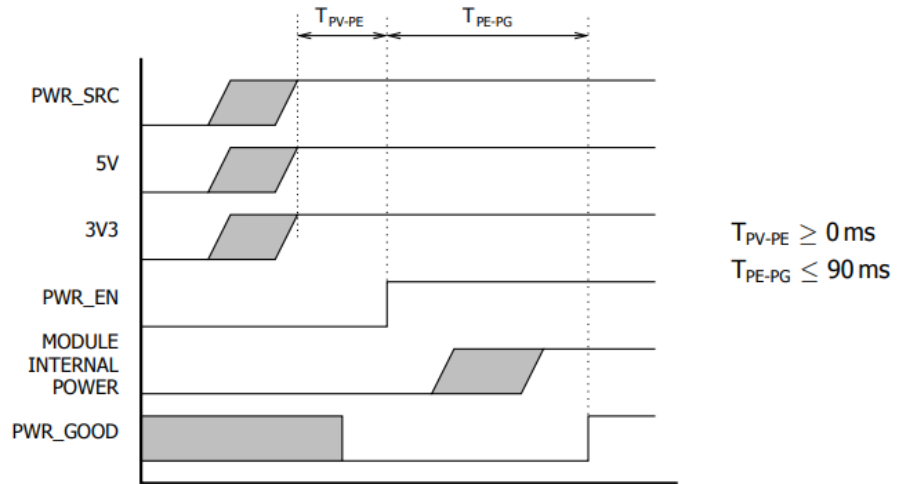

Figure 2.1 Power Sequencing

Table 2.1: Signals Exempted	
Group	Signals
Power and Thermal	SMB_CLK, SMB_DAT, TH_OVER#, TH_ALERT#, PWR_GOOD
System Management	WAKE#, PEX_CLK_REQ#
Display	DP_x_HPD, LVDS_x_HPD

Note! *No voltage shall be applied to any MXM module signal pin (except power pins and open drain signals specified in Table 2.1) until PWR_GOOD is asserted.*



2.2 Input Voltage Requirements

Input voltage to the GPU must strictly follow the ranges listed in the below table (with reference to GND).

Operating outside the required voltage range will cause permanent damage to the GPU

Power Rail	Min.	Typ.	Max.
PWR_SRC	6.5V	7-20V	22V
5V	4.7V	5V	5.3V
3V3	3.1V	3.3V	3.5V

2.3 Module Power Down and Power Up

The MXM module may be powered down using the PWR_EN signal. The system designer may choose to shut down or keep the input power while the module is powered down. Refer to Figure 2.2 for details.

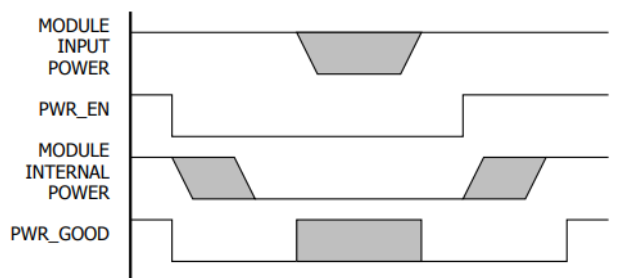

Figure 2.2 Power Sequencing

Note! All output signals from the MXM module are undefined when PWR_GOOD is deasserted or undefined. It is recommended that the system gate critical signals using an appropriate qualifier.



2.4 Reset Requirements

System reset may be deasserted only after the assertion of the PWR_GOOD signal. Figure 2.3 shows the reset requirements relative to the PWR_EN and PWR_GOOD signals. This sequence must be followed on initial power on, system reset, and resume from suspend/hibernate.

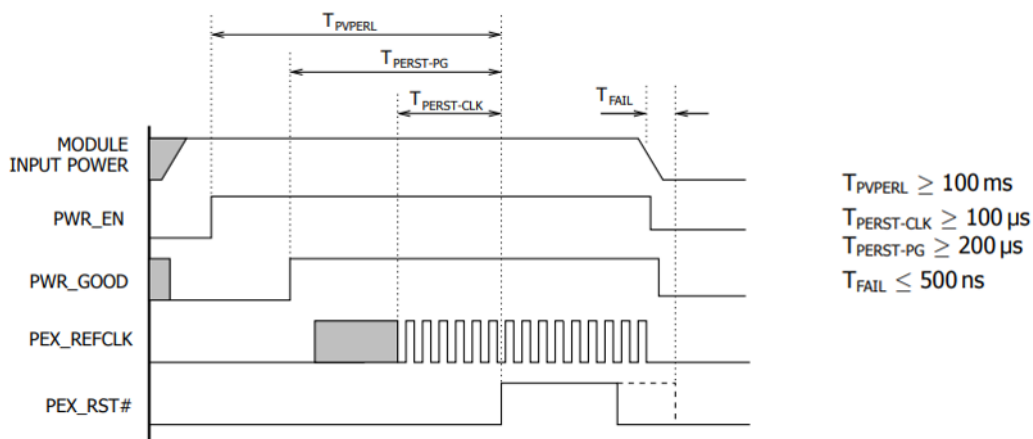

Figure 2.3 Reset Sequencing

Note! In order to reduce boot time, a system that monitors the PWR_GOOD signal is allowed to violate the TPVPERL specification as long as the TPERST-PG timing is still met.



2.5 DisplayPort Interface

DisplayPort traces must be routed with the impedance specified by Table 2.4. DC blocking capacitors must be placed on the system board. In addition the MXM implementation of Dual-mode DisplayPort requires the circuit in Figure 2.4 on the AUX lines for proper dongle detection. The HPD signal conditioning must also be placed on the system board.

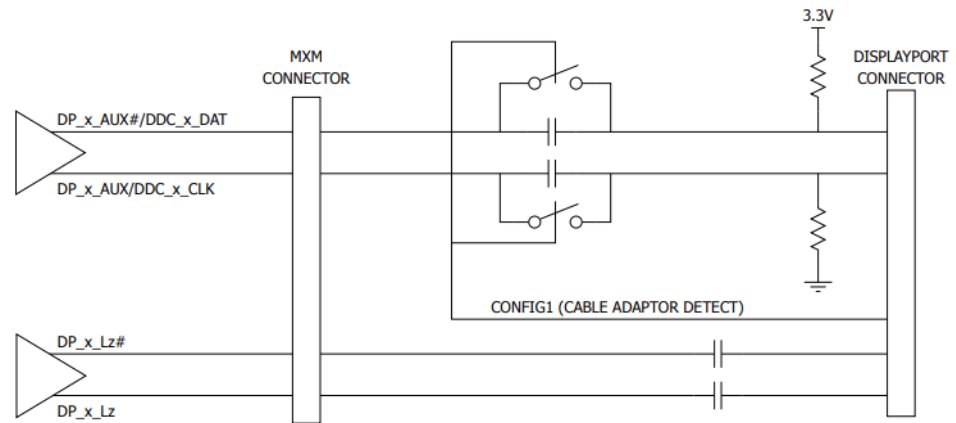

Figure 2.4 Dual-Mode DisplayPort Implementation

2.6 DVI/HDMI on DP Interface

Native DVI or HDMI connector support can be implemented using a DisplayPort interface. Additional circuitry is required on the system and the proper signal mapping must be observed. As Figure 2.5 shows, 499 Ω 1% pull-down resistors to ground on the DP lane signals must be placed on the connector side of the AC coupling capacitors gated by an FET to limit the leakage. Additionally, level shifting circuits must also be implemented on the DDC Data and Clock. Refer to the MXM Version 3.0 System Design Guide for specific details.

Table 2.2 shows the mapping to connect the signals from the MXM connector to the HDMI/DVI connector. For the optional dual-link DVI support refer to Table 2.3.

Table 2.2: DisplayPort Multiplexed Signal Definitions	
Pin Name	DVI/HDMI
DP_x_L0 DP_x_L0#	TX_x_D2 TX_x_D2#
DP_x_L1 DP_x_L1#	TX_x_D1 TX_x_D1#
DP_x_L2 DP_x_L2#	TX_x_D0 TX_x_D0#
DP_x_L3 DP_x_L3#	TX_x_CLK TX_x_CLK#
DP_x_AUX DP_x_AUX#	DDC_x_CLK DDC_x_DAT

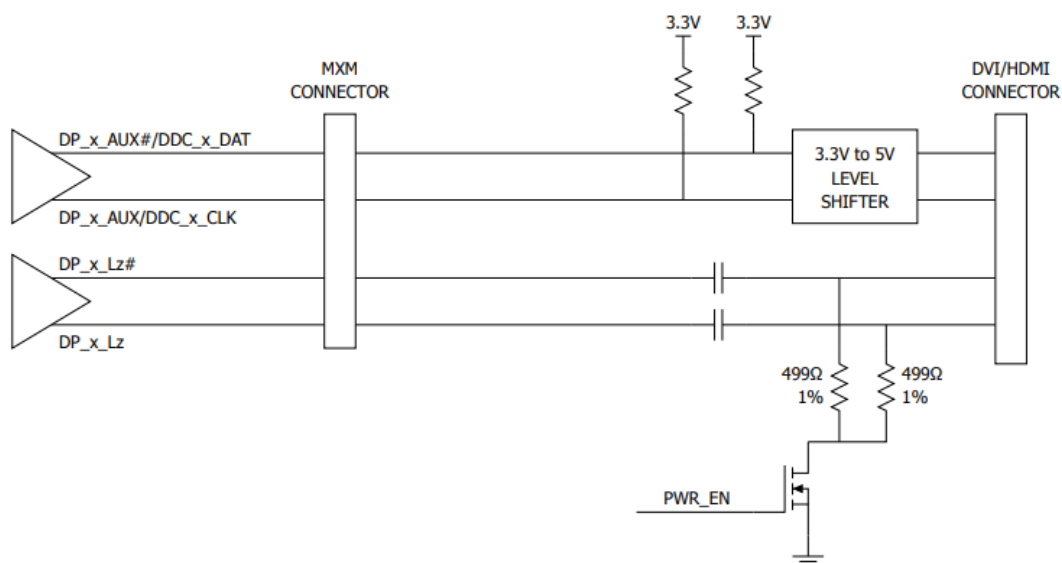

Figure 2.5 Dual-Mode DisplayPort Implementation

2.7 Mechanical and Environmental Specifications

Table 2.3 describes the mechanical characteristics of the packages.

Table 2.3: DVI-I DDC Mapping						
Symbol	Parameter	Min.	Nominal	Max.	Units	Notes
P_{cont}	Maximum allowable pressure during PCA, system assembly, and operation.	-	≤60	≤80 (die edge)	psi	1
T_{pkg}	Maximum allowable package temperature during device operation.	-		≤ TBD	°C	2
ϵ_{max}	Maximum allowable strain during PCA, system assembly, or operation.			≤ 500	μstrains	3

Note!



1. *This specification is based on the following conditions:*
 - a. *This specification is based on solder ball deformation and die chips and cracks. Additional requirements may be needed to meet the thermal performance and/or long-term reliability as to a specific application.*
 - b. *When a compliant thermal interface is used between die and heat sink, the bond line thickness must have less than 20% variation.*
 - c. *The pressure should be measured on the top of the die surface by an instrument equipped with pressure sensors. See details in “GPU Load Distribution Measurement Application Note”.*
 - d. *Nominal pressure is the total force divided by the die surface area. Since the pressure may have variations across all the surfaces, the following additional requirement is applied.*
 - i. *The pressure has to be measured from the top of the die surface with a grid resolution of 1x1 mm² for the pressure sensor.*
 - e. *Both the nominal and maximum pressure requirements must be met.*
2. *Maximum package temperature allowed. It includes device case and/or junction temperature.*
3. *Strain measurement shall follow IPC-9704, particularly on the following items:*
 - a. *The strain shall be measured on the top side of the PCB close to the four corners of the package. A rigid PCB is assumed.*
 - b. *For generic applications, the max. allowable strain must be no more than 500 μstrains for a board thickness from 1.0 to 3.2 mm. A separate requirement may be specified and the qualification test should be performed if:*
 - i. *A sensitive PCB laminate and buildup structure is used where the pad cratering occurs at a PCB strain of 500 μstrains or below.*
 - ii. *A weak surface finish on the PCB is used where a cracked solder joint has been observed at a PCB strain of 500 μstrains or below.*
 - iii. *The strain rate is too high (.5000 μstrains/second) during PCB operation.*
 - c. *For a PCB thickness of less than 1.0 mm, the max. allowable strain shall follow IPC 9704.*

2.8 GPU Thermal Policy

The GPU Core Clock throttles at temperatures (Tj) higher than those listed in the below table, which lists the throttling temperatures and behavior. Thermal throttling is necessary to ensure that the hottest temperature on the die does not exceed the sensed temperature for prolonged periods of time.

Table 2.4: GPU Thermal Policy		
Parameter	SKY-MXM-A2000 Sensed Temp.	Units
Thermal Resistance (Junction to Case, RJC)	0.039	°C/W
Thermal Resistance (Junction to PCB, RJB)	1.46	°C/W
GPU Shutdown Temperature (OVERT)*	100	°C
GPU Slowdown Temperature (THERM_ALERT)**	98	°C
GPU Maximum Operating Temperature***	89	°C
GPU Target Temperature	87	°C

Note! *OVERT assertion results in an 87.5% ($\div 8$) hardware clock slowdown.



**THERM_ALERT assertion results in a 50% ($\div 2$) hardware clock slowdown.

***The GPU maximum operating temperature is the maximum GPU temperature at which the GPU is guaranteed to operate at the target performance (Base Clock) under the total board power level.

2.9 System BIOS Requirements

Before you install the MXM module, please make sure your system BIOS is configured with the following settings:

1. CSM Support [Disabled]
2. Above 4G Decoding [Enabled]

ADVANTECH

Enabling an Intelligent Planet

www.advantech.com

Please verify specifications before quoting. This guide is intended for reference purposes only.

All product specifications are subject to change without notice.

No part of this publication may be reproduced in any form or by any means, such as electronically, by photocopying, recording, or otherwise, without prior written permission from the publisher.

All brand and product names are trademarks or registered trademarks of their respective companies.

© Advantech Co., Ltd. 2023