

3.5" SBC

Intel® Pentium® N4200 (2M Cache, up to 2.5 GHz)

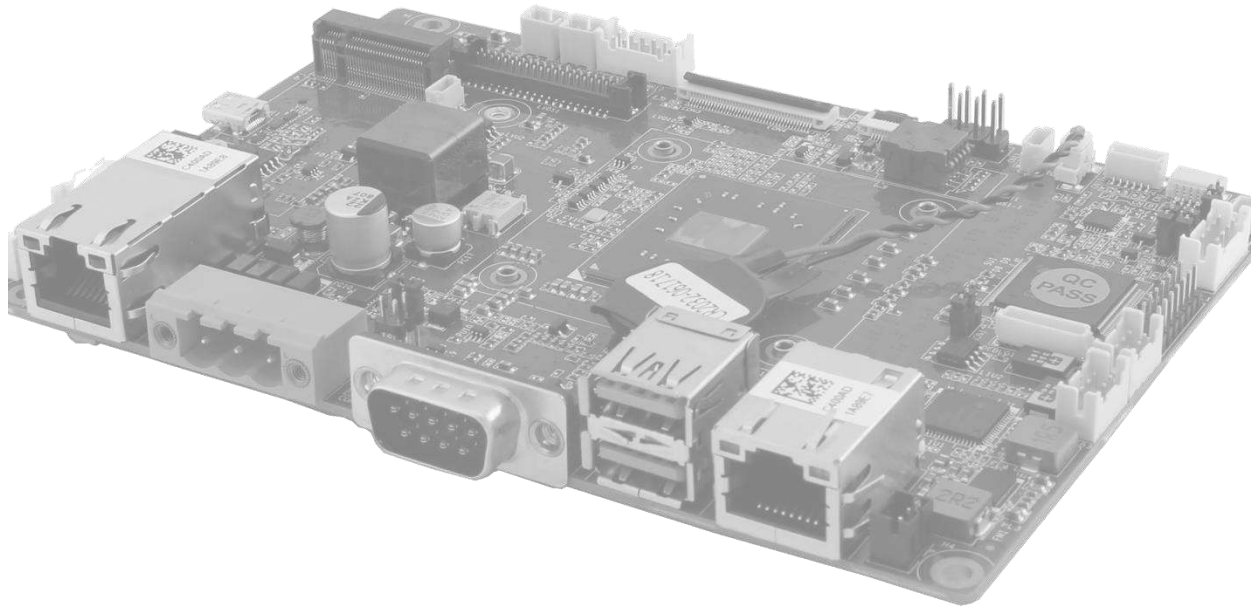

IP32S Version 2.0

User Manual

Contents

Preface	3
About This User Manual	5
Chapter 1: General Information	6
1.1 Introduction.....	7
1.2 Features	7
1.3 Hardware Specifications	8
1.4 Functional Description	9
1.5 Dimensions.....	10
Chapter 2: Hardware Installation	11
2.1 Motherboard Components	12
2.1.1 Key Component Location	12
2.2 Memory Module (SO-DIMM) Installation	13
2.3 I/O Equipment Installation	13
2.3.1 Power Input Jack	13
2.3.2 Serial COM Port.....	13
2.3.3 HDMI (Optional).....	13
2.3.4 Ethernet Interface	13
2.3.5 USB Port.....	14
2.3.6 Audio.....	14
2.4 Mainboard Connectors.....	14
2.4.1 Connectors	14
Chapter 3: Insyde H20 BIOS Setup	25
3.1 How and When to Use BIOS Setup	26
3.2 BIOS Functions.....	27
3.2.1 Main Menu	27
3.2.2 Advanced.....	28
3.2.3.Security.....	45
3.2.4 Power	46
3.2.5 Boot	49
3.2.6 Exit.....	51
3.3 Using Recovery Wizard to Restore Computer.....	53
3.4 How to Enable Watchdog.....	54
Chapter 4: Driver Installation	56
4.1 Chipset Driver.....	57
4.2 Graphics Driver.....	59
4.3 Audio Driver	61
4.4 LAN Driver	62
4.5 TXE Driver Installation	65
4.6 Watchdog Driver Installation	68
Chapter 5: Technical Support	72

5.1 Technical Support73
5.2 Drivers73
5.3 Software Development Kit (SDK).....73

Preface

Copyright Notice

No part of this document may be reproduced, copied, translated, or transmitted in any form or by any means, electronic or mechanical, for any purpose, without the prior written permission of the original manufacturer.

Trademark Acknowledgement

Brand and product names are trademarks or registered trademarks of their respective owners.

Disclaimer

We reserve the right to make changes, without notice, to any product, including circuits and/or software described or contained in this manual in order to improve design and/or performance. We assume no responsibility or liability for the use of the described product(s), conveys no license or title under any patent, copyright, or masks work rights to these products, and makes no representations or warranties that these products are free from patent, copyright, or mask work right infringement, unless otherwise specified. Applications that are described in this manual are for illustration purposes only. We make no representation or warranty that such application will be suitable for the specified use without further testing or modification.

Warranty

We warrant that each of its products will be free from material and workmanship defects for a period of one year from the invoice date. (Standard is one year, extended warranty will need to discuss with our sales representatives. If the customer discovers a defect, we will, at its option, repair or replace the defective product at no charge to the customer, provided it is returned during the warranty period of one year, with transportation charges prepaid. The returned product must be properly packaged in its original packaging to obtain warranty service.

If the serial number and the product shipping data differ by over 30 days, the in-warranty service will be made according to the shipping date. In the serial numbers the third and fourth two digits give the year of manufacture, and the fifth digit means the month (e. g., with A for October, B for November and C for December).

For example, the serial number 1W20Axxxxxxx means October of year 2020.

Packing List

Before using this Motherboard, please make sure that all the items listed below are present in your package:

- IP32S 3.5" SBC
- User Manual & Driver CD

If any of these items are missing or damaged, contact your distributor or sales representative immediately.

Customer Service

We provide a service guide as below for any problem by the following steps: First, contact your distributor, sales representative, or our customer service center for technical support if you need additional assistance.

You need to prepare the following information before you call:

- Product serial number
- Peripheral attachments
- Software (OS, version, application software, etc.)
- Detailed problem description
- The exact wording of any error messages

In addition, free technical support is available from our engineers every business day. We are always ready to give advice on application requirements or specific information on the installation and operation of any of our products. Please do not hesitate to call or e-mail us.

Advisory Conventions

Four types of advisories are used throughout the user manual to provide helpful information or to alert you to the potential for hardware damage or personal injury. These are Notes, Important, Cautions, and Warnings. The following is an example of each type of advisory.



Note:

A note is used to emphasize helpful information



Important:

An important note indicates information that is important for you to know.



Caution

A Caution alert indicates potential damage to hardware and explains how to avoid the potential problem.



Warning!

An Electrical Shock Warning indicates the potential harm from electrical hazards and how to avoid the potential problem.

Safety Precautions



Caution

Always ground yourself to remove any static charge before touching the CPU card. Modern electronic devices are very sensitive to static electric charges. As a safety precaution, use a grounding wrist strap at all times. Place all electronic components in a static-dissipative surface or static-shielded bag when they are not in the chassis.

Safety and Warranty

1. Please read these safety instructions carefully.
2. Please keep this user manual for later reference.
3. Please disconnect this equipment from any AC outlet before cleaning. Do not use liquid or spray detergents for cleaning. Use a damp cloth.
4. For pluggable equipment, the power outlet must be installed near the equipment and must be easily accessible.
5. Keep this equipment away from humidity.
6. Put this equipment on a reliable surface during installation. Dropping it or letting it fall could cause damage.
7. Make sure the voltage of the power source is correct before connecting the equipment to the power outlet.
8. Position the power cord so that people cannot step on it. Do not place anything over the power cord.
9. All cautions and warnings on the equipment should be noted.
10. If the equipment is not used for a long time, disconnect it from the power source to avoid damage by transient over-voltage.
11. If any of the following situations arises, get the equipment checked by service personnel:
 - a. The power cord or plug is damaged.
 - b. Liquid has penetrated into the equipment.
 - c. The equipment has been exposed to moisture.
 - d. The equipment does not work well, or you cannot get it to work according to the user's manual.

- e. The equipment has been dropped and damaged.
- f. The equipment has obvious signs of breakage.

About This User Manual

This User Manual provides information about using the 3.5" SBC IP32S Board version 2.0. It contains detailed description on how to use the motherboard, its components and features.



Note:

Some pictures in this guide are samples and can differ from actual product.

Chapter 1: General Information

This chapter includes the IP32S 3.5" SBC background information.

- 1.1 Introduction
- 1.2 Features
- 1.3 Motherboard Specifications
- 1.4 Functional Description
- 1.5 Physical Description

1.1 Introduction

Thank you for choosing Winmate's IP32S 3.5" SBC. The IP32S 3.5" SBC is powered by Intel® Pentium® N4200 Apollo Lake processor 1.10 GHz; up to 2.50 GHz with turbo boost technology and Intel® SOC chipset. The IP32S 3.5" SBC supports up to 8 GB of DDR3L SO-DIMM 1600 / 1866 MHz system memory. High performance platform delivers the performance and high scalability cutting-edge embedded computing application.

In terms of peripheral connectivity, the IP32S 3.5" SBC has two USB 3.0, one external RS232/422/485 serial port, and one Micro HDMI for video. IP32S 3.5" SBC supports two 2 x RJ-45 PCIe GbE one with PoE function on. Designed for industrial applications, the IP32S 3.5" SBC supports 12V DC power input.

Abundant I/O connectors and expandability makes IP32S 3.5" SBC to be the right fit in the majority of industrial and commercial applications such as machine vision and control, gaming, POS, KIOSK systems, industrial automation, and others. Powerful processor in a 3.5" form factor meets the demanding performance requirements of modern Industrial IoT and Edge Computing applications.

1.2 Features

IP32S 3.5" SBC features:

- 3.5-inch Form Factor (146 mm x 102 mm)
- Intel® Pentium® N4200 (2M Cache, up to 2.5 GHz)
- System memory DDR3L 1600 / 1866 MHz, SO-DIMM (up to 8 GB)
- Intel® HD Graphics 505
- 2 x 2.5 Gbps Ethernet Controller, one with PoE function on
- 2 x USB 3.0, 1 x RS232/422/485, 1 x Micro HDMI
- Operating temperature 0°C ~ 60°C
- Support M.2 2242 SSD 64GB(up to 512GB)

1.3 Hardware Specifications

Model Name	IP32S 3.5" SBC
System Specifications	
CPU	Intel® Pentium® N4200 (2M Cache, up to 2.5 GHz)
Chipset	Intel® SOC
System Memory	1 x DDR3L 1866 MHz SO-DIMM Slot, Max. 8 GB
BIOS	Insyde BIOS
Operating System	Windows 10 IoT Enterprise LTSC
Display Specifications	
Graphic	Intel® HD Graphics
LCD Interface	Dual-channel 18/24-bit LVDS Up to 1920 x 1200 @ 60Hz One Lane eDP.Up to 4096 x 2160 @60Hz
Audio	
Audio Codec	Realtek HD Audio Codec
Audio Interface	Line-in, Line-out, analog Mic- in
Ethernet	
LAN Controller	2 x Intel® Ethernet Controller
I/O Ports Specification	
External I/O	1 x Ethernet RJ45 Connector with PoE (LAN2) 1 x Ethernet RJ45 Connector (LAN1) 1 x USB3.0 Type-A (USB1) 1 x RS232/422/485, Default RS232 (COM1) 1 x Micro HDMI D Type (HDMI1) (Optional) 1 x 12V DC input, 3-Pin Terminal Block (J1)
Internal I/O	Power-input(J1) co-lay 2.5ψ DC Jack (DCJACK1) and 1x4 wafer (DC JACK2) 1 x SO-DIMM Slot (DIMM1) 2 x 2pin(1x2) for Speaker (CN2, CN3) 1 x Digital Mic-in (CN4) 1 x FPC connector for touch screen (CN8) 2 x 4pin(1x4) for LED light bar indicator (CN10, CN12) 1 x 6pin(1x6) for UART(CN11) 1 x 5pin(1x5) MCU debug port (CN15) 1 x 10pin(2x5) for RS232(CN16) 1 x 8pin(2x4) for SATA power (CN17) 1 x SATA III connector (SATA1) 1 x 7pin(1x7) for panel inverter (CON2) 1 x 40pin FPC connector Co-lay for LVDS (CON3) 1 x 40pin DF13 connector for LVDS(LVDS1) (Co-lay eDP Signal) 2 x 8pin(2x4) for 4 x USB 2.0 (USB2, USB3)
Internal I/O	1 x 12pin(2x6) for Line in/Line out/ Mic in(AUDIO1)

1.5 Dimensions

Board Dimensions (V200)

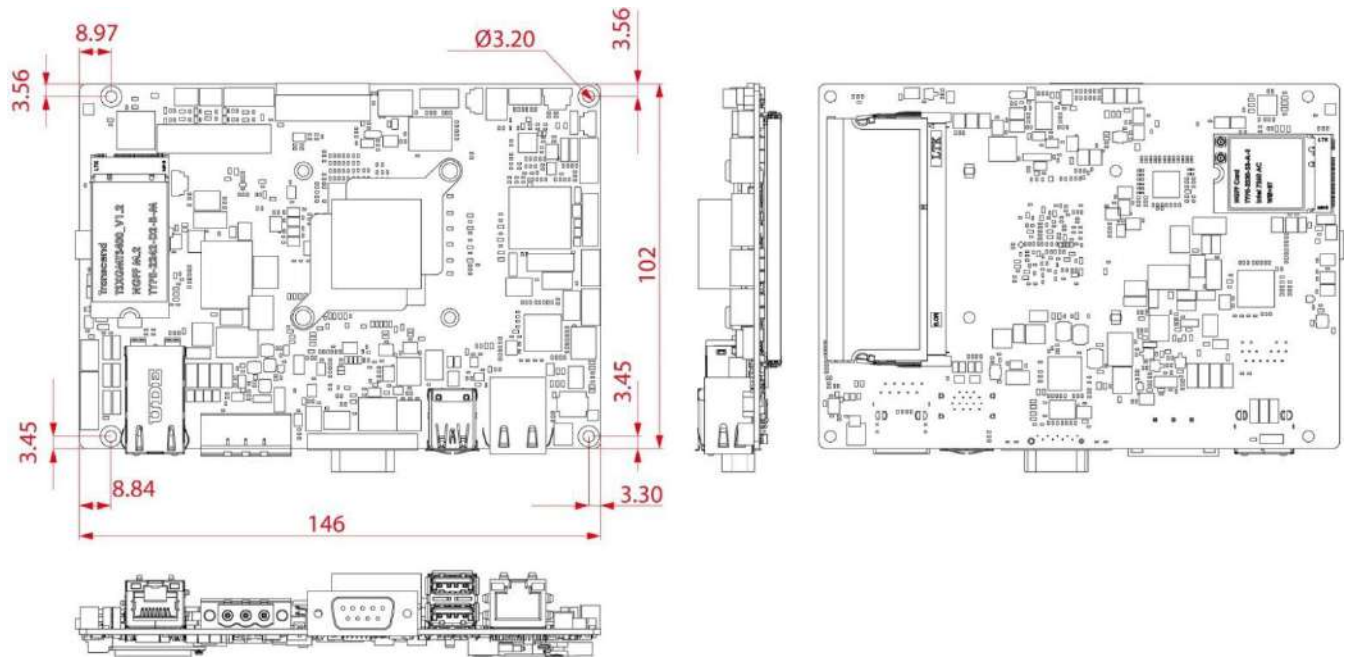

Chapter 2: Hardware Installation

This chapter provides information on how to use jumpers and connectors on the IP32S 3.5" SBC.

- 2.1 Motherboard Components
- 2.2 Memory Module Installation
- 2.3 I/O Equipment Installation
- 2.4 Jumper Settings
- 2.5 Motherboard Connectors

2.1 Motherboard Components

2.1.1 Key Component Location

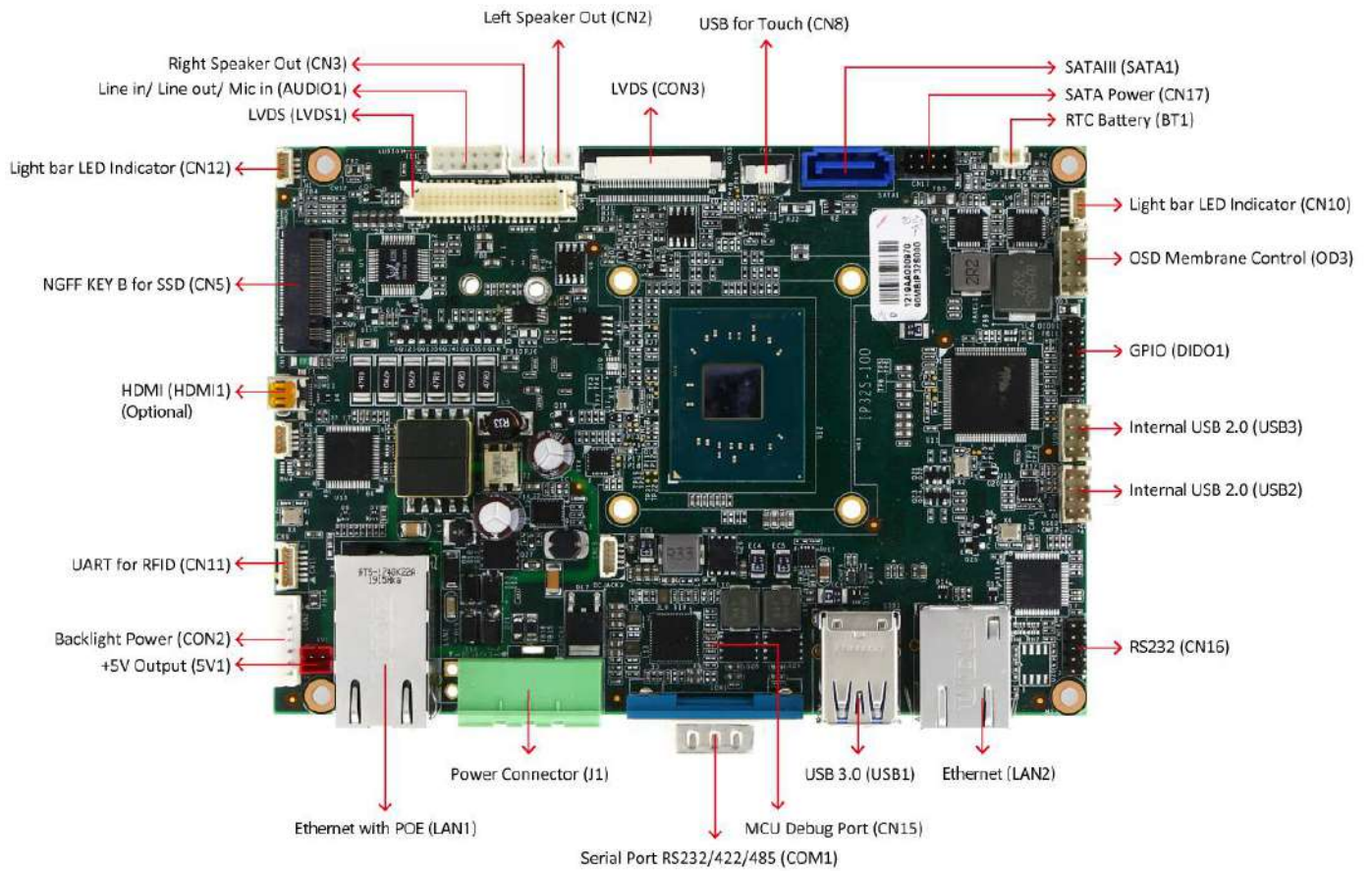

PCB Top Layer (Top View)

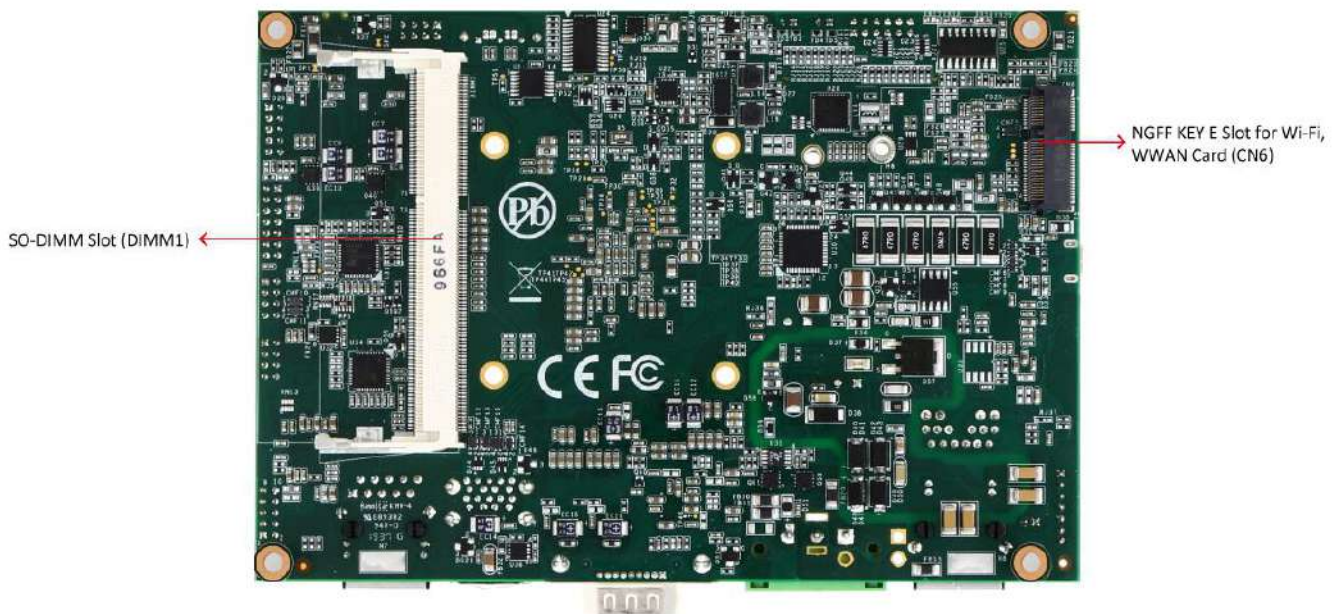

PCB Bottom Layer (Top View)

2.2 Memory Module (SO-DIMM) Installation

The IP32S 3.5" SBC has two 260-pin SO-DIMM slots. The socket supports DDR3L.

When installing the memory unit, please follow the steps below:

1. Firmly insert the SO-DIMM at an angle of about 30-degree into the slot. Align the SO-DIMM with the slot until it is fully inserted. The notch on the SO-DIMM should match the break on the slot.
2. Press downwards on SO-DIMM until the retaining clips at both ends fully snap closed and the SO-DIMM is properly seated.

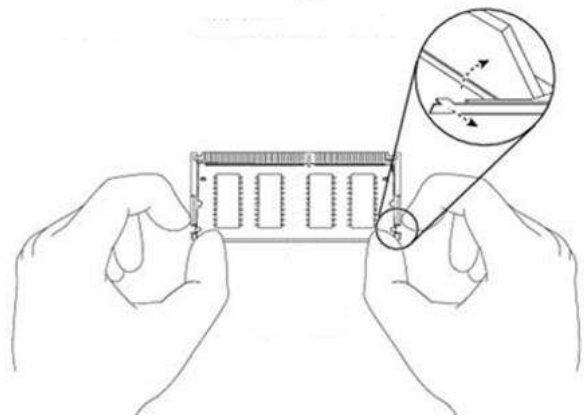

Note: Pull tabs away with your thumbs, bracing your forefingers against the rails. The memory module will be released. Then raise the memory module to a vertical position.



Caution The SO-DIMM only fits in one correct orientation. It will cause permanent damage to the development board and the SO-DIMM if the SO-DIMM is forced into the slot at the incorrect orientation.

2.3 I/O Equipment Installation

2.3.1 Power Input Jack

The IP32S 3.5" SBC allows plugging 12V DC jack on the board without another power module converter under power consumption by Intel® Pentium® N4200 (2M Cache, up to 2.5 GHz).

2.3.2 Serial COM Port

Two COM Port pin headers build in the motherboard. Optional COM ports support RS-422/485.

**When an optional touch-screen is ordered with panel PC, the serial com port can connect to a serial or an optional touch-screen.*

2.3.3 HDMI (Optional)

The IP32S 3.5" SBC has one Micro HDMI port that can be connected to an external LCD monitor. Use HDMI cable to connect to an external LCD monitor, and connect the power cable to the outlet. The HDMI connector is a 19-pin Micro HDMI connector.

2.3.4 Ethernet Interface

The IP32S 3.5" SBC is equipped with 2 x Intel® Ethernet Controller (PD 802.3at x1) which is supported for 2500BASE-T, 1000BASE-T and 100BASE-TX. It is supported by major network operating systems. The Ethernet ports provide two standard RJ-45 jacks, one of those supports PoE function.

2.3.5 USB Port

Eight USB devices (four with pin headers) may be connected to the system through an adapter cable. Various adapters may come with USB ports. USB usually connects the external system to the system. The USB ports support hot plug-in connection. Whatever, you should install the device driver before you use the device.

2.3.6 Audio

The High-Definition Audio channel capabilities are provided by a Realtek chipset supporting digital audio outputs. The audio interface includes two jacks: line-out and mic-in.

2.4 Mainboard Connectors

2.4.1 Connectors

The table below lists component side motherboard jumpers and connectors.

Connectors		
Label	Function	Note
J1	DC-In	3pin, phoenix connector
DCJACK1 (Co-lay J1)	DC-In	3pin, 2.5 ψ DC Jack
DCJACK2 (Co-lay J1)	DC-In	1x2 header, pitch 2.0mm
COM1	Serial Port RS-232/422/485	D-Sub9 (Male)
LAN1	Gigabit Ethernet	RJ45+LED
LAN2	Gigabit Ethernet with POE	RJ45+LED
USB1	USB 3.2 Gen1(5Gbps)	USB Type A
HDMI1	HDMI	Micro HDMI
DIMM1	SO-DIMM Slot	SO-DIMM
CN2	Left-Speaker out	1x2 wafer, pitch 2.0 mm
CN3	Right-Speaker out	1x2 wafer, pitch 2.0 mm
CN5	NGFF KEY B for SSD	NGFF KEY B Slot
CN6	NGFF KEY E Slot for Wi-Fi, WWAN Card	NGFF KEY E
CN8	USB for Touch	1x6 connector
CN10, CN12	Light bar LED indicator	1x4 wafer, pitch 2.0 mm
CN11	UART for RFID	1x6 wafer, pitch 2.0 mm
CN15	MCU Debug Port	1x5 wafer
CN16	RS232	2x5 header, pitch 2.0mm
CN17	SATA Power	2x4 wafer
SATA1	SATAIII	SATAIII connector
CON2	Backlight Power	1x7 wafer, pitch 2.0 mm
CON3	LVDS	For 10.1" panel
LVDS1	LVDS	2x20 wafer, pitch 1.25mm
USB2, USB3	Internal USB 2.0	2x4 wafer, pitch 2.0mm

Connectors

Label	Function	Note
AUDIO1	Line in/Line out/ Mic in	2x6 wafer, pitch 2.0mm
PANEL1	OSD Membrane Control	2x5 wafer, pitch 2.0mm
DIDO1	GPIO	2x7 wafer, pitch 2.0mm
5V1	+5V output	1x2 wafer, pitch 2.0 mm
BT1	RTC Battery	2P wafer, pitch 1.25 mm

2.4.1.1 J1: Power DC Jack

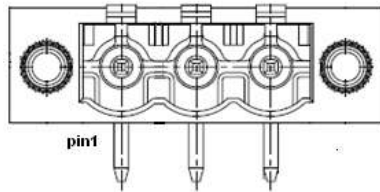

Pin №	Signal Name
1	Power
2	GND

2.4.1.2 DCJACK1: Power DC Jack

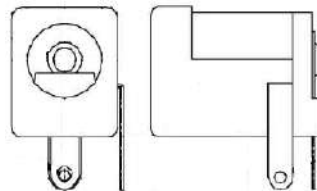

2.4.1.3 DCJACK2: Power DC Jack

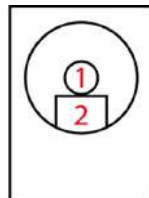

Pin №	Signal Name
1	Power
2	GND

2.4.1.4 COM1: Serial Port RS-232/422/485

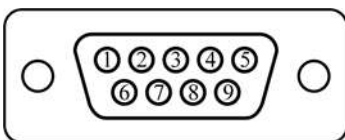

*Default setting: RS-232

Pin №	*RS-232	RS-422	RS-485
1	DCD	TxD-	D-
2	RXD	TxD+	D+
3	TXD	RxD+	NC
4	DTR	RxD-	NC
5	GND	GND	GND
6	DSR	NC	NC
7	RTS	NC	NC
8	CTS	NC	NC
9	RI	NC	NC

2.4.1.5 LAN1: Gigabit Ethernet

Pin №	Signal Name
1	MDI0+
2	MDI0-
3	MDI1+
4	MDI1-
5	MDI2+
6	MDI2-
7	MDI3+
8	MDI3-

2.4.1.6 LAN2: Gigabit Ethernet with PoE

Pin №	Signal Name
1	TRDT3
2	TRD3-
3	TRD3+
4	TRD2+
5	TRD2-
6	TRDT2
7	TRDT4
8	TRD4+
9	TRD4-
10	TRD1-
11	TRD1+
12	TRDT1
13	VC+
14	VC-
15	VC+
16	VC-

2.4.1.7 USB1: USB 3.0

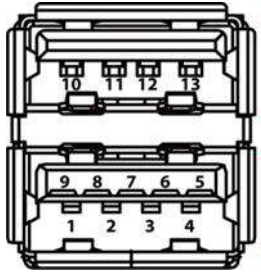

Pin №	Signal Name	Pin №	Signal Name
1	+5VUSB3.0	10	+5VUSB3.0
2	U2DN0	11	U2DN1
3	U2DP0	12	U2DP1
4	USB_GND	13	USB_GND
5	U3RXDN1	14	U3RXDN2
6	U3RXDP1	15	U3RXDP2
7	USB_GND	16	USB_GND
8	U3TXDN1	17	U3TXDN2
9	U3TXDP1	18	U3TXDP2

2.4.1.8 HDMI1: HDMI



Pin №	Signal Name	Pin №	Signal Name
1	HDMI_HPD1	11	HDMIB_TMDS0-
2	N/A	12	HDMIB_CLK+
3	HDMIB_TMDS2+	13	GND
4	GND	14	HDMIB_CLK-
5	HDMIB_TMDS2-	15	HDMI_CEC
6	HDMIB_TMDS1+	16	GND
7	GND	17	HDMI_DDC_CLK
8	HDMIB_TMDS1-	18	HDMI_DDC_DATA
9	HDMIB_TMDS0+	19	+V5S
10	GND		

2.4.1.9 DIMM1: SO-DIMM Slot

Standard SO-DIMM Slot.

2.4.1.10 CN2: Left-Speaker out

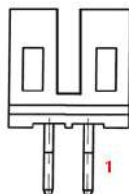

Pin №	Signal Name
1	OUT +
2	OUT -

2.4.1.11 CN3: Right-Speaker out

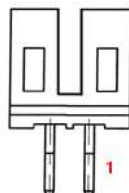

Pin №	Signal Name
1	OUT +
2	OUT -

2.4.1.12 CN5: NGFF KEY B for SSD

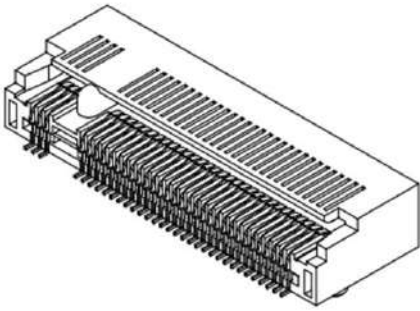

Pin №	Signal Name	Pin №	Signal Name
1	GND	2	+3.3V
3	GND	4	+3.3V
5	NC	6	NC
7	NC	8	NC
9	GND	10	NC
11	NC	12	KEY
13	KEY	14	KEY
15	KEY	16	KEY
17	KEY	18	KEY
19	KEY	20	NC
21	GND	22	NC
23	NC	24	NC
25	NC	26	NC
27	GND	28	NC
29	NC	30	NC
31	NC	32	NC
33	GND	34	NC
35	NC	36	NC
37	NC	38	SATA0_DEVSLP_R
39	GND	40	NC
41	NC	42	NC
43	NC	44	NC
45	GND	46	NC
47	NC	48	NC
49	NC	50	NC
51	GND	52	NC
53	NC	54	NC
55	NC	56	SMB_CLK_SSD
57	GND	58	SMB_DATA_SSD
59	NC	60	NC
61	NC	62	NC
63	NC	64	NC
65	NC	66	NC
67	NC	68	NC
69	GND	70	+3.3V
71	GND	72	+3.3V
73	GND	74	+3.3V
75	GND		

2.4.1.13 CN6: NGFF KEY E Slot for Wi-Fi, WWAN Card

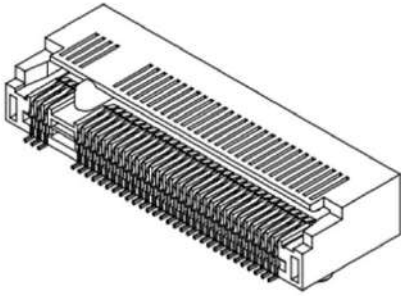

Pin №	Signal Name	Pin №	Signal Name
1	GND	2	+3.3V
3	USB+	4	+3.3V
5	USB-	6	NC
7	GND	8	NC
9	NC	10	NC
11	NC	12	NC
13	NC	14	NC
15	NC	16	NC
17	NC	18	GND
19	NC	20	NC
21	NC	22	NC
23	NC	24	KEY
25	KEY	26	KEY
27	KEY	28	KEY
29	KEY	30	KEY
31	KEY	32	NC
33	GND	34	NC
35	PCIE3_TXP1	36	NC
37	PCIE3_TXN1	38	NC
39	GND	40	NC
41	PCIE3_RXP1	42	NC
43	PCIE3_RXN1	44	NC
45	GND	46	NC
47	CLK_PCIE_SLOT3_P	48	NC
49	CLK_PCIE_SLOT3_N	50	NGFF_WIFI_SUSCLK
51	GND	52	WIFI_RST#
53	CLKREQ_WIFI#	54	BT_EN
55	PCIE_WAKE#	56	WIFI_EN_R
57	GND	58	SMB_DATA_WIFI
59	NC	60	SMB_CLK_WIFI
61	NC	62	NC
63	GND	64	NC
65	NC	66	NC
67	NC	68	NC
69	GND	70	NC
71	NC	72	+3.3V
73	NC	74	+3.3V
75	GND		

2.4.1.14 CN8: USB for Touch 10.1”

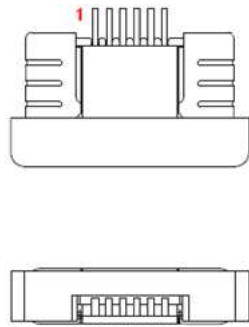

Pin №	Signal Name
1	NC
2	Ground_N3
3	D+
4	D-
5	Ground_P3
6	VCC (5V)

2.4.1.15 CN10, CN12: Light Bar LED Indicator

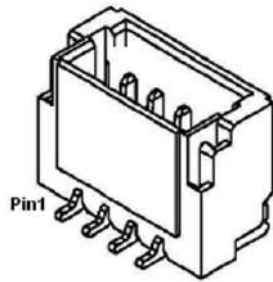

Pin №	Signal Name
1	VCC (5V)
2	Red LED
3	Green LED
4	Blue LED

2.4.1.16 CN11: UART for RFID

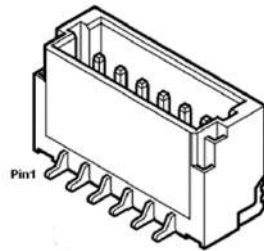

Pin №	Signal Name
1	TXD
2	RXD
3	NC
4	Ground
5	VDD
6	NC

2.4.1.17 CN16: RS232

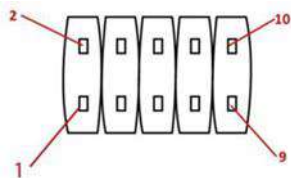

Pin №	Signal Name	Pin №	Signal Name
1	DCD	2	DSR
3	RXD	4	RTS
5	TXD	6	CTS
7	DTR	8	RI
9	GND	10	IO_PWR

2.4.1.18 CN17 : SATA Power

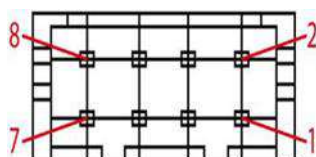

Pin №	Signal Name	Pin №	Signal Name
1	+12V	2	+12V
3	GND	4	GND
5	GND	6	GND
7	+5V	8	+5V

2.4.1.19 SATA1: SATAIII

Standard SATAIII

2.4.1.20 CON2: Backlight Power

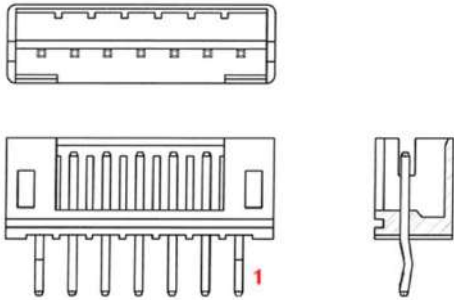

Pin №	Signal Name
1	12V or 5V
2	12V or 5V
3	12V or 5V
4	Ground
5	Control Pin
6	Ground
7	BLON

2.4.1.21 CON3: LVDS

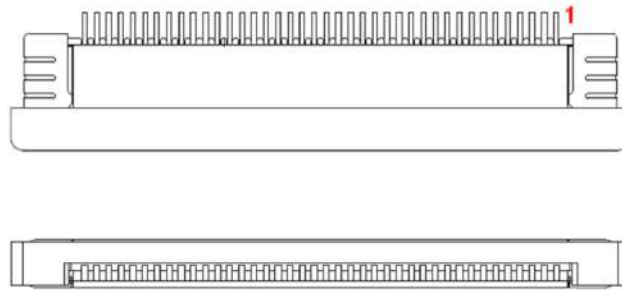

Pin №	Signal Name	Pin №	Signal Name
1	VDD	21	TXO3+
2	VDD	22	GND
3	VDD	23	TXE3+
4	VDD	24	TXE3-
5	NC	25	TXE_CLK+
6	NC	26	TXE_CLK-
7	GND	27	GND
8	TXO0-	28	TXE2+
9	TXO0+	29	TXE2-
10	GND	30	TXE1+
11	TXO1-	31	TXE1-
12	TXO1+	32	GND -
13	GND	33	TXE0+
14	TXO2-	34	TXE0-
15	TXO2+	35	GND
16	GND	36	Backlight Enable
17	TXO_CLK-	37	Backlight Control
18	TXO_CLK+	38	Backlight Power
19	GND	39	Backlight Power
20	TXO3-	40	Backlight Power

2.4.1.22 LVDS1: LVDS/eDP

(Yellow highlight is HW BOM Option)

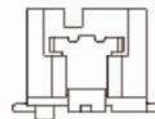
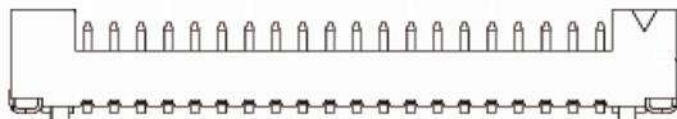
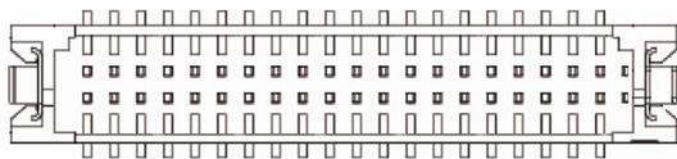

Pin №	Signal Name	Pin №	Signal Name
1	LCDVDD	2	TXOUT_L0- / AUX_N
3	LCDVDD	4	TXOUT_L0+ / AUX_P
5	LCDVDD	6	TXOUT_L1-
7	GND	8	TXOUT_L1+
9	GND	10	TXOUT_L2- / LANE0+
11	GND	12	TXOUT_L2+ / LANE0-
13	GND	14	TXCLK_L-
15	GND	16	TXCLK_L+
17	GND	18	TXOUT_L3- / LANE1+
19	GND	20	TXOUT_L3+ / LANE1-
21	GND	22	TXOUT_U0-
23	GND	24	TXOUT_U0+ / DP_HPD
25	GND	26	TXOUT_U1-
27	GND	28	TXOUT_U1+
29	GND	30	TXOUT_U2-
31	GND	32	TXOUT_U2+
33	GND	34	TXCLK_U-
35	GND	36	TXCLK_U+
37	GND	38	TXOUT_U3-
39	GND	40	TXOUT_U3+

2.4.1.23 USB2, USB3 : Internal USB 2.0

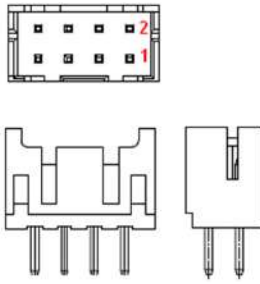

Pin №	Signal Name	Pin №	Signal Name
1	USBVCC	2	USBVCC
3	USB_N3	4	USB_N2
5	USB_P3	6	USB_P2
7	GND	8	GND

2.4.1.24 AUDIO1: Line in/Line out/ Mic in

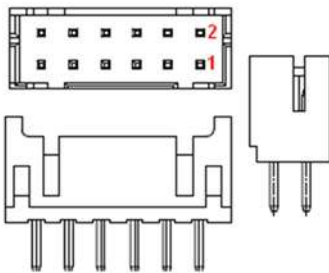

Pin №	Signal Name	Pin №	Signal Name
1	AZ_FOUT_R	2	AZ_FOUT_L
3	+V5S	4	AUGND
5	LINE1_R	6	LINE1_L
7	MIC1_R	8	MIC1_L
9	AUGND	10	Font_SENSE
11	Mic_SENSE	12	Line_SENSE

2.4.1.25 OD3: OSD Membrane Control

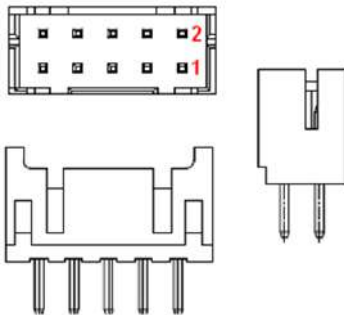

Pin №	Signal Name	Pin №	Signal Name
1	+V5S	2	+V3.3S
3	GND	4	-HDD_LED
5	PWRBTN#	6	GND
7	GND / ADJ+	8	RESETBTN#
9	N/C / ADJ-	10	+V5A

2.4.1.26 DIDO1: GPIO

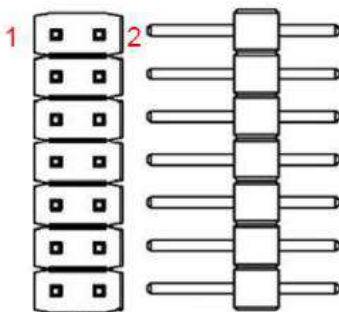

Pin №	Signal Name	Pin №	Signal Name
1	GND	2	+V5A
3	DOUT3	4	DOUT1
5	DOUT2	6	DOUT0
7	DINT3	8	DINT1
9	DINT2	10	DINT0
11	GPIO53_IN0	12	GPIO56_OUT0
13	GPIO54_IN1	14	GPIO57_OUT1

2.4.1.27 5V1: +5V Output

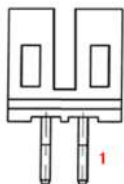

Pin №	Signal Name
1	5V
2	Ground

2.4.1.28 BT1: RTC Battery

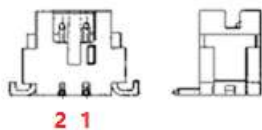

Pin №	Signal Name
1	3.3V
2	GND

Chapter 3: Insyde H20 BIOS Setup

This chapter describes the different settings available in the INSYDE BIOS that comes with the board. This chapter offers information on the Award BIOS installation utility.

- 4.1 How and When to Use BIOS Setup
- 4.2 BIOS Functions
- 4.3 Using Recovery Wizard to Restore Computer
- 4.4 How to Enable Watchdog

3.1 How and When to Use BIOS Setup

To enter the BIOS setup, you need to connect an external USB keyboard, external monitor and press Del key when the prompt appears on the screen during start up. The prompt screen shows only few seconds so need press Del key quickly.



Important: Updated BIOS version may be published after the manual released. Check the latest version of BIOS on the website.

You may need to run BIOS setup utility for reasons listed below:

1. Error message on screen indicates to check BIOS setup
2. Restoring the factory default settings.
3. Modifying the specific hardware specifications
4. Necessity to optimize specifications

BIOS Navigation Keys

The following keys are enabled during POST:

Key	Function
Del	Enters the BIOS setup menu.
F7	Display the boot menu. Lists all bootable devices that are connected to the system. With cursor ↑ and cursor ↓ and by pressing <ENTER>, select the device used for the boot.
Pause	Pressing the [Pause] key stops the POST. Press any other key to resume the POST.

The following Keys can be used after entering the BIOS Setup.

Key	Function
F1	Help
F5/ F6	Change Values
F9	Setup Defaults
F10	Save & Exit
Esc	Exit
Enter	Select SubMenu
↑/ ↓	Select Item
← / →	Select Item

For items marked ► press <Enter> for more options.



Note:

You can press the F1, F2, F3, F4, -/+, and Esc keys by connecting a USB keyboard to your computer.

3.2 BIOS Functions

3.2.1 Main Menu

The Main menu displays the basic information about your system including BIOS version, processor RC version, system language, time, and date.

When you enter BIOS setup, the first menu that appears on the screen is the main menu. It contains the system information including BIOS version, processor RC version, system language, time, and date.

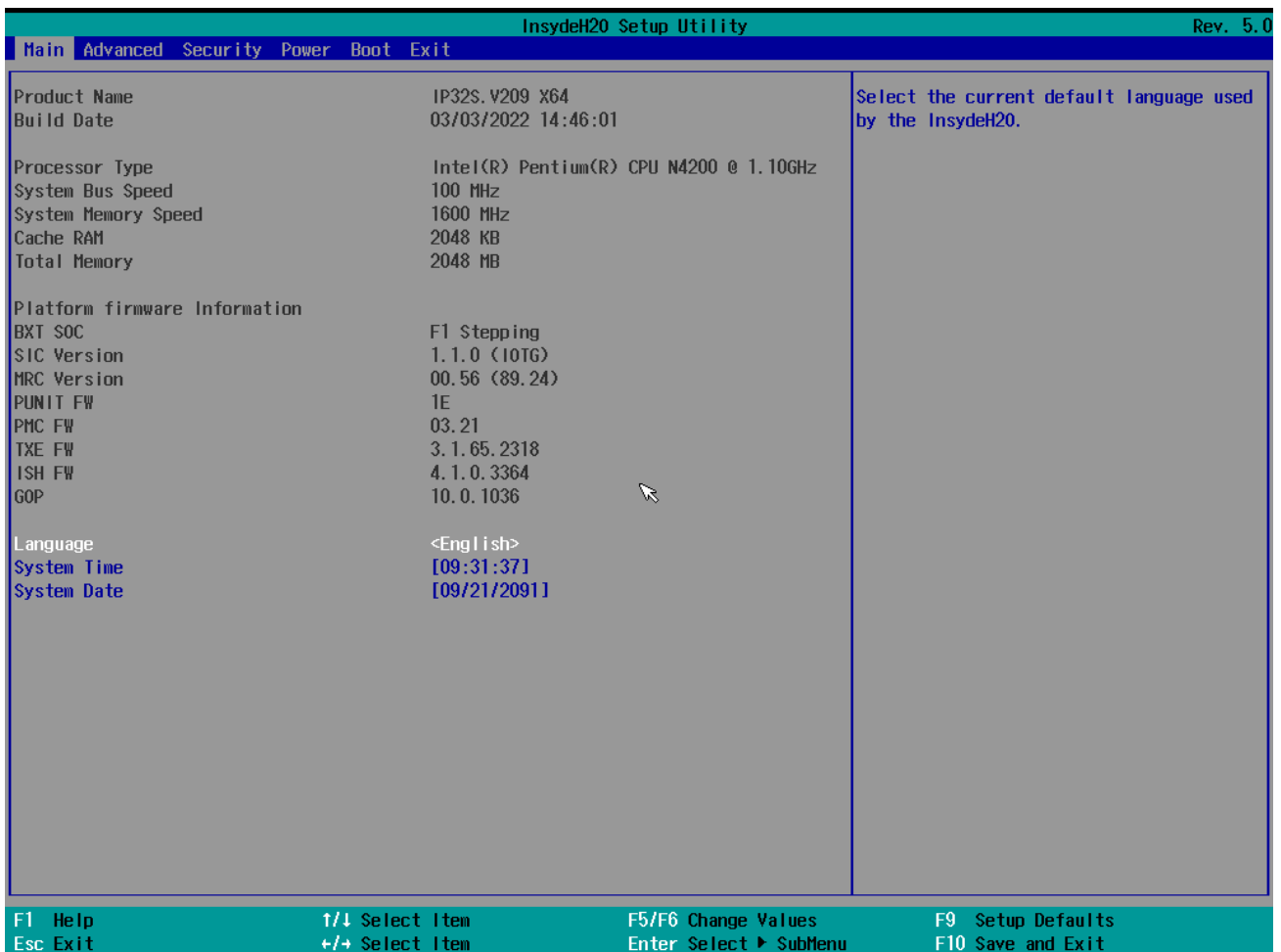

BIOS Setting	Description	Setting Option	Effect
Language	Displays the system language. [English] is set up by default.	Adjustment of the language	Set the language in other language. The language in this device is English.
System Time	This is current time setting. The time is maintained by the battery when the device is turned off.	Date and time changes.	Set the time in the format: [hh/mm/ss]
System Date	This is current date setting.	Date and time changes.	Set the date in the format [mm/dd/yyyy];

3.2.2 Advanced

Select the Advanced Tab from the setup menu to enter the advanced BIOS setup screen. You can select any of the items on the left frame of the screen to go to the sub menu for the item, such as CPU Configuration. You can use the <Arrow> keys enter all advanced BIOS setup options. The advanced BIOS setup menu is shown below. The submenus described on the following pages.



Caution

Handle advanced BIOS settings page with caution. Any changes can affect the operation of your computer.

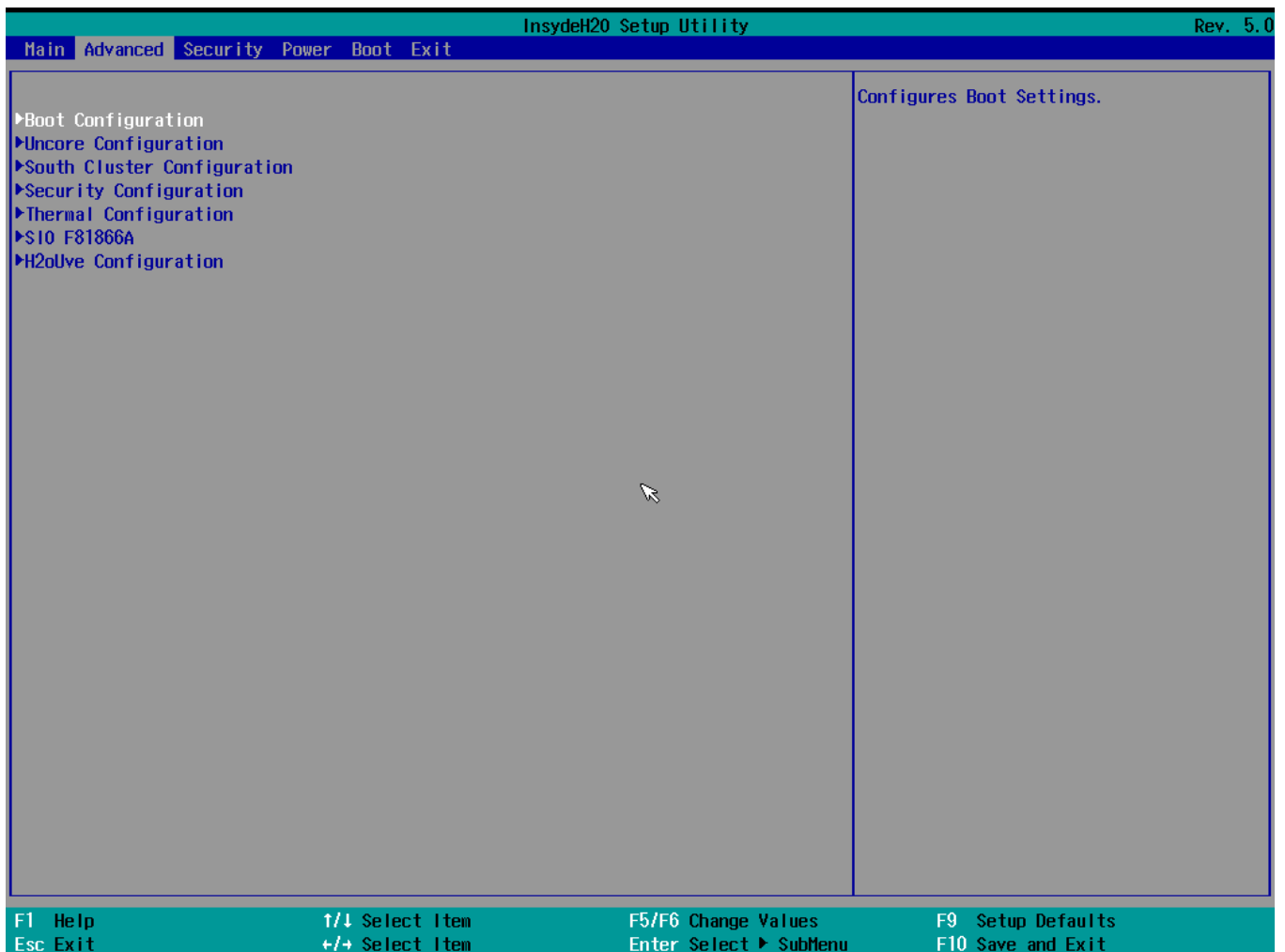

BIOS Setting	Description	Setting Option	Effect
Boot Configuration	Configures Boot setting.	Enter	Opens submenu
Uncore Configuration	Configures Uncore setting.	Enter	Opens submenu
South Cluster Configuration	Configures South Cluster setting.	Enter	Opens submenu
Security Configuration	Configures Security setting.	Enter	Opens submenu
Thermal Configuration	Configures Thermal setting.	Enter	Opens submenu
SIO F81866A	Configures SIO F81866A setting.	Enter	Opens submenu
H2OuVe Configuration	Configures H2OuVe setting.	Enter	Opens submenu

3.2.2.1 Boot Configuration

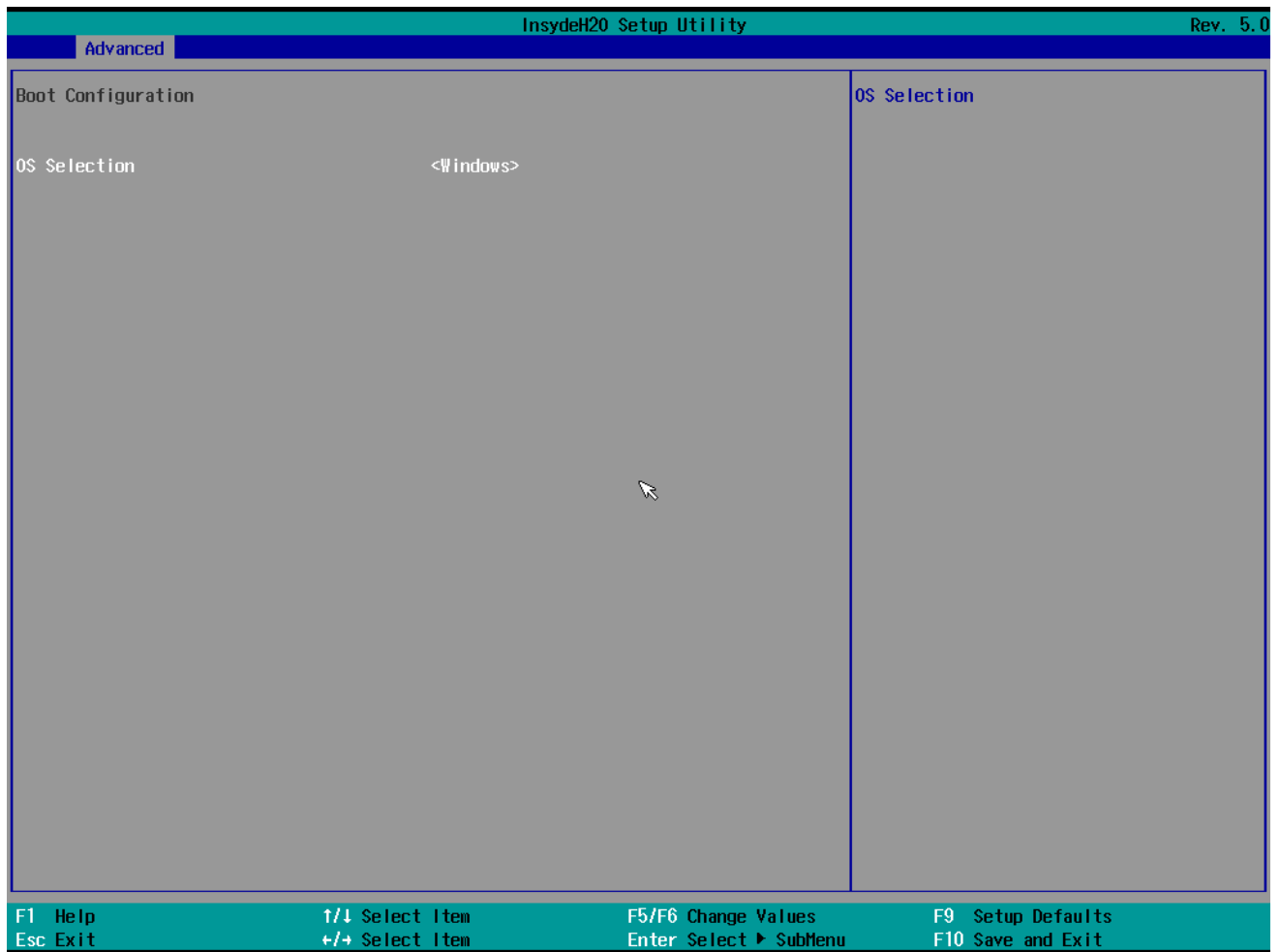

BIOS Setting	Description	Setting Option	Effect
OS Selection	OS Selection	Enter	Opens submenu

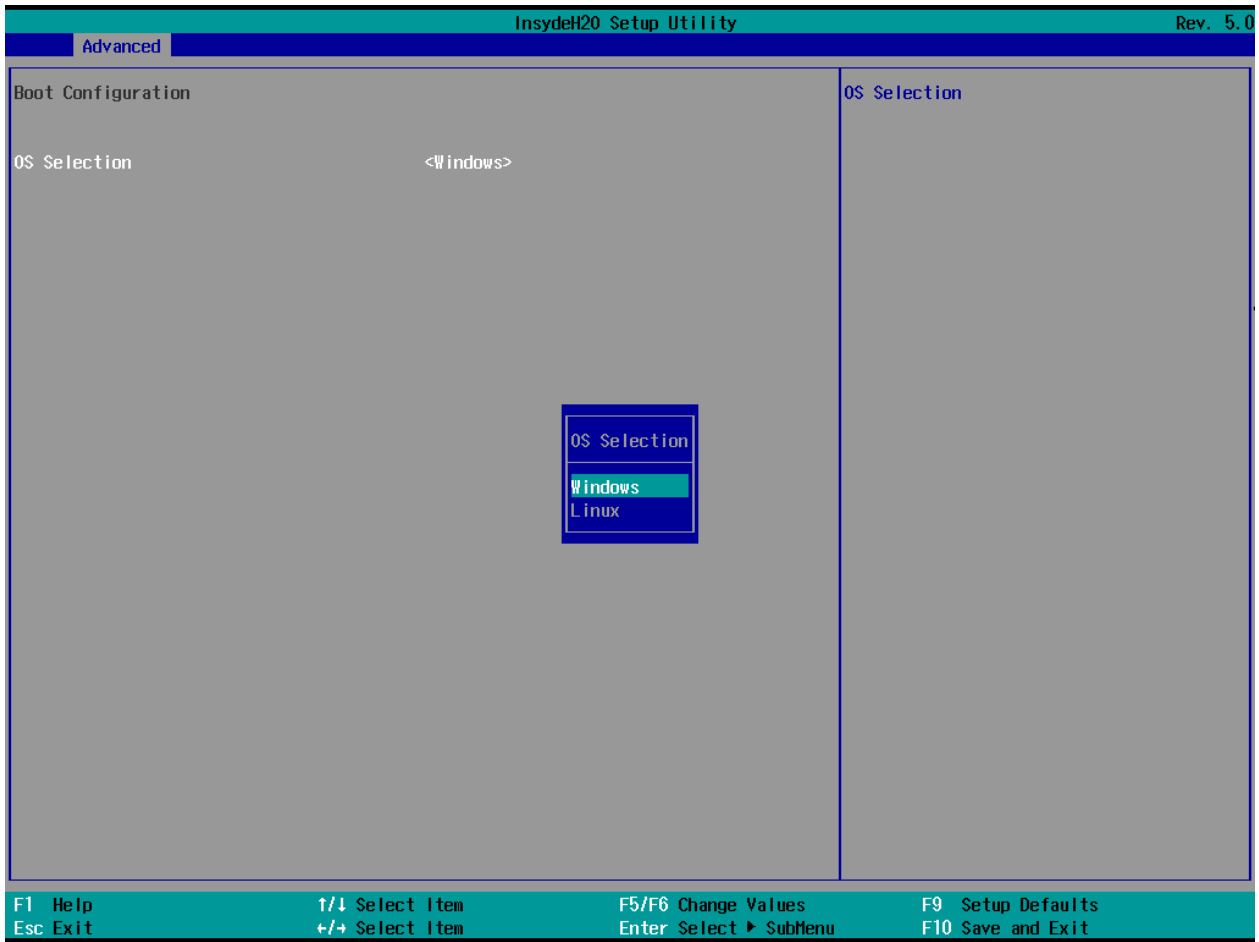

3.2.2.2 Uncore Configuration

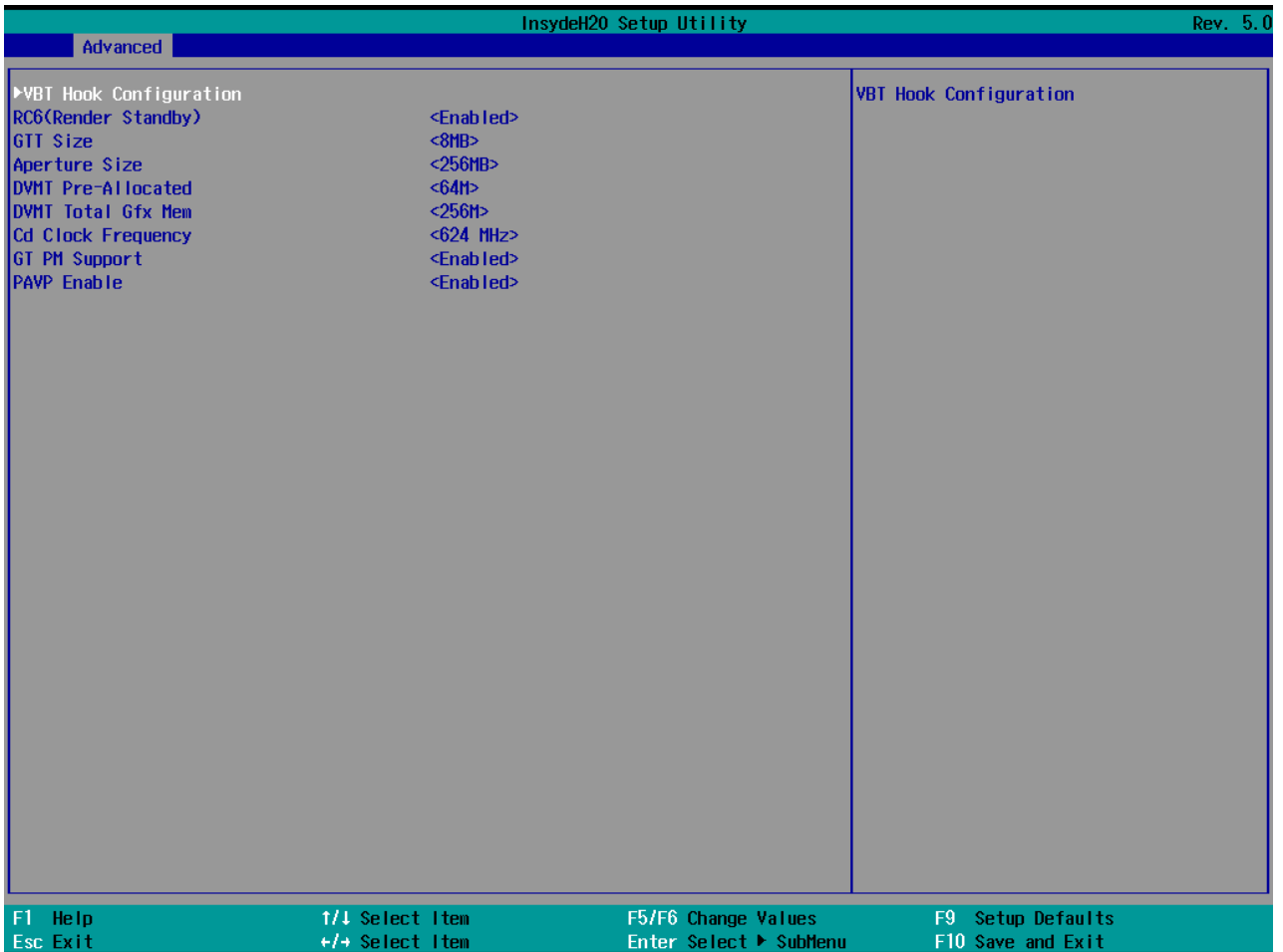

BIOS Setting	Description	Setting Option	Effect
WBT Hook Configuration	WBT Hook Configuration	Enabled/ Disabled	Enable/ Disabled WBT Hook
RC6 (Render Standby)	Check to enable render standby support, R6C should be enabled if S0ix is enabled.	Enabled/ Disabled RC6 (Render Standby)	Enable/ Disabled RC6 (Render Standby)
GTT Size	Select the GTT size.	2 MB/ 4 MB/ 8 MB	Select the GTT size.
Aperture Size	Select the Aperture size.	256 MB	Select the Aperture size.
DVMT Pre-Allocated	Select DVMT Pre-Allocated.	64 M / 96 M/ 128M/ 160M / 192M/ 224M/ 256M/ 288M/ 320M/ 352M/ 384M/ 416M/ 448M/ 480M/ 512M	Select DVMT 5.0 Pre-Allocated (Fixed) Graphics Memory size used by the Internal Graphics Device.
DVMT Total Gfx Mem	Select DVMT Total Gfx Mem.	128M/ 256 M / MAX	Select DVMT 5.0 total memory size used by the Internal Graphics Device.
Cd Clock Frequency	Select Cd Clock Frequency.	144 MHz/ 288 MHz/ 384MHz/ 576MHz/ 624 MHz	Select the highest Cd Clock frequency supported by the platform
GT PM Support	Configure GT PM Support settings.	Enabled/ Disabled	Enable/ Disable GT PM Support
PAVP Enable	Enable/ Disable PAVP	Enabled/ Disabled	Enable/ Disable PAVP

3.2.2.3 South Cluster Configuration

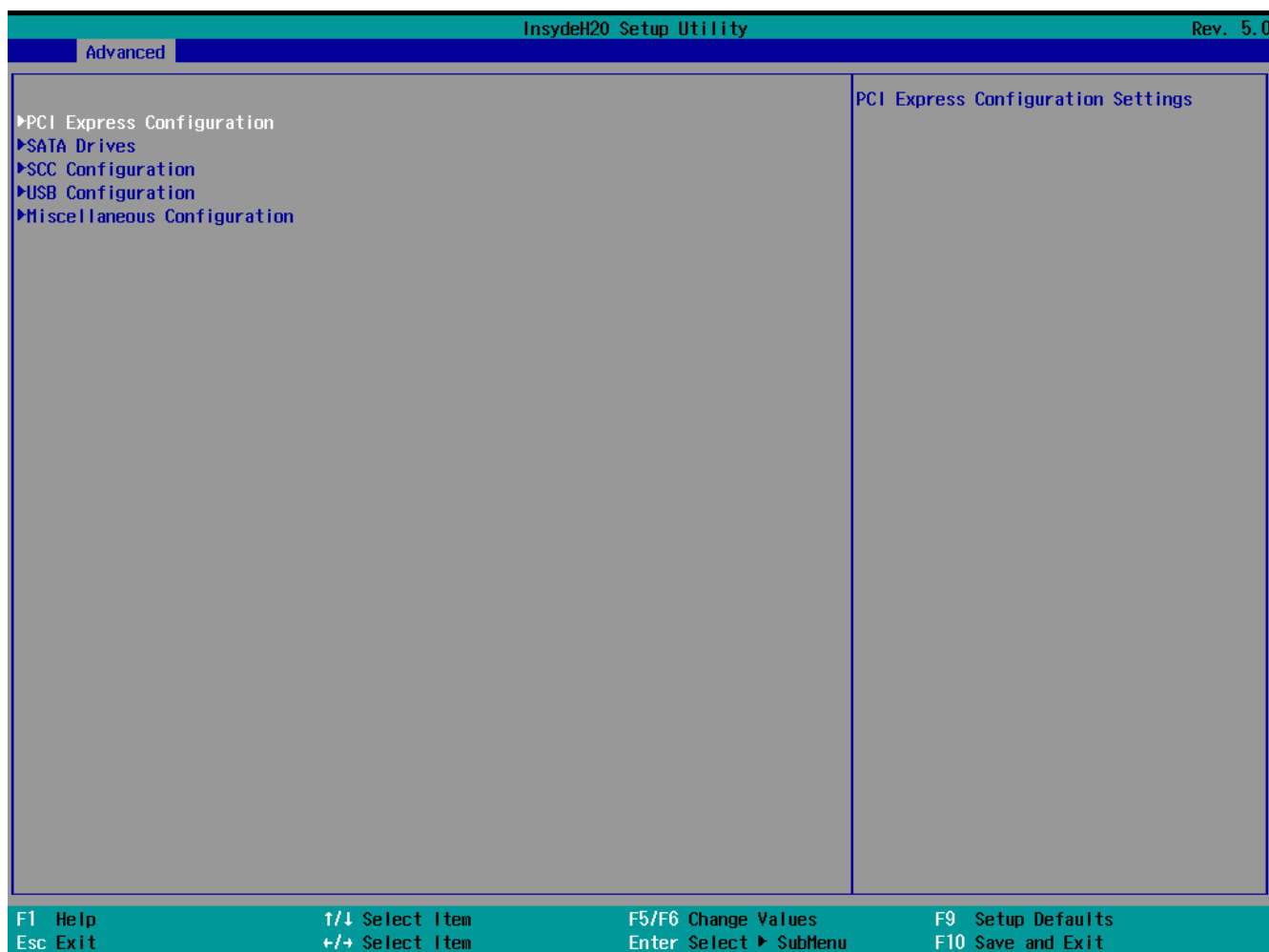

BIOS Setting	Description	Setting Option	Effect
PCI Express Configuration	PCI Express Configuration settings.	Enter	Opens submenu
SATA Drives	SATA Drives settings.	Enter	Opens submenu
USB Configuration	USB Configuration settings.	Enter	Opens submenu
Miscellenaus Configuration	Miscellenaus Configuration settings.	Enter	Opens submenu

3.2.2.3.1 PCI Express Configuration

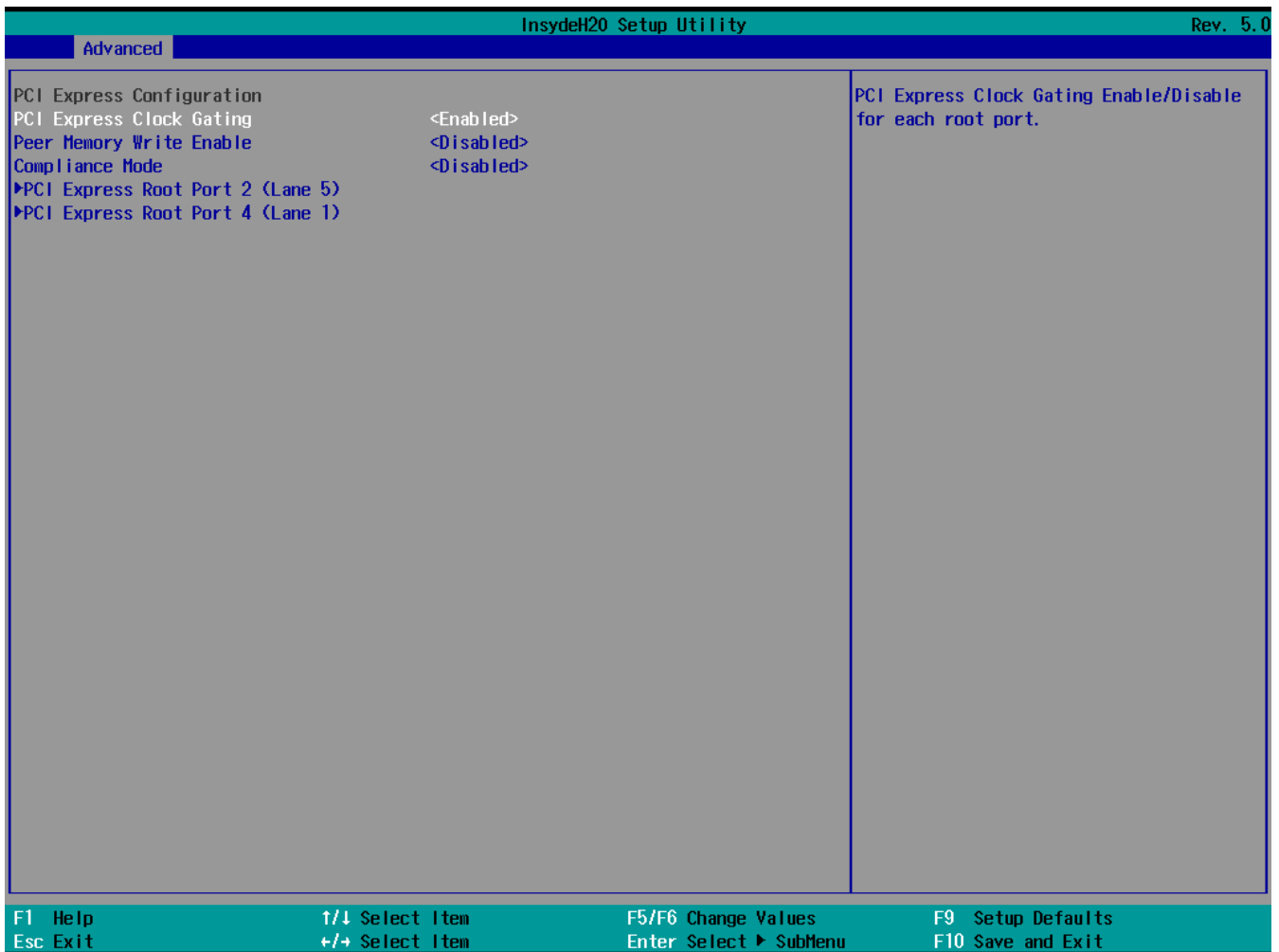

BIOS Setting	Description	Setting Option	Effect
PCI Express Clock Gating	PCI Express Clock Gating Enable/ Disable for each root port	Enabled/ Disabled	Enable/ Disable PCI Express Clock Gating for each root port
Peer Memory Write Enable	Enable Peer Memory Write	Enabled/ Disabled	Enable/ Disable Peer Memory Write
Compliance Mode	Enable Compliance Mode	Enabled/ Disabled	Enable/ Disable Compliance Mode
PCI Express Root Port 2~4(Lane 5~1)	Control the PCI Root Port.	Enter	Opens submenu. Auto: To disable unused root port automatically for the most optimum power saving. Enable: Enable PCIe Root Port. Disable: Disable PCIe Root Port.

InsydeH20 Setup Utility		Rev. 5.0
Advanced		
PCI Express Root Port 2 (Lane 5)	<Auto>	Control the PCI Express Root Port. AUTO: To disable unused root port automatically for the most optimum power savings. Enable: Enable PCIe root port Disable: Disable PCIe root port
If DISABLED, goto ENABLE first then AUTO on next boot		
ASPM	<Disabled>	
L1 Substates	<Disabled>	
ACS	<Enabled>	
URR	<Disabled>	
FER	<Disabled>	
NFER	<Disabled>	
CER	<Disabled>	
CTO	<Disabled>	
SEFE	<Disabled>	
SENF	<Disabled>	
SECE	<Disabled>	
PME SCI	<Enabled>	
Hot Plug	<Disabled>	
PCIe Speed	<Auto>	
Transmitter Half Swing	<Disabled>	
Extra Bus Reserved	[0]	
Reserved Memory	[10]	
Reserved I/O	[4]	
PCH PCIe LTR Configuration		
PCH PCIe LTR	<Enabled>	
Snoop Latency Override	<Auto>	
Non Snoop Latency Override	<Auto>	
PCIe LTR Lock	<Disabled>	
PCIe Selectable De-emphasis	<Enabled>	
F1 Help ↑/↓ Select Item F5/F6 Change Values F9 Setup Defaults Esc Exit +/+ Select Item Enter Select ► SubMenu F10 Save and Exit		

InsydeH20 Setup Utility		Rev. 5.0
Advanced		
PCI Express Root Port 4 (Lane 1)	<Auto>	Control the PCI Express Root Port. AUTO: To disable unused root port automatically for the most optimum power savings. Enable: Enable PCIe root port Disable: Disable PCIe root port
If DISABLED, goto ENABLE first then AUTO on next boot		
ASPM	<Disabled>	
L1 Substates	<Disabled>	
ACS	<Enabled>	
URR	<Disabled>	
FER	<Disabled>	
NFER	<Disabled>	
CER	<Disabled>	
CTO	<Disabled>	
SEFE	<Disabled>	
SENF	<Disabled>	
SECE	<Disabled>	
PME SCI	<Enabled>	
Hot Plug	<Disabled>	
PCIe Speed	<Auto>	
Transmitter Half Swing	<Disabled>	
Extra Bus Reserved	[0]	
Reserved Memory	[10]	
Reserved I/O	[4]	
PCH PCIe LTR Configuration		
PCH PCIe LTR	<Enabled>	
Snoop Latency Override	<Auto>	
Non Snoop Latency Override	<Auto>	
PCIe LTR Lock	<Disabled>	
PCIe Selectable De-emphasis	<Enabled>	
F1 Help ↑/↓ Select Item F5/F6 Change Values F9 Setup Defaults Esc Exit +/+ Select Item Enter Select ► SubMenu F10 Save and Exit		

3.2.2.3.2 Chipset-SATA Controller Configuration

InsydeH20 Setup Utility Rev. 5.0

Advanced

<p>Chipset-SATA Controller Configuration</p> <p>Chipset SATA <Enabled></p> <p>SATA Mode Selection <AHCI></p> <p>SATA Interface Speed <Gen3></p> <p>SATA Port 0 Phison SSMPO64 (64.0GB - 6.0GB/s)</p> <p>Software Preserve SUPPORTED</p> <p>SATA Port 0 <Enabled></p>	<p>Enables or Disables the Chipset SATA Controller.</p>
---	---

F1 Help
↑/↓ Select Item
F5/F6 Change Values
F9 Setup Defaults

Esc Exit
+/- Select Item
Enter Select ► SubMenu
F10 Save and Exit

BIOS Setting	Description	Setting Option	Effect
Chipset SATA	Chipset SATA Controller. Settings.	Enabled/ Disabled	Enable or Disable the Chipset SATA Controller.
SATA Mode Selection	Select SATA Mode. When you activate AHCI mode, it increases the speed of access to files in memory devices and improves overall performance of your computer	AHCI	AHCI for a system using SATA disks (non-RAID)
		RAID	RAID to create an Intel Matrix RAID
		Disabled	Disable both AHCI/ RAID functions
SATA Interface Speed	Select SATA Interface Speed	Gen3	
SATA Port 0	SATA Port 0 settings.	Enabled/ Disabled	Enable or Disable SATA Port 0
SATA Port 1	SATA Port 1 settings.	Enabled/ Disabled	Enable or Disable SATA Port 1

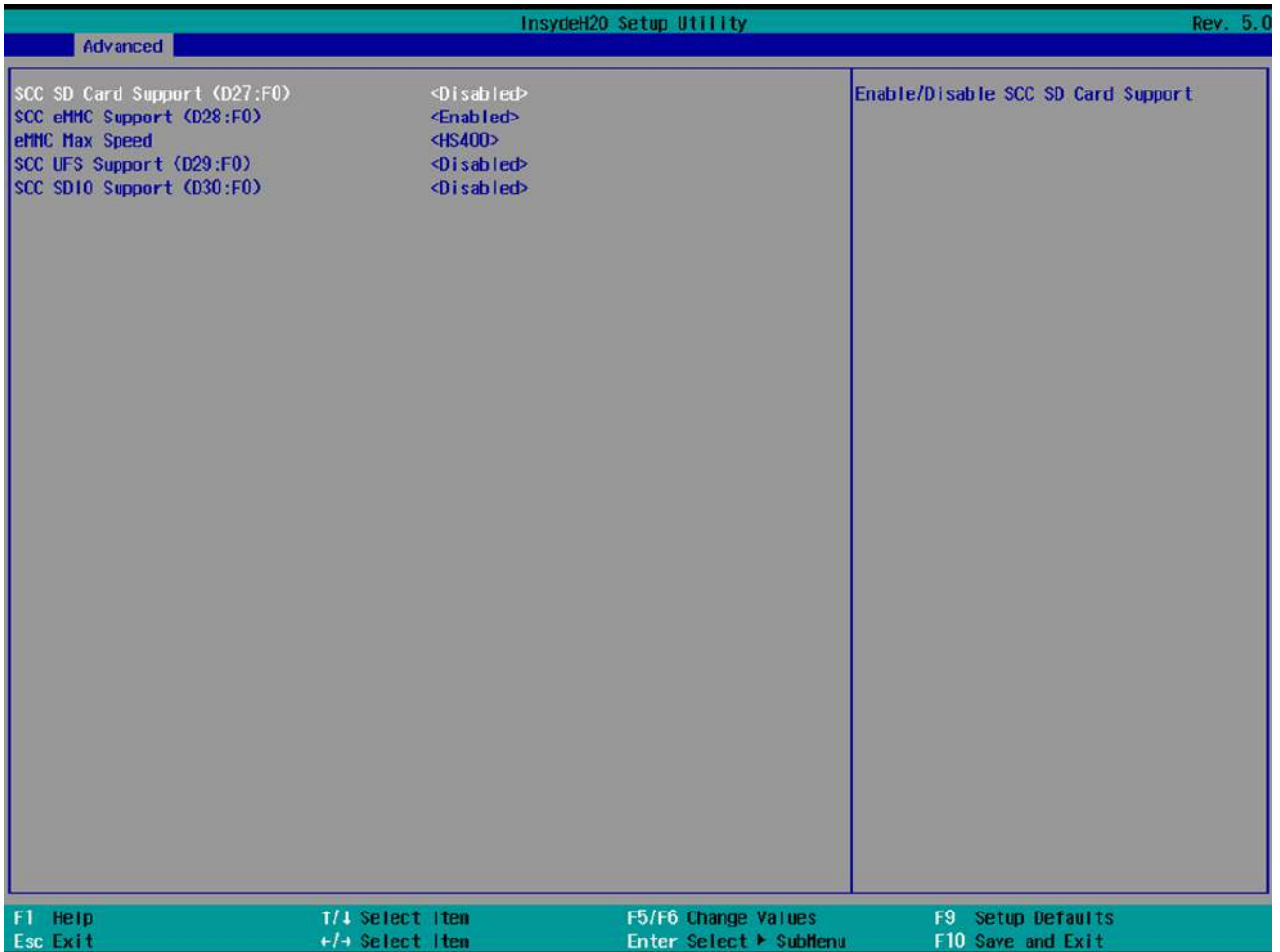

3.2.2.3.3 USB Pre-Port Control

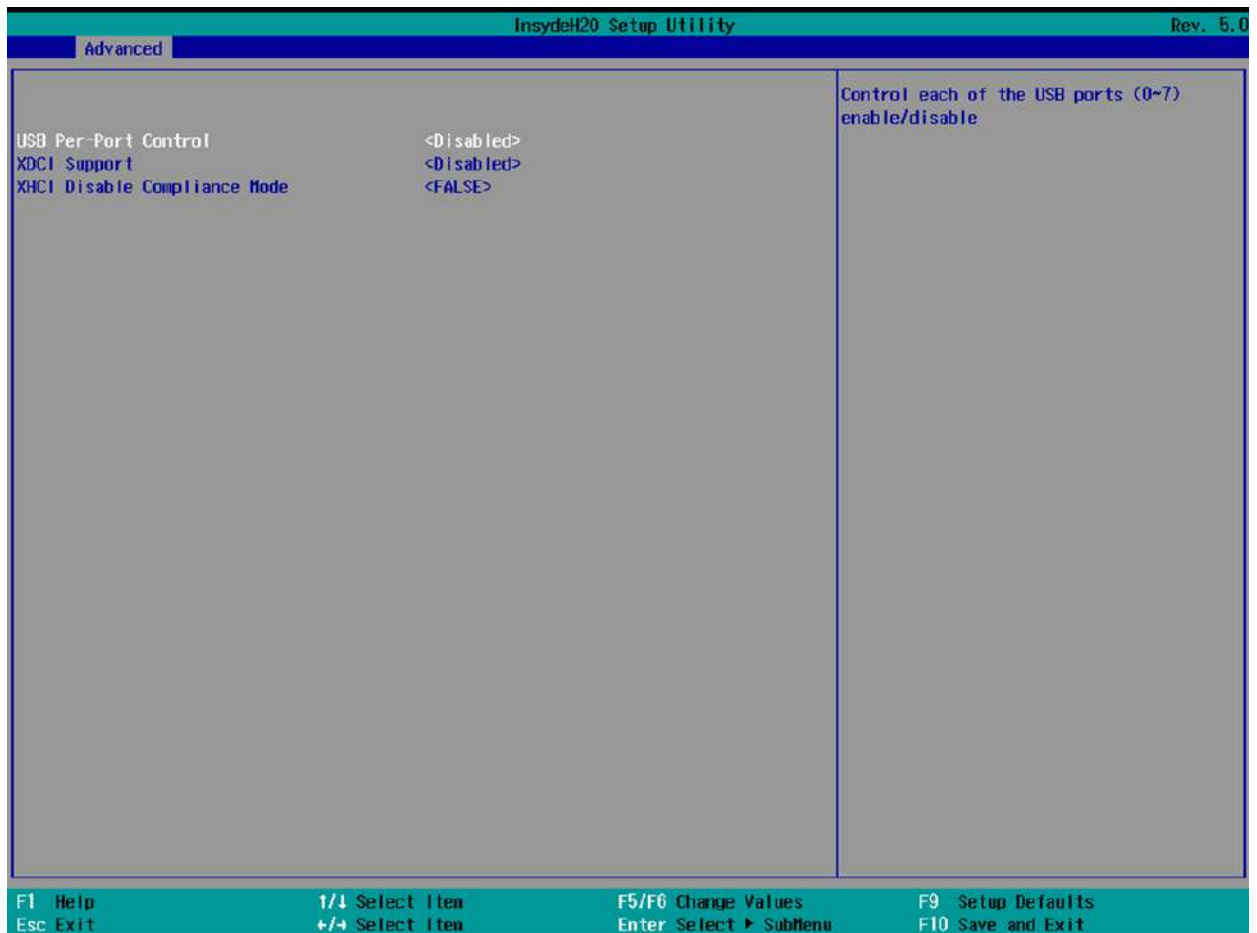

BIOS Setting	Description	Setting Option	Effect
USB Per-Port Control	USB Per-Port Control a settings.	Enabled/ Disabled	Control each of the USB ports (0~7) enable/ disable.
XDCI Support	Allows you to enable or disable xDCI (USB OTG Device).	Enabled/ Disabled	Enable or Disable XDCI Support
XHCI Disable Compliance Mode	Option to disable Compliance Mode.	FALSE	Default is FALSE to not disable Compliance Mode.
		TRUE	Set TRUE to disable Compliance Mode.

3.2.2.3.4 Miscellaneous Control

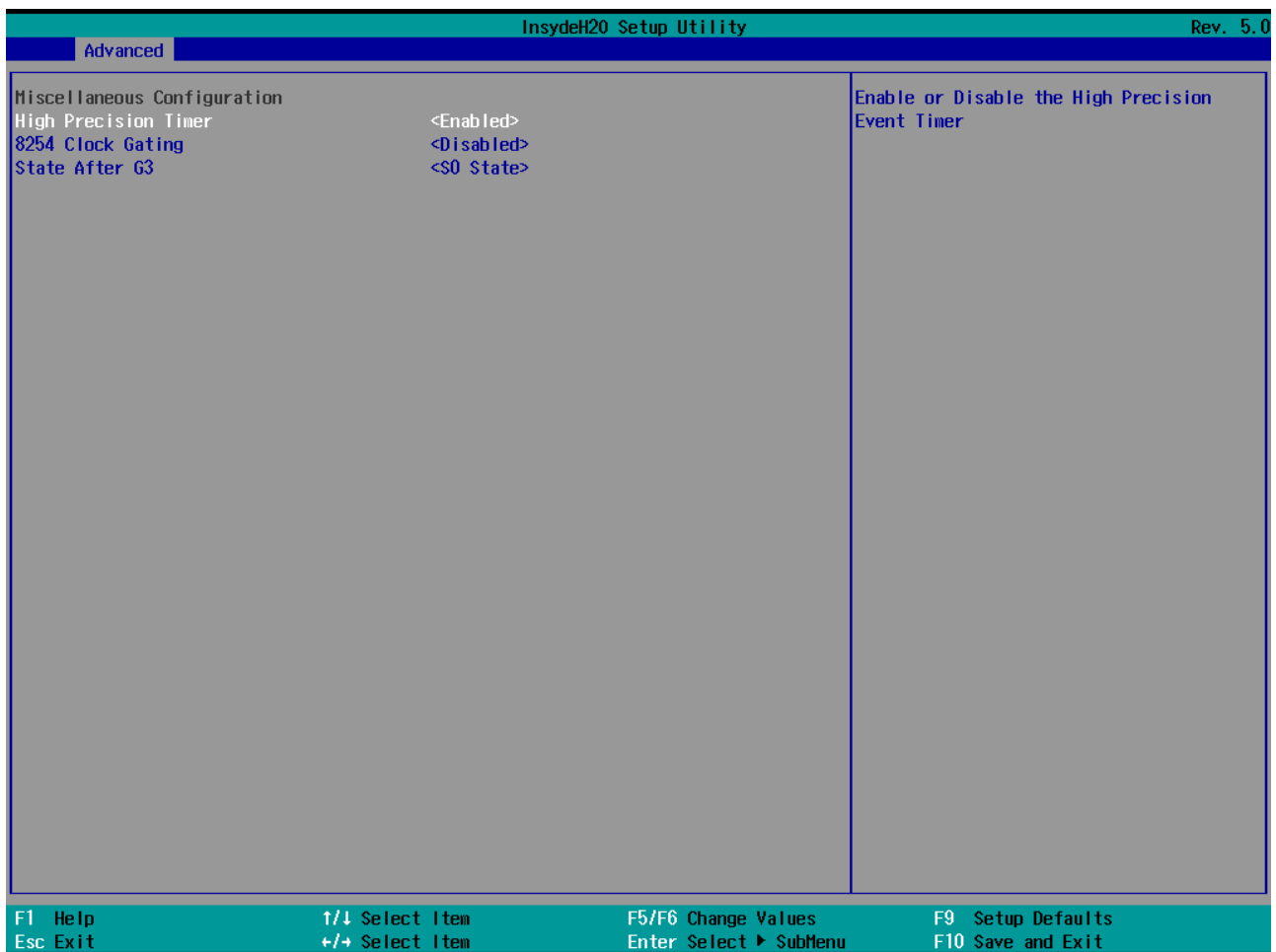

BIOS Setting	Description	Setting Option	Effect
High Precision Timer	High Precision Timer settings	Enabled/ Disabled	Enable or Disable the High Precision Event Timer
8254 Clock Gating	8254 Clock Gating	Enabled/ Disabled	Enable or Disable 8254 Clock Gating
State After G3	Specify what state to go to when power is re-applied after a power failure (G3 state)	S0	System will boot directly as soon as power applied.
		S5	System keeps in power-off state until power button is pressed.

3.2.2.3.5 TXE Configuration

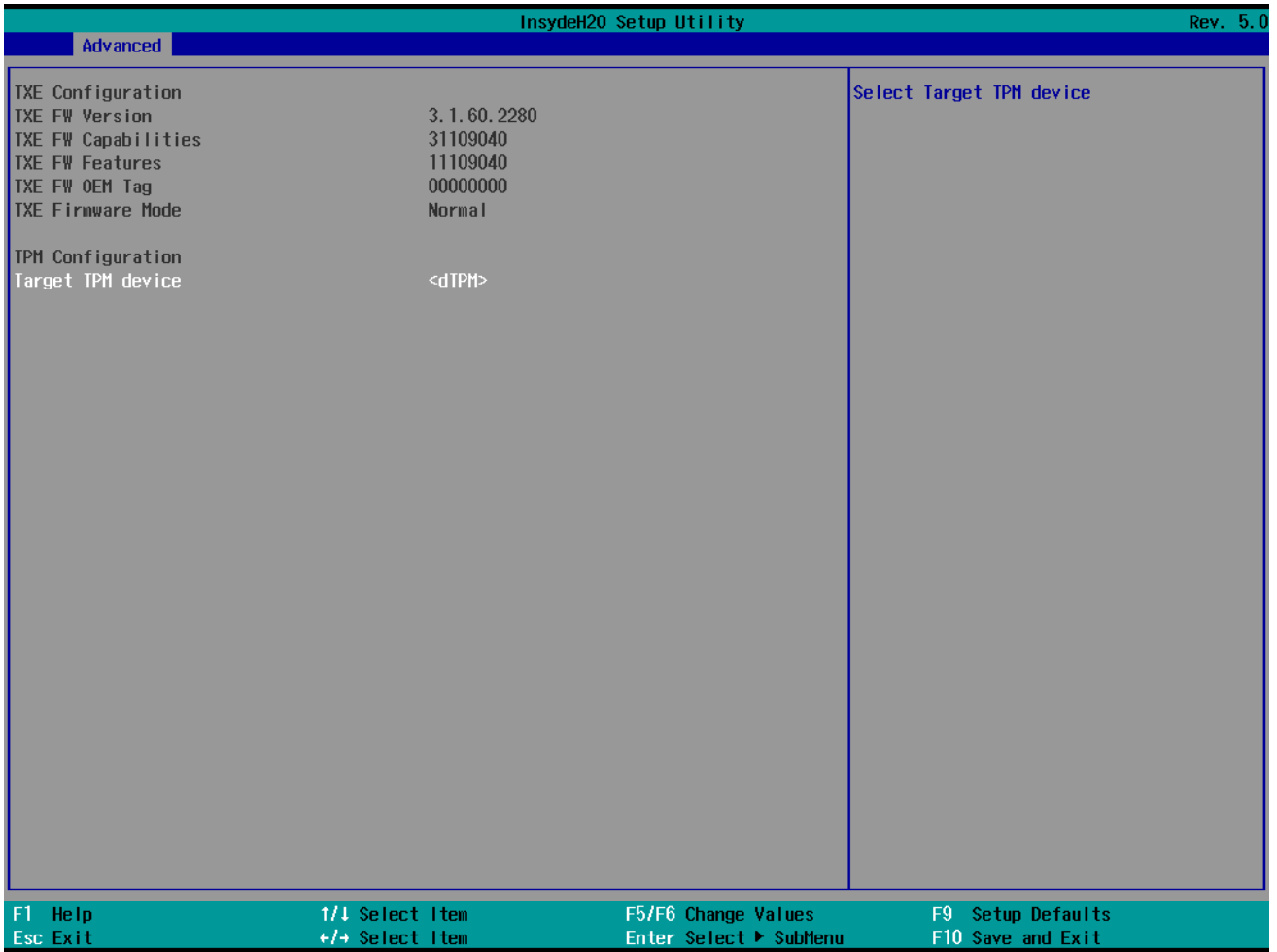

BIOS Setting	Description	Setting Option	Effect
Target TPM Device	Select Target TPM Device	dTPM	Select Target TPM Device

3.2.2.3.6 Thermal Configuration Parameters

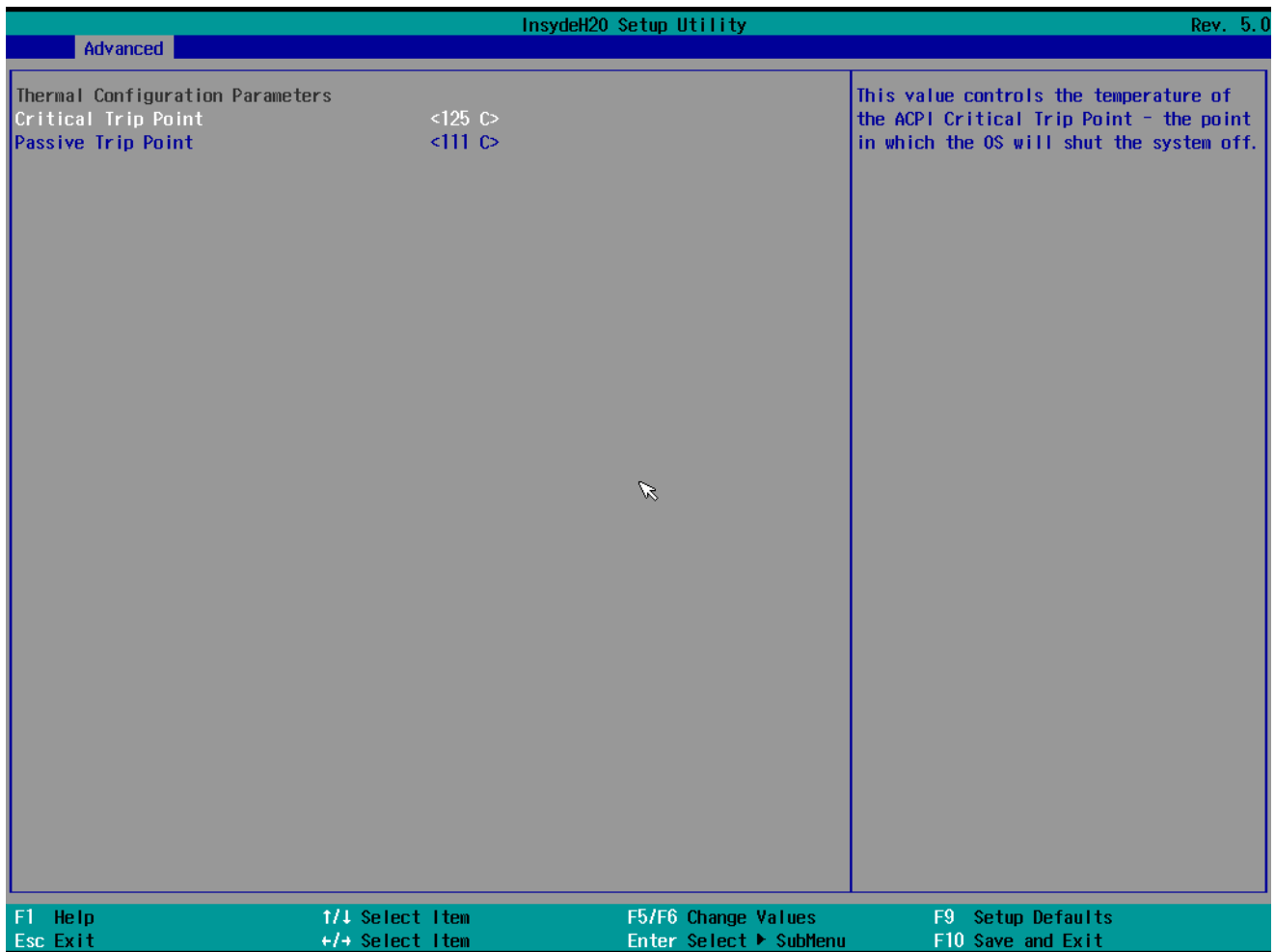

BIOS Setting	Description	Setting Option	Effect
Critical Trip Point	This value controls the temperature of the ACPI Critical Trip Point – the point in which the OS will shut down the system.	125 C	Select the point in which the OS will shut down the system.
Passive Trip Point	This value controls the temperature of the ACPI Passive Trip Point – the point in which CPU is slowed down in order to cool.	111 C	Select the point in which CPU is slowed down in order to cool..

3.2.2.3.7 Serial Port

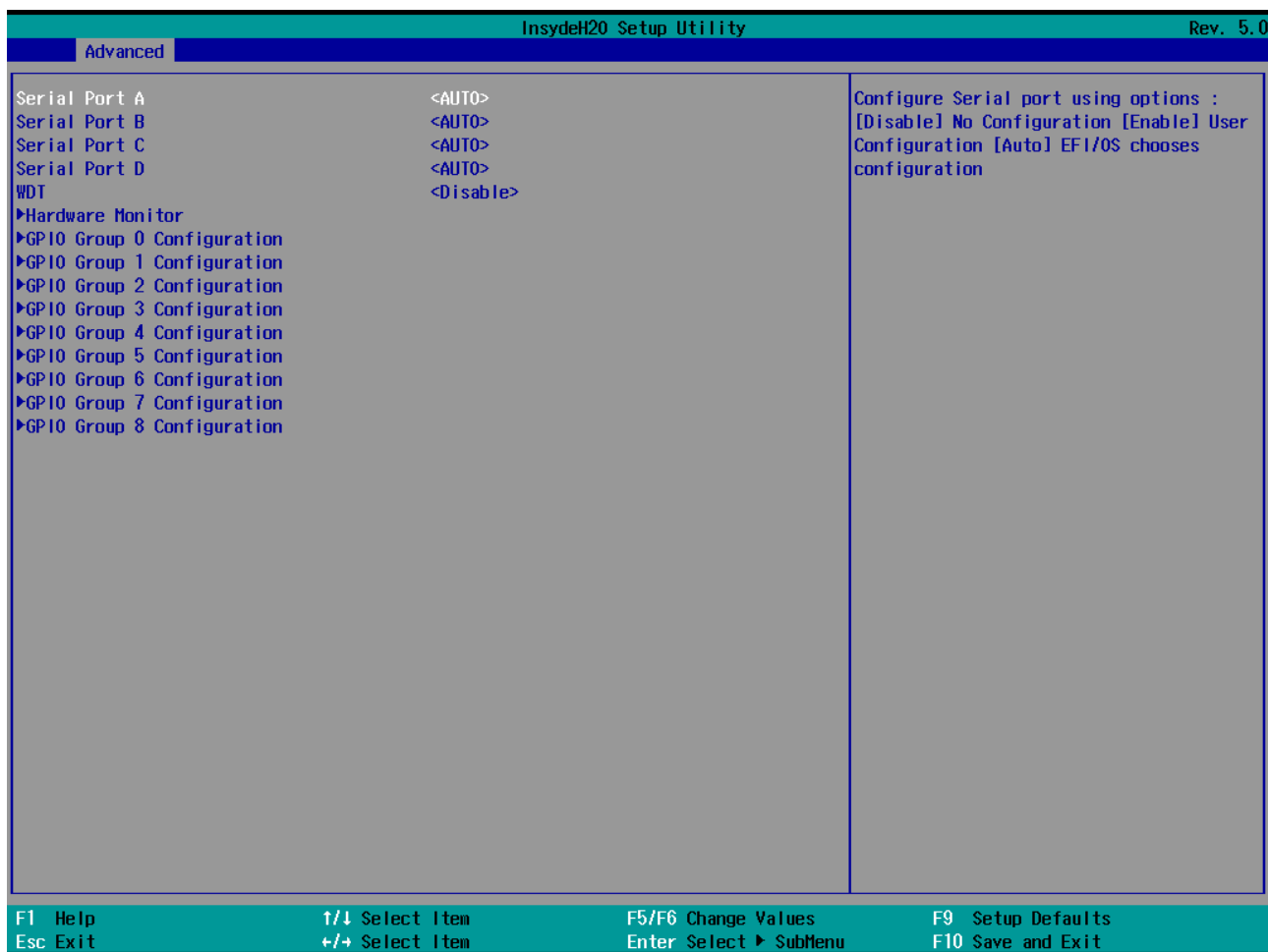

BIOS Setting	Description	Setting Option	Effect
Serial Port A~ D	Configure serial port settings.	Enabled	User configuration
		Disabled	No configuration
		Auto	EFI/ OS chooses configuration
WDT	WDT count mode and counter settings.	Enabled/ Disabled	Enable or disable WDT. Select WDT settings.
Hardware Monitor	Hardware Monitor settings.	Enter	Open sub-menu
GPIO Group 0~8 Configuration	GPIO Group 0~8 Configuration	Enter	Open sub-menu

3.2.2.3.8 WTD

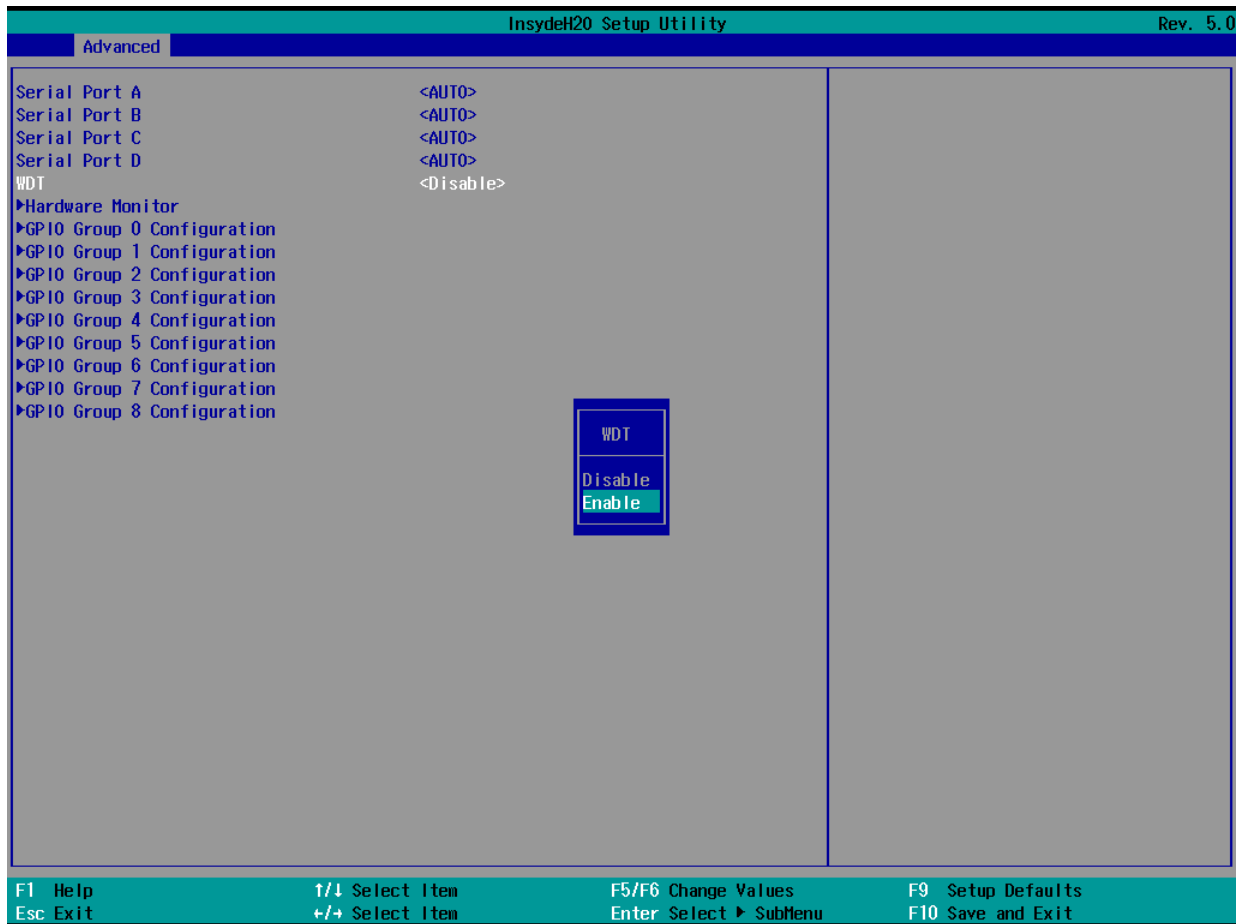

BIOS Setting	Description	Setting Option	Effect
WDT	WDT count mode and counter settings.	Enabled/ Disabled	Enable or disable WDT. Select WDT settings.

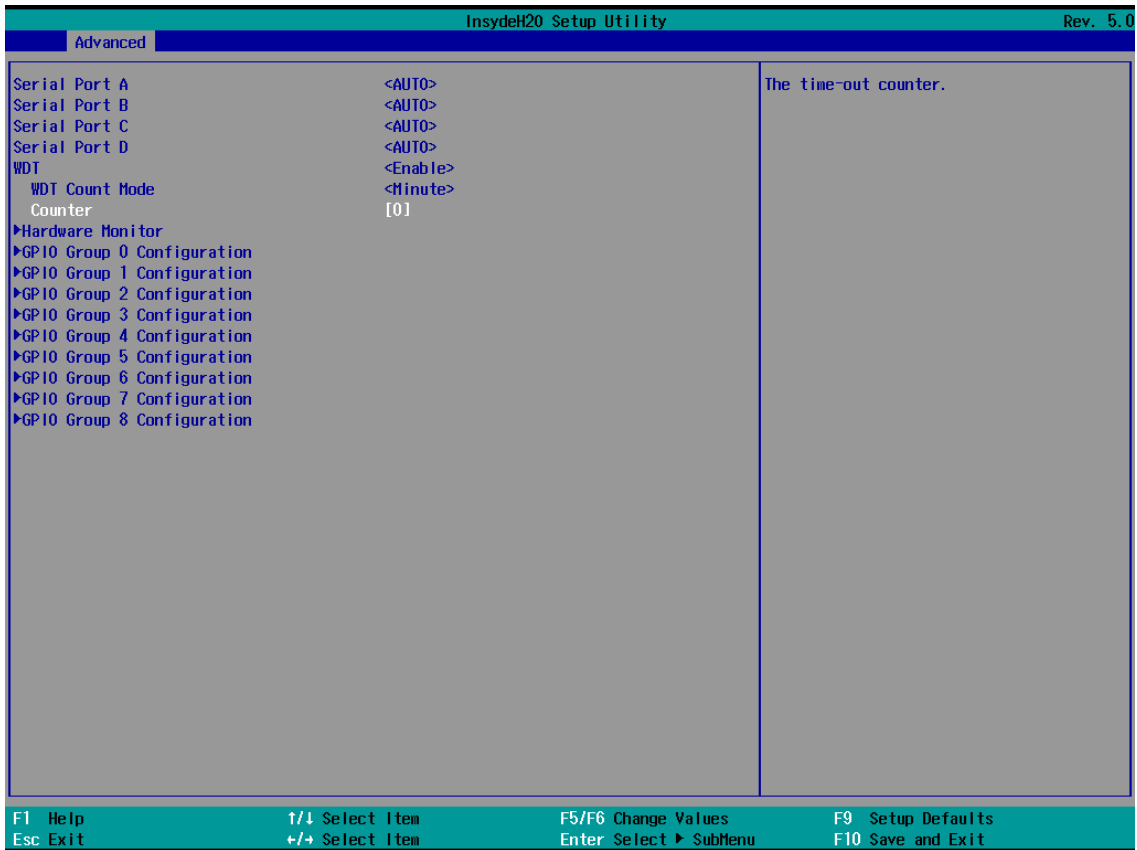

BIOS Setting	Description	Setting Option	Effect
WDT Count Mode	WDT Count Mode	Default [Minute]	Set the timeout counter to [Minute].
Counter	The timeout counter.	Default [0] Please change to [5]	Set the timeout counter to [5].

3.2.2.3.9 Hardware Monitor

InsydeH20 Setup Utility		Rev. 5.0
Advanced		
Hardware Monitor		
Voltage		
VCC (V)	3.456 V	
VIN1 (V)	0.864 V	
VIN2 (V)	12.232 V	
VIN3 (V)	3.456 V	
VIN4 (V)	5.549 V	
VASB3 (V)	3.456 V	
VBAT	3.312 V	
VASB5 (V)	5.280 V	
Temperature		
Temperature 0 (°C/°F)	36.0 C/ 96.8 F	
Temperature 2 (°C/°F)	13.0 C/ 55.4 F	
Fan Speed		
F1 Help ↑/↓ Select Item F5/F6 Change Values F9 Setup Defaults Esc Exit +/→ Select Item Enter Select ► SubMenu F10 Save and Exit		

3.2.2.3.10 General Purpose Group 0 Input/ Output

InsydeH20 Setup Utility		Rev. 5.0
Advanced		
General Purpose Group 0 Input/Output		User can pull internal resistance push-pull/open-drain
GP1000		
Internal Resistance	<Push Pull>	
Input/Output Mode	<Input>	
GP1001		
Internal Resistance	<Push Pull>	
Input/Output Mode	<Input>	
GP1002		
Internal Resistance	<Push Pull>	
Input/Output Mode	<Input>	
GP1003		
Internal Resistance	<Push Pull>	
Input/Output Mode	<Input>	
GP1004		
Internal Resistance	<Push Pull>	
Input/Output Mode	<Input>	
F1 Help ↑/↓ Select Item F5/F6 Change Values F9 Setup Defaults Esc Exit +/→ Select Item Enter Select ► SubMenu F10 Save and Exit		

BIOS Setting	Description	Setting Option	Effect
Internal Resistance	Internal Resistance settings	Push Pull	User can pull internal resistance push-pull
		Open Drain	User can pull internal resistance open drain
Input/ Output Mode	Select Input/ Output Mode	Input	Set the GPIO pin input
		Output	Set the GPIO pin output

3.2.2.3.11 H2oUve Setup

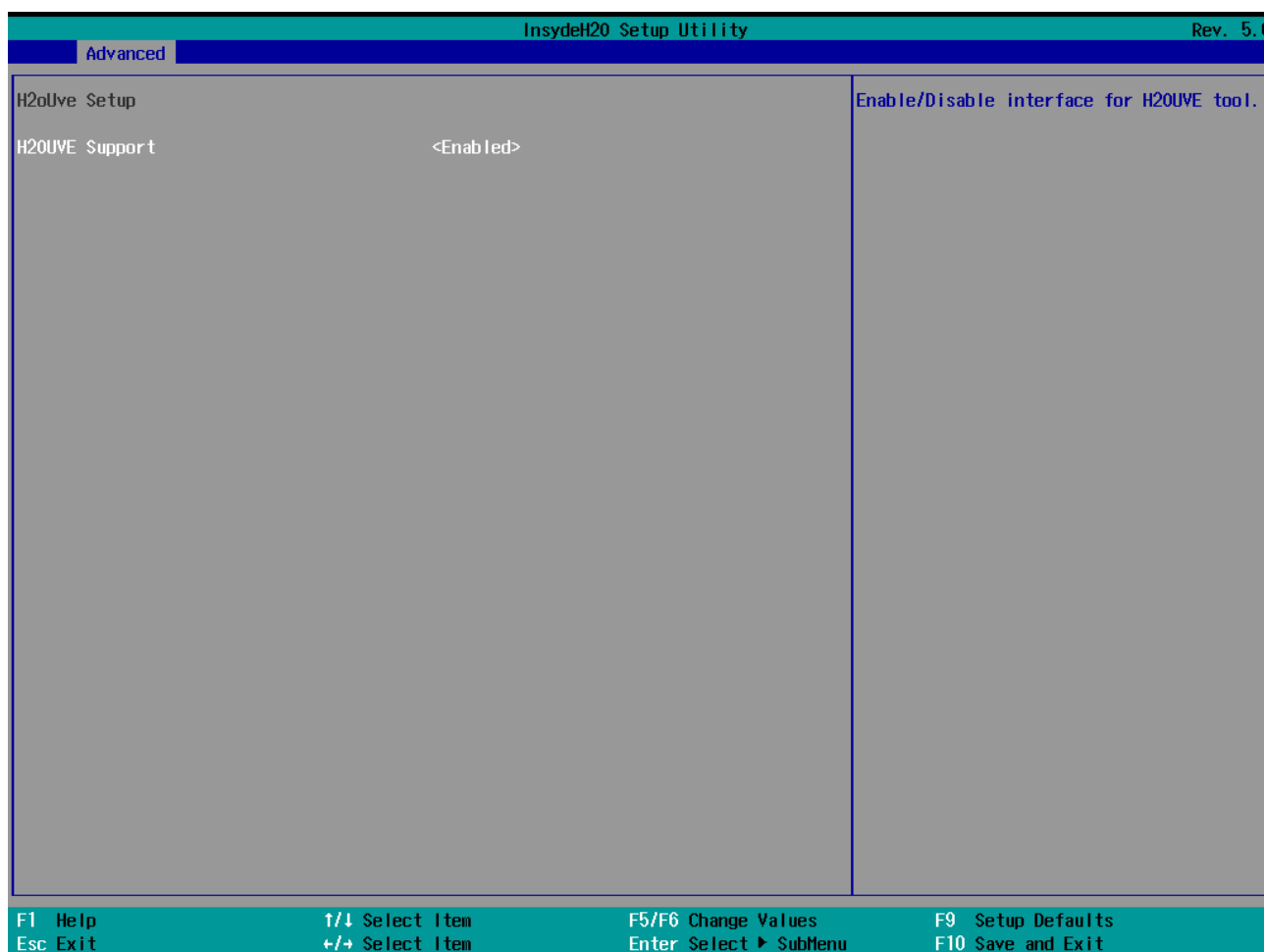

BIOS Setting	Description	Setting Option	Effect
H2oUve Support	H2oUve Support settings	Enabled/ Disabled	Enable or Disable interface for H2oUve tool

3.2.3. Security

InsydeH20 Setup Utility Rev. 5.0

Main Advanced **Security** Power Boot Exit

<pre> Current TPM Device <TPM 2.0 (DTPM)> TPM State All Hierarchies Enabled, Owned TPM Active PCR Hash Algorithm SHA1, SHA256 TPM Hardware Supported Hash Algorithm SHA1, SHA256 TrEE Protocol Version <1.0> TPM Availability <Available> TPM Operation <No Operation> Clear TPM [] Supervisor Password Not Installed User Password Not Installed Set Supervisor Password Set User Password </pre>	<pre> TrEE Protocol Version: 1.0 or 1.1 </pre>
--	--

F1 Help
↑/↓ Select Item
F5/F6 Change Values
F9 Setup Defaults
Esc Exit
+/- Select Item
Enter Select ▶ SubMenu
F10 Save and Exit

BIOS Setting	Description	Setting Option	Effect
TrEE Protocol Version	TrEE Protocol Version: 1.0 or 1.1	1.0 or 1.1	
TPM Availability	TPM Availability	Available	
TPM Operation	TPM Operation	No operation	
Clear TPM	Clear TPM		
Set Supervisor Password	Set Supervisor Password	Custom-setting	Set Supervisor Password

3.2.4 Power

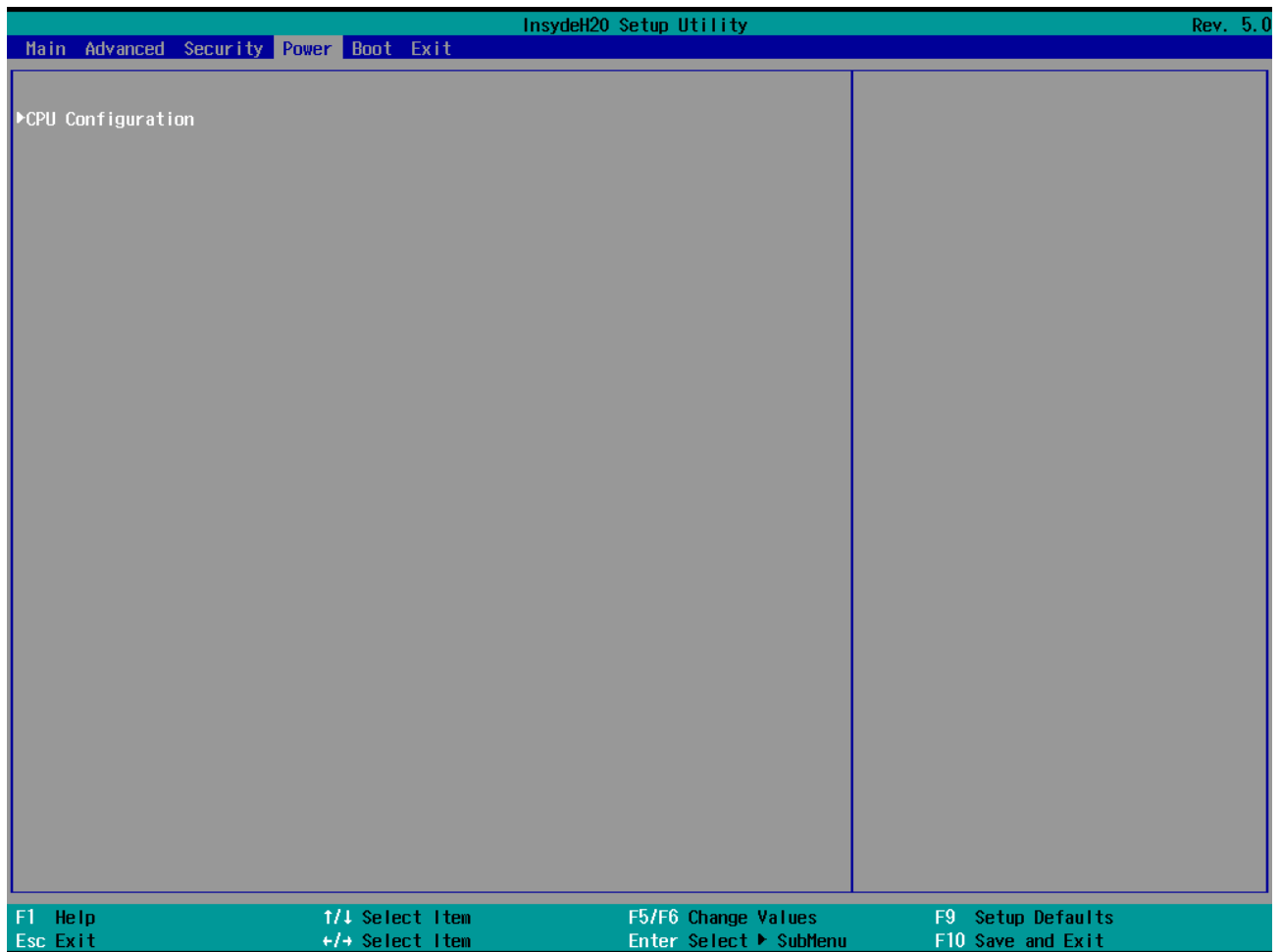

BIOS Setting	Description	Setting Option	Effect
CPU Configuration	CPU Configuration settings	Enter	Opens sub-menu

3.2.4.1 CPU Configuration

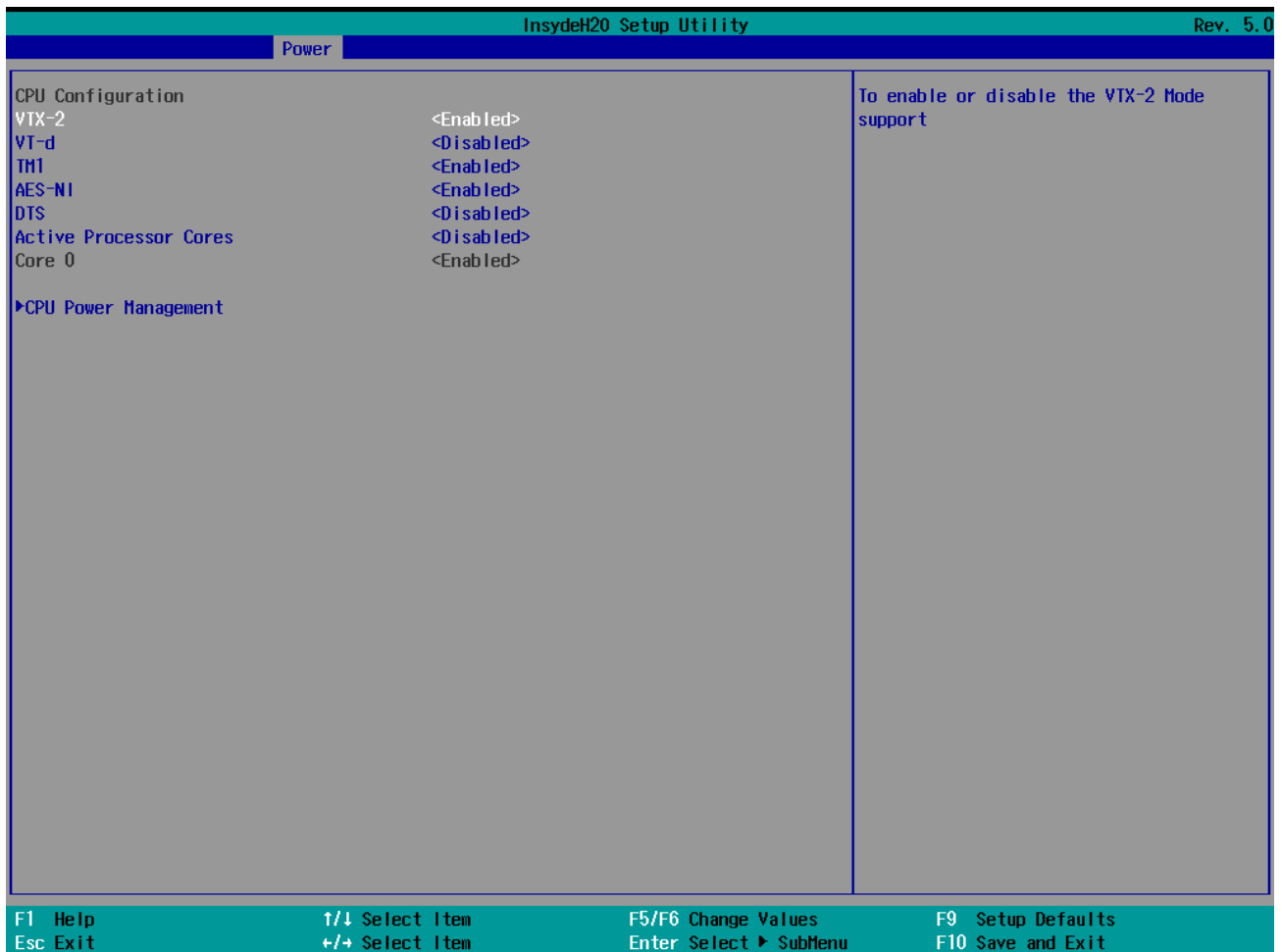

BIOS Setting	Description	Setting Option	Effect
VTX2	VTX2 mode support settings	Enabled/ Disabled	To enable or disable VTX2 mode support
VT-d	VT-d support settings	Enabled/ Disabled	To enable or disable VT-d support
TM1	TM1 support settings	Enabled/ Disabled	To enable or disable TM1 support
AES-N1	AES-N1 support settings	Enabled/ Disabled	To enable or disable AES-N1 support
DTS	DTS support settings	Enabled/ Disabled	To enable or disable DTS support
Active Processor Core	Active Processor Core support settings	Enabled/ Disabled	To enable or disable Active Processor Core
CPU Power Management	CPU Power Management settings	Enter	Opens sub-menu

3.2.4.2 System Power Options

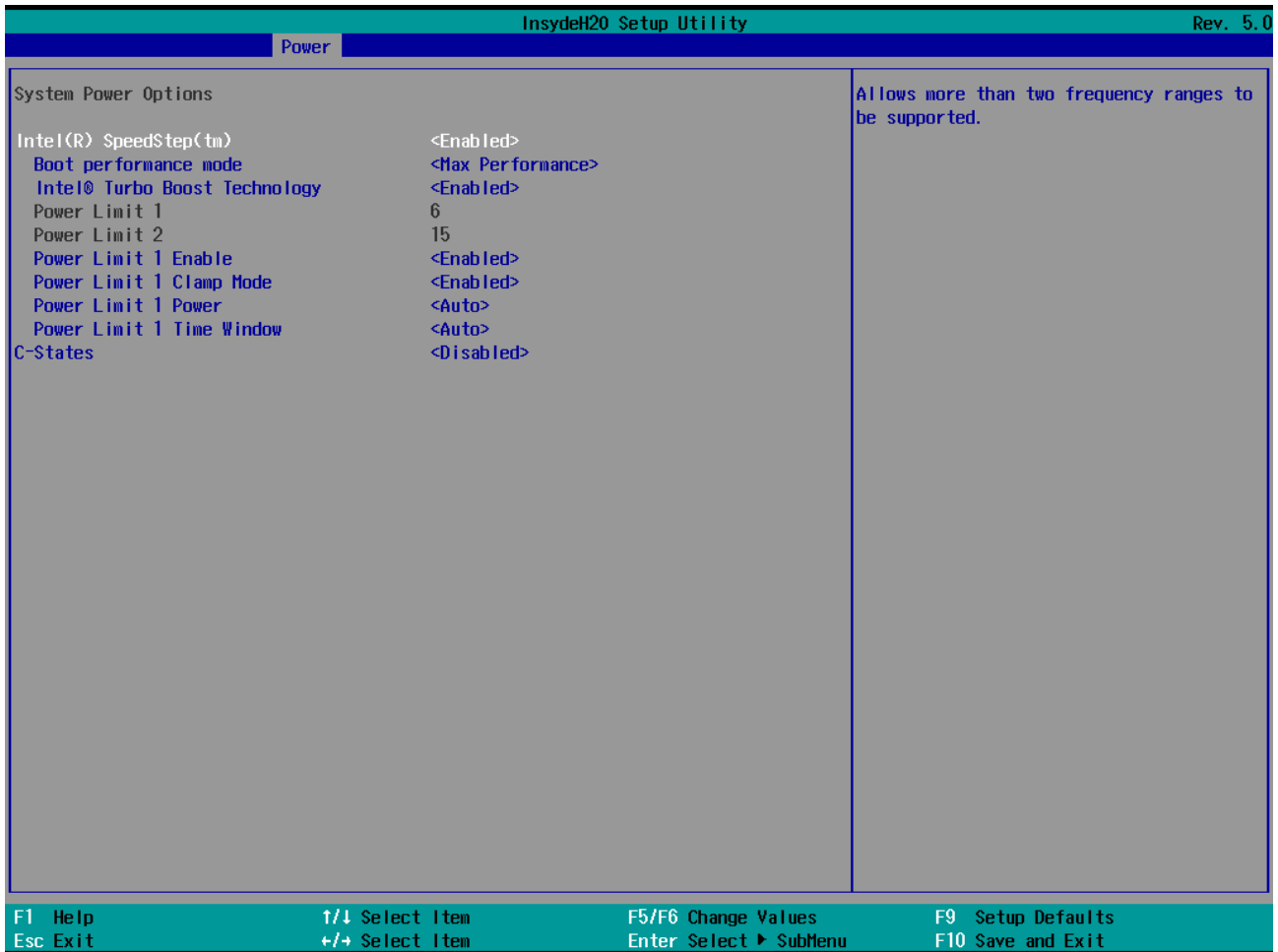

BIOS Setting	Description	Setting Option	Effect
Intel SpeedStep	Intel SpeedStep settings	Enabled/ Disabled	Allows more than two frequency ranges to be supported
Intel Turbo Boost Technology	Intel Turbo Boost Technology settings	Max Performance	Enabled-Enables the logical processor cores on processors supporting hyper threading technology.
Power Limit 1 Enable	Allows changing the power limit settings	Enabled	
Power Limit 1 Clamp Mode	Allows changing the Power Limit 1 Clamp Mode settings	Enabled	
Power Limit 1 Power	Allows changing the power limit Power settings	Auto	
Power Limit 1 Time Window	Allows changing the power limit Time Window settings	Auto	
C-States	C-States power saving states settings	Disabled	C-states are idle power saving states.

3.2.5 Boot

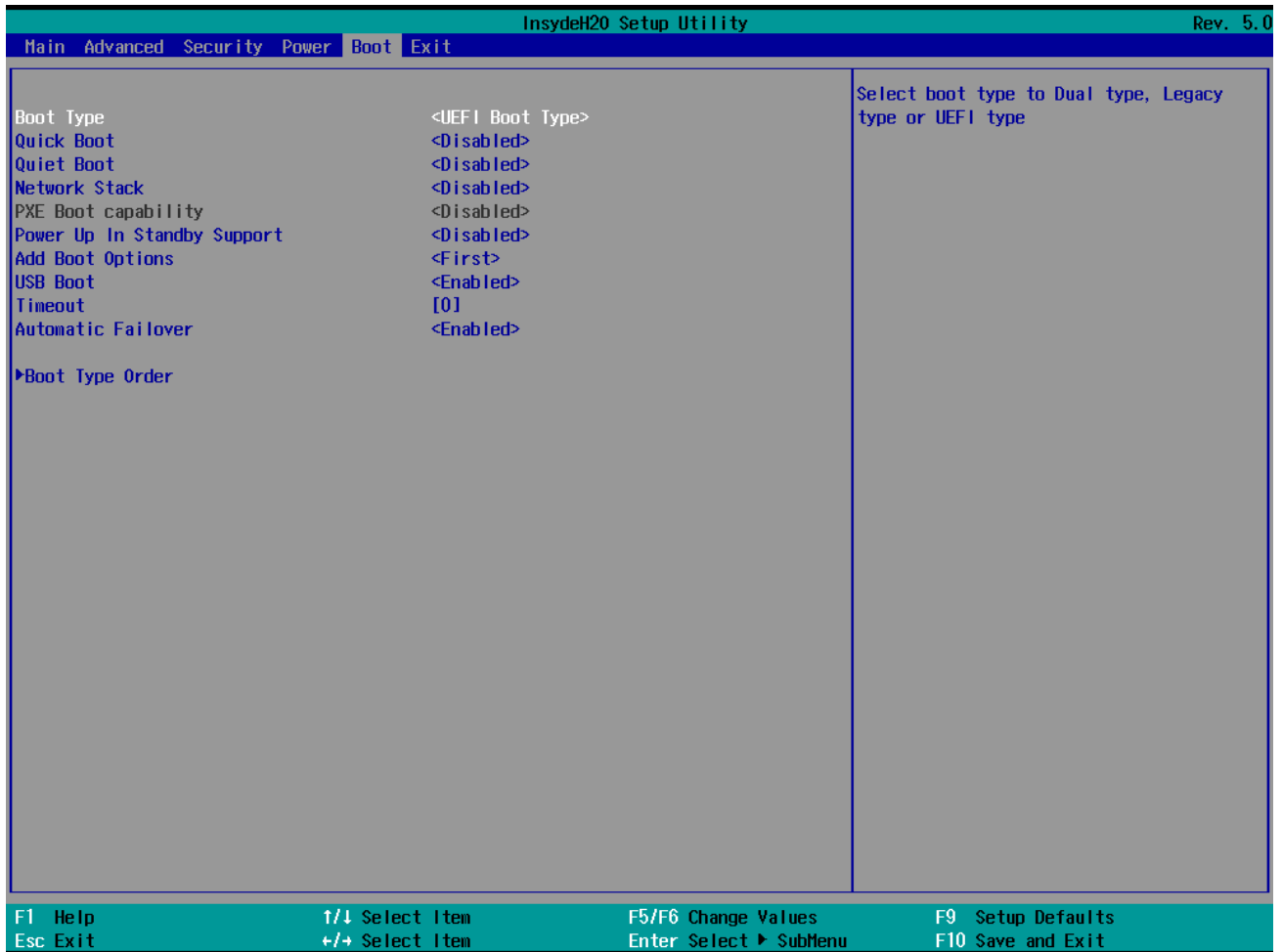

BIOS Setting	Description	Setting Option	Effect
Boot Type	Select Boot Type	Dual/ Legacy/ UEFI	Select boot type to Dual type, Legacy type or UEFI type.
Quick Boot	Quick Boot settings	Enabled/ Disabled	Enable or disable Quick Boot
Quiet Boot	Quiet Boot settings	Enabled/ Disabled	Enable or disable Quiet Boot
Network Stack	Network Stack settings	Enabled/ Disabled	Enable or disable Network Stack
Add Boot Options	Add Boot Options	First	
USB Boot	USB Boot settings	Enabled/ Disabled	Enable or disable USB Boot
Timeout	Timeout settings	0	
Automatic Failover	Automatic Failover settings	Enabled/ Disabled	Enable or disable Automatic Failover
Boot Type Order	Select Boot Type Order	Enter	Opens sub-menu

3.2.5.1 Boot Type Order

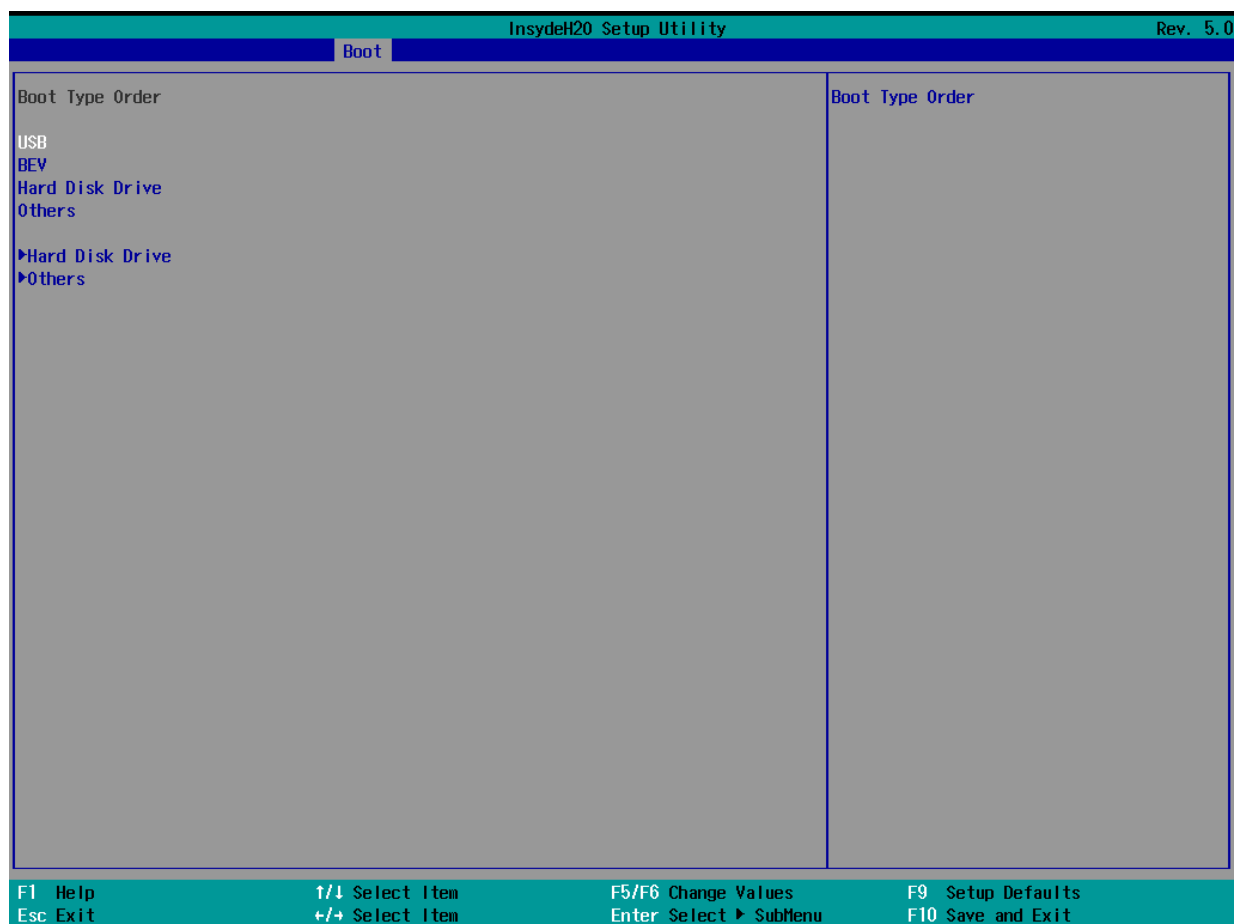

3.2.5.2 Hard Disk Drive

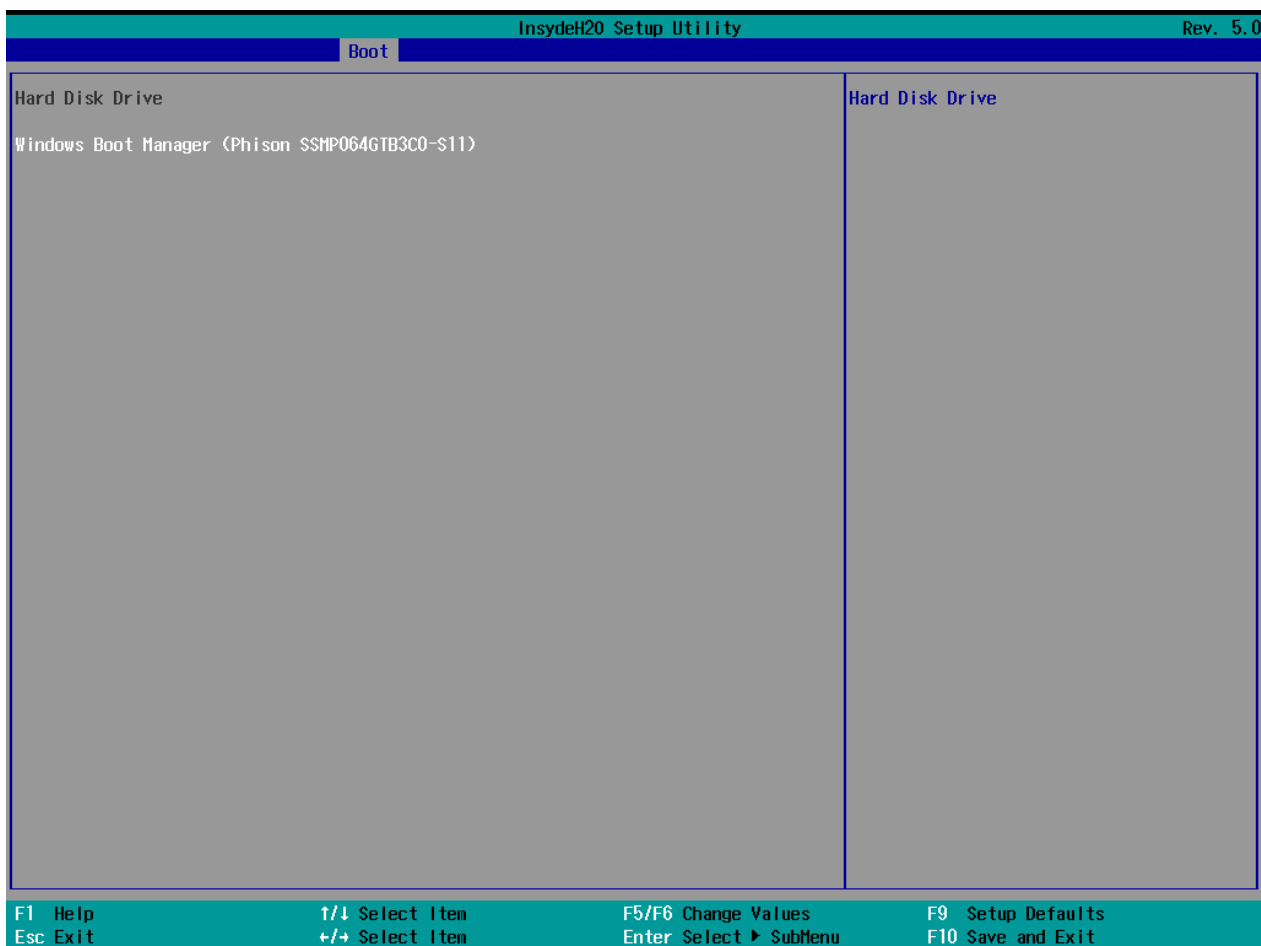

3.2.5.3 Others

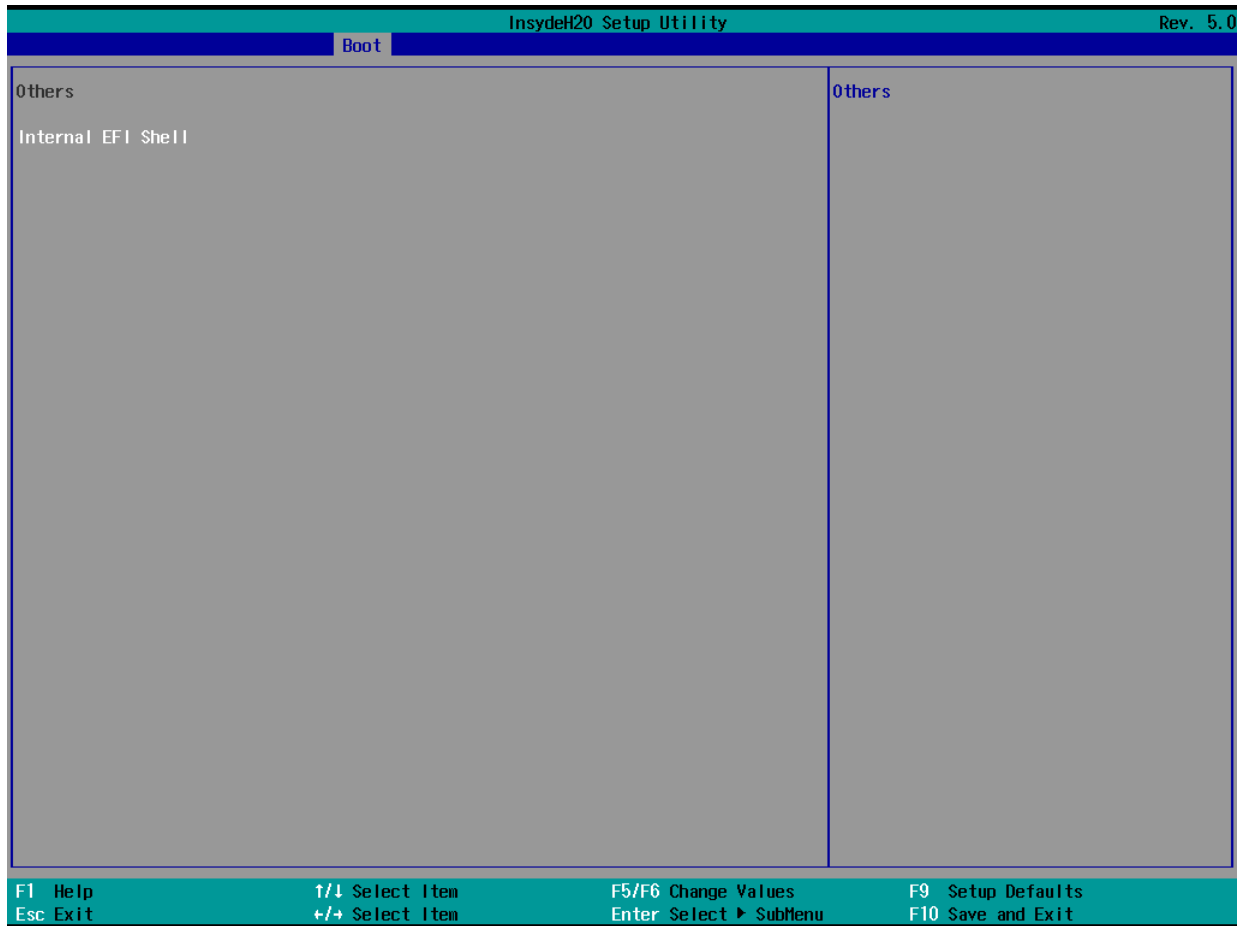

3.2.6 Exit

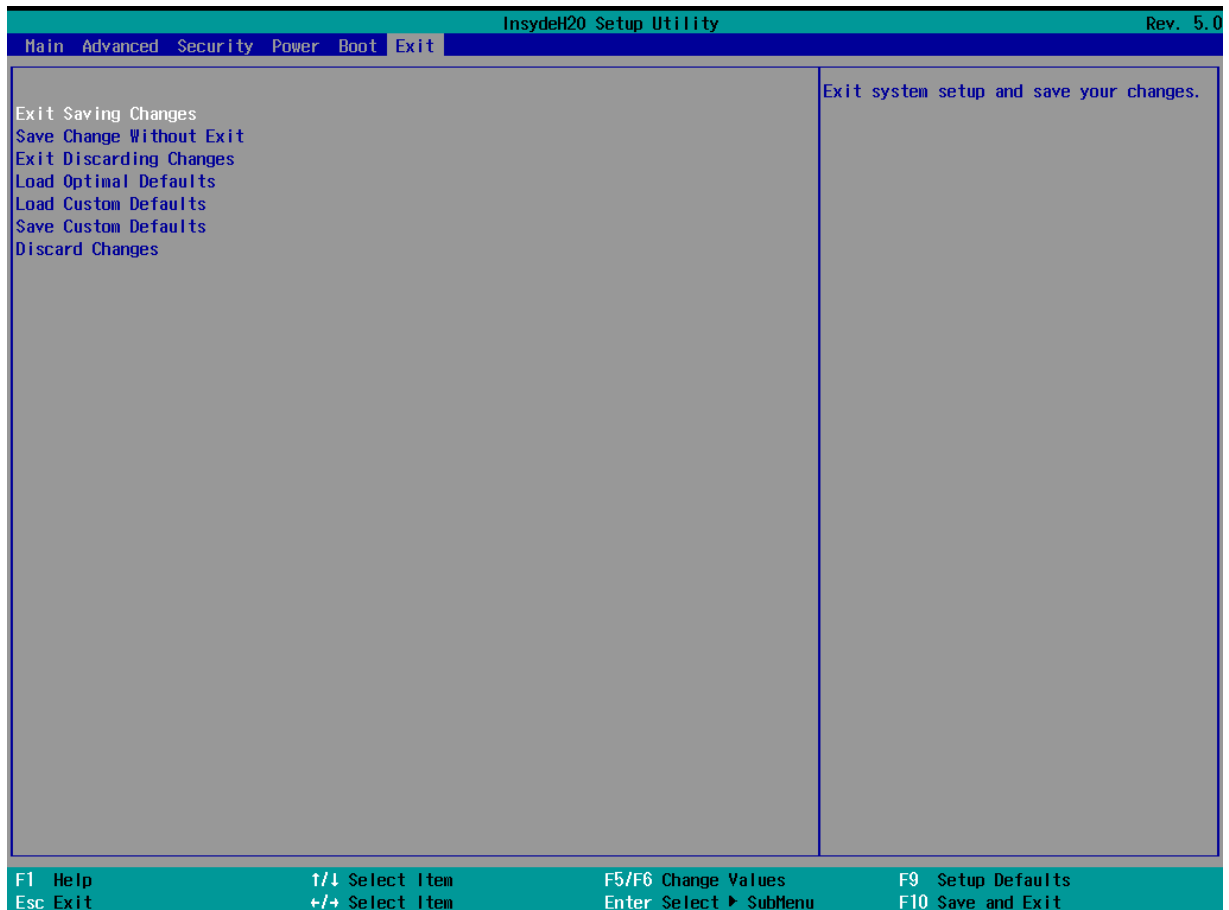

BIOS Setting	Description	Setting Option	Effect
Exit Saving Setting	Exit Saving Setting	Enter	Exit system and save your changes
Exit Saving Setting	Exit Saving Setting	Enter	Save change without exit
Exit Saving Setting	Exit Saving Setting	Enter	Edit discarding changes
Load Optimal Defaults	Load Optimal Defaults	Enter	Load optimal defaults
Save Custom Defaults	Save Custom Defaults	Enter	Save custom defaults
Discard Changes	Discard Changes	Enter	Discard you changes

3.3 Using Recovery Wizard to Restore Computer



Note: Before starting the recovery process, make sure to backup all user data. The data will be lost after the recovery process.



Important: Before starting the recovery process, remove any expansion card.

To enable quick one-key recovery procedure:

1. Connect the computer to the power source. Make sure the computer stays plugged in to power source during the recovery process.
2. Turn on the computer, and when the boot screen shows up, press **F6** to initiate the Recovery Wizard.
3. The following screen shows the Recovery Wizard. Click **Recovery** button to continue.



4. A warning message about data loss will show up. Make sure the data is backed up before recovery, and click **Yes** to continue.





5. Wait the recovery process to complete. During the recovery process, a command prompt will show up to indicate the percent of recovery process complete. After complete the recovery process, the system will be turned off automatically. Please restart your system manually to complete the OS initialize process .

3.4 How to Enable Watchdog

To enable Watchdog, you need to download Winmate Watchdog utility. Find more information on Watchdog in “Watchdog Guide” that you can download from Winmate Download Center or File Share. Refer to the User Manual for more details.

To enable watchdog in Watchdog AP follow the instructions below:

1. On the right bottom side of the desktop screen, click  **triangle button** to show hidden icons.
2. Click  icon to open Watchdog utility.

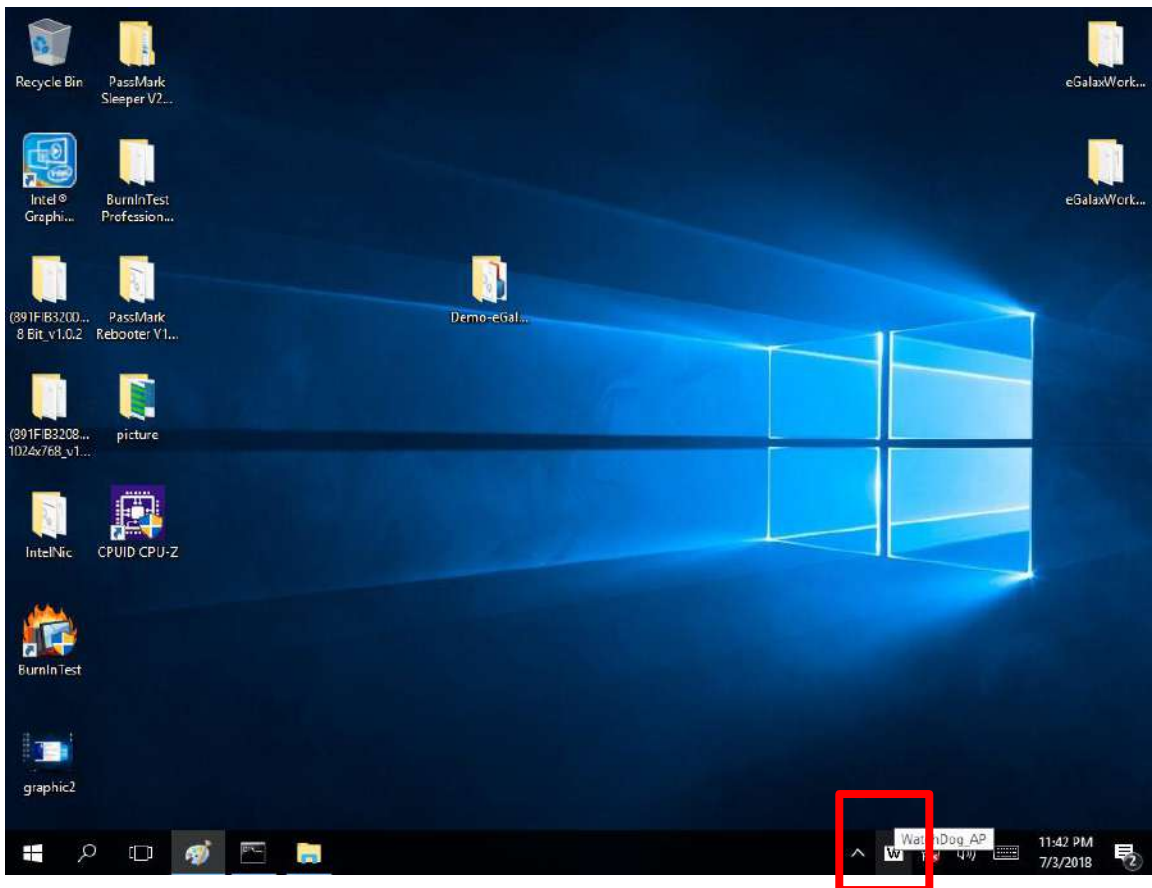

3. In Watchdog utility window set countdown time and periodically feed time, or disable watchdog.

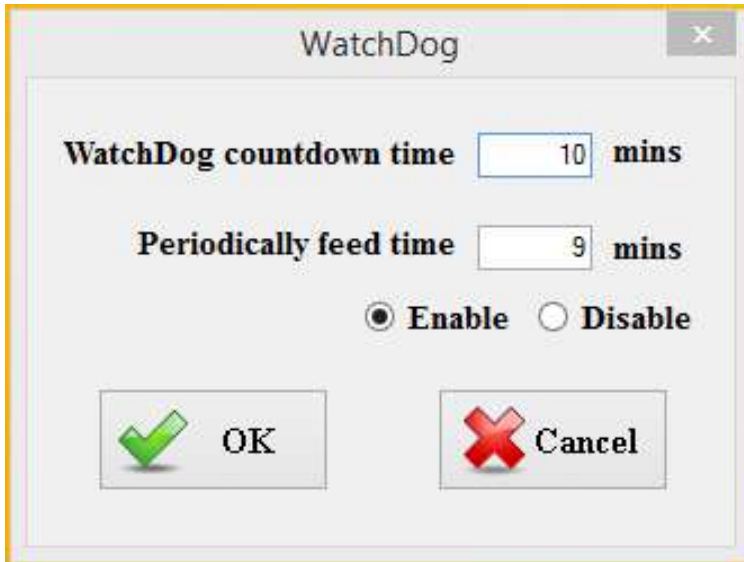

Example:

Every 10 min watchdog will monitor the system, in case any error occurs the system will restart automatically when the countdown time reaches 0.

Every 9 min watchdog timer will be reset to 10 min.

Setting	Description
Watchdog Countdown Time	The system automaticity restarts when this countdown time reaches zero. <i>Default: 10 min</i>
Periodically Feed Time	To set a cycle time to automatically reset watchdog timer. <i>Default: 9 min</i>
Enable / Disable	Enable or disable watchdog. <i>Default: Enable</i>

Chapter 4: Driver Installation

This chapter contains driver installation instructions for the IP32S 3.5" SBC.

- 4.1 Chipset Driver Installation
- 4.2 Graphics Driver Installation
- 4.3 Audio Driver Installation
- 4.4 LAN Driver Installation
- 4.5 TXE Driver Installation
- 4.6 Watchdog Driver Installation

4.1 Chipset Driver

Follow instructions below to install Chipset driver.

1. Open the Driver CD (included in the package) and select **Chipset** driver. When installation window will pop up, select **Next**.

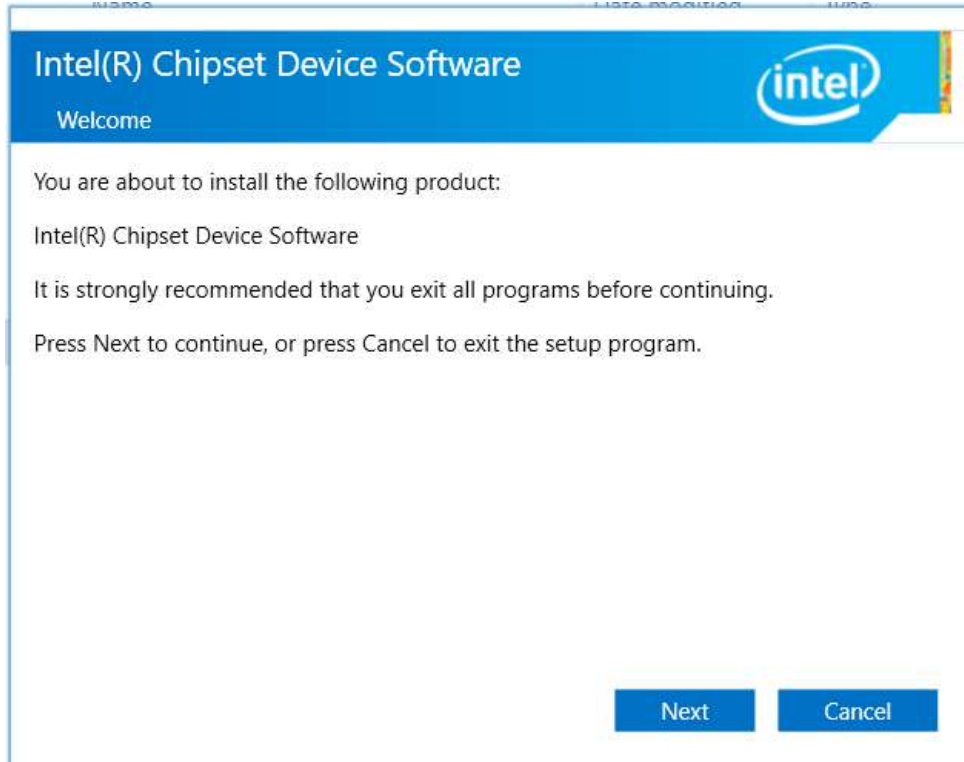

2. Select **Accept** to agree with the terms of license agreement.

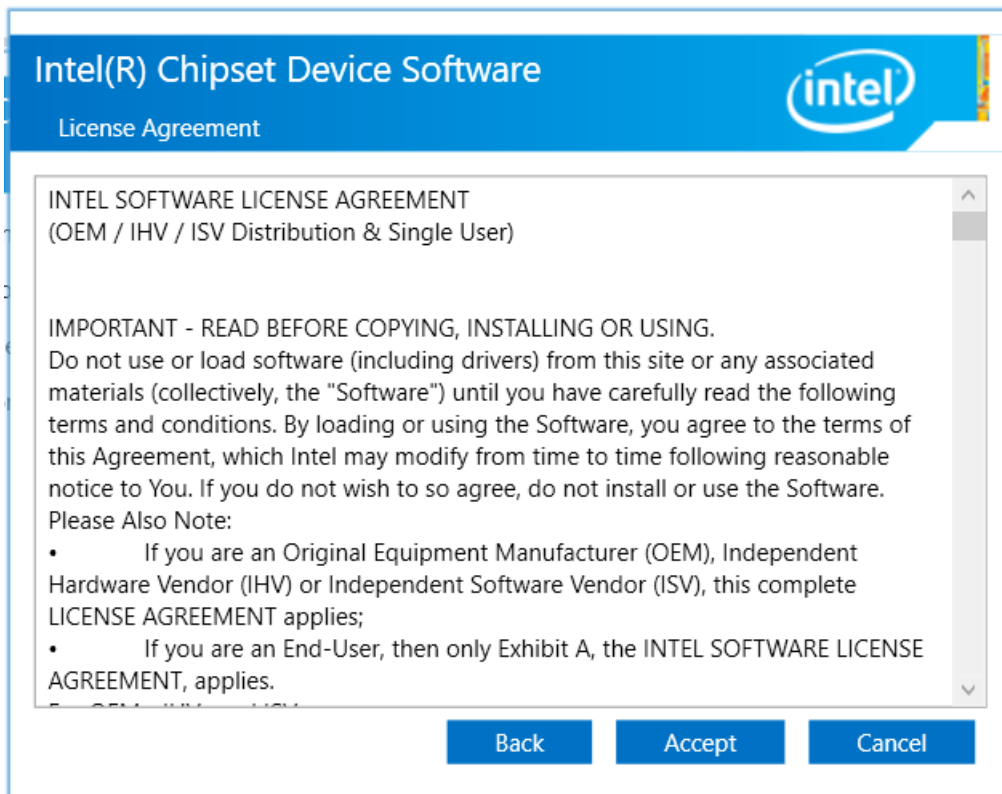

3. Check the ReadMe file information, select **Install** to continue.

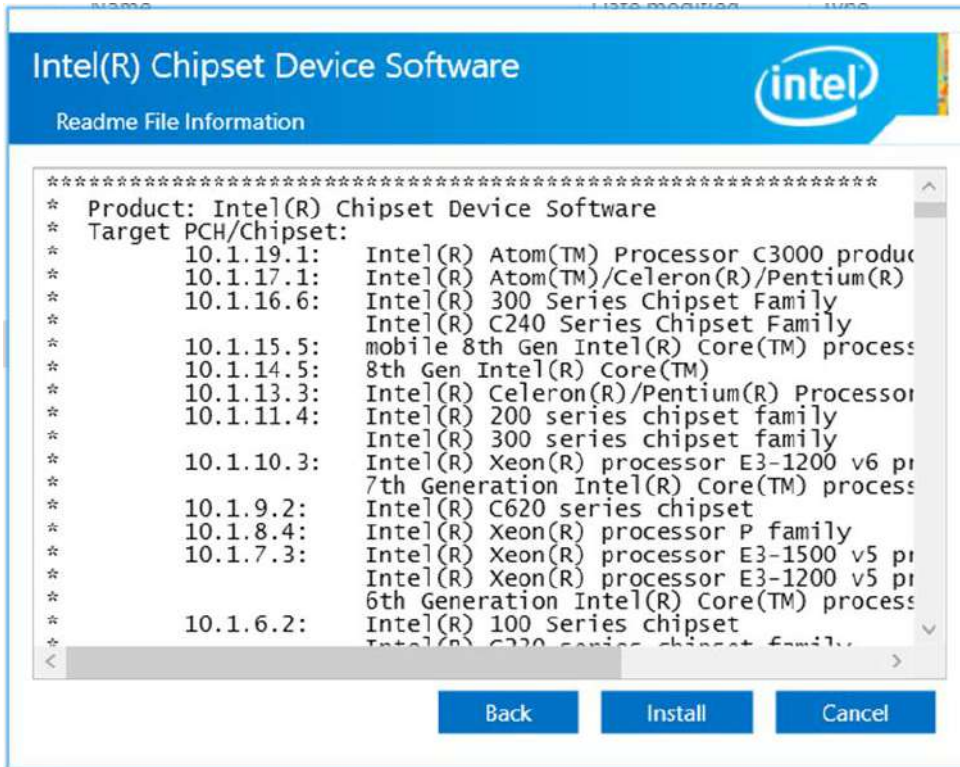

4. Wait for the driver to be installed. When installation completed, select **Finish** to exit installation window.

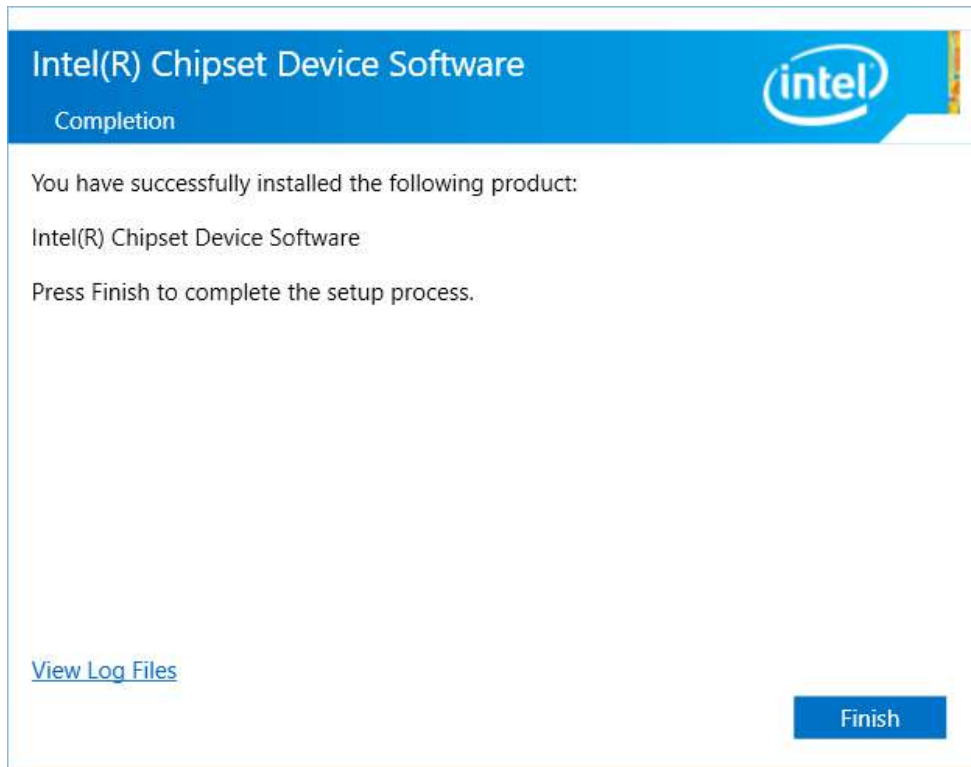

4.2 Graphics Driver

Follow instructions below to install Graphic driver.

1. Open the Driver CD (included in the package) and select **Graphics** driver. When installation window will pop up, select **Next**.

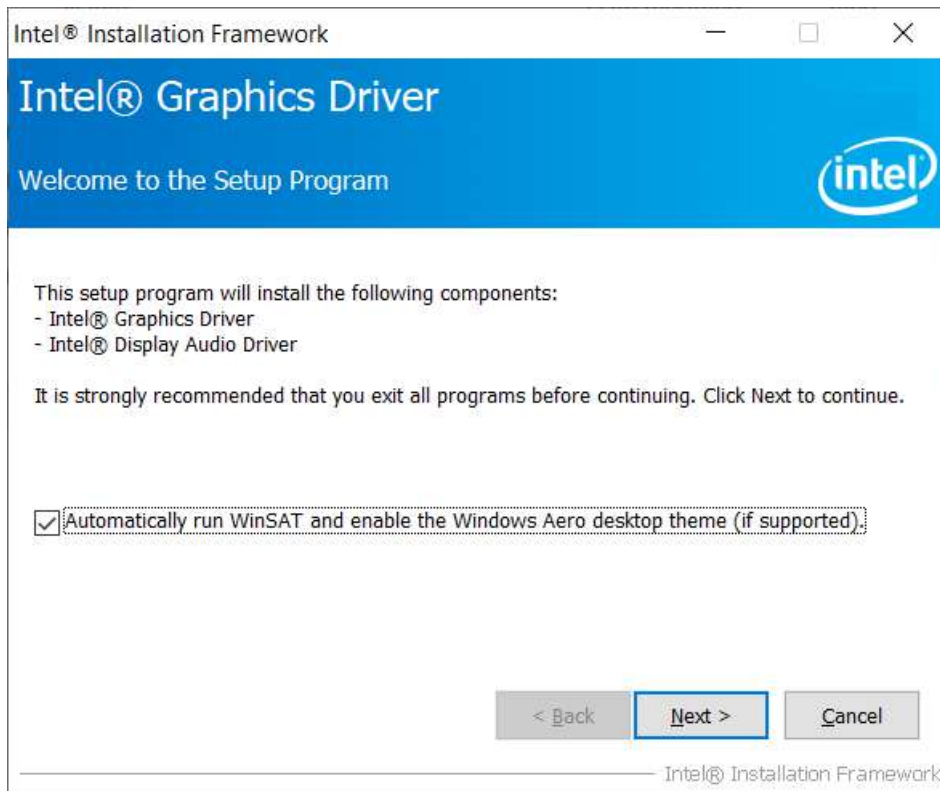

2. Select **Accept** to agree with the terms of license agreement.

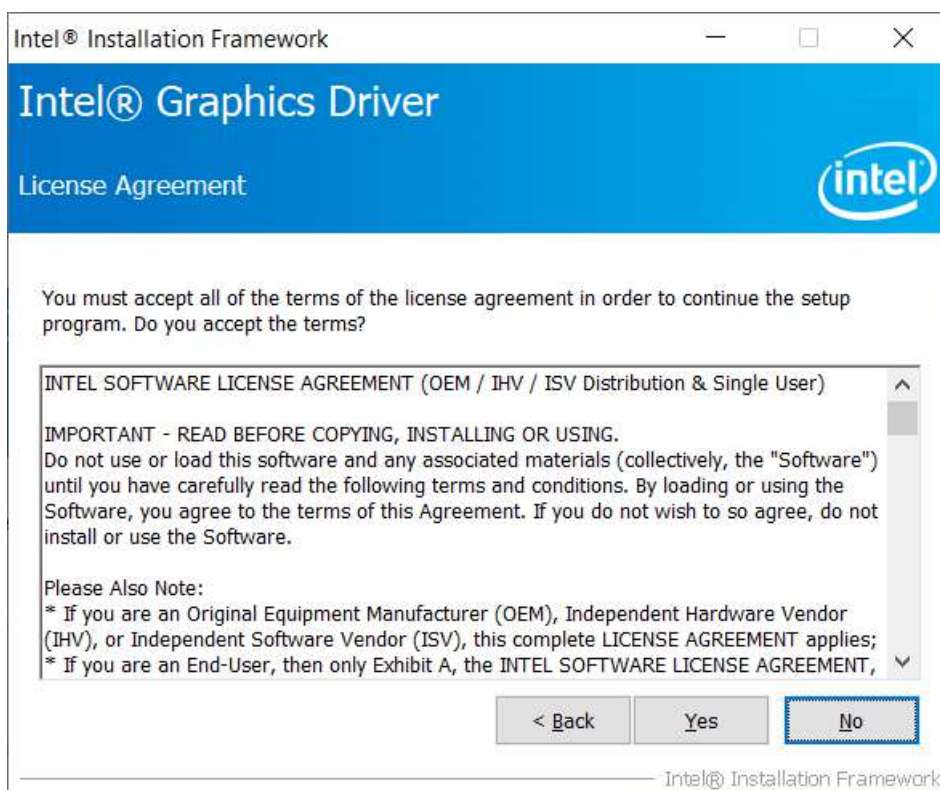

3. Check the ReadMe file information, select **Next** to continue.

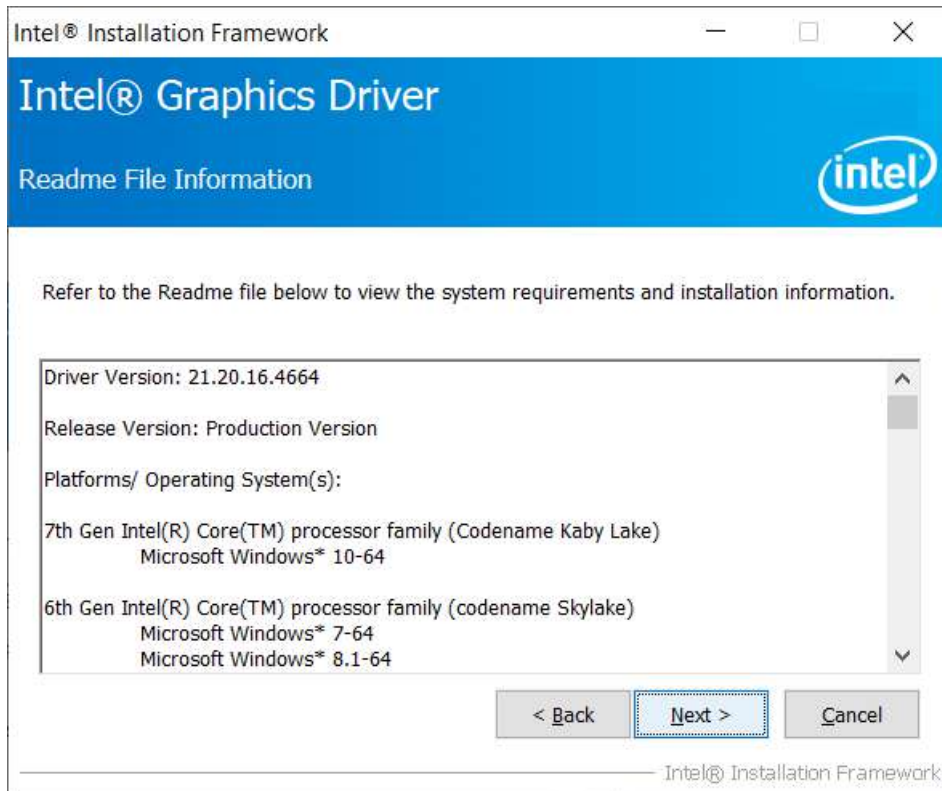

4. Wait for the driver to be installed.

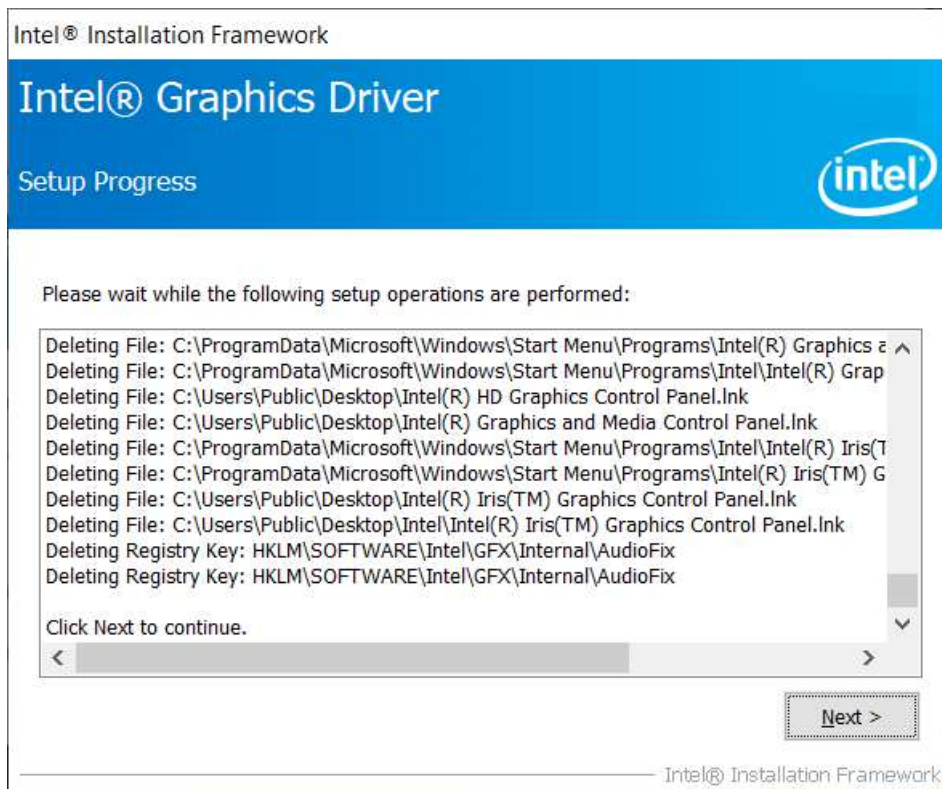

- When installation is completed, select “**Yes, I want to restart this computer now**”, and click **Finish**.

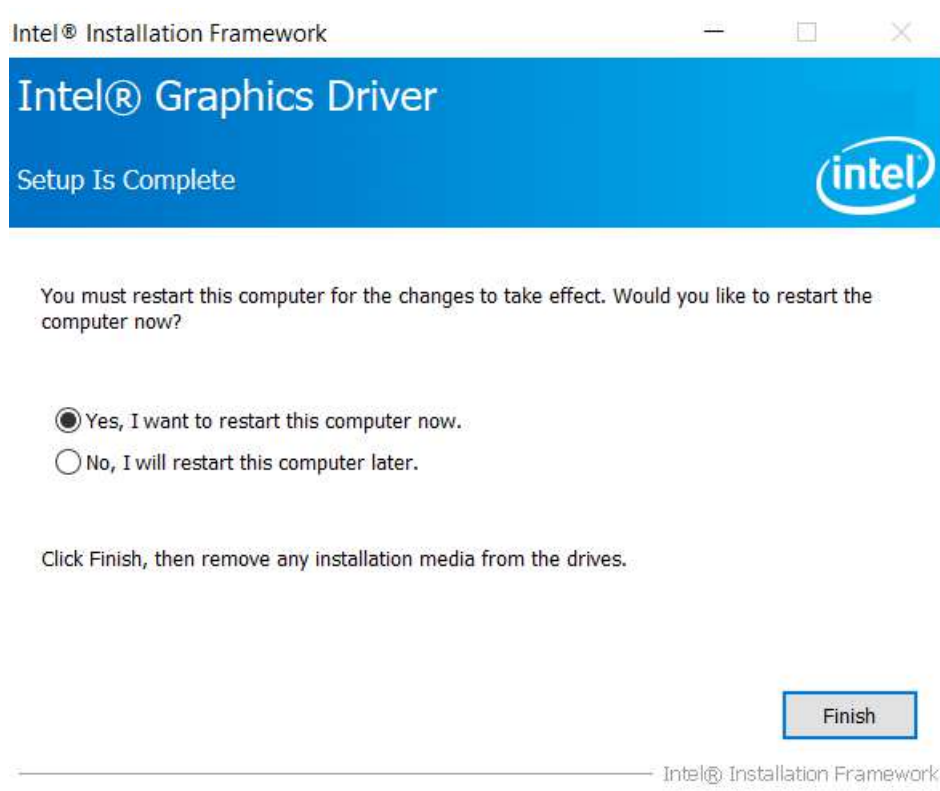

4.3 Audio Driver

Follow instructions below to install Audio Driver.

- Open the Driver CD (included in the package) and select **Audio** driver. When installation window will pop up, select **Next** to start the installation.



- When installation is completed, select “**Yes, I want to restart this computer now**”, and click **Finish**.



4.4 LAN Driver

Follow instructions below to install **LAN** driver.

1. Open the Driver CD (included in the package) and select **LAN** driver. When installation window will pop up, select **Next** to continue.

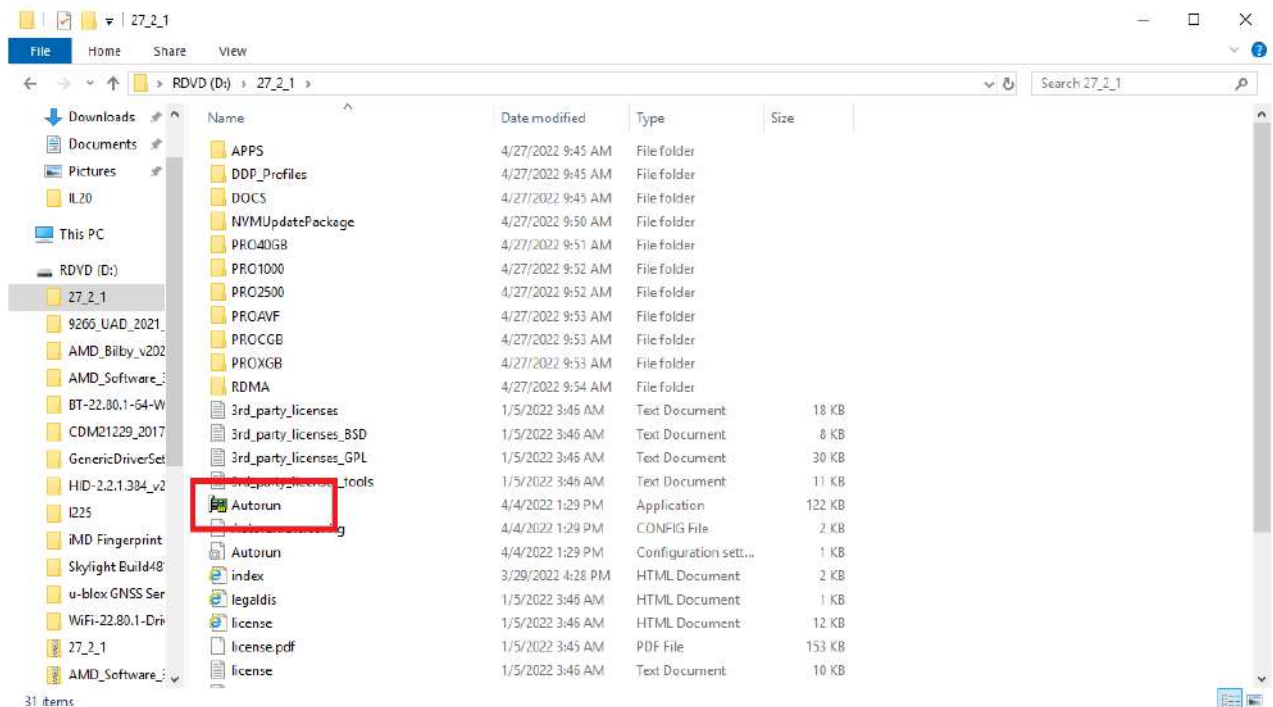

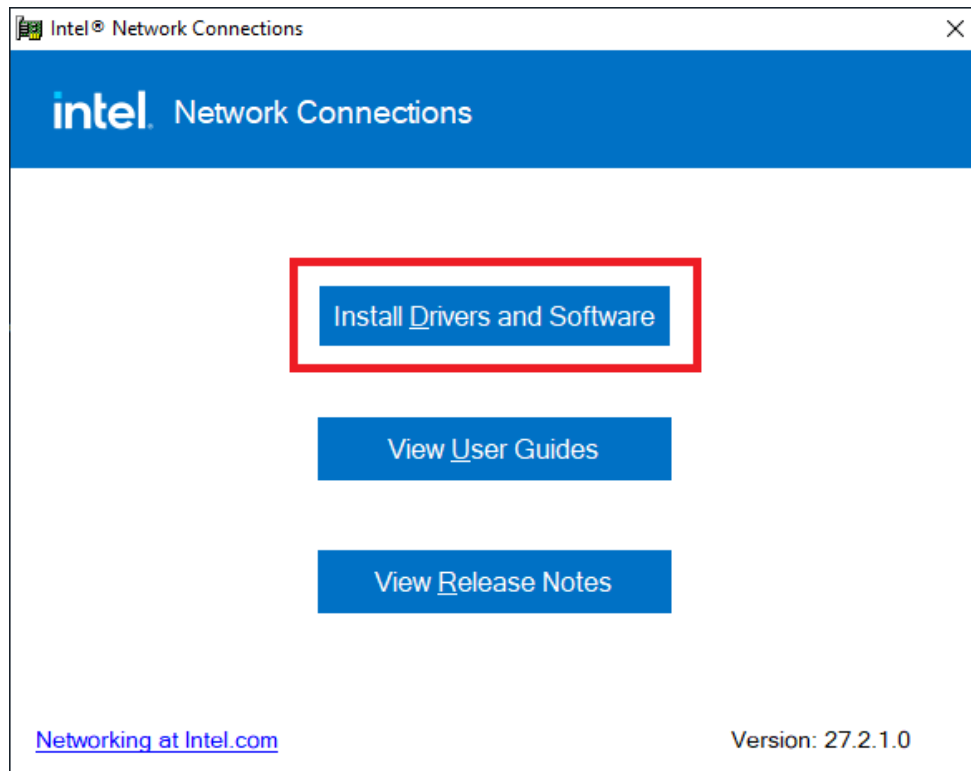
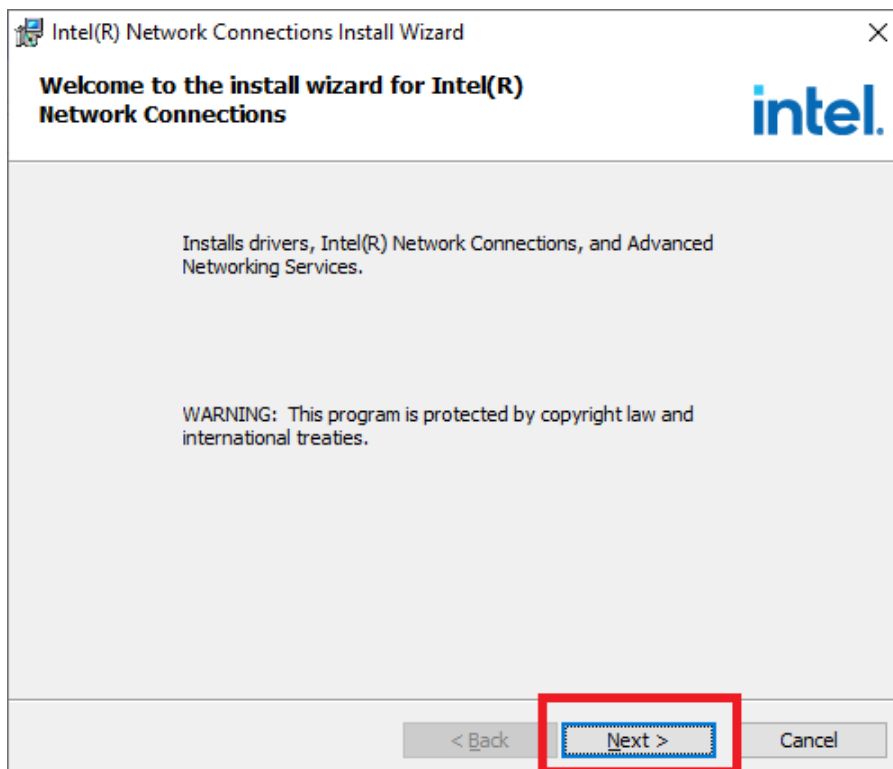
2. Click **Install Drivers and Software**.3. Click **Next**.

4. Choose **I accept the terms in the license agreement**, then click **Next**.



5. When installation is completed, select **Finish** to close the window.

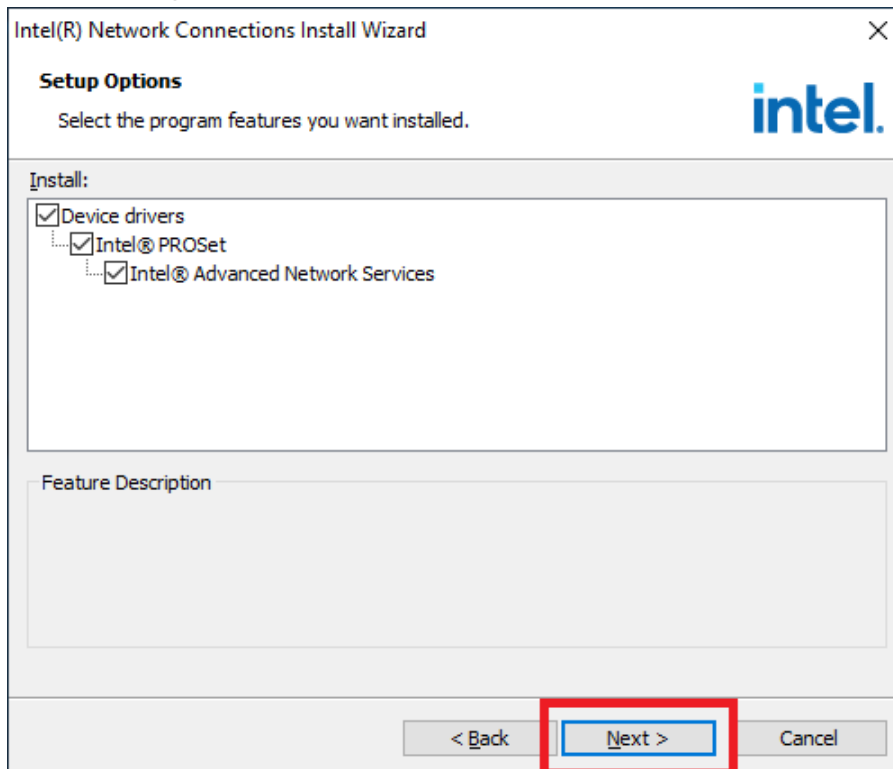

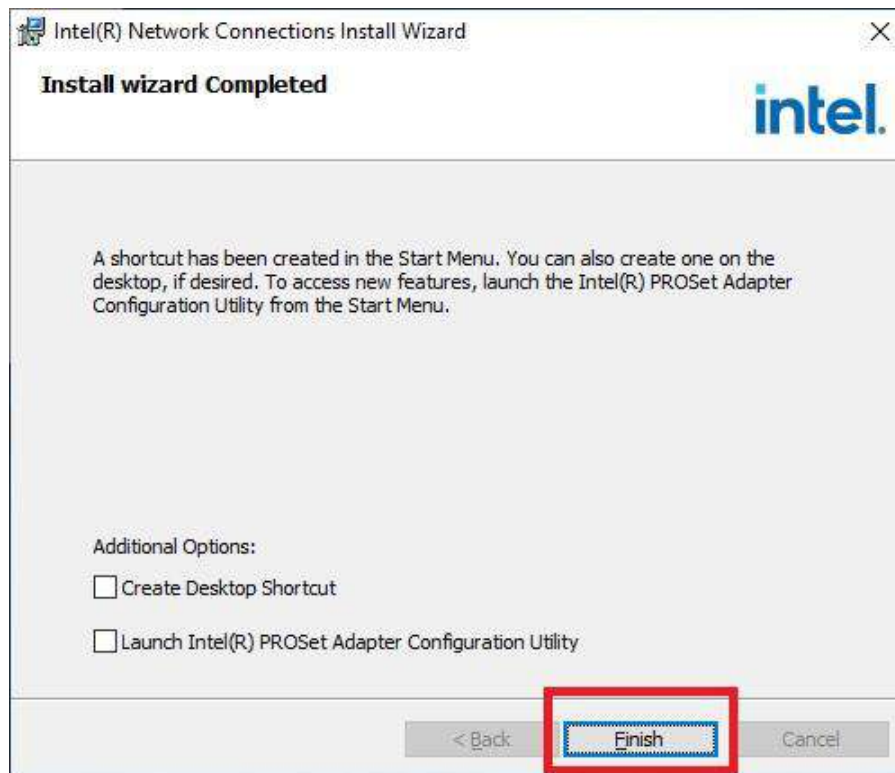

4.5 TXE Driver Installation

Follow instructions below to install **TXE** driver.

1. Open the Driver CD (included in the package) and select **TXE** driver. When installation window will pop up, select **Next** to start the installation.

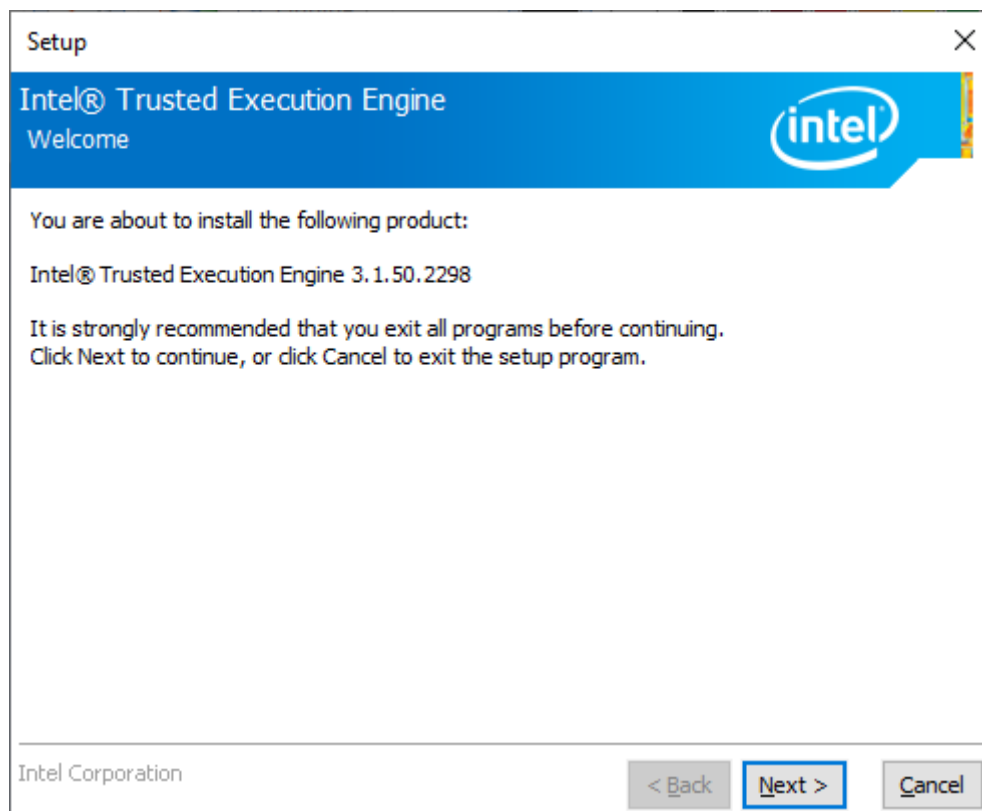

2. Read the license agreement, and then select **Next**.

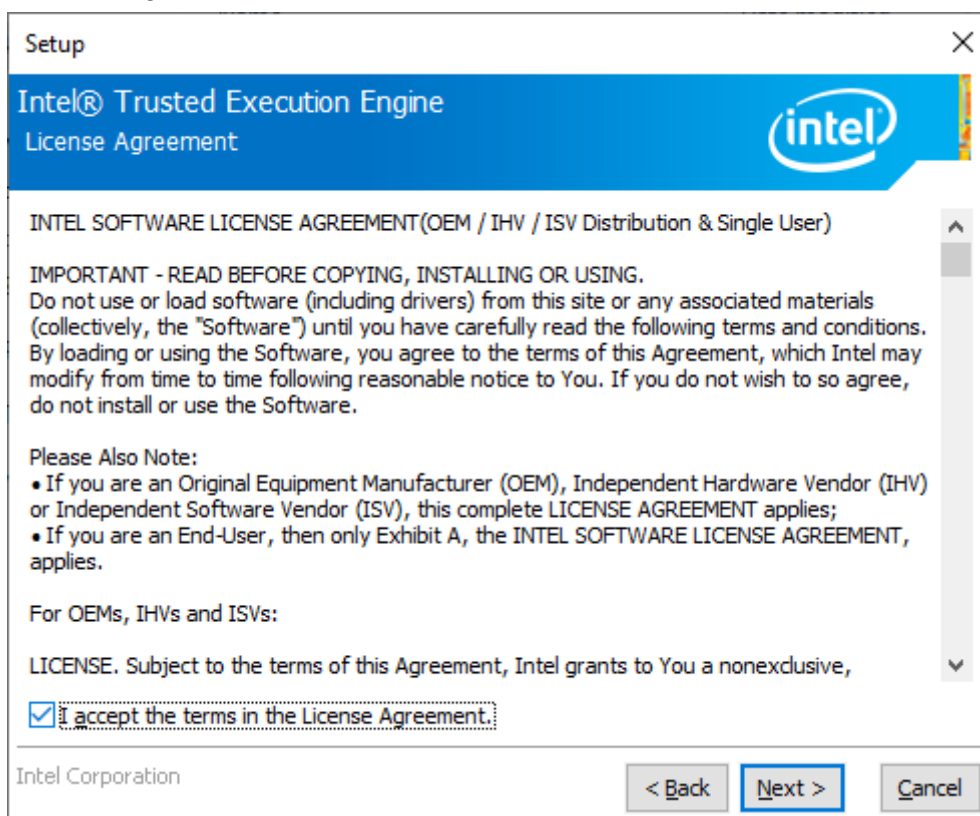

3. System displays the installed packages, select **Next**.

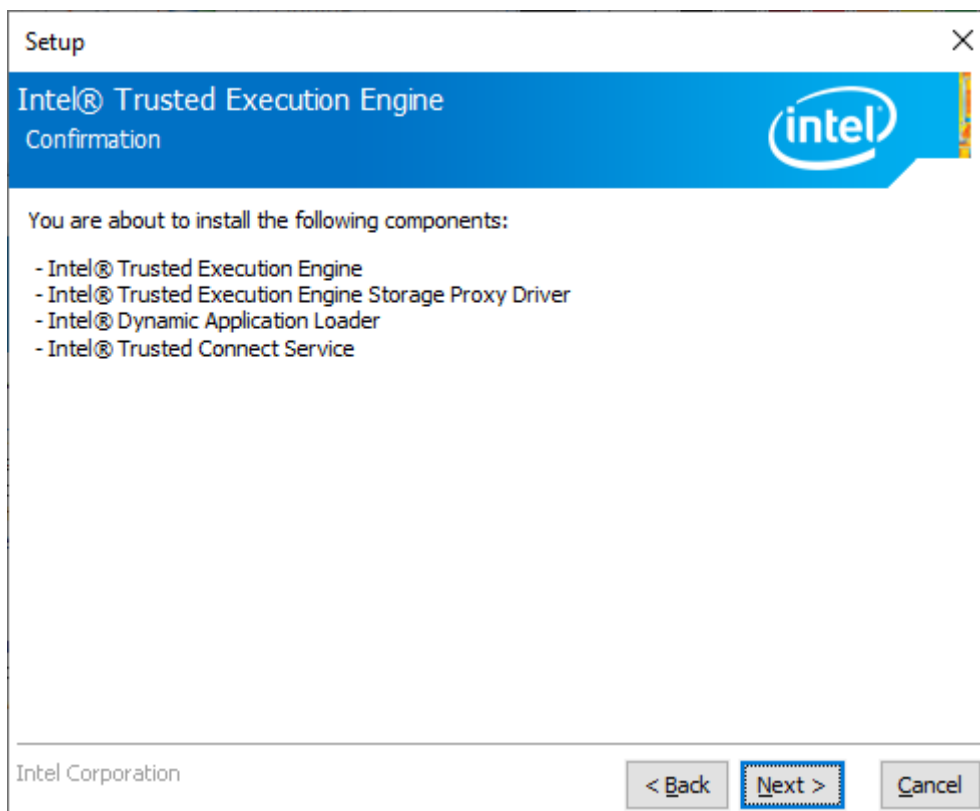

4. When installation is completed, select **Finish** to close the window.

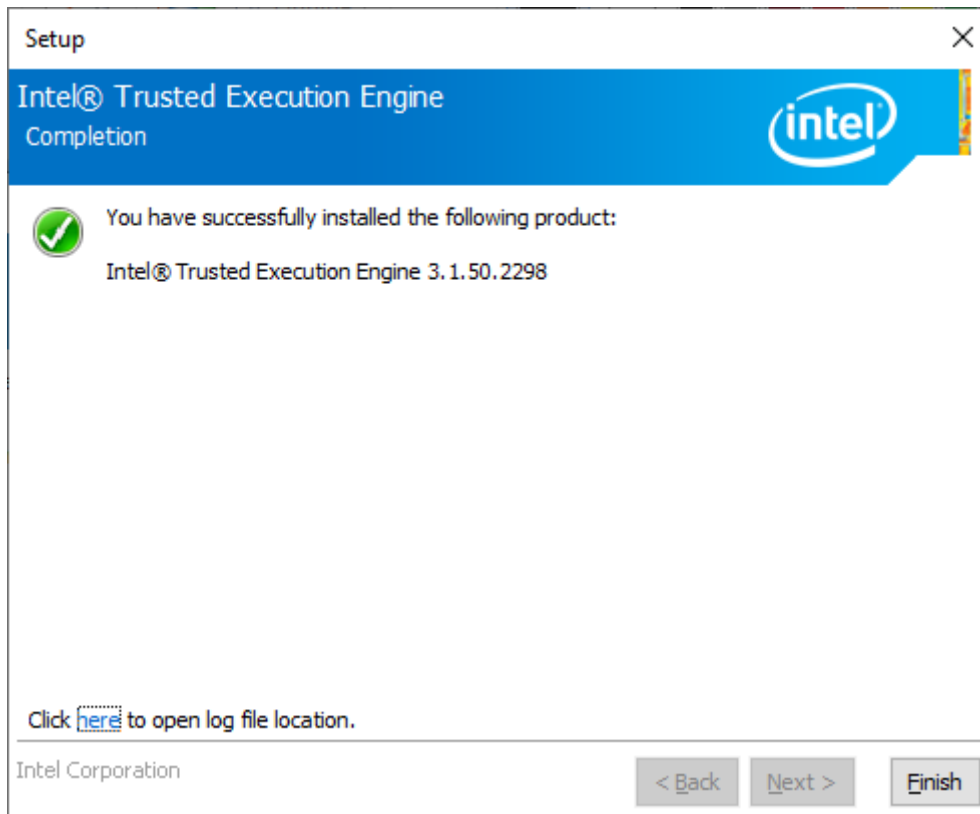

4.6 Watchdog Driver Installation

For more details about Winmate Watchdog, please download Watchdog Guide from Winmate Downloads Center [here](#).

Follow instructions below to install **Watchdog** driver.

1. Type “cmd” in the run box then the cmd.exe will appear in programs.

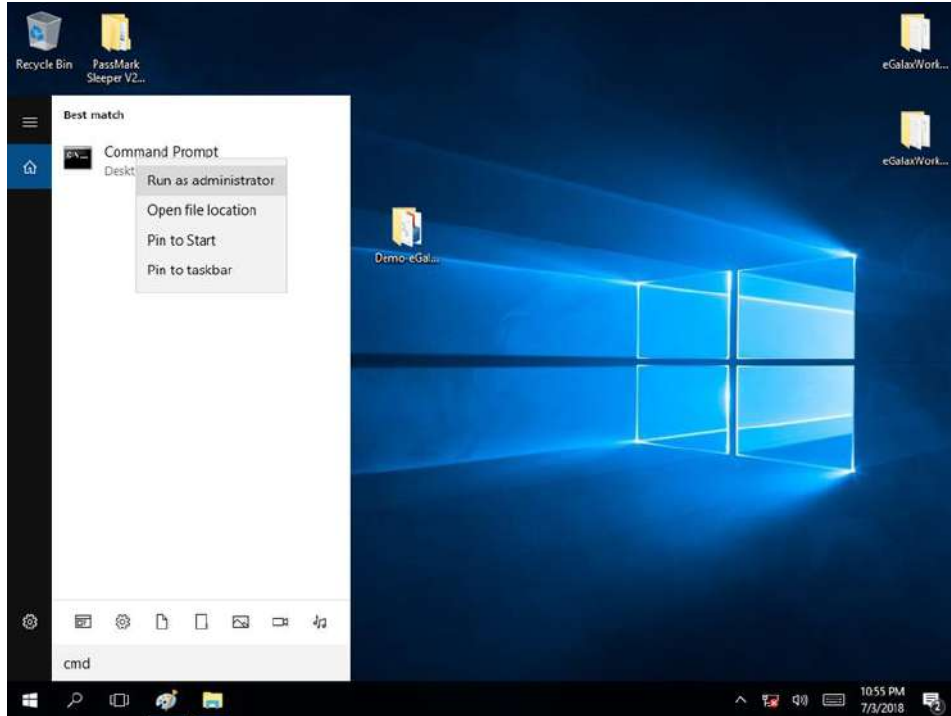

2. Right click on the cmd.exe and click on “Run as administrator” to start
3. Open the Driver CD (included in the package) and select Watchdog driver.

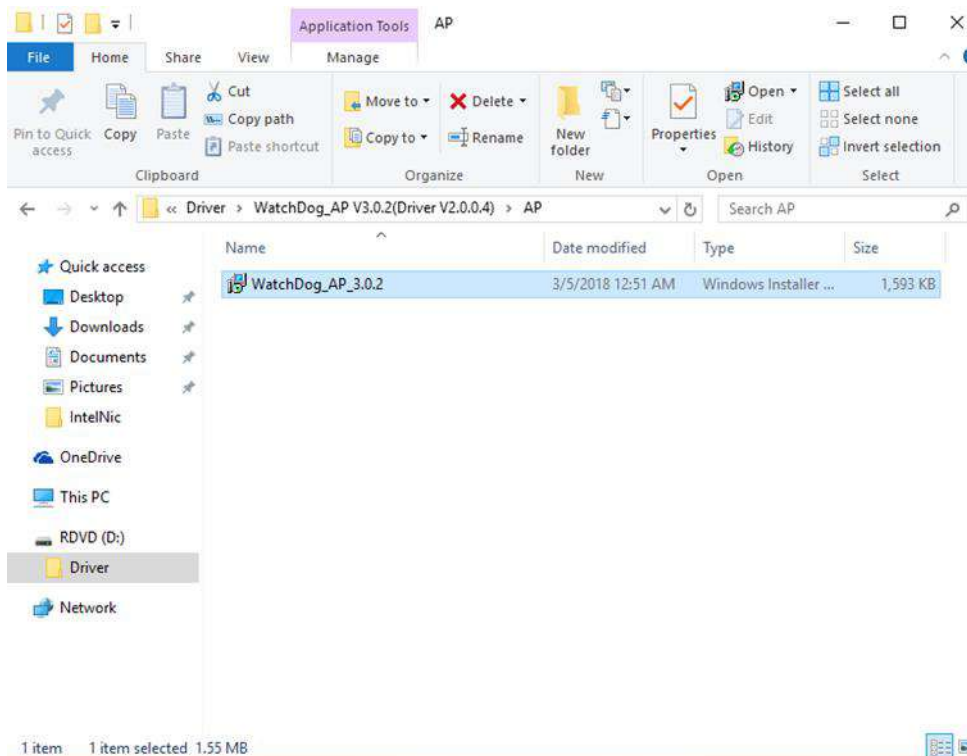

- When Windows Security dialog appear, select **install** to continue the Installation.

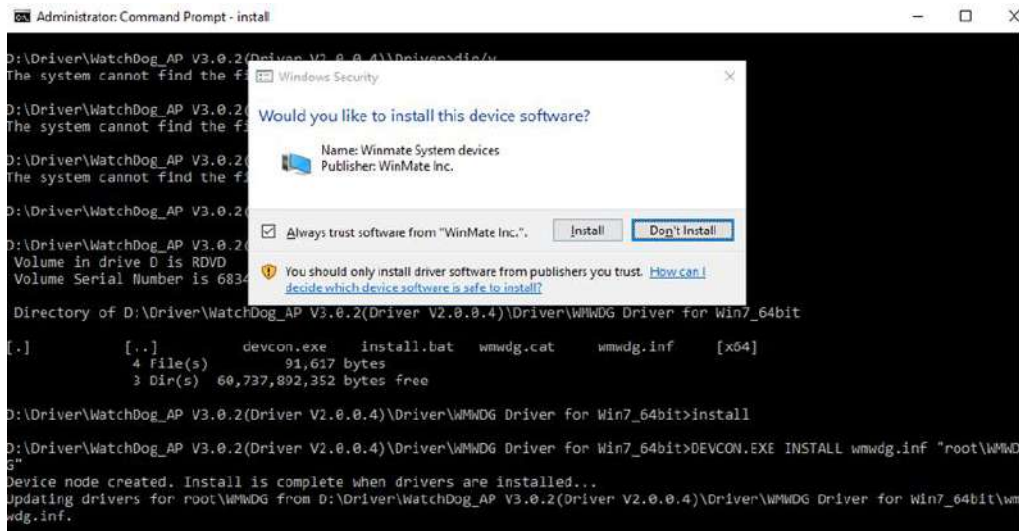

- Wait for installation to complete. When installation is complete, press any key to close.

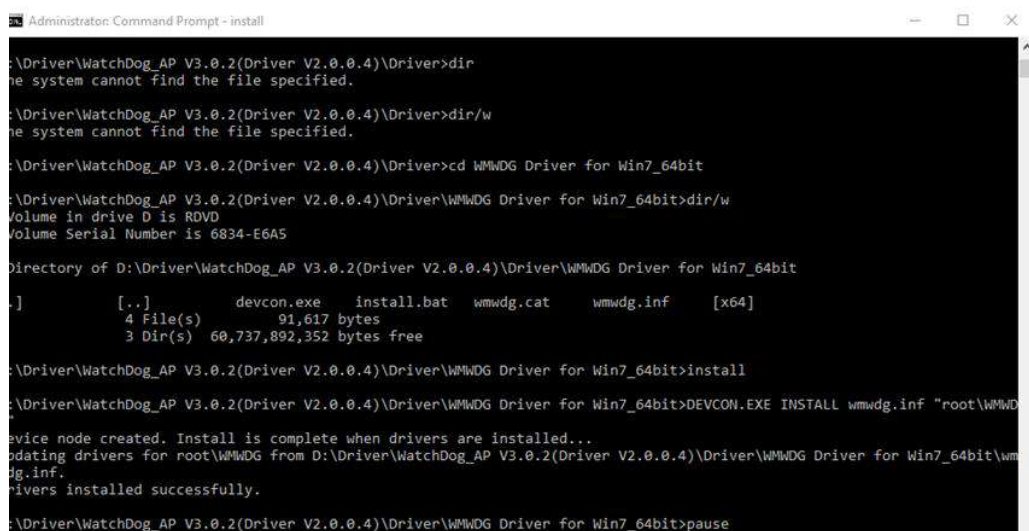

- Open the Driver CD (included in the package) and select **Watchdog AP**.

7. Select **Next**.



8. The installed storage location is displayed, select **Next** to continue.

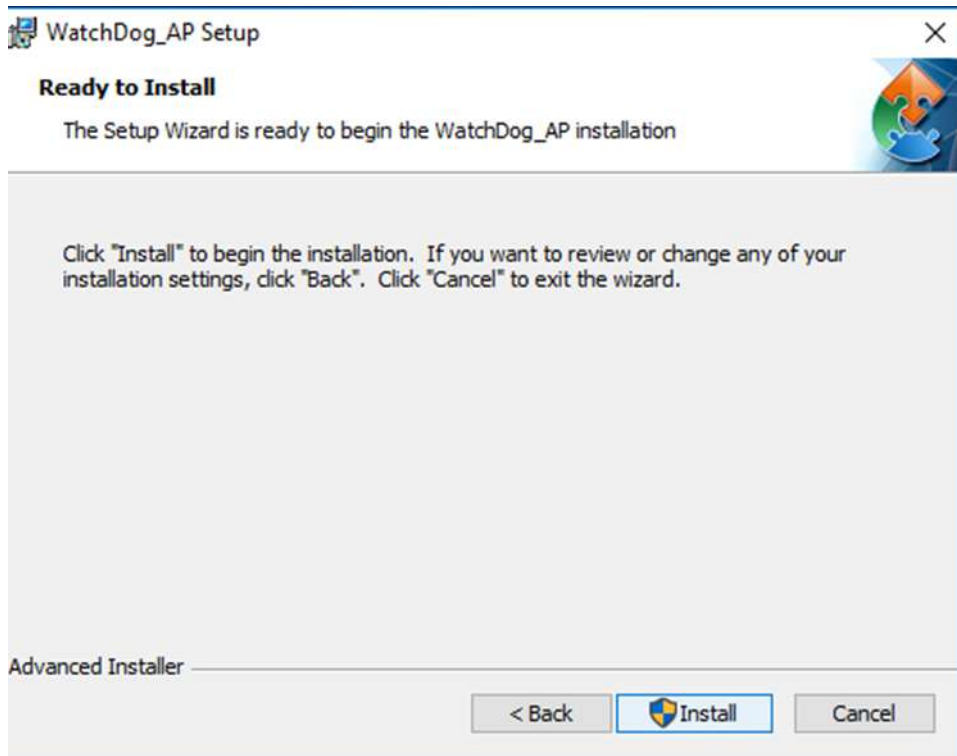

9. Select **Next** to start the installation.

10. When installation is completed, select **Finish** to close the window.



Chapter 5: Technical Support

This chapter contains directory to technical support.

5.1 Drivers

5.2 Software Development Kit (SDK)

5.1 Technical Support

Free technical support is available from our engineers every business day. We are always ready to give advice on application requirements or specific information on the installation and operation of any of our products. If any problem occurs immediately contact us.

5.2 Drivers

The list of drivers available for IP32S 3.5" SBC:

Item	Driver
1	Chipset Driver
2	Graphics Driver
3	Audio Driver
4	LAN Driver
5	TXE Driver
6	Watchdog Driver/AP
7	Digital IO Driver/AP

To find the Drivers, please refer to the Driver CD that comes in the package or contact us.

5.3 Software Development Kit (SDK)

The list of SDK available for IP32S 3.5" SBC.

Item	File Type	Description
1	SDK	Watchdog SDK
2	SDK	DIDO SDK

To find the SDK, please refer to the Driver CD that comes in the package or contact us.



Winmate Inc.
9F, No.111-6, Shing-De Rd., San-Chung District,
New Taipei City 24158, Taiwan, R.O.C
www.winmate.com



Copyright © Winmate Inc. All rights reserved.