

# IE32 3.5" SBC

**3.5" Form Factor SBC with Intel® Celeron® N6211 1.2GHz (up to 3.00 GHz),  
HDMI, eDP, LVDS, USB 3.2 Gen2 x1, SATA III, and M.2 Interface**

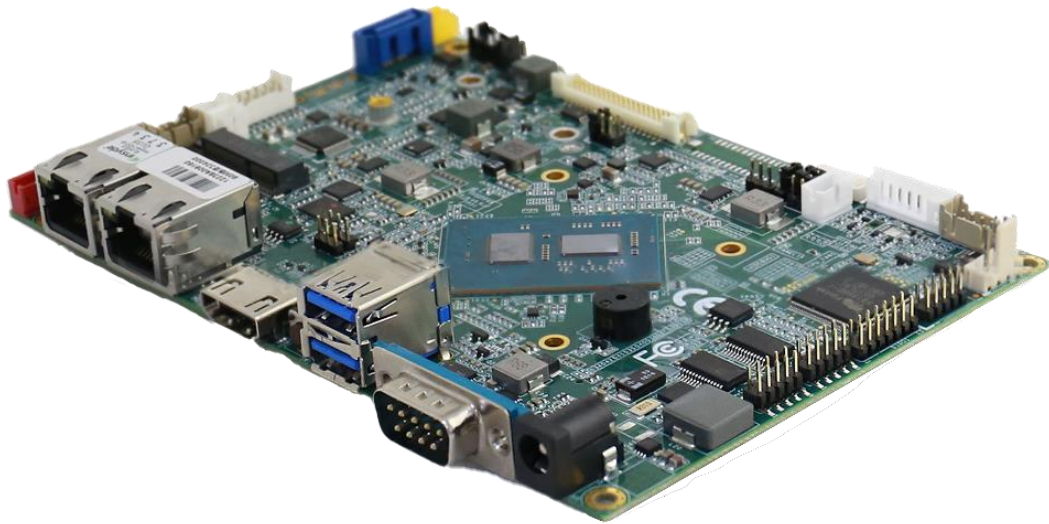

---

# User Manual

# Contents

<b>PREFACE .....</b>	<b>3</b>
<b>ABOUT THIS USER MANUAL .....</b>	<b>6</b>
<b>CHAPTER 1: GENERAL INFORMATION .....</b>	<b>7</b>
1.1 INTRODUCTION .....	8
1.2 FEATURES.....	8
1.3 MOTHERBOARD SPECIFICATIONS.....	9
1.4 FUNCTIONAL DESCRIPTION .....	11
1.5 PHYSICAL DESCRIPTION.....	12
<b>CHAPTER 2: HARDWARE INSTALLATION .....</b>	<b>13</b>
2.1 MOTHERBOARD COMPONENTS .....	14
2.2 MEMORY MODULE (SO-DIMM) INSTALLATION.....	16
2.3 I/O EQUIPMENT INSTALLATION .....	17
2.3.1 Power Input 12V DC in.....	17
2.3.2 Serial COM Port .....	17
2.3.3 HDMI .....	17
2.3.4 Ethernet Interface.....	17
2.3.5 USB Port.....	17
2.3.6 Audio .....	17
2.4 JUMPER SETTINGS .....	18
2.4.1 JP1: Backlight Power Voltage Select .....	19
2.4.2 JP2: PWM/DC Mode Select.....	19
2.4.3 JP3: Panel Power Voltage Select .....	19
2.4.4 JP4: Brightness PWM Control Select.....	19
2.5.1 External I/O Side Connectors .....	20
2.5.2 Internal I/O Side Connectors.....	22
<b>CHAPTER 3: INSYDE H20 BIOS SETUP .....</b>	<b>29</b>
3.1 MAIN MENU .....	30
3.2 Advanced .....	31
3.2.13 Security .....	45
3.2.14 Power.....	46
3.2.15 Exit.....	46
3.3 USING RECOVERY WIZARD TO RESTORE COMPUTER .....	47
<b>CHAPTER 4: DRIVER INSTALLATION .....</b>	<b>48</b>
4.1 CHIPSET DRIVER.....	49
4.2 GRAPHIC DRIVER .....	51

4.3 MANAGEMENT ENGINE (ME).....	54
4.4 SST DRIVER .....	57
4.5 AUDIO DRIVER.....	60
4.6 ETHERNET DRIVER .....	62
4.7 WATCHDOG DRIVER.....	66
4.8 HOW TO ENABLE WATCHDOG .....	71
4.9 DIGITAL IO DRIVER .....	73
4.10 RESISTIVE TOUCH DRIVER FOR WINDOWS 11 SYSTEM .....	75
<b>CHAPTER 5: TECHNICAL SUPPORT .....</b>	<b>78</b>
5.1 DRIVERS .....	79
5.2 SOFTWARE DEVELOPMENT KIT (SDK).....	79

# Preface

## Copyright Notice

No part of this document may be reproduced, copied, translated, or transmitted in any form or by any means, electronic or mechanical, for any purpose, without the prior written permission of the original manufacturer.

## Trademark Acknowledgement

Brand and product names are trademarks or registered trademarks of their respective owners.

## Disclaimer

We reserve the right to make changes, without notice, to any product, including circuits and/or software described or contained in this manual in order to improve design and/or performance. We assume no responsibility or liability for the use of the described product(s), conveys no license or title under any patent, copyright, or masks work rights to these products, and makes no representations or warranties that these products are free from patent, copyright, or mask work right infringement, unless otherwise specified. Applications that are described in this manual are for illustration purposes only. We make no representation or warranty that such application will be suitable for the specified use without further testing or modification.

## Warranty

We warrant that each of its products will be free from material and workmanship defects for a period of one year from the invoice date. (Standard is one year, extended warranty will need to discuss with our sales representatives. If the customer discovers a defect, we will, at its option, repair or replace the defective product at no charge to the customer, provided it is returned during the warranty period of one year, with transportation charges prepaid. The returned product must be properly packaged in its original packaging to obtain warranty service.

If the serial number and the product shipping data differ by over 30 days, the in-warranty service will be made according to the shipping date. In the serial numbers the third and fourth two digits give the year of manufacture, and the fifth digit means the month (e. g., with A for October, B for November and C for December).

For example, the serial number 1W19Axxxxxxx means October of year 2019.

## Packing List

Before using this Motherboard, please make sure that all the items listed below are present in your package:

- IE32 3.5" SBC

If any of these items are missing or damaged, contact your distributor or sales representative immediately.

## Customer Service

We provide a service guide as below for any problem by the following steps: First, contact your distributor, sales representative, or our customer service center for technical support if you need additional assistance.

You need to prepare the following information before you call:

- Product serial number
- Peripheral attachments
- Software (OS, version, application software, etc.)
- Detailed problem description
- The exact wording of any error messages

In addition, free technical support is available from our engineers every business day. We are always ready to give advice on application requirements or specific information on the installation and operation of any of our products. Please do not hesitate to call or e-mail us.

## Advisory Conventions

Four types of advisories are used throughout the user manual to provide helpful information or to alert you to the potential for hardware damage or personal injury. These are Notes, Important, Cautions, and Warnings. The following is an example of each type of advisory.

**NOTE:**

A note is used to emphasize helpful information

**IMPORTANT:**

An important note indicates information that is important for you to know.

**CAUTION**

A Caution alert indicates potential damage to hardware and explains how to avoid the potential problem.

**WARNING!**

An Electrical Shock Warning indicates the potential harm from electrical hazards and how to avoid the potential problem.

## Safety Precautions



### CAUTION

Always ground yourself to remove any static charge before touching the CPU card. Modern electronic devices are very sensitive to static electric charges. As a safety precaution, use a grounding wrist strap at all times. Place all electronic components in a static-dissipative surface or static-shielded bag when they are not in the chassis.

## Safety and Warranty

1. Please read these safety instructions carefully.
2. Please keep this user manual for later reference.
3. Please disconnect this equipment from any AC outlet before cleaning. Do not use liquid or spray detergents for cleaning. Use a damp cloth.
4. For pluggable equipment, the power outlet must be installed near the equipment and must be easily accessible.
5. Keep this equipment away from humidity.
6. Put this equipment on a reliable surface during installation. Dropping it or letting it fall could cause damage.
7. Make sure the voltage of the power source is correct before connecting the equipment to the power outlet.
8. Position the power cord so that people cannot step on it. Do not place anything over the power cord.
9. All cautions and warnings on the equipment should be noted.
10. If the equipment is not used for a long time, disconnect it from the power source to avoid damage by transient over-voltage.
11. If any of the following situations arises, get the equipment checked by service personnel:
  - A. The power cord or plug is damaged.
  - B. Liquid has penetrated into the equipment.
  - C. The equipment has been exposed to moisture.
  - D. The equipment does not work well, or you cannot get it to work according to the user's manual.
  - E. The equipment has been dropped and damaged.
  - F. The equipment has obvious signs of breakage.

## About This User Manual

This User Manual provides information about using the IE32 3.5" SBC. The documentation set for the IE32 3.5" SBC provides information for specific user needs, and includes:

- **IE32 3.5" SBC User Manual** – contains detailed description on how to use the motherboard, its components and features.



**NOTE:**

Some pictures in this guide are samples and can differ from actual product.

# Chapter 1: General Information

This chapter includes the IE32 3.5" SBC background information.

- 1.1 Introduction
- 1.2 Features
- 1.3 Motherboard Specifications
- 1.4 Functional Description
- 1.5 Physical Description



## 1.1 Introduction

Thank you for choosing the IE32 3.5" SBC. This motherboard can be integrated with Intel® Celeron® Processor N6211 1.2GHz (up to 3.00 GHz), with low power consumption. The IE32 3.5" SBC supports 260-pin DDR4-3200 non-ECC SO-DIMM RAM, up to 16 GB.

There is an advanced full set of I/O ports including 1 x SATA III, 3 x COM, 2 x USB 3.2 Gen2 x1 (10Gbps), 4 x USB 2.0. The motherboard is designed in 3.5" form factor and measures 146mm x 102mm.

Abundant I/O connectors and expandability makes the IE32 3.5" SBC to be the right fit in the majority of industrial computer applications such as machine vision and control, gaming, POS, KIOSK systems, industrial automation, and others. Powerful processor in 3.5" form-factor meets the demanding performance requirements of modern industrial applications.

## 1.2 Features

IE32 3.5" SBC features:

- 3.5" Form Factor (146mm x 102mm)
- Intel® Celeron® Processor N6211 1.2GHz (up to 3.00 GHz)
- One DDR4-3200 SO-DIMM RAM
- 2 x Intel Gigabit Ethernet
- 1 x SATA III, 3 x COM, 2 x USB 3.2 Gen2 x1, 4 x USB 2.0
- 1 x M.2 2242 B-Key SSD, up to 512GB

## 1.3 Motherboard Specifications

		Model Name
		IE32 3.5" SBC
<b>System Specifications</b>	CPU	Intel® Celeron® Processor N6211 1.2GHz (up to 3.00GHz)
	System Memory	1 x DDR4-3200 non-ECC SO-DIMM RAM, up to 16GB
	Storage	1 x M.2 2242 B-key SSD up to 512GB 1 x SATA III for 2.5" SSD/HDD up to 1TB (Optional)
	BIOS	Insyde H20 BIOS
	Graphic Controller	Intel® UHD Graphics
	Graphic Resolution	HDMI Mode:HDMI 2.0b/ 4096x2160@ 60Hz eDP Mode: eDP 1.3/4096x2160@ 60Hz
<b>Display Specifications</b>	Audio Codec	Realtek HD Audio Codec
<b>Audio</b>	Audio Interface	Mic-in / Line-in / Line-out
<b>Ethernet</b>	Ethernet Controller	Intel Gigabit-LAN Controller x 2
<b>I/O Ports Specification</b>	Rear I/O	2 x RJ-45 1 x RS-232/RS422/RS485 (Default RS232) 2 x USB 3.2 Gen 2 x1 (10Gbps) 1 x HDMI 2.0b (Optional) 1 x DC-in Power Jack (+12V)
	Internal I/O	1 x eDP / 30-pin(2x15) DF-13 connector 1 x LVDS / 40-pin(2x20) DF-13 connector 1 x SATA III connector 1 x SATA Power connector 4 x USB 2.0 1 x Digital I/O(12-bit GPIO) / 14-pin(2x7) 1 x Power-input / 6-pin 1 x +12V for external power(Yellow) / 2-pin 1 x +5V for external power(Red) / 2-pin 1 x +3.3V for external power(Blue) / 2-pin 1 x Fan / 3-pin 1 x Brightness control / 3-pin 1 x VR/Software brightness switch jumper/ 3-pin 1 x PWM/DA brightness switch jumper / 3-pin 1 x 3.3V/5V PWM Level switch jumper / 3-pin 1 x Panel Inverter / 7-pin 1 x Front Panel / 10-pin(2x5) 2 x Speaker with Amp. / 2-pin 1 x Audio (Mic-in / Line-in / Line-out) / 12-pin(2x6) 1 x RTC Battery / 2-pin 2 x COM Ports / 2x 5 pin Headers
	Expansions Slot	1 x M.2 Key E Slot (for Wireless Module)
<b>Mechanical Specifications</b>	Dimensions	146 mm x 102 mm / 5.7 x 4 inches (3.5" Form Factor)
<b>Environment</b>	Operating Temp.	0°C ~ 50°C

<b>Considerations</b>	Storage Temp.	-20°C ~ 60°C
	Humidity	10~95% RH@40°C, non-condensing
<b>Power Management</b>	Power Requirement	12V 2.5φ DC-IN Power Jack
	Power Consumption	24W (Max)
<b>Operating System</b>	OS	Windows 11 IoT Enterprise (Optional) Windows 10 IoT Enterprise (Optional) Linux Ubuntu 22.04 (Optional)
<b>Packing List</b>	Standard	IE32 Single Board Computer IE32 Manual

# 1.4 Functional Description

## IE32 3.5" SBC Function block

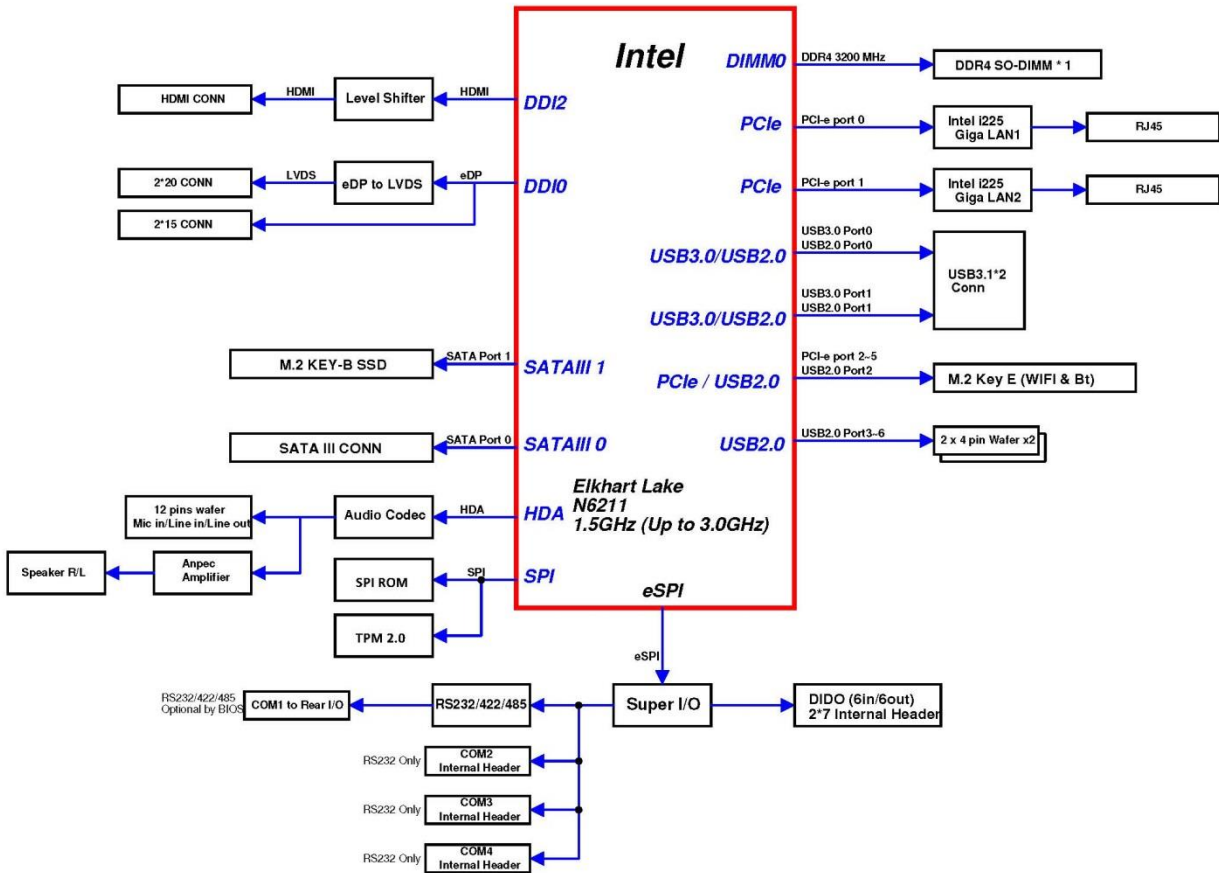

## 1.5 Physical Description

### IE32 3.5" SBC Board Dimensions

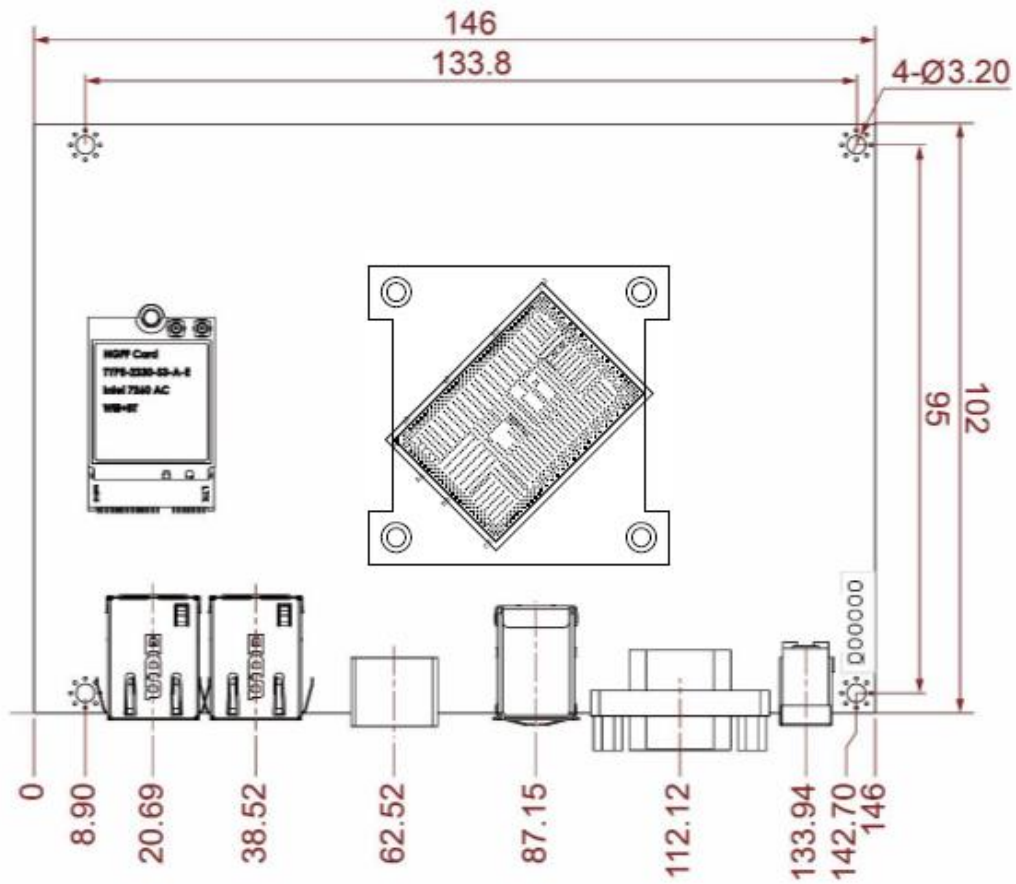

## Chapter 2: Hardware Installation

This chapter provides information on how to use jumpers and connectors on the IE32 3.5" SBC. Be cautious while working with these modules. Carefully read the content of this chapter in order to avoid any damages.

- 2.1 Motherboard Components
  - 2.2 Memory Module Installation
  - 2.3 I/O Equipment Installation
  - 2.4 Jumper Settings
  - 2.5 Motherboard Connectors
-

## 2.1 Motherboard Components

### 2.1.1 Top side

IE32 3.5" SBC Top Layer (Top View)

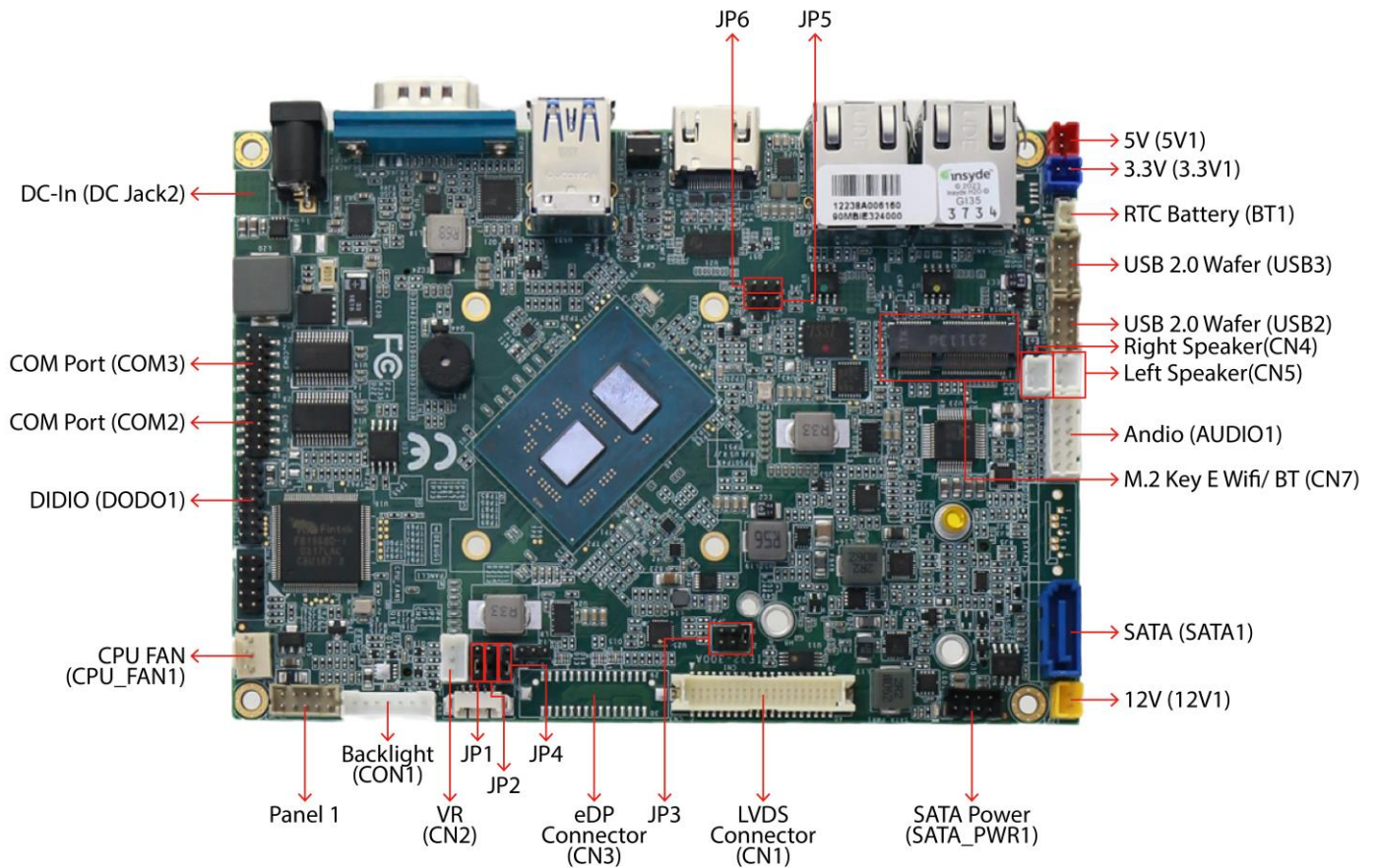

### 2.1.2 Bottom side

IE32 3.5" SBC Bottom Layer (Top View)

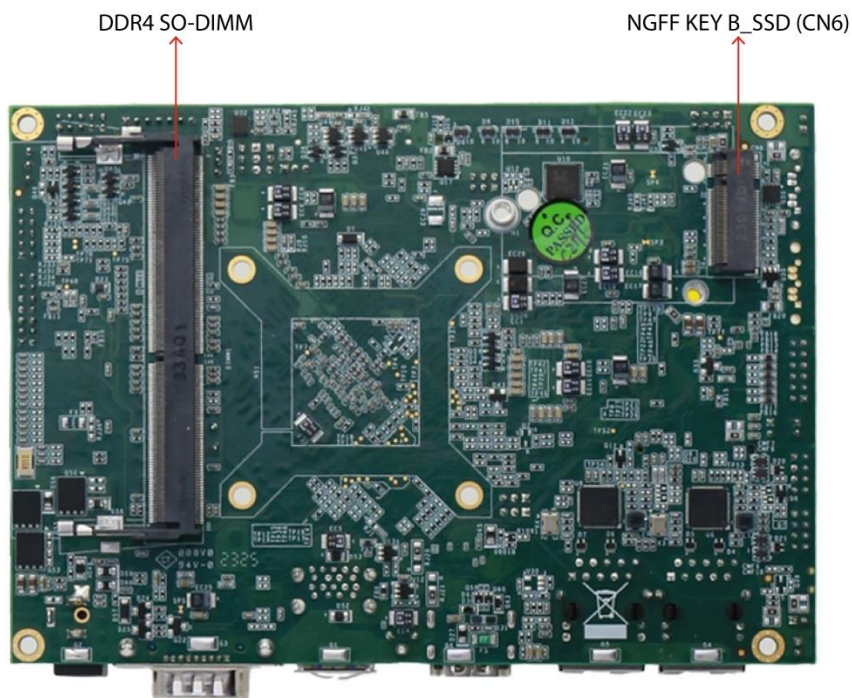

### 2.1.3 IO side

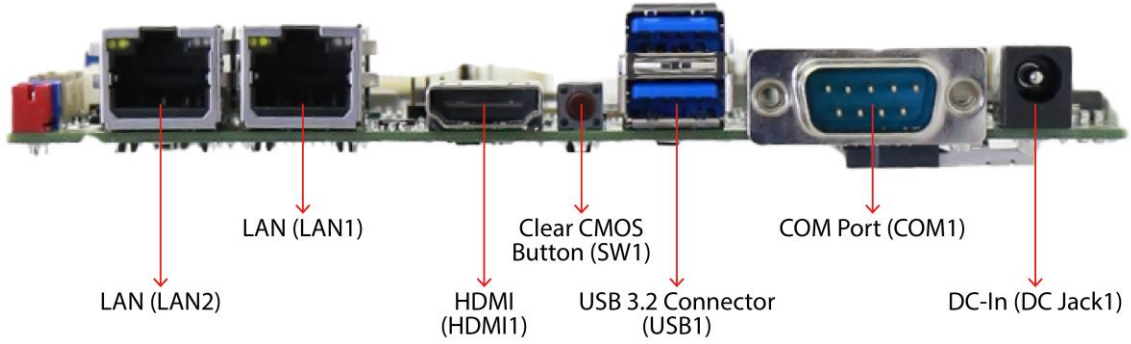

## 2.2 Memory Module (SO-DIMM) Installation

The IE32 3.5" SBC has one SODIMM slot. The socket supports DDR4.

When installing the memory unit, please follow the steps below:

1. Firmly insert the SO-DIMM at an angle of about 30-degree into the slot. Align the SO-DIMM with the slot until it is fully inserted. The notch on the SO-DIMM should match the break on the slot.
2. Press downwards on SO-DIMM until the retaining clips at both ends fully snap closed and the SO-DIMM is properly seated.

Pull the tabs away with your thumbs, bracing your forefingers against the rails. The memory module will be released. Then raise the memory module to a vertical position.

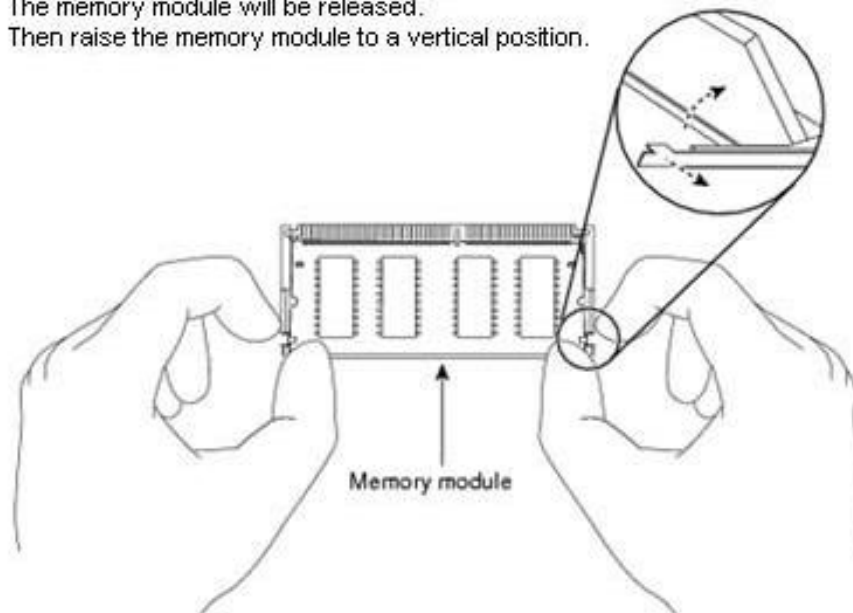

### CAUTION

The SO-DIMM only fits in one correct orientation. It will cause permanent damage to the development board and the SO-DIMM if the SO-DIMM is forced into the slot at the incorrect orientation.

## **2.3 I/O Equipment Installation**

### **2.3.1 Power Input 12V DC in**

The IE32 3.5" SBC allows plugging 12V DC-IN jack on the board without another power module converter under power consumption by Intel® Celeron® Processor N series.

### **2.3.2 Serial COM Port**

One RS-232 connectors build-in the rear I/O can optional supports RS-422/ 485. You can change serial COM port setting through BIOS. Two RS232 (2x5, 10pin) wafers build-in the internal I/O.

\*When an optional touch-screen ordered with PPC, serial COM port can be connected to a serial or an optional touch-screen.

### **2.3.3 HDMI**

The IE32 3.5" SBC has one HDMI port that can be connected to an external LCD monitor. Use HDMI cable to connect to an external LCD monitor, and connect the power cable to the outlet. The HDMI connector is a standard 19-pin HDMI connector.

### **2.3.4 Ethernet Interface**

The IE32 3.5" SBC is equipped with Intel Gigabit-LAN Controller which is fully compliant with the PCIe Ethernet protocol compatible. It is supported by major network operating systems. The Ethernet ports provide two standard RJ-45 jacks.

### **2.3.5 USB Port**

Six USB devices (four with pin headers) may be connected to the system though an adapter cable. Various adapters may come with USB ports. USB usually connect the external system to the system. The USB ports support hot plug-in connection. Whatever, you should install the device driver before you use the device.

### **2.3.6 Audio**

The Audio is provided by a Realtek HD Audio Codec supporting digital audio outputs. The audio interface includes Mic-in / Line-in / Line-out.

## 2.4 Jumper Settings

This section explains how to set jumpers for correct configuration of the motherboard.



### NOTE:

A pair of needle nose pliers may be helpful when working with jumpers. If you have any doubts about the best hardware configuration for your application, contact your local distributor or sales representative before you make any changes. Generally, you simply need a standard cable to make most connections.

The jumper setting diagram is shown below. When the jumper cap is placed on both pins, the jumper is SHORT. The illustration below shows a 3-pin jumper; pins 1 and 2 are short. If you remove the jumper cap, the jumper is OPEN.

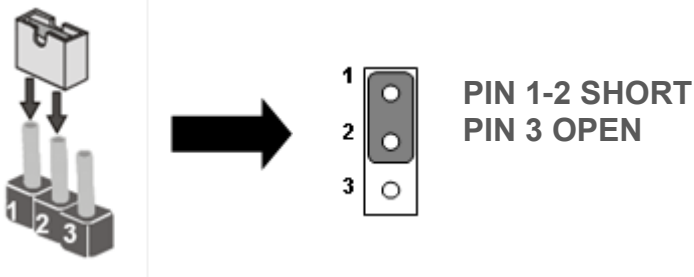

### CAUTION

To avoid damaging the module, always turn off the power supply before setting jumpers or clearing CMOS.



Jumpers		
Label	Function	Note
JP1	Backlight Power Voltage Select	1x3 header, pitch 2.0mm
JP2	PWM/DC Mode Select	1x3 header, pitch 2.0mm
JP3	Panel Power Voltage Select	2x3 header, pitch 2.54mm
JP4	Brightness PWM Control Select	1x3 header, pitch 2.0mm

### 2.4.1 JP1: Backlight Power Voltage Select

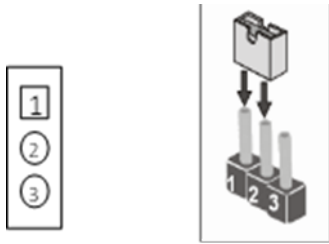

Pin No	Signal Name
1-2 (Default)	+5V
2-3	+12V

### 2.4.2 JP2: PWM/DC Mode Select

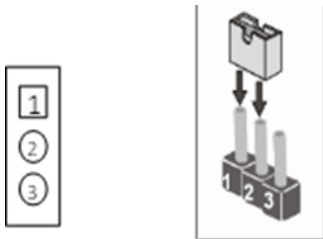

Pin No	Signal Name
1-2 (Default)	PWM Mode
2-3	DC Mode

### 2.4.3 JP3: Panel Power Voltage Select

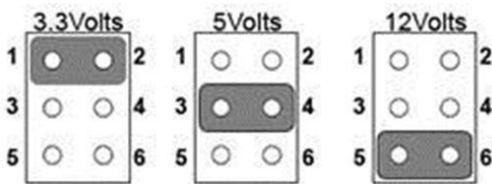

Pin No	Signal Name
1-2 (Default)	+3.3V
3-4	+5V
5-6	+12V

### 2.4.4 JP4: Brightness PWM Control Select

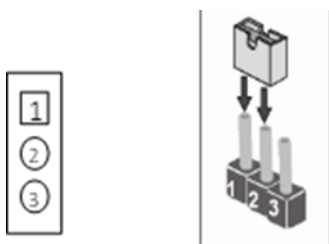

Pin No	Signal Name
1-2 (Default)	Chipset
2-3	VR Control

## 2.5 Mainboard Connectors

### 2.5.1 External I/O Side Connectors

Label	Function	Note
<b>Connector</b>		
DCJACK1	DC Jack	2.5 $\phi$ DC Jack
COM1	Serial port (RS232/422/485)	D-Sub9 (Male)
USB1	2 x USB 3.2 Gen2 x1 (10Gbps)	USB Type A
HDMI1	HDMI 2.0 Signal	HDMI Type A
LAN1, LAN2	2.5Gigabit Ethernet	RJ45+LED
SW1	Clear CMOS, Reset	Button

#### 2.5.1.1 DCJACK1: Power 2.5 $\phi$ DC Jack Connector

The DC power input for the IT32 Motherboard allows a voltage input of 12V DC.

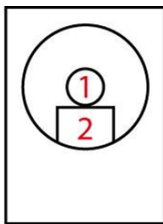

Pin No	Signal Name	Pin No	Signal Name
1	12VDC	2	GND

#### 2.5.1.2 COM1: D-Sub9 (Male)

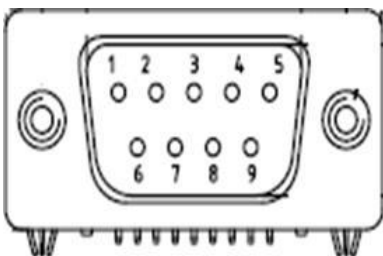

Pin No	RS232(Default)	RS422	RS485
1	DCD	TxD-	D-
2	RXD	TxD+	D+
3	TXD	RxD+	NC
4	DTR	RxD-	NC
5	GND	GND	GND
6	DSR	NC	NC
7	TRTD	NC	NC
8	CTS	NC	NC
9	RI	NC	NC

### 2.5.1.3 USB1, USB2: USB 3.2

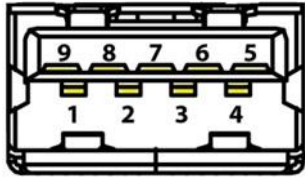

Pin No	Signal Name	Pin No	Signal Name
1	+5V	2	USB_D-
3	USB_D+	4	GND
5	STDA_SSRX-	6	STDA_SSRX+
7	GND_DRAIN	8	STDA_SSTX-
9	STDA_SSTX+		

### 2.5.1.4 HDMI1: HDMI 2.0 Type A

Use HDMI connector to connect the IE32 to an external monitor.



Pin No	Signal Name	Pin No	Signal Name
1	HDMI_DET	2	NV
3	HDMI_D2P	4	GND
5	HDMI_D2M	6	HDMI_D1P
7	GND	8	HDMI_D1M
9	HDMI_D0P	10	GND
11	HDMI_D0M	12	HDMI_CLKP
13	GND	14	HDMI_CLKM
15	HDMI_CEC_OUT	16	GND
17	DDC_CLOCK	18	DDC_DATA
19	+5V	20	GND

### 2.5.1.5 LAN1, LAN2: 2.5Gigabit Ethernet

IT32 has two Ethernet connectors located on the front. Ethernet ports provide a standard RJ45 jack connector with LED indicators on the front side to show its Active/ Link status and Speed status.

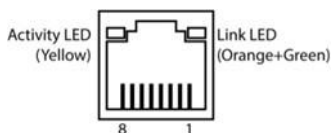

Pin No	Signal Name	Pin No	Signal Name
1	TX1+	2	TX1-
3	TX2+	4	TX2-
5	TX3+	6	TX3-
7	TX4+	8	TX4-

## 2.5.2 Internal I/O Side Connectors

Label	Function	Note
DCJACK2	DC in	1x2P wafer
CON1	Backlight Power/Control	1 x 7 wafer, pitch 2.0 mm
BT1	RTC Battery	2P wafer, pitch 1.25 mm
COM2.3.	COM Port	2 x 5 header, pitch 2.0mm
DIDO1	Digital I/O Header	2 x 7 wafer, pitch 2.0mm
CN3	eDP Connector	2 x 15 wafer, pitch 1.25mm
CPU_FAN1	CPU FAN	3P 2.54mm DIP180°
LVDS1	LVDS Connector	2 x 20 wafer, pitch 1.25mm
CN6	M.2 Key B SSD	NGFF KEY B Slot
CN7	M.2 Key E WIFI/BT	NGFF KEY E Slot
CN1	Front Panel	2 x 5 wafer, pitch 2.0mm
SATA1	SATA Connector	WATM-07ABN4A2B8UW
SATA_PWR1	SATA Power	2 x 4 wafer, pitch 2.0mm
AUDIO1	Audio	2 x 6 wafer, pitch 2.0mm
CN5	Left Speaker	1 x 2 wafer, pitch 2.0 mm
CN4	Right Speaker	1 x 2 wafer, pitch 2.0 mm
USB2/ USB3	USB 2.0 Wafer	2 x 4 wafer, pitch 2.0 mm
CN2	Backlight Control VR	1 x 3 wafer, pitch 2.0mm
12V1	Power Output Wafer 12V	1x2 wafer, pitch 2.0 mm. Yellow color
5V1	Power Output Wafer 5V	1x2 wafer, pitch 2.0 mm. Red color
3.3V1	Power Output Wafer 3.3V	1x2 wafer, pitch 2.0 mm. Blue color

### 2.5.1.2 DCJACK2 : 2P wafer



Pin No	Signal Name	Pin No	Signal Name
1	+12V	2	GND

### 2.5.2.1 CON1: Backlight Power/Control

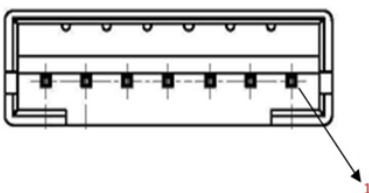

Pin No	Signal Name	Pin No	Signal Name
1	BKL_PWR	2	BKL_PWR
3	BKL_PWR	4	GND
5	BRIGHT	6	GND
7	BLON_5V		

#### BKLIGHT1

**Note:** Please refer to JP1 settings to select Power Rating.

### 2.5.2.2 BT1: RTC Battery

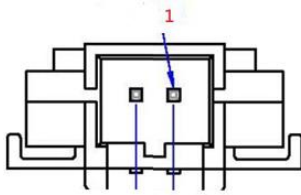

**BT1**

Pin No	Signal Name	Pin No	Signal Name
1	GND	2	+3.3V

### 2.5.2.3 COM2/COM3: Internal RS232 COM

The serial port which is Winbond I/O support is RS232 only.

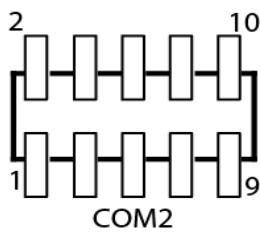

**COM2**

Pin No	Signal Name	Pin No	Signal Name
1	FK_NDCD2	2	FK_NDSR2
3	FK_NSIN2	4	FK_NRTS2
5	FK_NSOUT2	6	FK_NCTS2
7	FK_NDTR2	8	FK_NRI2
9	GND	10	GND

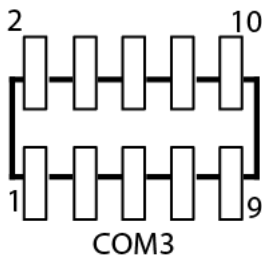

**COM3**

Pin No	Signal Name	Pin No	Signal Name
1	FK_NDCD3	2	FK_NDSR3
3	FK_NSIN3	4	FK_NRTS3
5	FK_NSOUT3	6	FK_NCTS3
7	FK_NDTR3	8	FK_NRI3
9	GND	10	GND

### 2.5.2.4 DIDO1: Digital I/O Header

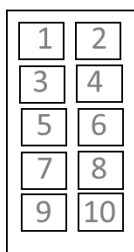

**DIDO1**

Pin No	Signal Name	Pin No	Signal Name
1	GND	2	DIO_5V
3	DOUT3	4	DOUT1
5	DOUT2	6	DOUT0
7	DINT3	8	DINT1
9	DINT2	10	DINT0

### 2.5.2.5 CN3: eDP Connector

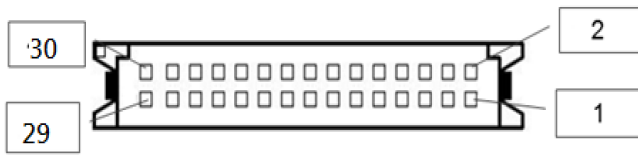

Pin No	Signal Name	Pin No	Signal Name
1	EMB_AUXN	2	SMB_DATA_MAIN
3	EMB_AUXP	4	SMB_DATA_CLK
5	GND	6	GND
7	DP_TXN3_C	8	+VCC_EDP_BKLT
9	DP_TXP3_C	10	+VCC_EDP_BKLT
11	GND	12	+VCC_EDP_BKLT
13	DP_TXN2_C	14	GND
15	DP_TXP2_C	16	GND
17	GND	18	GND
19	DP_TXN1_C	20	GND
21	DP_TXP1_C	22	LCDVDD
23	GND-	24	LCDVDD
25	DP_TXN0_C	26	LCDVDD
27	DP_TXP0_C	28	LCDVDD
29	GND	30	+VCC_EDP_BKLT

### 2.5.2.6 CPU\_FAN1: CPU FAN

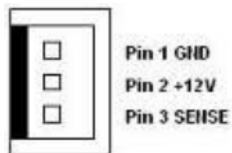

**FAN1**

Pin No	Signal Name	Pin No	Signal Name
1	GND	2	+12V
3	SENSE		

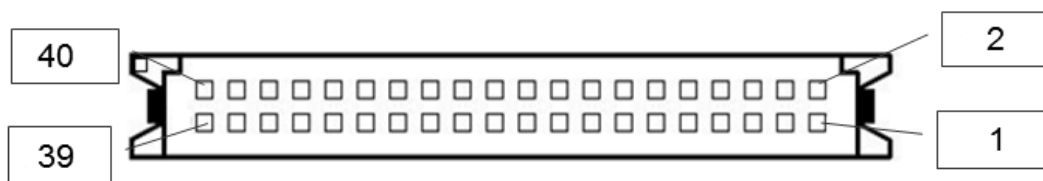
**2.5.2.7 LVDS1: LVDS Connector****CN12**

Pin No	Signal Name	Pin No	Signal Name
1	LCDVDD	2	LVDS0_TX0_N
3	LCDVDD	4	LVDS0_TX0_P
5	LCDVDD	6	LVDS0_TX1_N
7	GND	8	LVDS0_TX1_P
9	GND	10	LVDS0_TX2_N
11	GND	12	LVDS0_TX2_P
13	GND	14	LVDS0_CLK_N
15	GND	16	LVDS0_CLK_P
17	GND	18	LVDS0_TX3_N
19	GND	20	LVDS0_TX3_P
21	GND	22	LVDS1_TX0_N
23	GND	24	LVDS1_TX0_P
25	GND	26	LVDS1_TX1_N
27	GND	28	LVDS1_TX1_P
29	GND	30	LVDS1_TX2_N
31	GND	32	LVDS1_TX2_P
33	GND	34	LVDS1_CLK_N
35	GND	36	LVDS1_CLK_P
37	GND	38	LVDS1_TX3_N
39	GND	40	LVDS1_TX3_P

**2.5.2.8 CN6:NGFF\_KEY B SSD**

The IE32 3.5" SBC has NGFF M.2 connector for SATAIII.

**2.5.2.9 CN7:NGFF\_KEY E WIFI/BT**

The IE32 3.5" SBC has NGFF M.2 Key E connector for WIFI/BT.

### 2.5.2.10 CN1: Front Panel

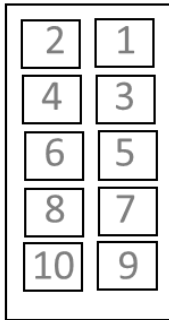

PANEL 1

Pin No	Signal Name	Pin No	Signal Name
1	PW_LED+	2	HD_LED+
3	GND	4	HD_LED-
5	PW_BT	6	GND
7	BRI+	8	RST-BT
9	BRI-	10	5VSB

### 2.5.2.11 SATA1: SATA Connector

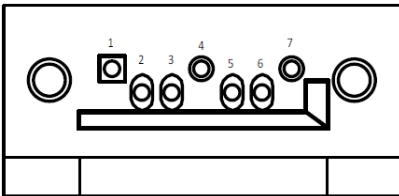

Pin No	Signal Name	Pin No	Signal Name
1	GND	2	SATA_TXP
3	SATA_TXN	4	GND
5	SATA_RXN	6	SATA_RXP
7	GND		

### 2.5.2.12 SATA\_PWR1: SATA Power Connector

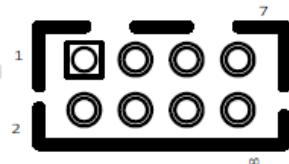

Pin No	Signal Name	Pin No	Signal Name
1	+12V	2	+12V
3	GND	4	GND
5	GND	6	GND
7	+5V	8	+5V

### 2.5.2.13 AUDIO1: Audio

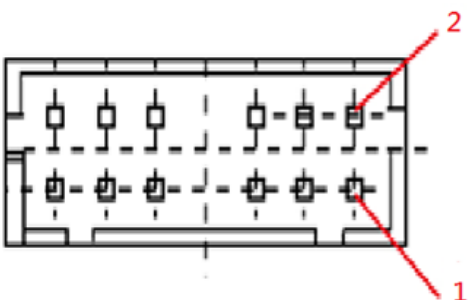

Pin No	Signal Name	Pin No	Signal Name
1	LINE_OUT_R	2	LINE_OUT_L
3	+5V	4	GND
5	LINE_IN_R	6	LINE_IN_L
7	MIC_R	8	MIC_L
9	GND	10	LINE_OUT_JACK
11	MIC_JACK DET	12	LINE_IN_JACK

**2.5.2.14 CN5,CN4 :Left: SPK\_L & SPK\_R**



**LEFT**

Pin1 LOUT+  
Pin2 LOUT-



**RIGHT**

Pin1 ROUT+  
Pin2 ROUT

Pin No	Signal Name	Pin No	Signal Name
1	LOUT+	2	LOUT-

**2.5.2.15 USB2/USB3: USB 2.0 Wafer**

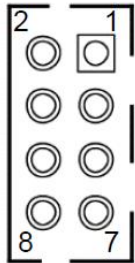

Pin No	Signal Name	Pin No	Signal Name
1	USB1_PWR	2	USB2_PWR
3	USB1_D-	4	USB2_D-
5	USB1_D+	6	USB2_D+
7	GND	8	GND

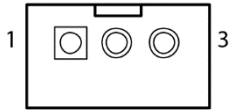
**2.5.2.16 CN2: VR Knob**

Pin No	Signal Name	Pin No	Signal Name
1	+V5S	2	VRD_ADC
3	GND		

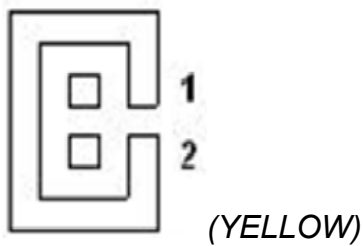
**2.5.2.17 12V1: 12V Power Output**

Pin No	Signal Name	Pin No	Signal Name
1	+12V	2	GND

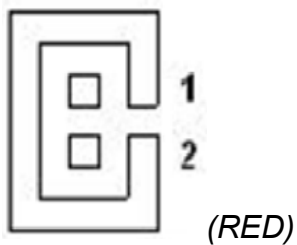
**2.5.2.18 5V1: 5V Power Output**

Pin No	Signal Name	Pin No	Signal Name
1	+5V	2	GND

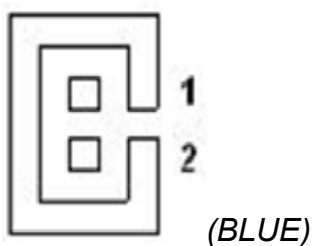
**2.5.2.19 3V1: 3.3V Power Output**

Pin No	Signal Name	Pin No	Signal Name
1	+3.3V	2	GND

## Chapter 3: Insyde H20 BIOS Setup

This chapter describes the different settings available in the INSYDE BIOS that comes with the board. This chapter offers information on the Award BIOS installation utility.

3.1 Main Menu

3.2 Advanced

3.3 Using Recovery Wizard to Restore Computer

---

## 3.1 Main Menu

When you enter BIOS setup, the first menu that appears on the screen is the main menu. The Main menu displays the basic information about your system including BIOS version, processor RC version, system language, time, and date. It contains the system information including BIOS version, processor RC version, system language, time, and date.

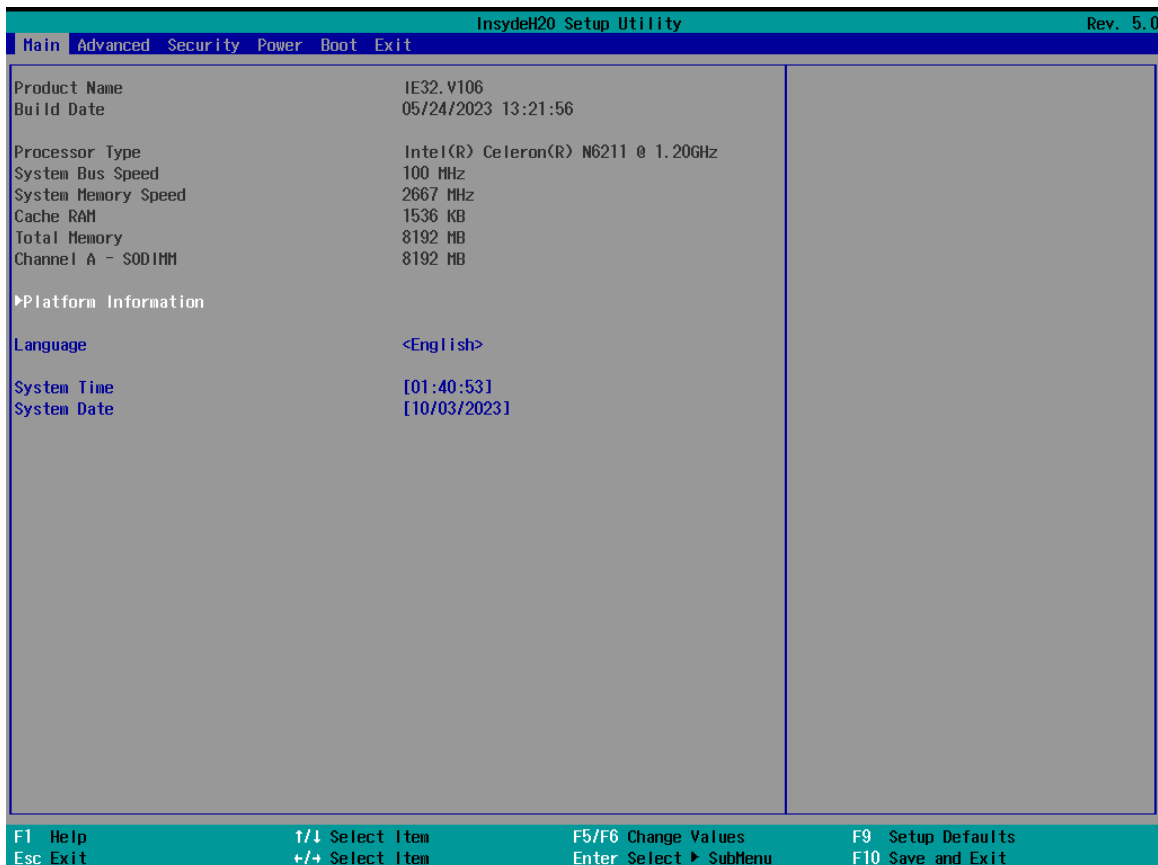

BIOS Setting	Description	Setting Option	Effect
<b>Language</b>	Displays the system language. [English] is set up by default.	Adjustment of the language	Set the language in other language. The language in this device is English.
<b>System Time</b>	This is current time setting. The time is maintained by the battery when the device is turned off.	Date and time changes.	Set the time in the format: [hh/mm/ss]
<b>System Date</b>	This is current date setting.	Date and time changes.	Set the date in the format [mm/dd/yyyy];

## 3.2 Advanced

Select the Advanced Tab from the setup menu to enter the advanced BIOS setup screen. You can select any of the items on the left frame of the screen to go to the sub menu for the item, such as CPU Configuration. You can use the <Arrow> keys enter all advanced BIOS setup options. The advanced BIOS setup menu is shown below. The submenus described on the following pages.



### CAUTION

Handle advanced BIOS settings page with caution. Any changes can affect the operation of your computer.

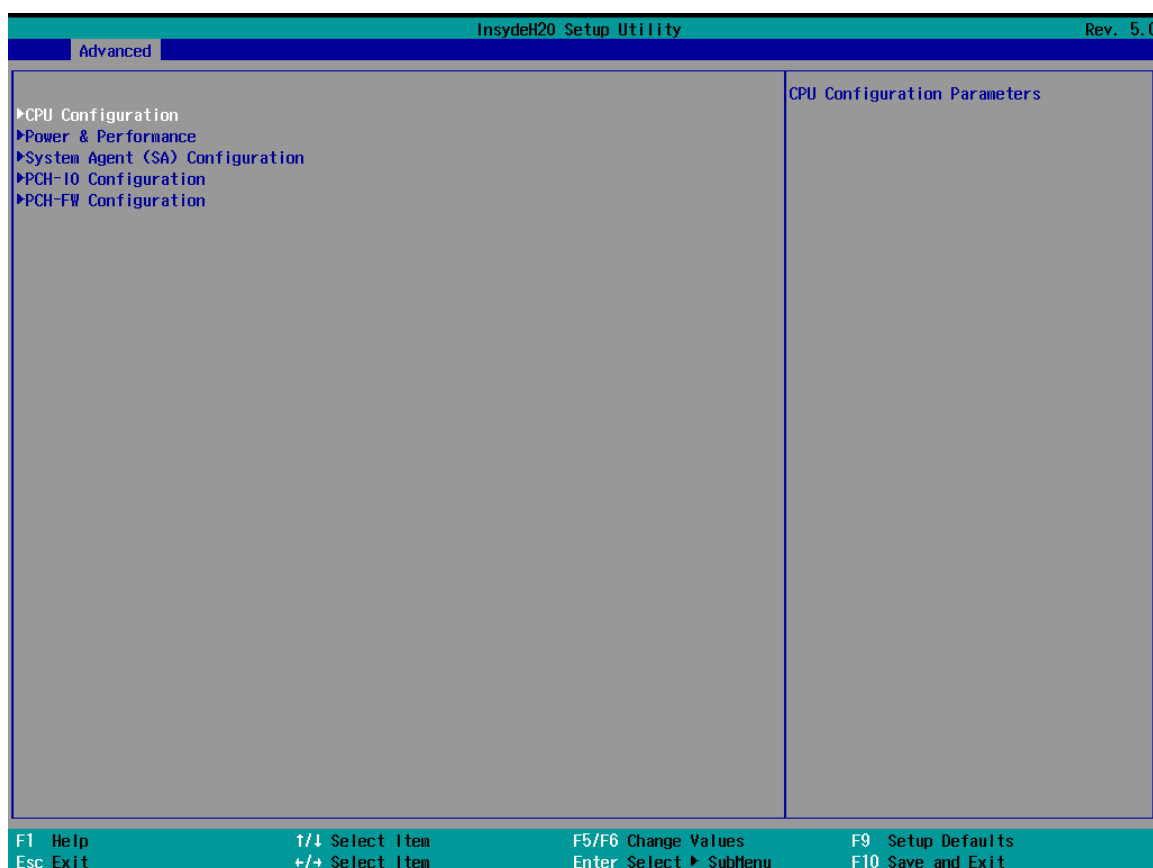

BIOS Setting	Description	Setting Option	Effect
CPU Configuration	Configures Trusted Computing parameters	Enter	Opens submenu
Power & Performance	Configures Power & Performance parameters	Enter	Opens submenu
System Agent Configuration	Configures System Agent Configuration parameters	Enter	Opens submenu
PCH-IO Configuration	Configures PCH-IO parameters	Enter	Opens submenu
PCH-FM Configuration	Configures PCH-FM parameters	Enter	Opens submenu
SIO F81968	Configures SIO F81968 parameters	Enter	Opens submenu

### 3.2.1 CPU Configuration

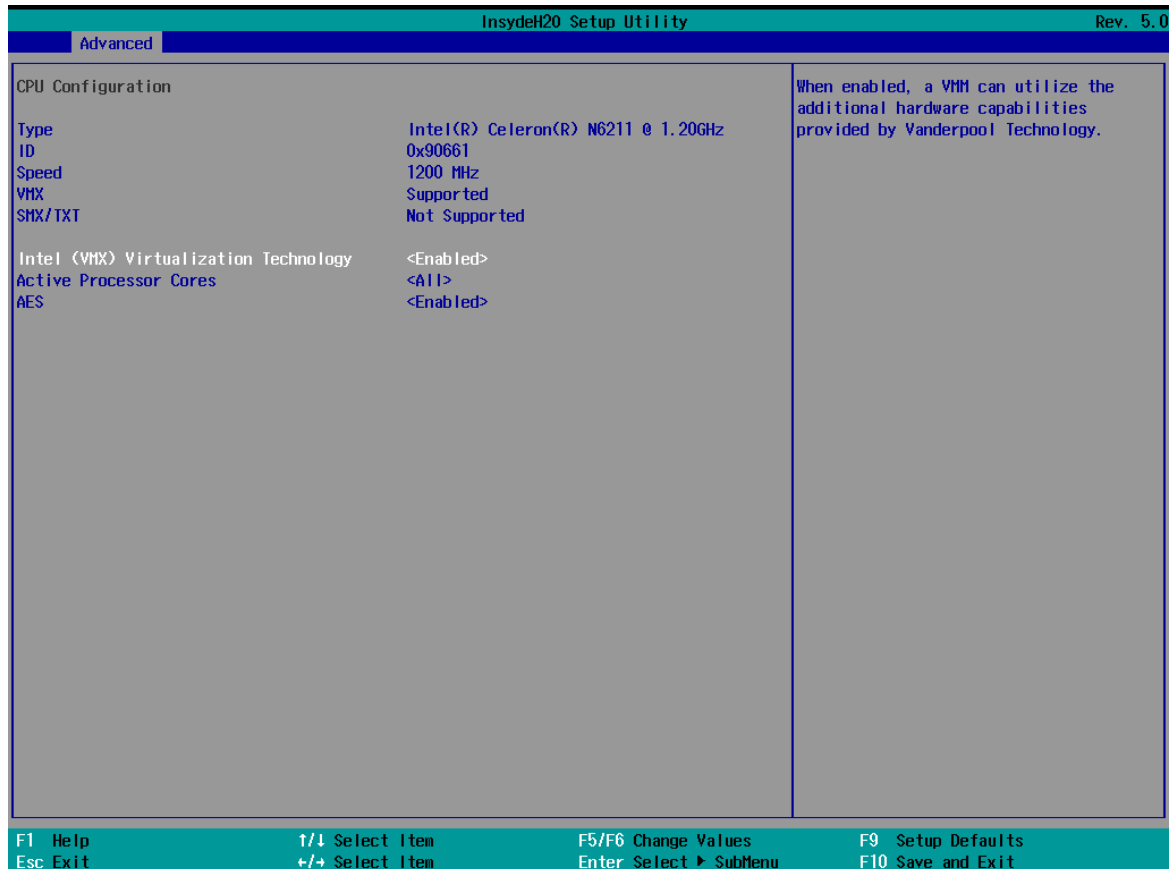

BIOS Setting	Description	Setting Option	Effect
Intel (VMX) Virtualization Technology	Enable or disable Intel Virtualization Technology.	Enable/Disable	When enabled, a VMM can utilize the additional hardware capabilities provided by Vanderpool Technology.
Active Processor Cores	Number of core to enable in each processor package	All / 1 / 2/ 3	Select number of core to enable in each processor package
Hyper Threading	Intel Hyper-Threading Technology allows a single processor to execute two or more separate threads concurrently.	Enable / Disable	Enable or disable Hyper Threading
AES	Enable or disable AES (Advanced Encryption Standard)	Enable/Disable	Enable or disable AES

### 3.2.2 F81968 Configuration

If you want to adjust the UART port type, follow below step. First, enter the UART Port1 Configuration and in Peripheral Type, you can choose between RS232/RS422/RS485.

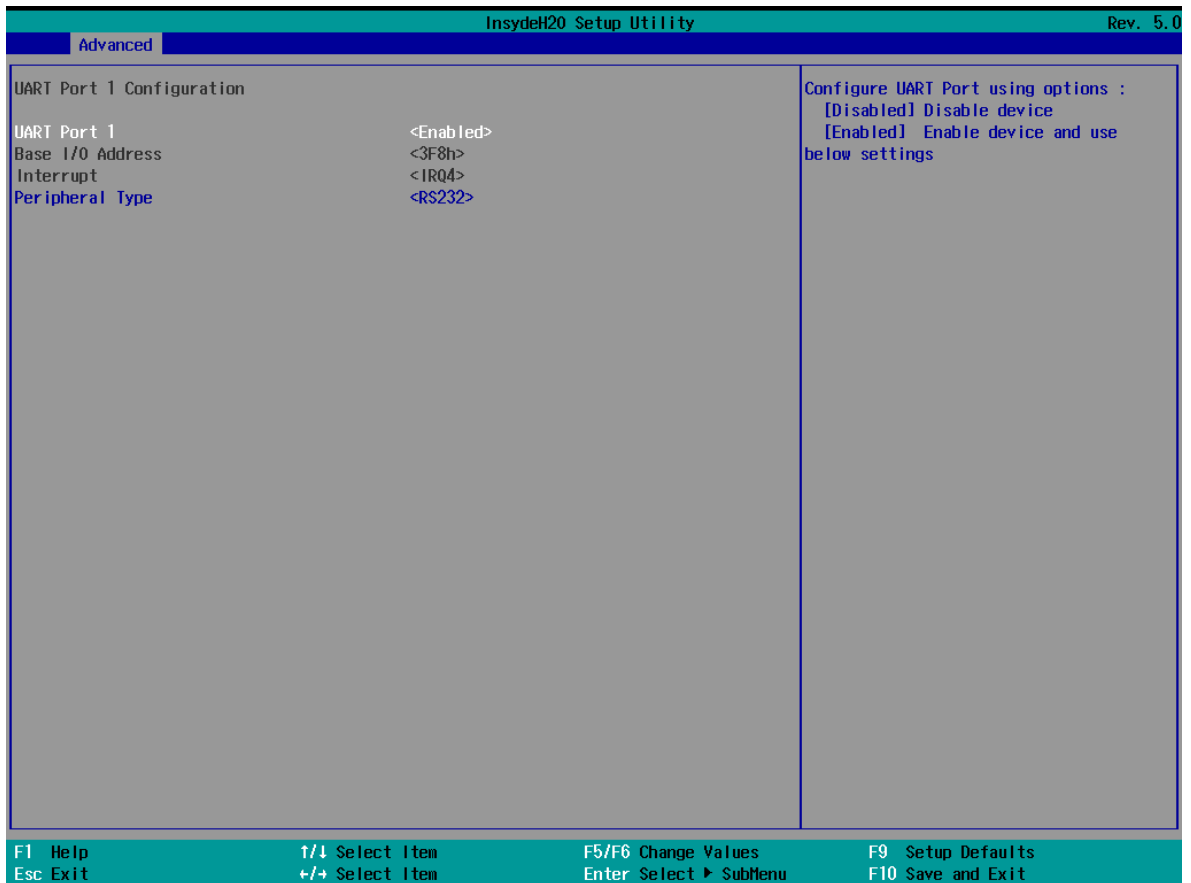
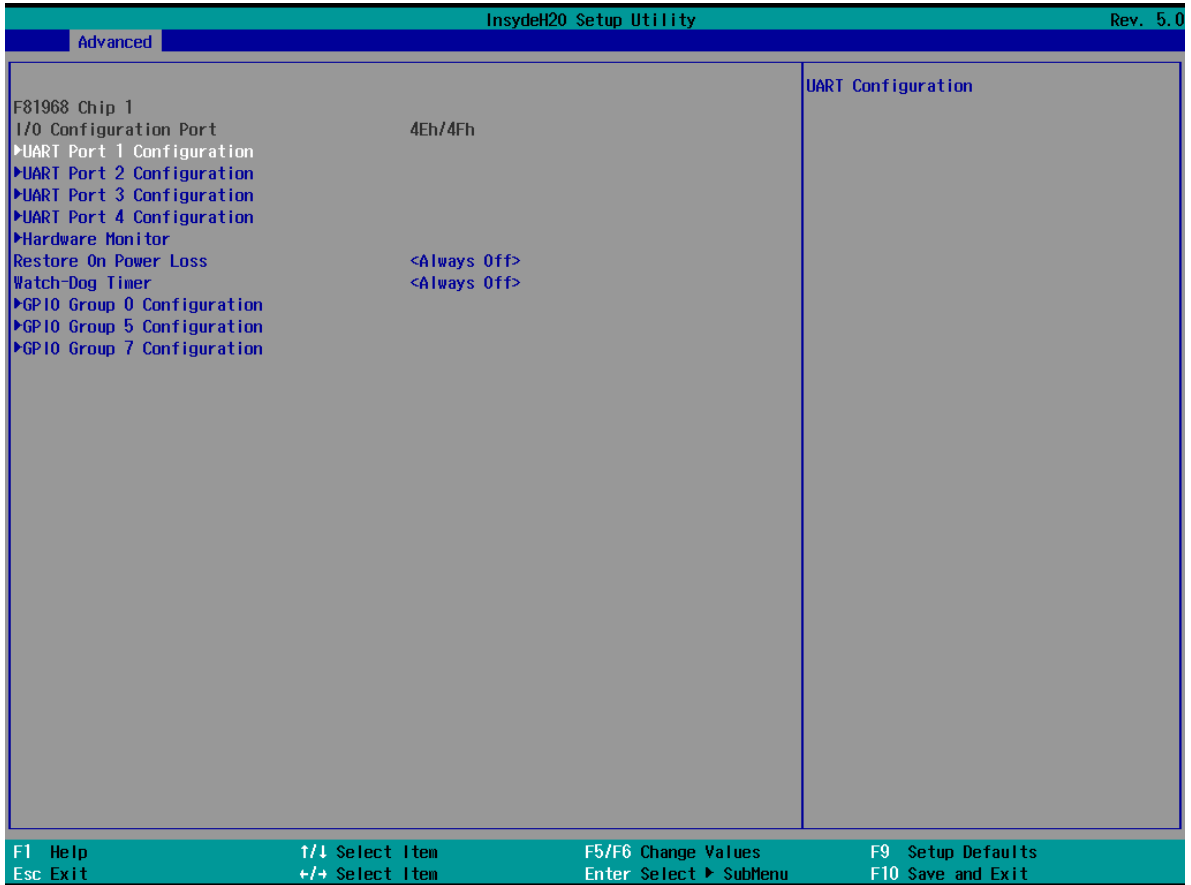

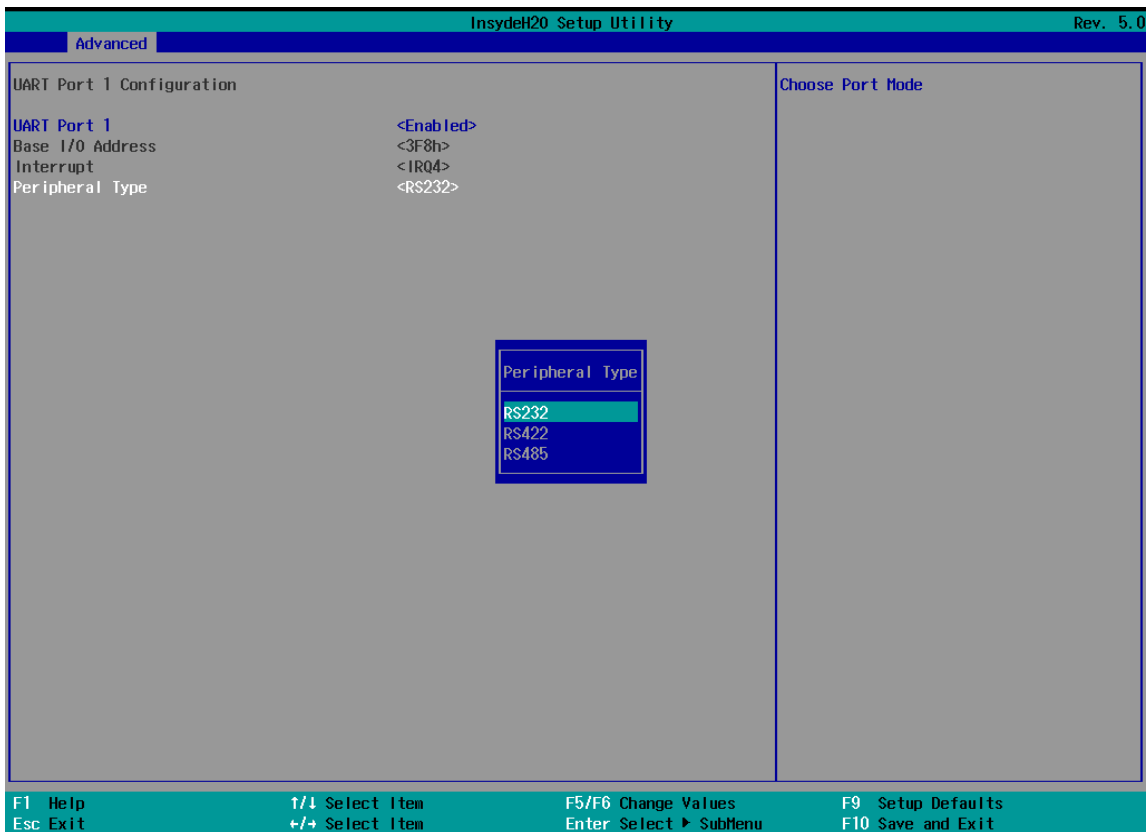

### 3.2.2.1 Restore On Power Loss

In Restore On Power Loss, you can setup whether to restore the product automatically when the Power loss.

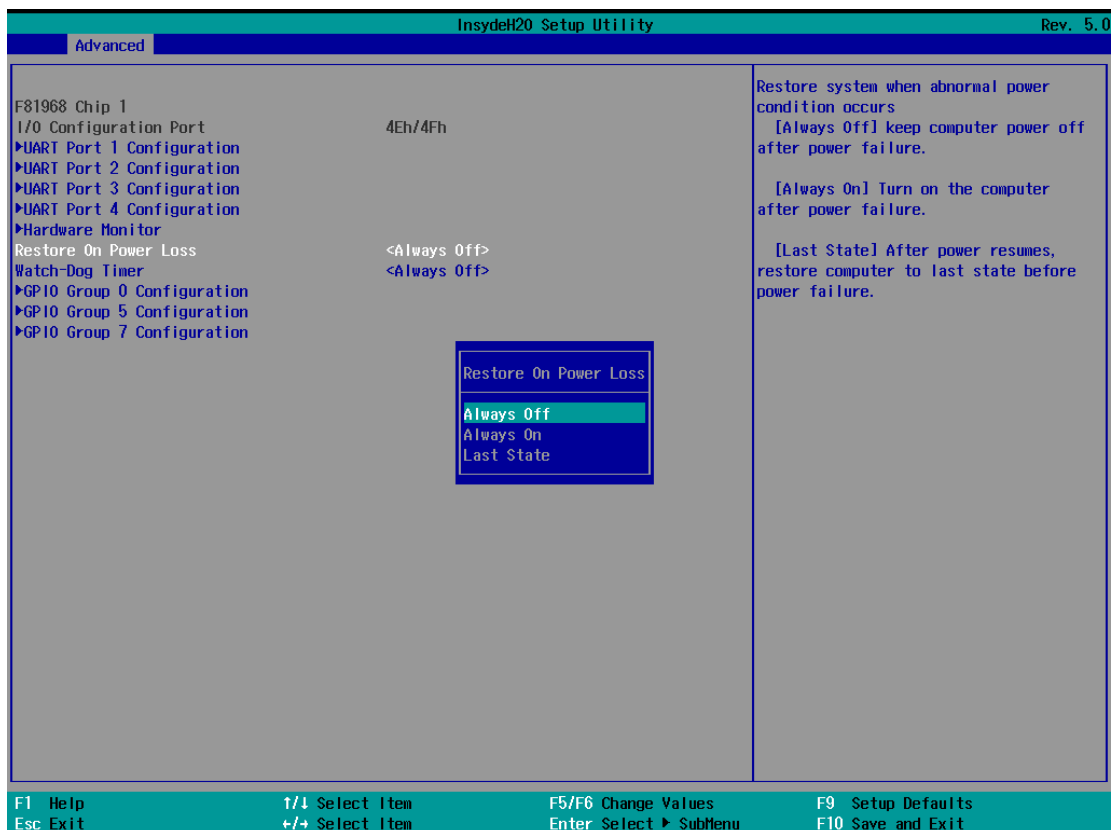

### 3.2.3 Hardware Monitor

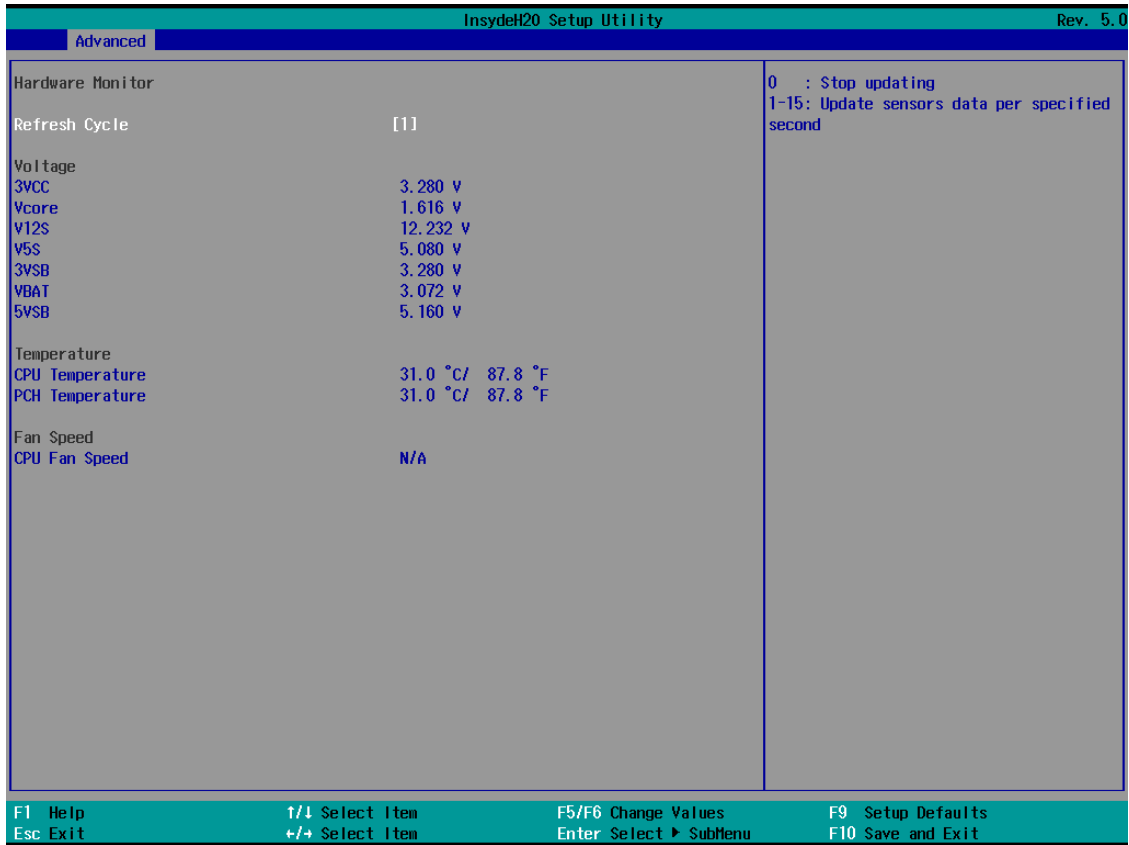

### 3.2.4 PCH-IO Configuration

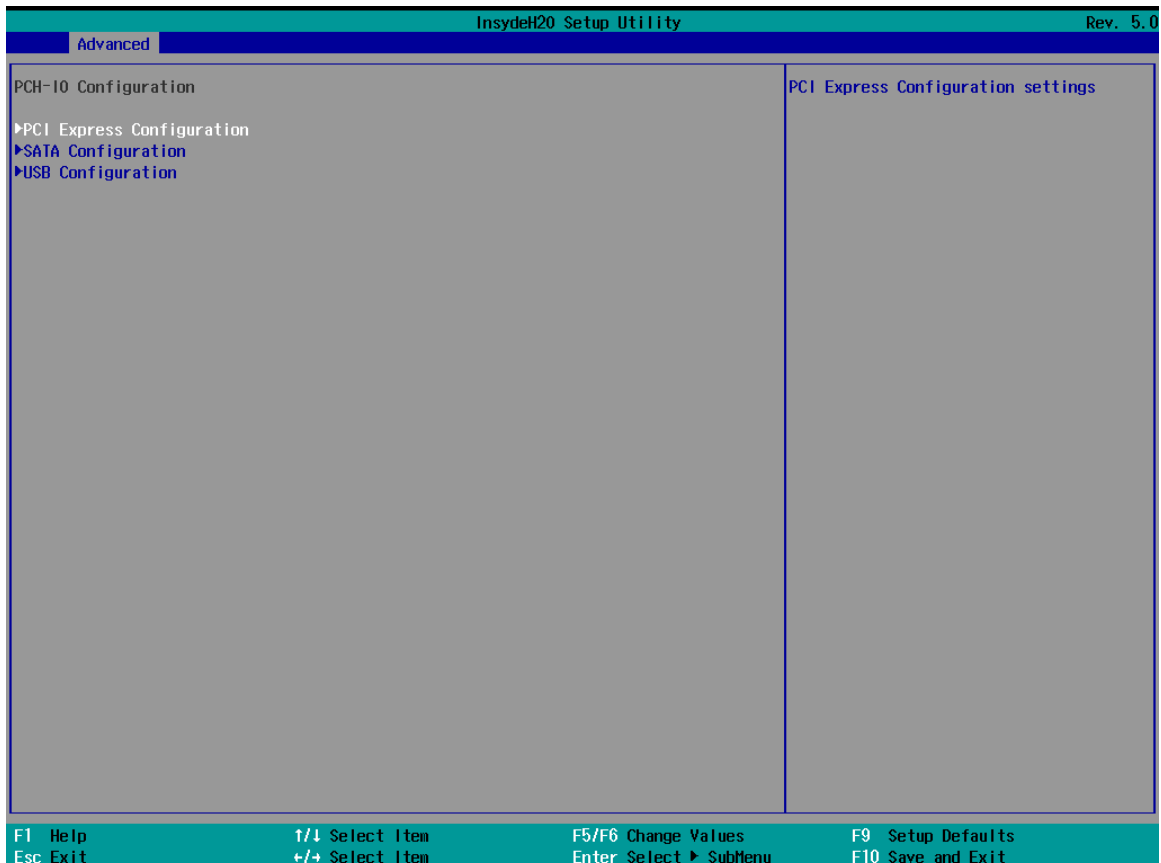

BIOS Setting	Description	Setting Option	Effect
<b>PCI Express Configuration</b>	PCI Express clock gating enable/disable for each root port.	Enter	Opens sub-menu
<b>SATA And RST Configuratuion</b>	Enable/ Disable SATA device	Enter	Opens sub-menu
<b>USB Configuration</b>	Selectively enable/ disable the corresponding USB port from reporting a Device Connection to the controller.	Enter	Opens sub-menu

### 3.2.5 PCI Express Configuration

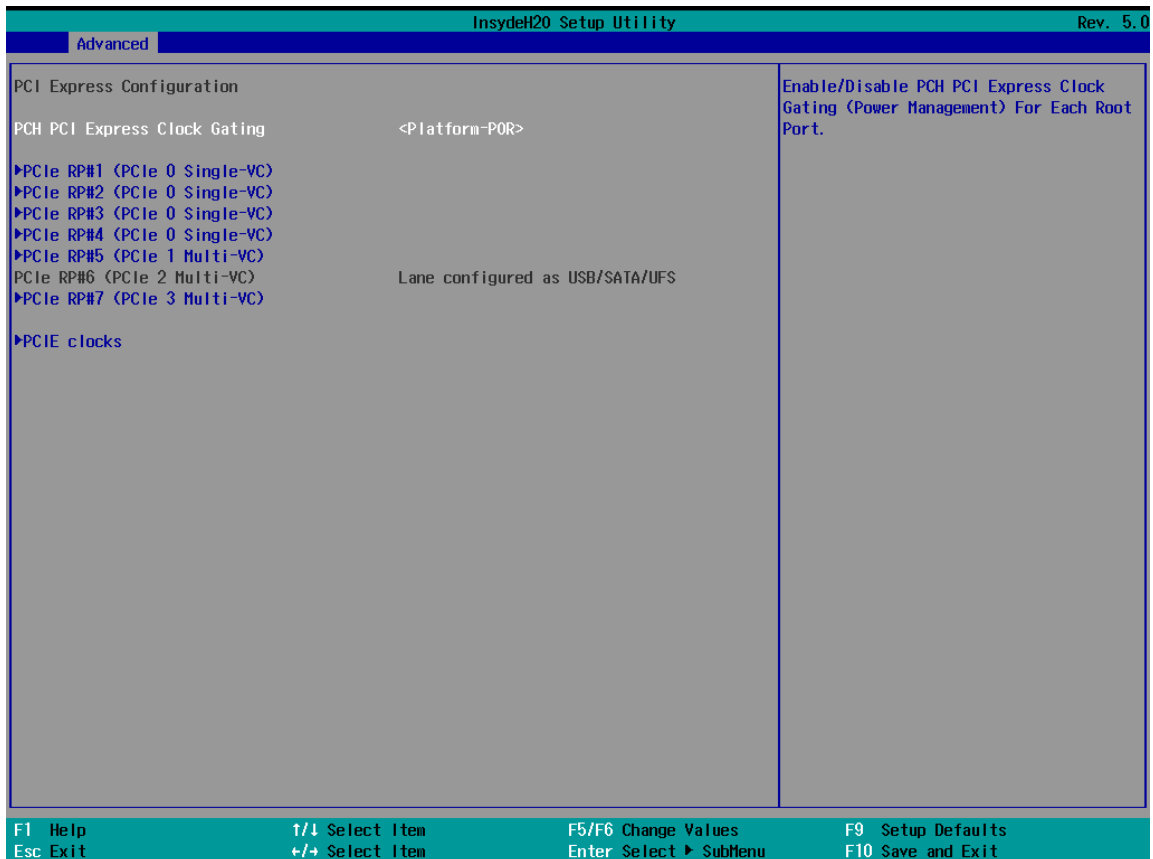

### 3.2.6 SATA and RST Configuration

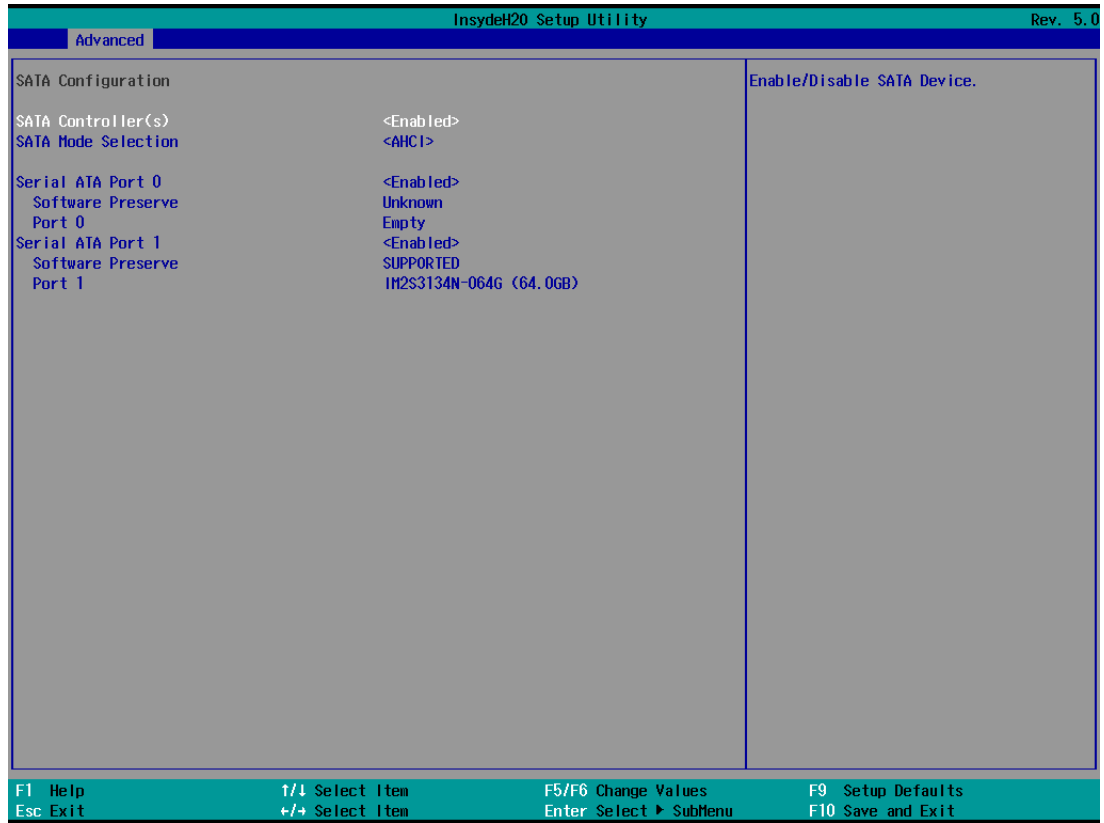

### 3.2.7 USB Configuration

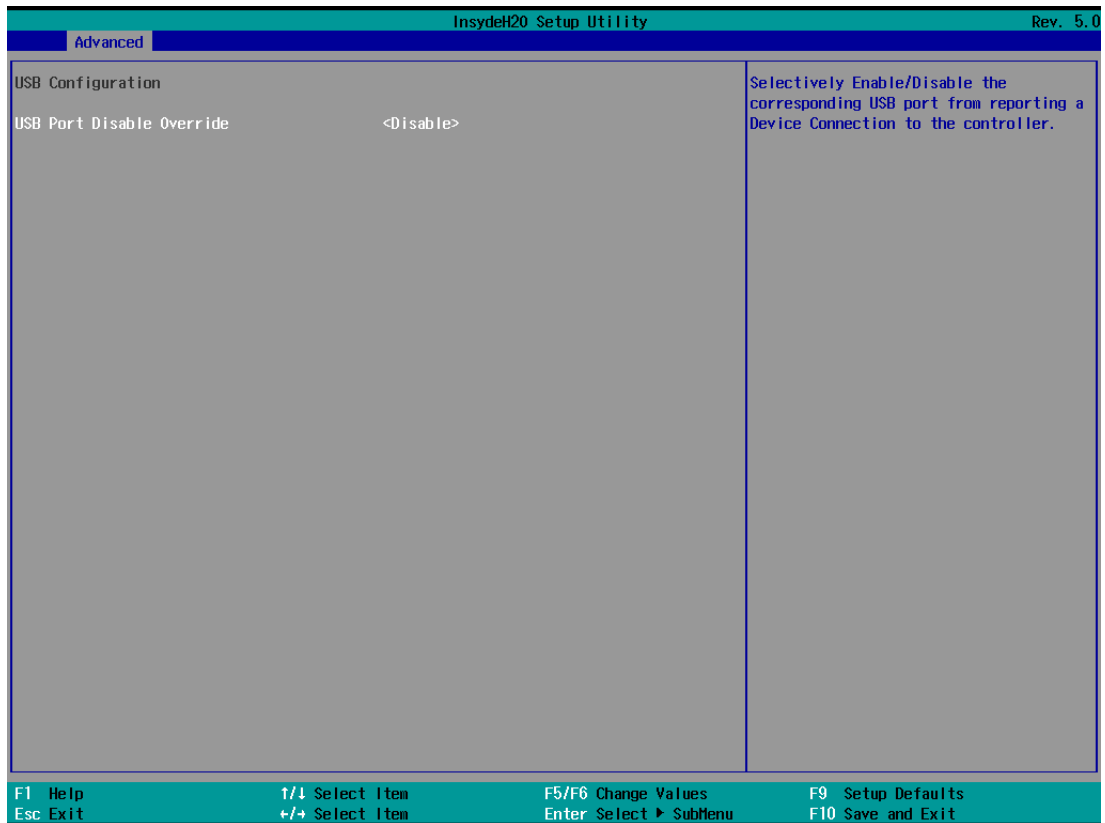

### 3.2.8 Power & Performance

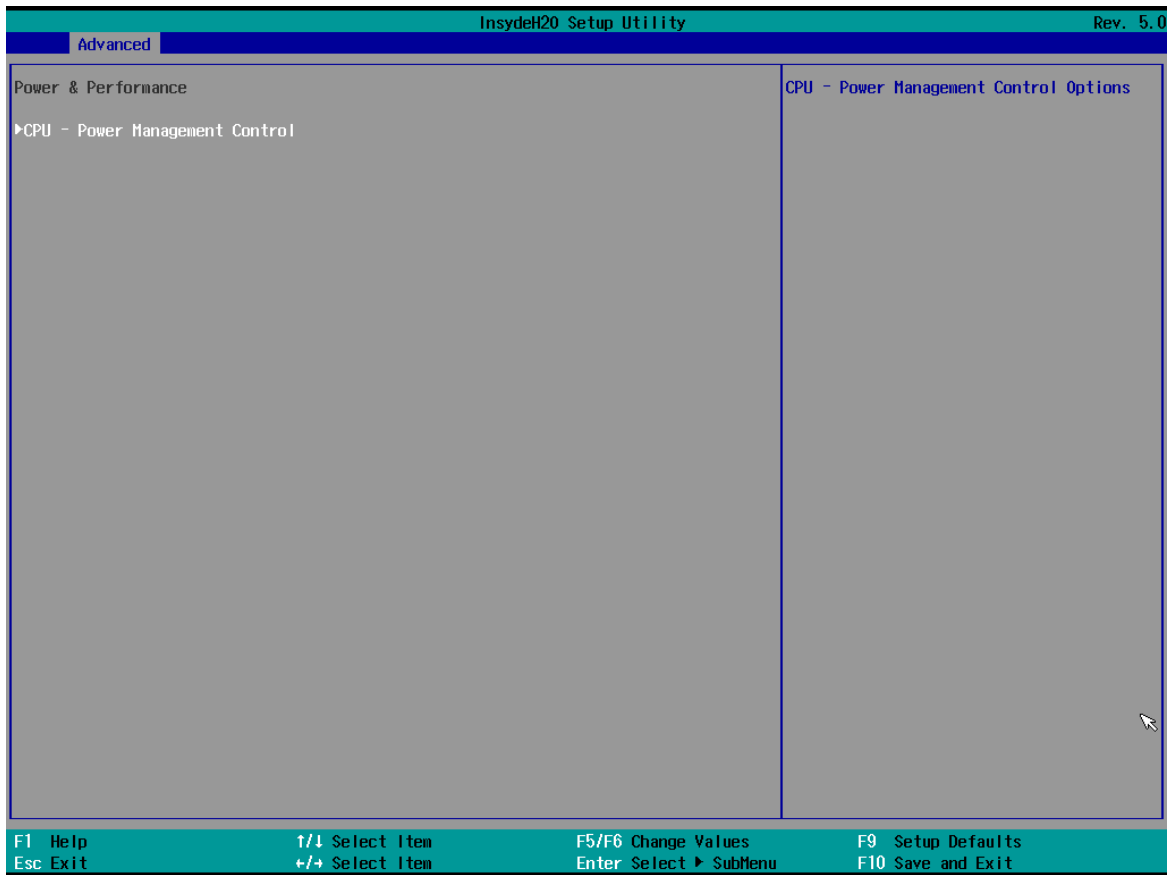

BIOS Setting	Description	Setting Option	Effect
<b>CPU – Power Management Control</b>	Configure CPU – Power Management parameters	Enter	Opens sub-menu

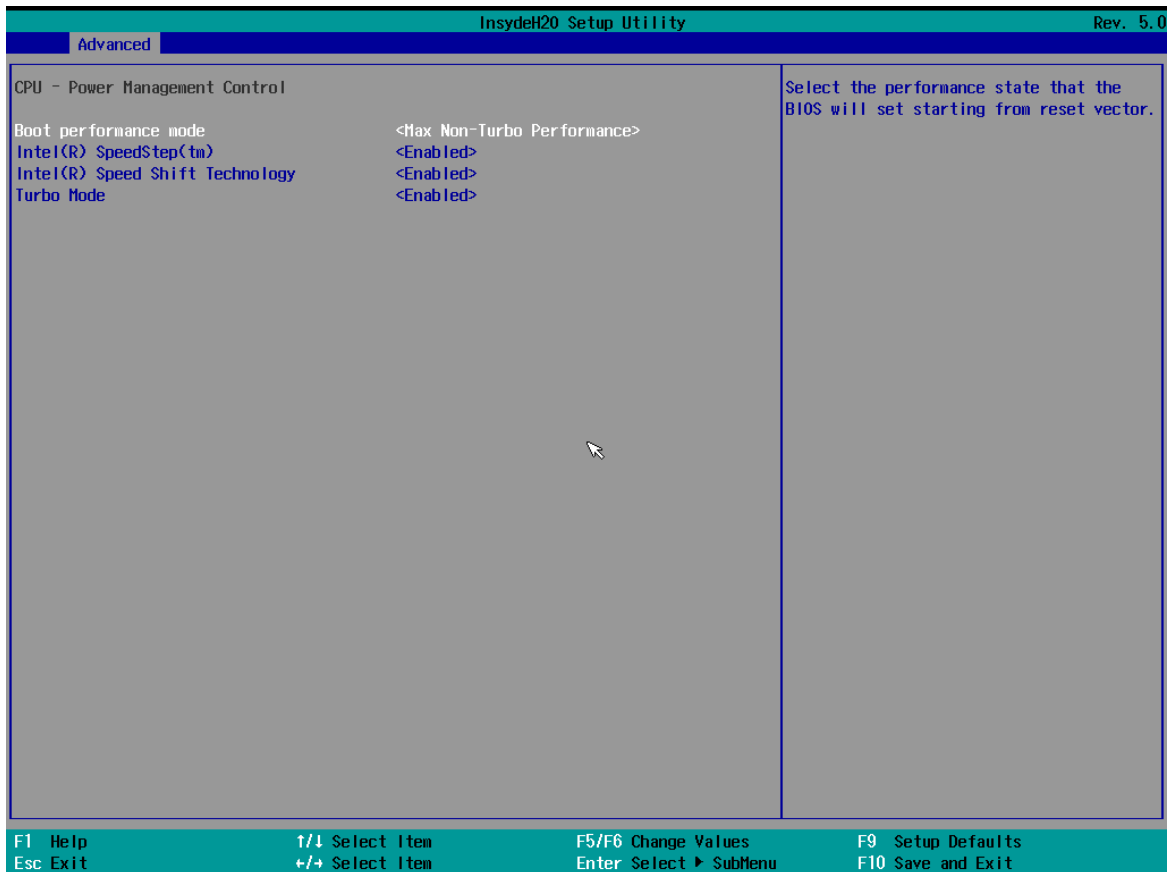

BIOS Setting	Description	Setting Option	Effect
<b>Boot Performance Mode</b>	Configure Boot Performance Mode parameters	-Max non-turbo performance -Max battery -Turbo Performance	Select the performance state that the BIOS will set starting from reset vector
<b>Intel SpeedStep (ta)</b>	Configure Intel SpeedStep (ta) parameters	Enabled/ Disabled	Allows more than two frequency ranges to be supported
<b>Intel Speed Shift Technology</b>	Configure Intel Speed Shift Technology parameters	Enabled/ Disabled	Enable/ Disable Intel Speed Shift Technology support. Enabling will expose the CPP v2 interface to allow for hardware controlled P-states

BIOS Setting	Description	Setting Option	Effect
<b>-Turbo Mode</b>	Enable or disable Turbo Mode	Enabled/ Disabled	Enable/ Disable processor Turbo Mode (requires EMTTM enabled too). Auto means enabled, unless max turbo ratio is bigger than 16 – SKL AO W/A
<b>C states</b>	Enable or disable C states	Enabled/ Disabled	Enable/ Disable CPU Power Management. Allows COU to go to C states when it is not 100% utilized
<b>Custom P-state Table</b>	Configure Custom P-state Table parameters	Enter	Enters sub-menu
<b>-Number of P-states</b>	Select the number of custom P-states.	[Number]	Set the number of custom P-states. At least 2 states must be present

### 3.2.9 System Agent (SA) Configuration

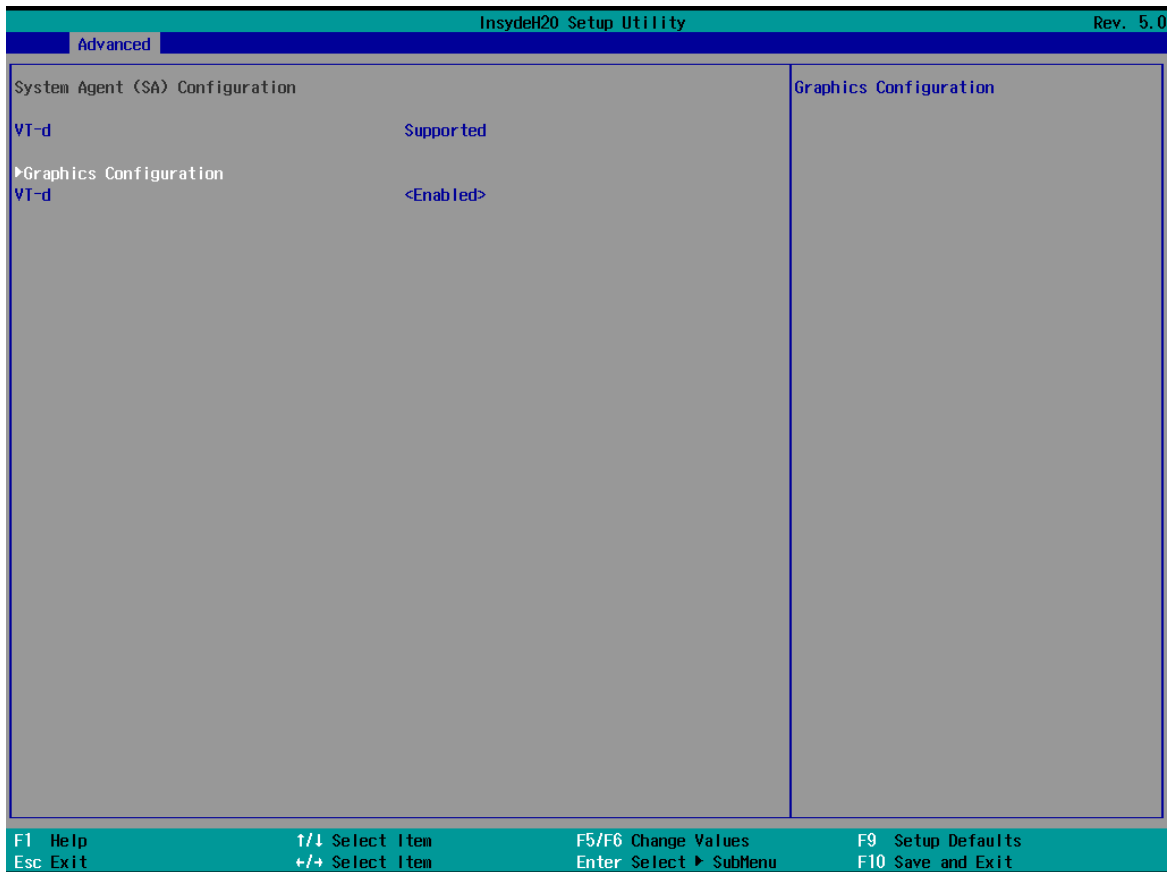

BIOS Setting	Description	Setting Option	Effect
<b>Graphics Configuration</b>	Configure Graphics Configuration parameters	Enter	Opens sub-menu
<b>Vt-d</b>	Intel® Virtualization Technology for Directed I/O	Enabled Disabled	Vt-d capability

### 3.2.10 Graphics Configuration

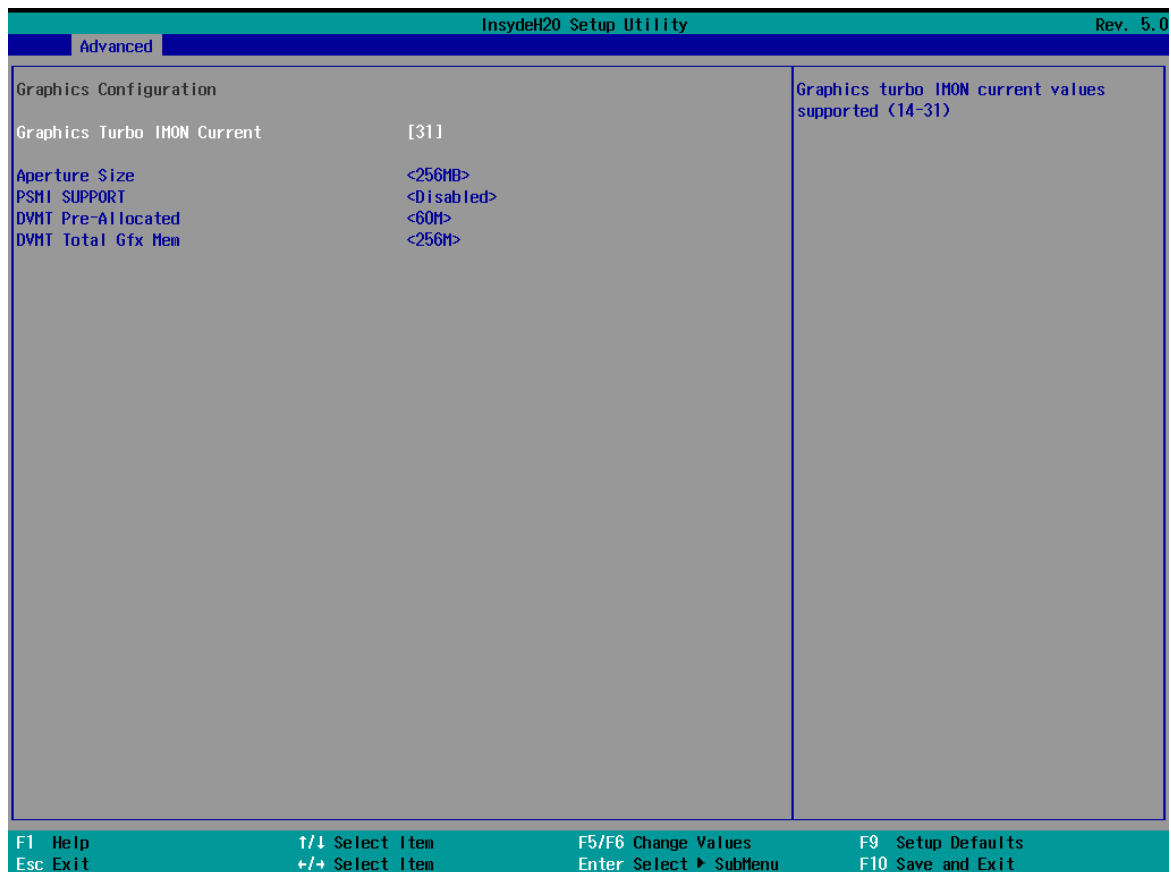

BIOS Setting	Description	Setting Option	Effect
<b>Internal Graphics</b>	Internal Graphics settings	Auto Enabled Disabled	Keep IGFX enabled based on the setup options
<b>Aperture Size</b>	Select the aperture size	128MB 256MB 512MB 1024MB 2048 MB	Select the aperture size <i>Note: Above 4MB MMIO BIOS assignment is automatically enabled when selecting 2048MB aperture. To use this feature please disable CSM port</i>

BIOS Setting	Description	Setting Option	Effect
<b>DVMT Pre-Allocated</b>	Select DVMT Pre-Allocated	0M~60M	Select DVMT 5.0 Pre-Allocated (Fixed) Graphic Memory size used by Internal Graphic Device

<b>DVMT Total Gfx Mem</b>	Select DVMT Total Gfx Mem	256M 128M MAX	Select DVMT 5.0 Total Graphic Memory size used by the Internal Graphic Device
<b>Gfx Low Power Mode</b>	Select Gfx Low Power Mode	Enabled/ Disabled	This option is applicable for SFF only

### 3.2.11 Boot

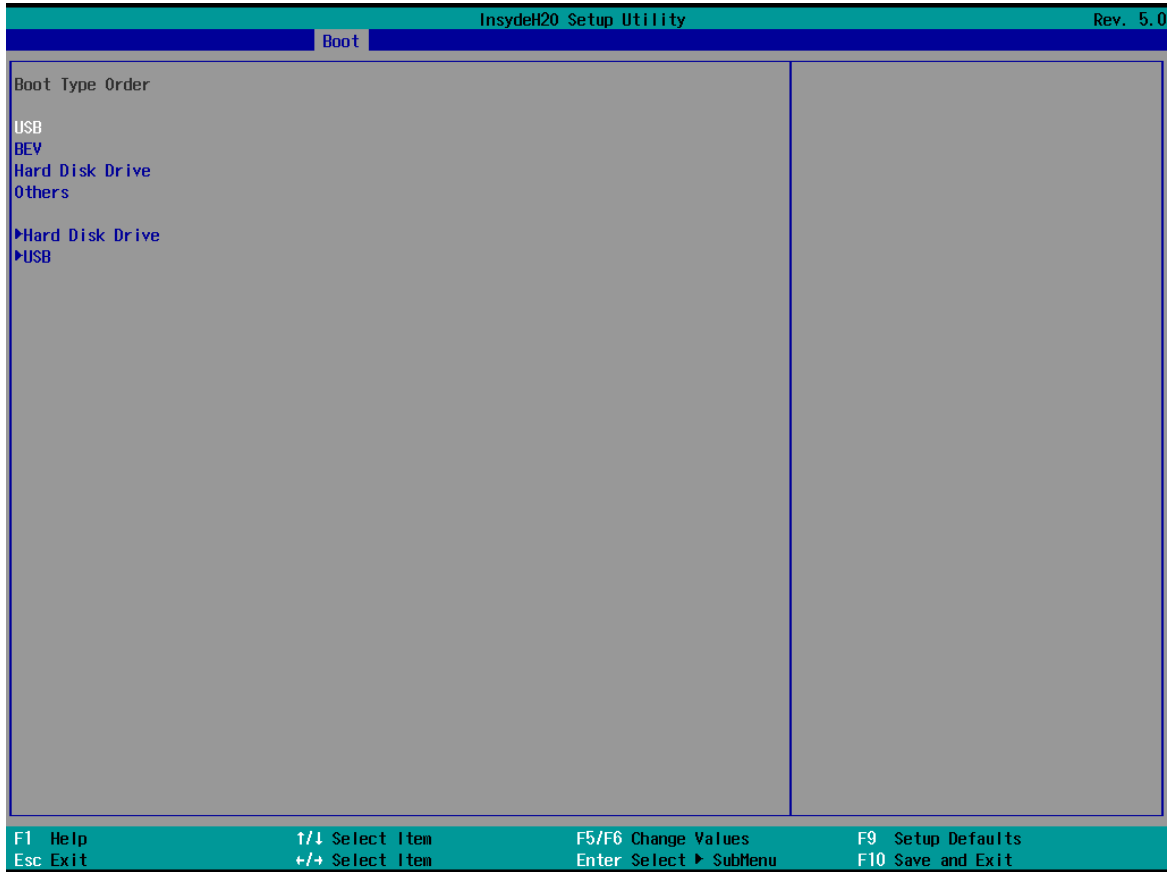

BIOS Setting	Description	Setting Option	Effect
<b>Boot Type</b>	Boot Type configuration	UEFI Boot Type	Select boot type to Dual type, Legacy type or UEFI type
<b>Quick Boot</b>	Quick Boot configuration	Enabled Disabled	Allows InsydeH20 to skip certain tests while booting. This will decrease the time needed to boot the system
<b>Quiet Boot</b>	Quiet Boot configuration	Enabled Disabled	Disable or enable booting in text Mode.
<b>Timeout</b>	Timeout	[Value]	Timeout settings
<b>Automatic Failover</b>		Enable	If boot to default device fail, it will directly try to boot next device
		Disable	If boot to default device fail, it will pop warning message then go to firmware UI
<b>Boot Type Order</b>	Boot Type Order	Enter	Opens sub-menu

### 3.2.12 Boot Type Order

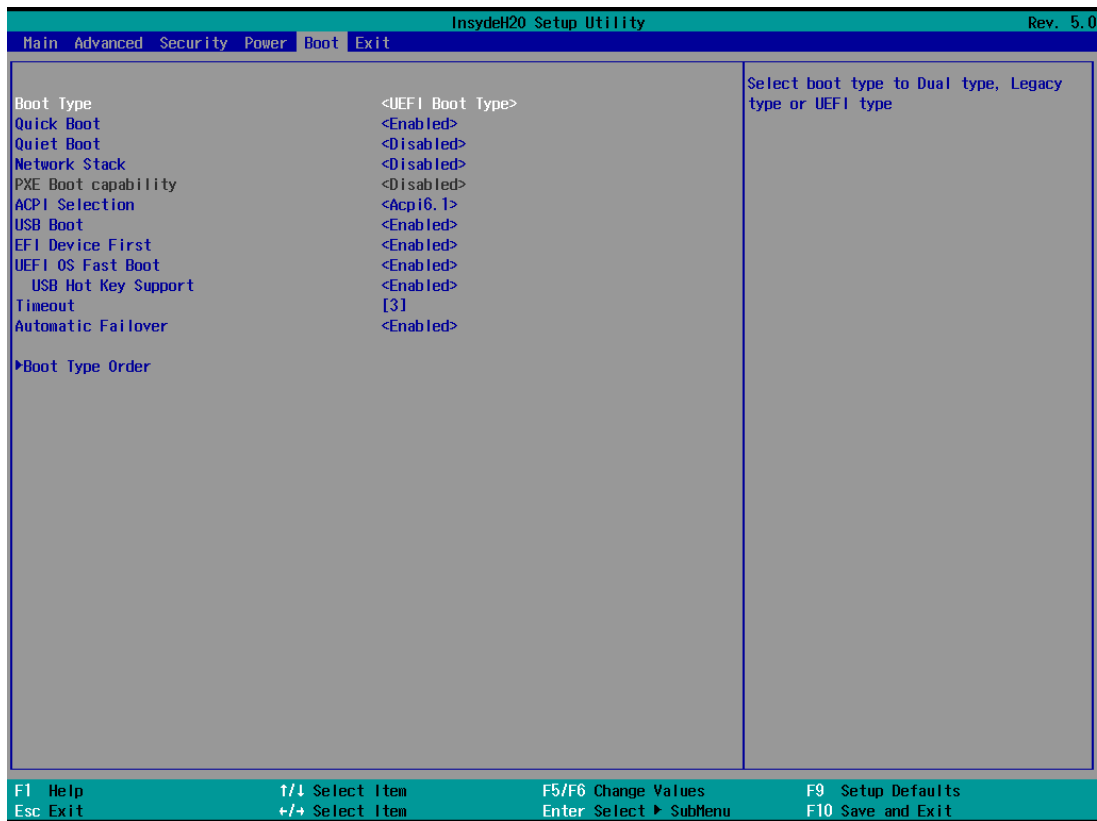

BIOS Setting	Description	Setting Option	Effect
<b>Hard Disk Type</b>	Hard Disk Type configuration	Enter	Opens Sub-menu
<b>Others</b>	Other configuration	Enter	Opens Sub-menu

### 3.2.13 Security

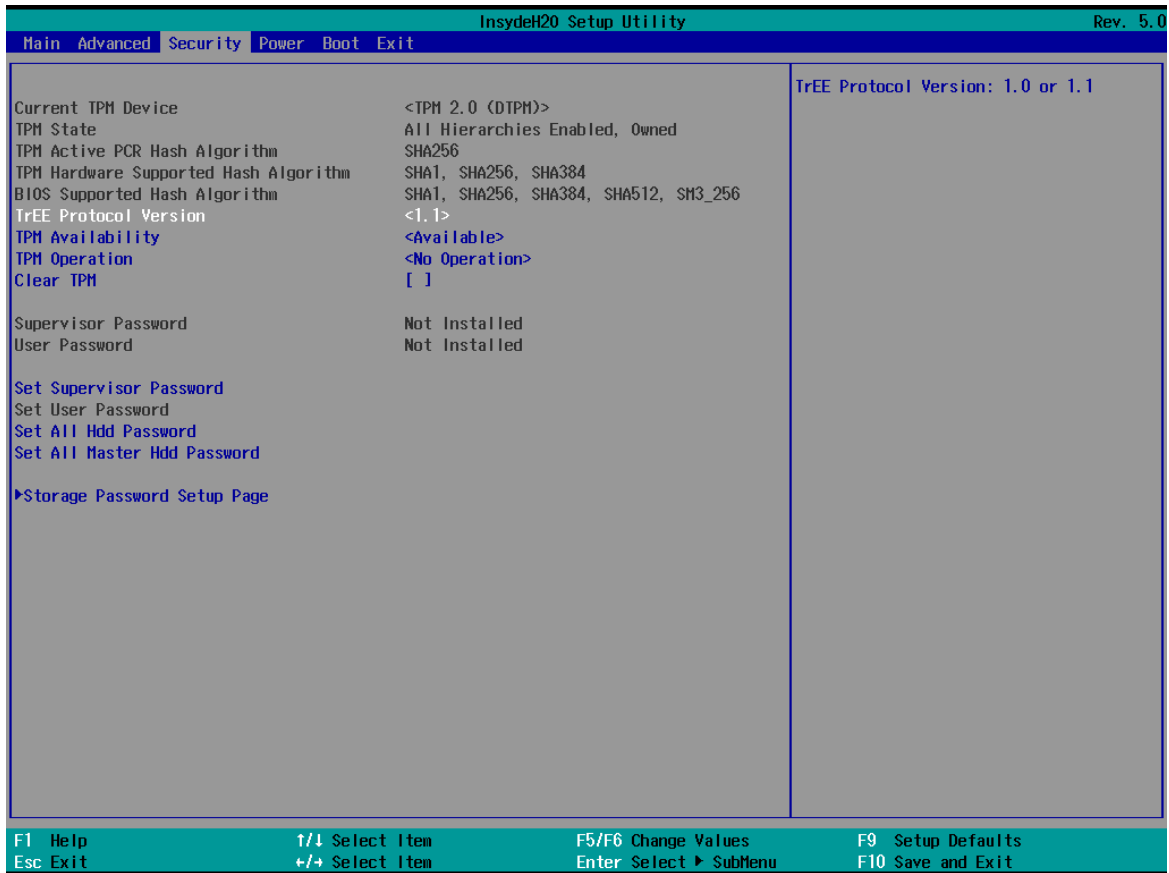

BIOS Setting	Description	Setting Option	Effect
<b>TrEE Protocol Version</b>	Choose TrEE Protocol Version	1.0 1.1	TrEE Protocol Version: 1.0 or 1.1
<b>TPM Availability</b>	TPM Availability configuration	Available Hidden	When hidden don't exposes TPM to 0
<b>TPM Operation</b>	TPM Operation configuration	[ ]	Select one of the supported operation to change TPM2state
<b>Clear TPM</b>	Clear TPM configuration	[ ]	Select to Clear TPM
<b>Set Supervisor Password</b>	Set Supervisor Password	Enter New password	Install or Change the password and the length of password must be greater than one character

### 3.2.14 Power



BIOS Setting	Description	Setting Option	Effect
<b>ACPI S3</b>	ACPI S3 configuration	Disabled Enabled	Enable/ Disable ACPI S1/S3 Sleep state
<b>Auto Wake on S5</b>	Auto Wake on S5 configuration	Disabled By Every Day By Every Month	Auto Wake on S5, by Day or Month or fixed time of every day

### 3.2.15 Exit

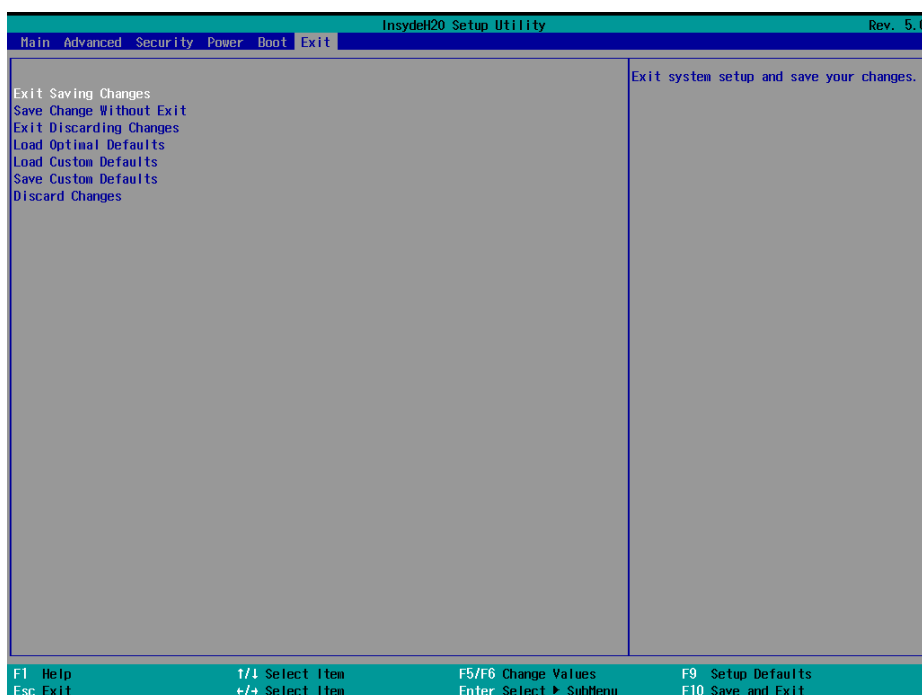

## 3.3 Using Recovery Wizard to Restore Computer

**Note:**

Before starting the recovery process, make sure to backup all user data. The data will be lost after the recovery process.

**Important:**

Before starting the recovery process, remove any expansion card.

To enable quick one-key recovery procedure:

1. Connect the computer to the power source. Make sure the computer stays plugged in to power source during the recovery process.
2. Turn on the computer, and when the boot screen shows up, press **F6** on the external USB keyboard to initiate the Recovery Wizard.
3. The following screen shows the Recovery Wizard. Click **Recovery** button to continue.



4. A warning message about data loss will show up. Make sure the data is backed up before recovery, and click Yes to continue.
5. During the recovery process, a command prompt will show up to indicate the percent of recovery process complete.
6. After the recovery process to complete, please restart your computer manually.

## Chapter 4: Driver Installation

This chapter contains driver installation guide. Follow the instructions below to complete the installation. You will quickly complete the installation. This chapter provides instructions on how to install drivers on the IE32 3.5" SBC.

4.1 Chipset Driver Installation

4.2 Graphic Driver Installation

4.3 Management Engine (ME)

4.4 SST Driver Installation

4.5 Audio Driver Installation

4.6 Ethernet Driver Installation

4.7 Watchdog Driver Installation

4.8 How to Enable Watchdog

4.9 Digital IO Driver Installation

4.10 Resistive Touch Driver for Windows 11 System



## 4.1 Chipset Driver

Follow instructions below to install Chipset driver.

1. Open the Driver (Download from Winmate Download Center) and select **Chipset** driver. When installation window will pop up, select **Next**.

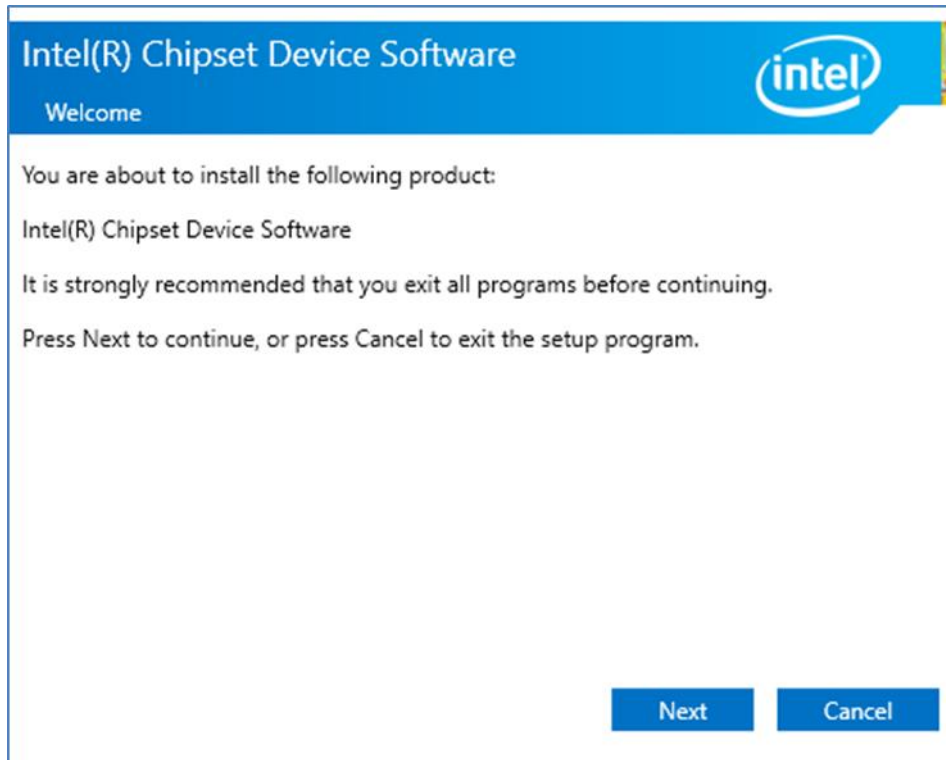

2. Select **Accept** to agree with the terms of license agreement.

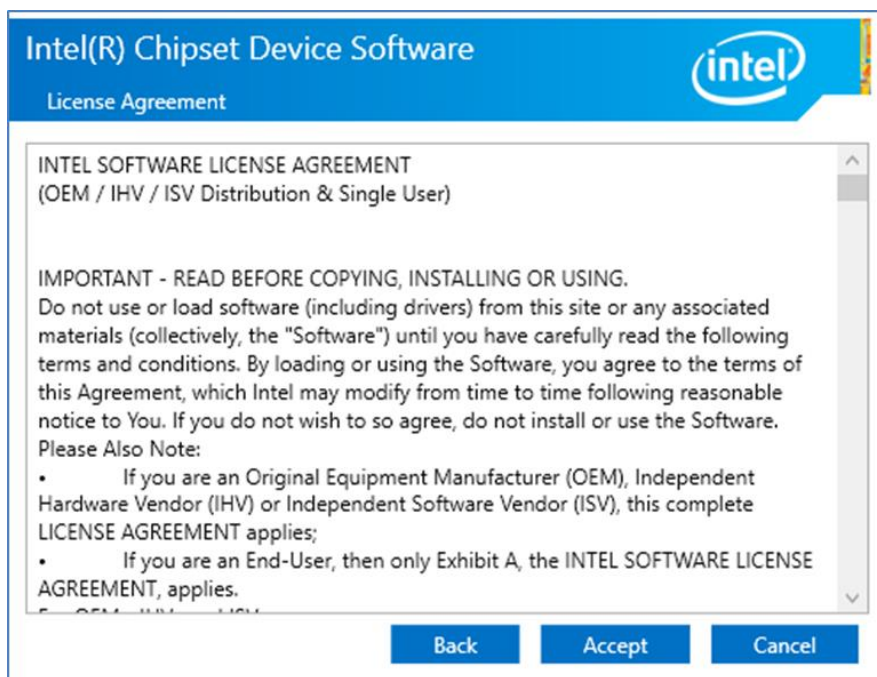

3. Check the ReadMe file information, select **Install** to continue.

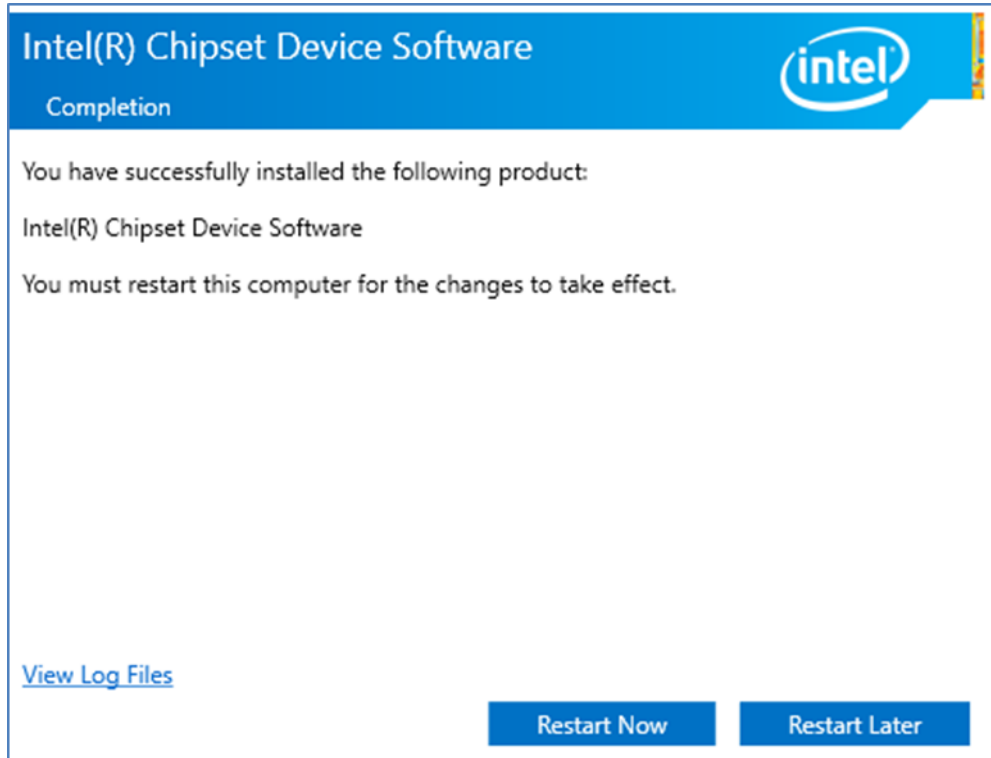

4. Wait for the driver to be installed. When installation completed, select **Restart Now** to restart your computer.



## 4.2 Graphic Driver

Follow instructions below to install Graphic driver.

1. Open the Driver (Download from Winmate Download Center) and select **Graphic** driver.

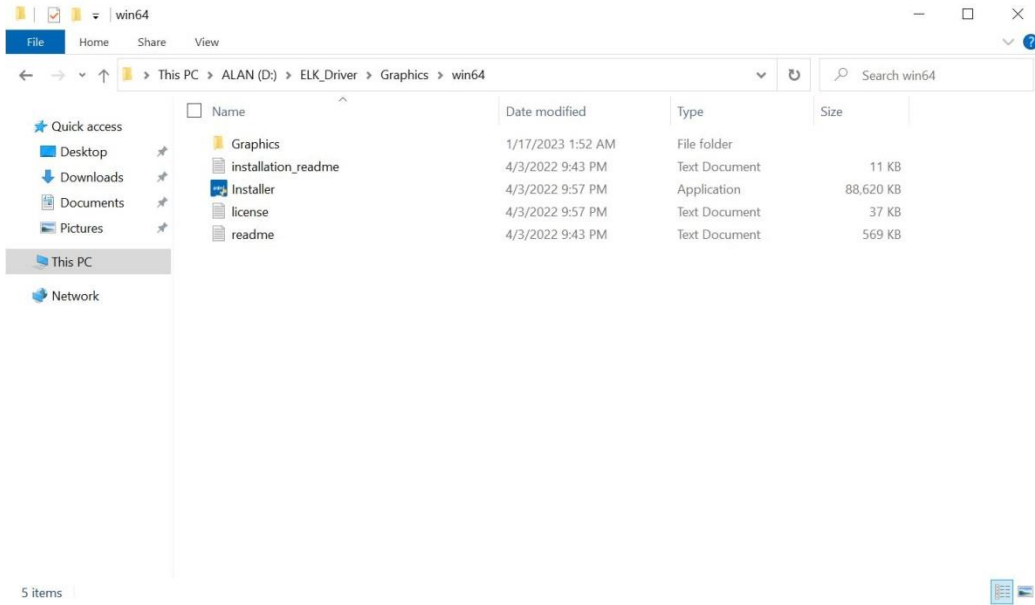

2. Installation window will pop up, select **Begin installation**.



### 3. Select I agree.

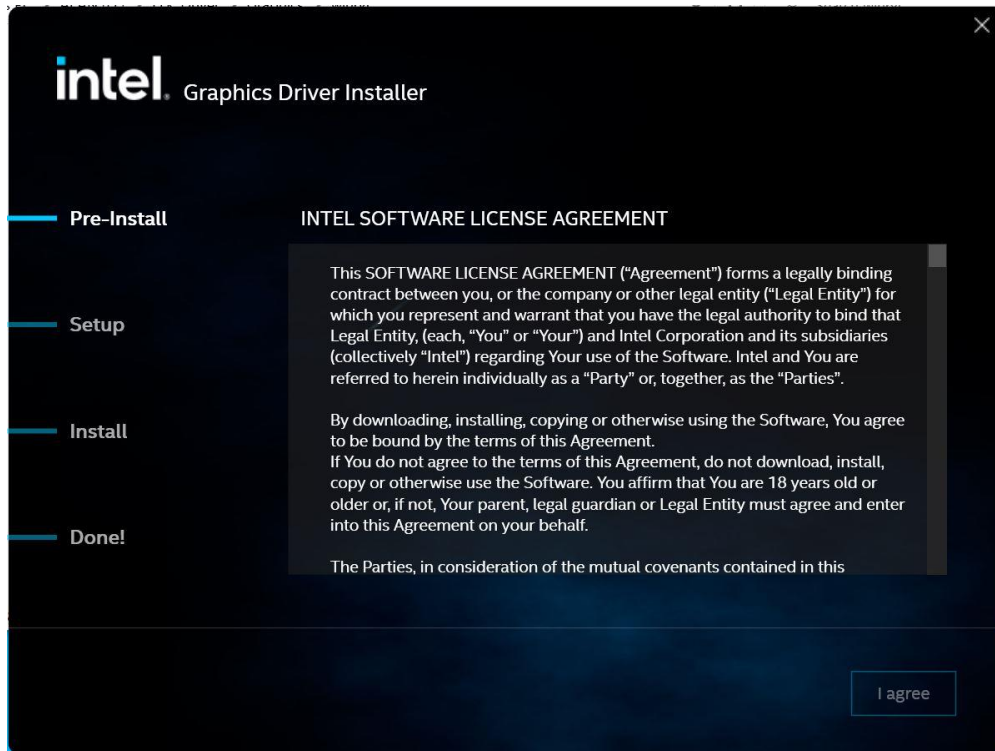

### 4. Select **Start** to install the Driver.

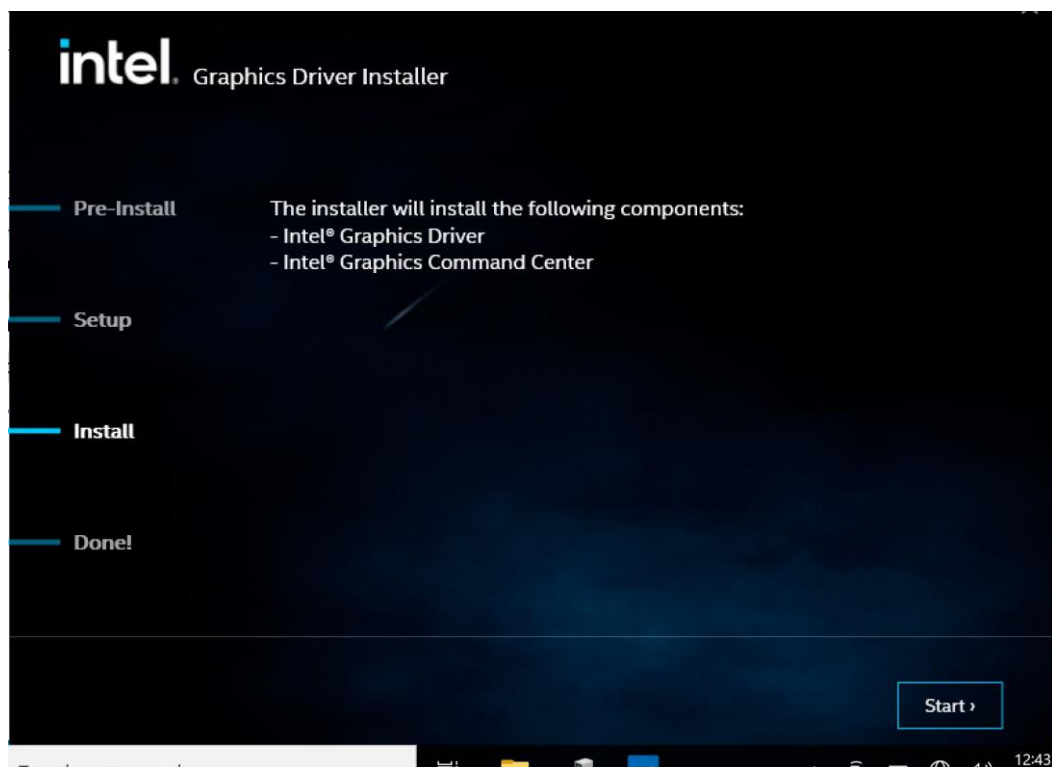

5. After installation is completed, click **Finish**.

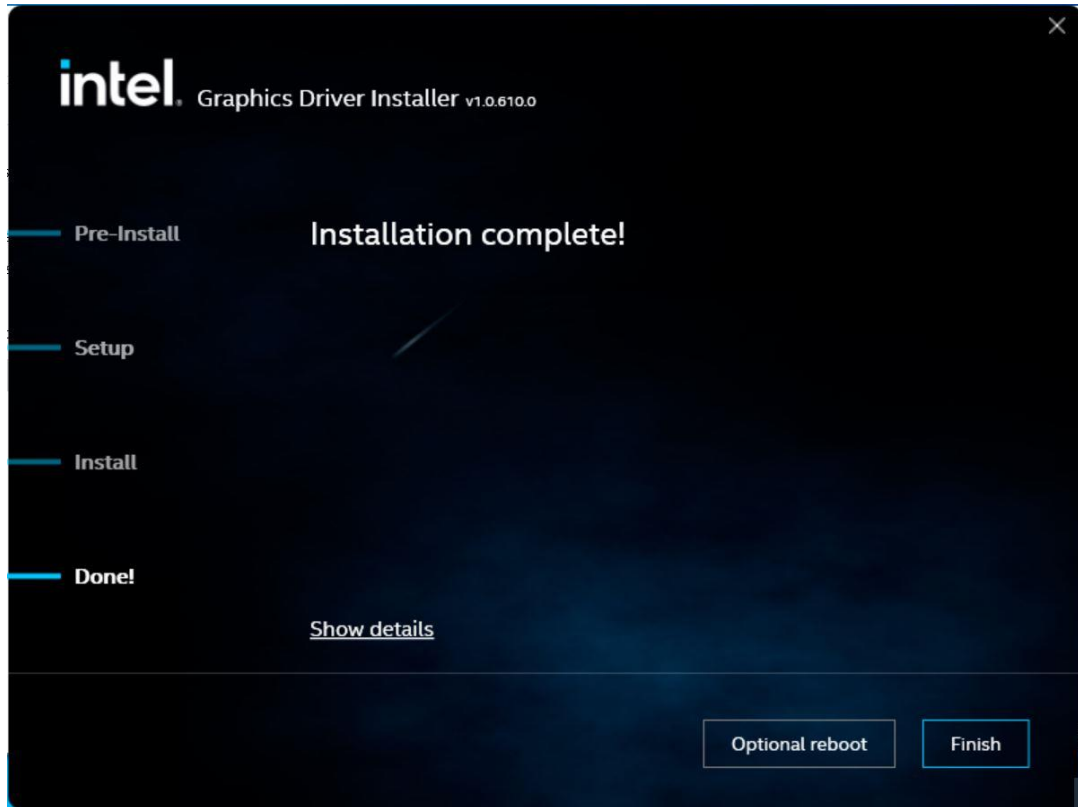

## 4.3 Management Engine (ME)

Follow instructions below to install Management Engine (ME) .

1. Open the Driver (Download from Winmate Download Center) and select **ME** driver.

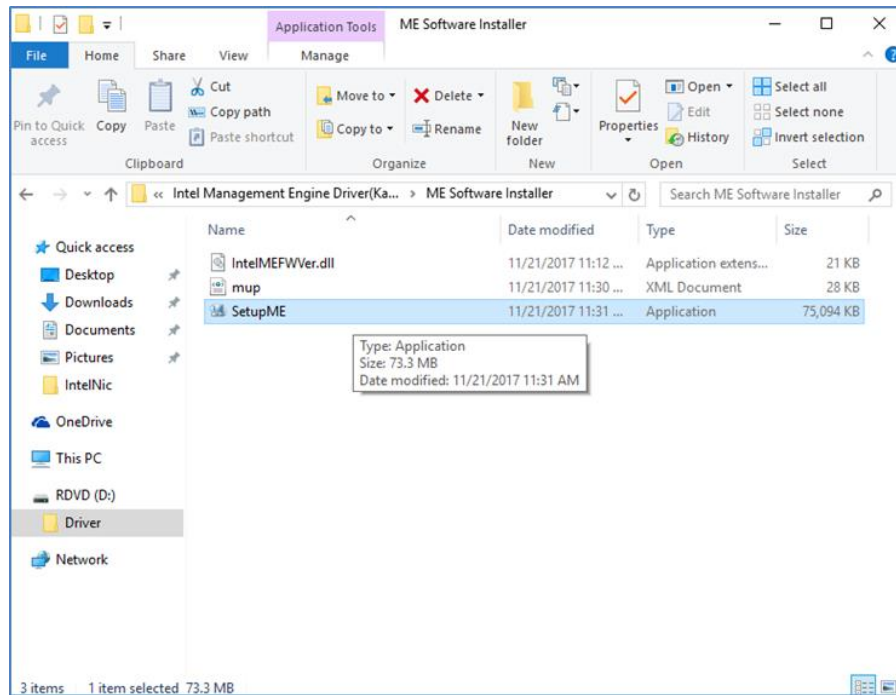

2. Select **Next** to start the installation.

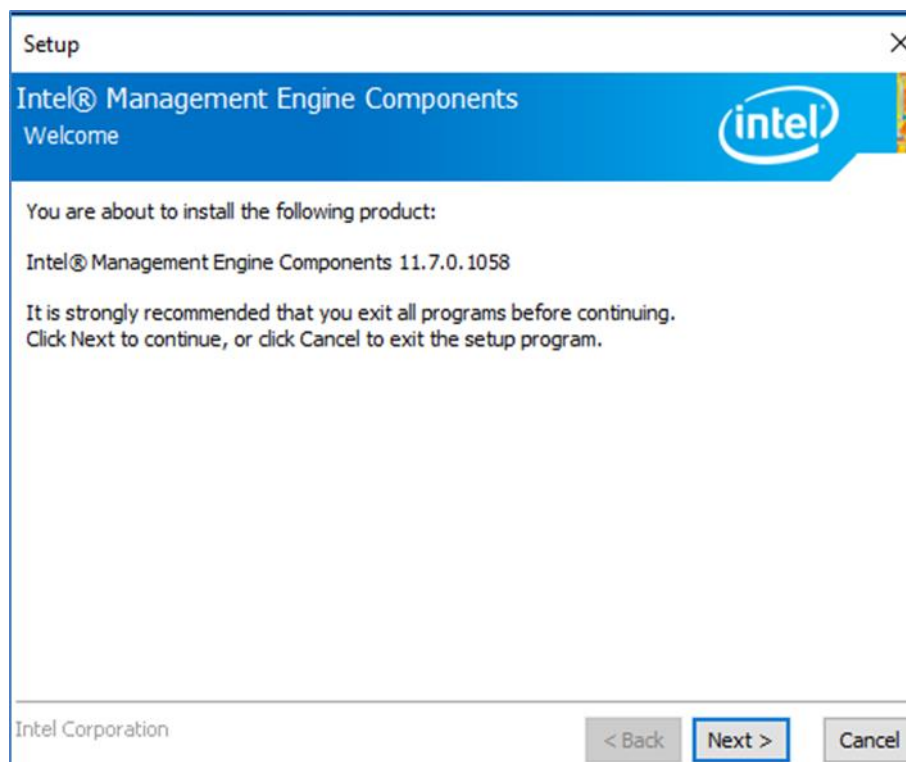

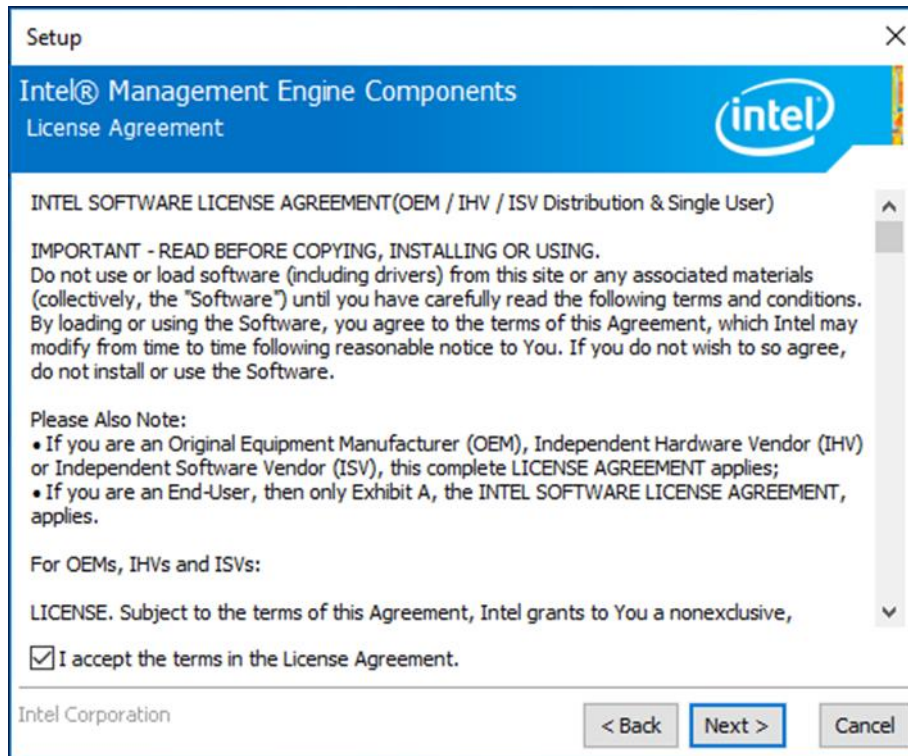
3. Select **Next** to agree with the terms of license agreement.

## 4. Wait for the driver to be installed.

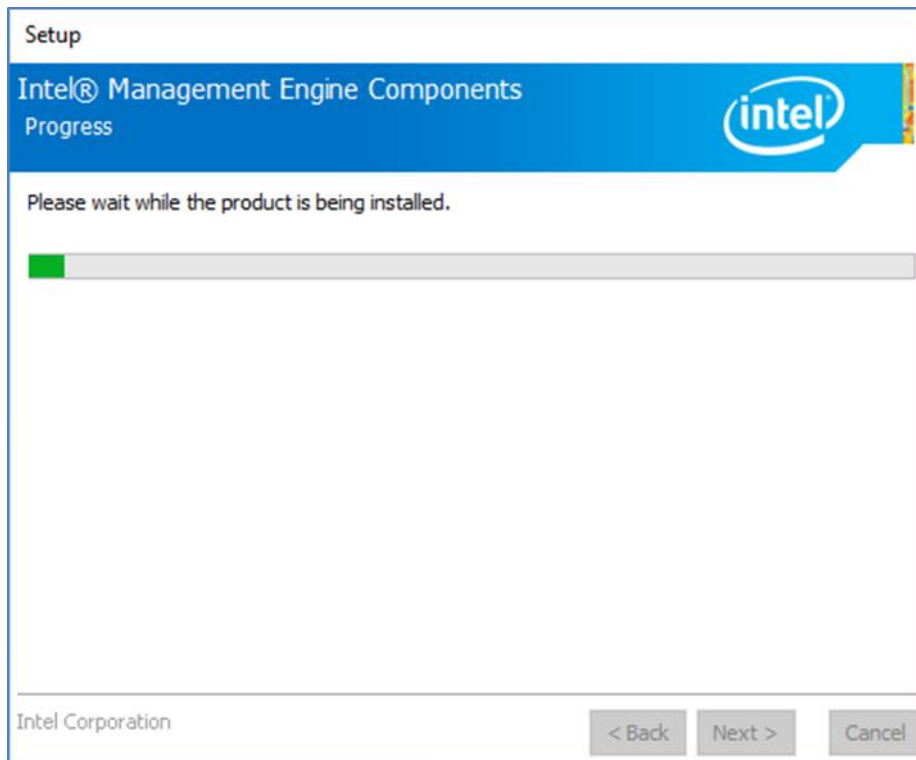

5. When installation completed, select **Finish** complete installation.

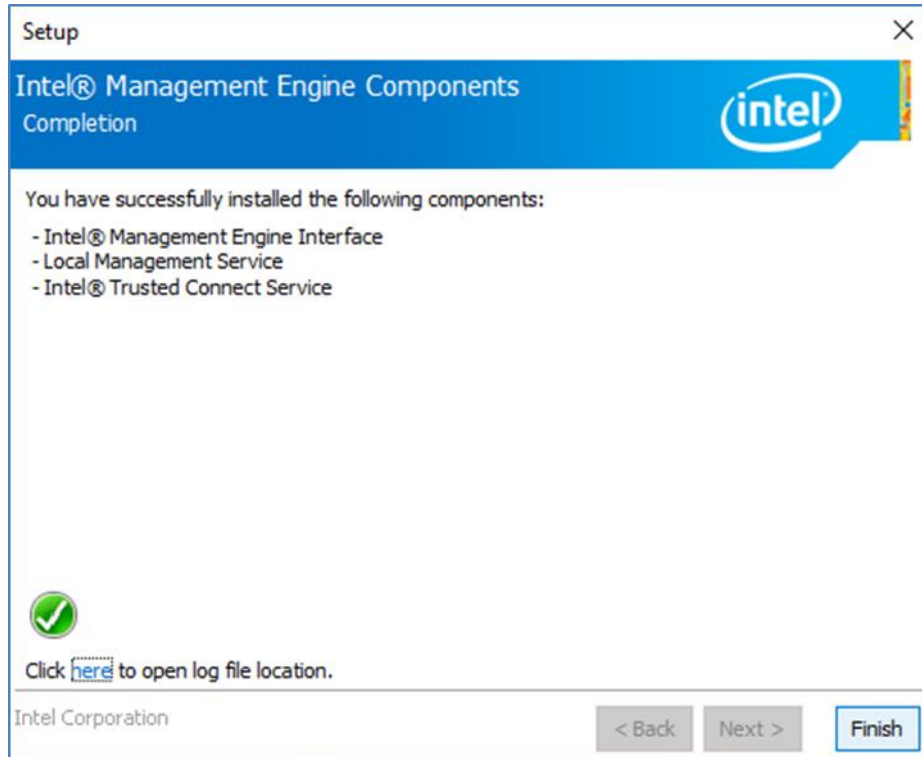

## 4.4 SST Driver

Follow instructions below to install SST driver.

1. Update Drivers > Browse "My computer" for driver software > Next

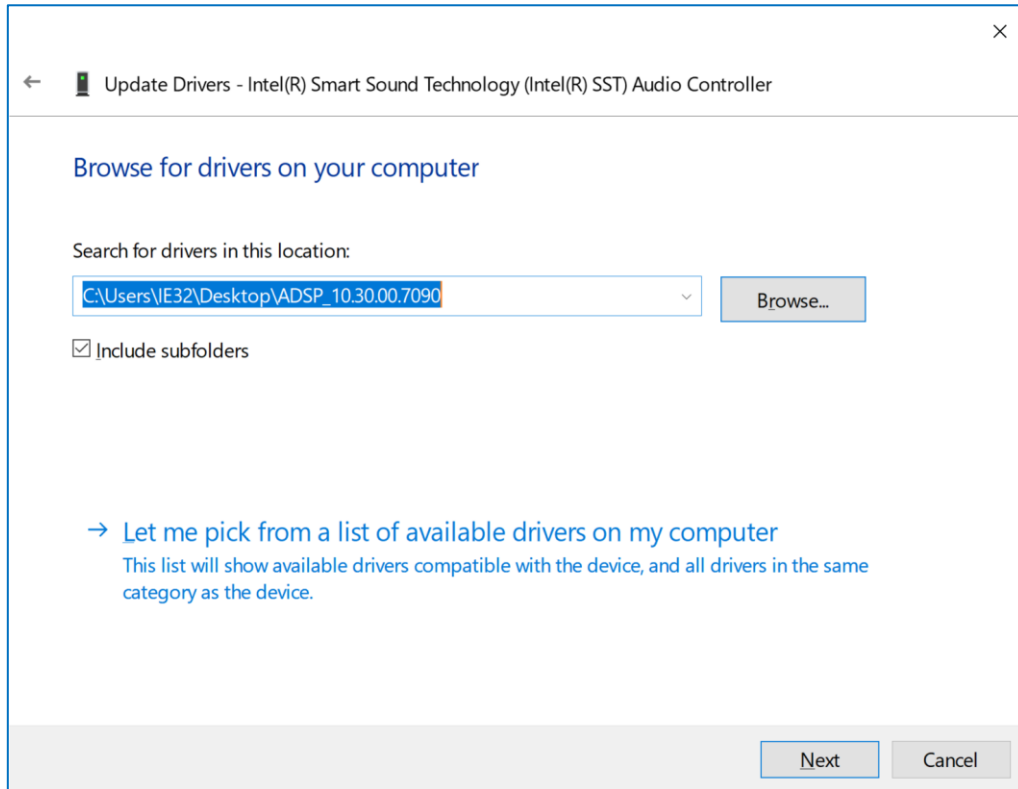

2. Wait for driver installation to complete.

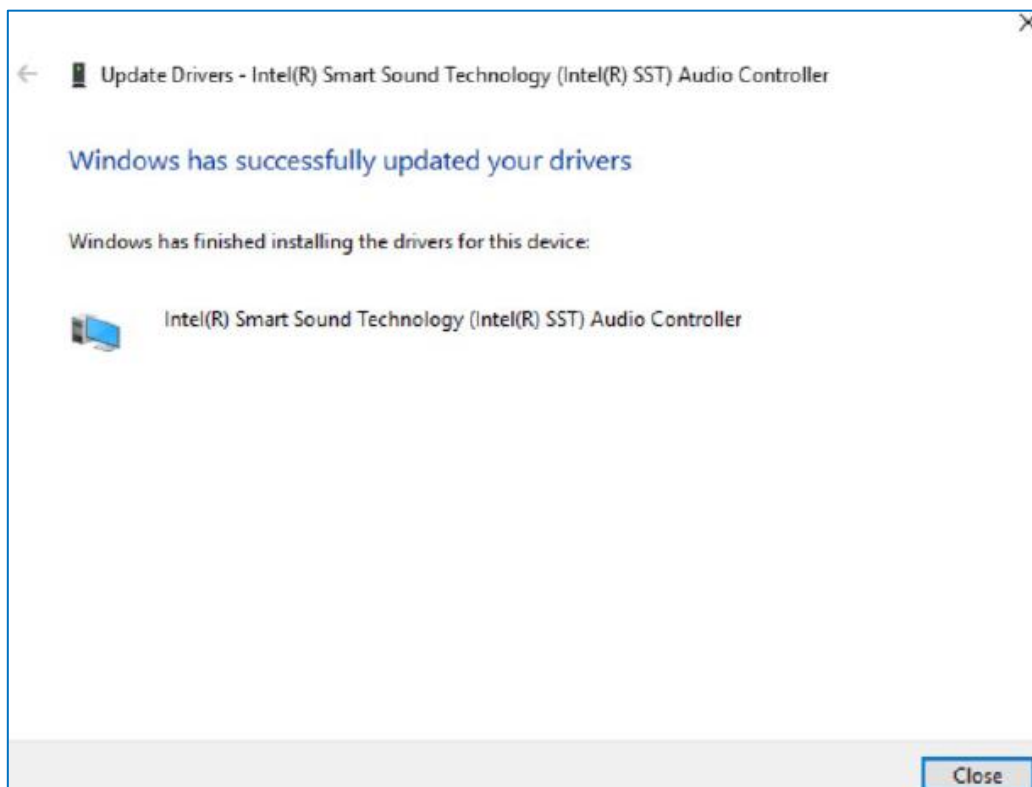

**Note:**

This product is equipped with SST Driver, when the line-in function of Audio is used, the product will automatically enter D3 sleep mode. To solve this problem, you must enter the line in setting and turn on the sync output. When the sync output setting is turned on, the line-out will output the sound synchronously.

Therefore, if you only need to use the line-in function, please turn off the volume of the line-out device. When the line-out volume is turned off, HDMI will also have no audio output. If you will not use the line-in function, please keep the Winmate default setting. When you need to use the line-in function, please follow the steps below to turn on the sync output.

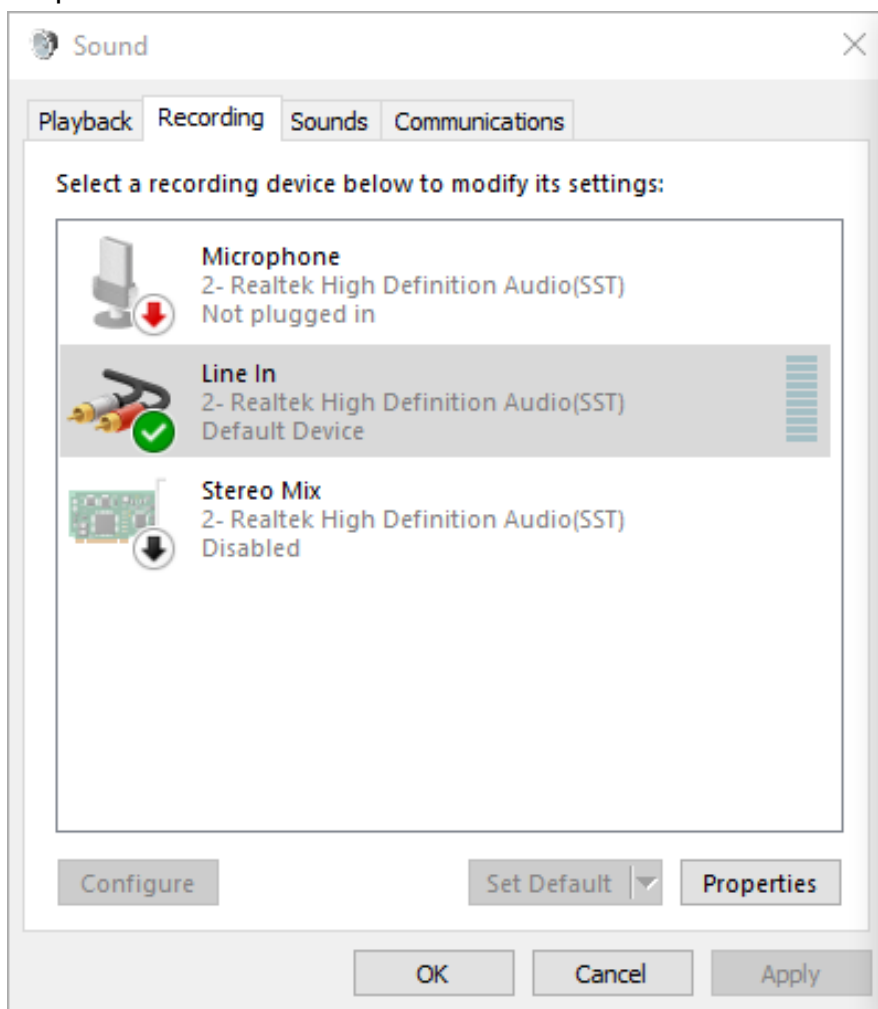
**Step 1:****Step 2:**

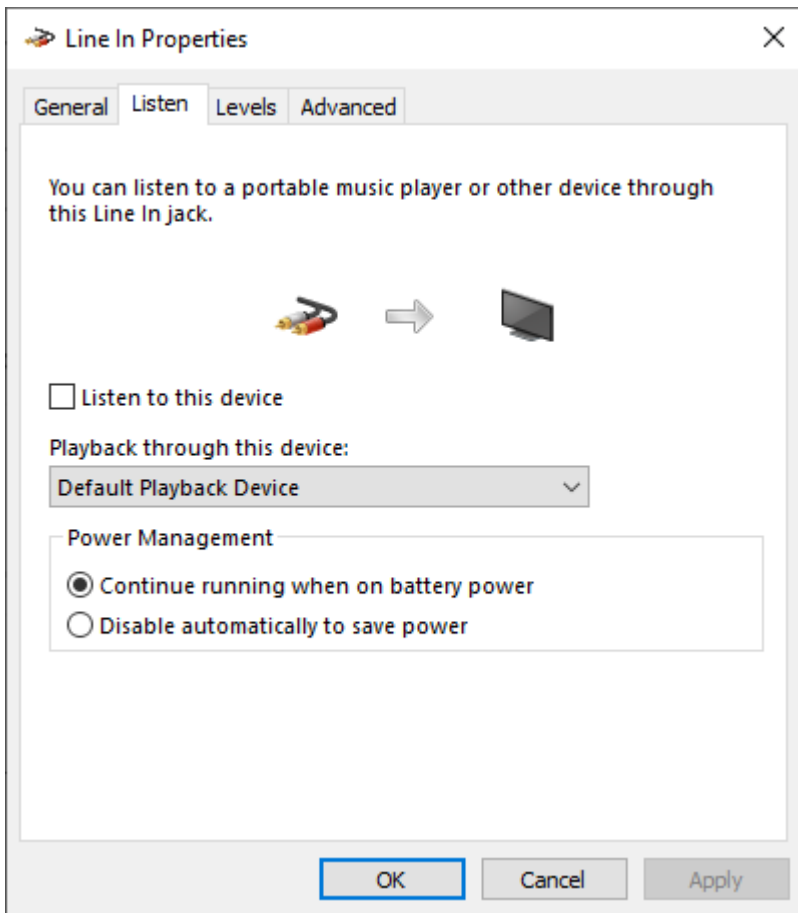

## 4.5 Audio Driver

Follow instructions below to install Audio driver.

1. Open the Driver (Download from Winmate Download Center) and select **Audio** driver.

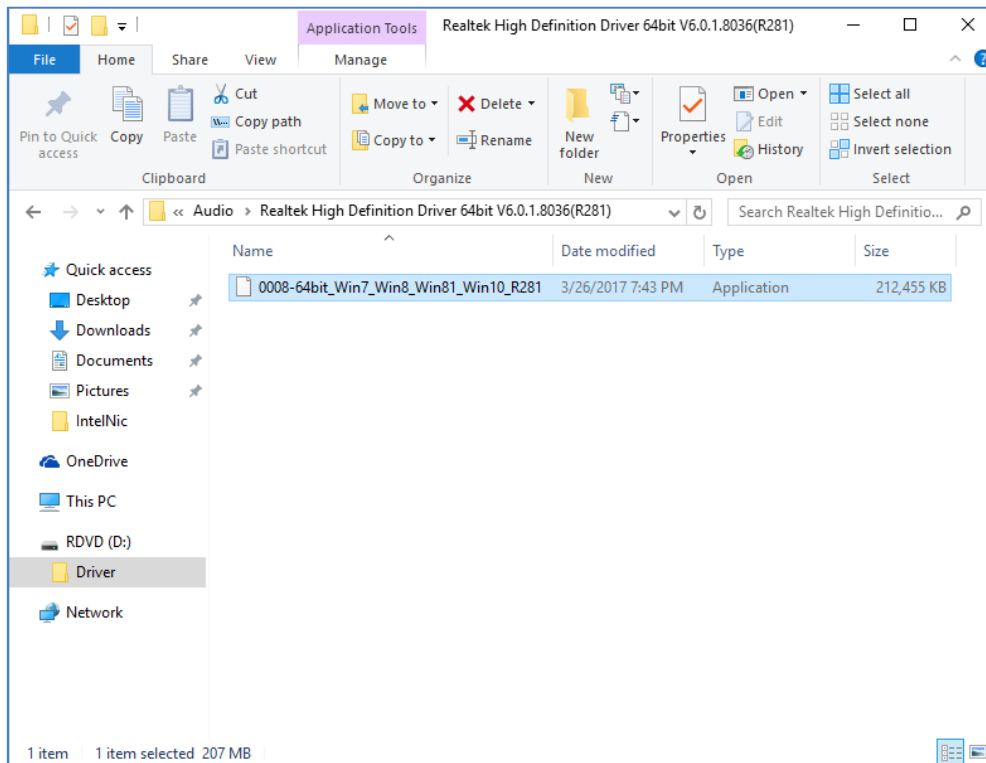

2. Select **Next** to continue.



3. When installation completed, select **Finish** complete installation.



## 4.6 Ethernet Driver

Follow instructions below to install LAN driver.

1. Open the Driver (Download from Winmate Download Center) and select **LAN** driver.

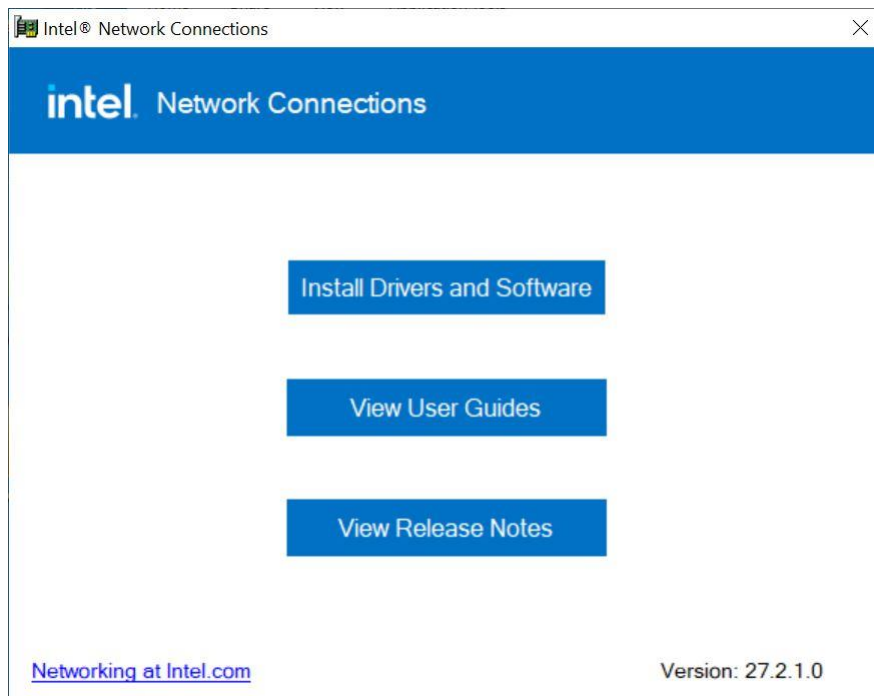
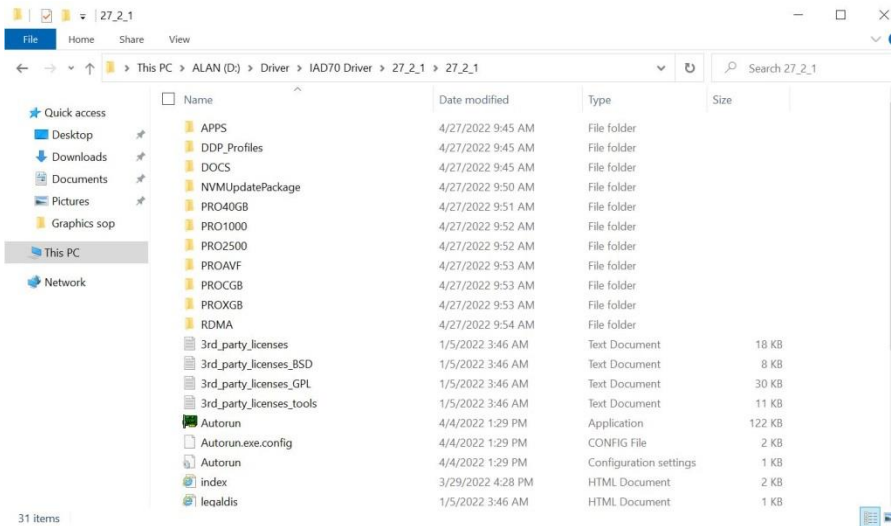

2. When compression is complete, select **Next**.

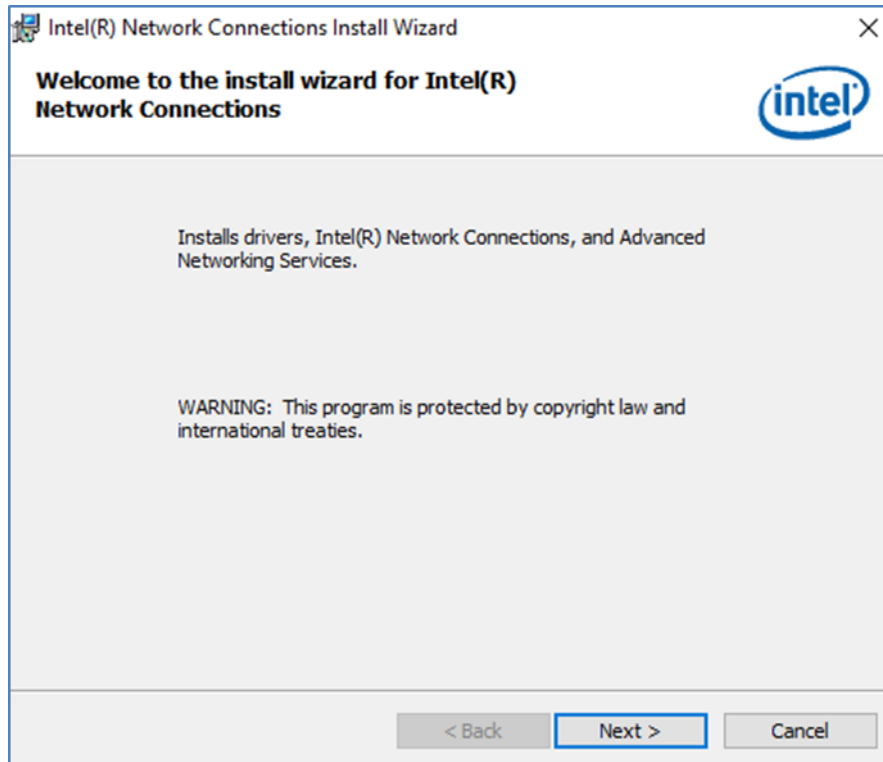

3. Read the license agreement, and then select **Next**.

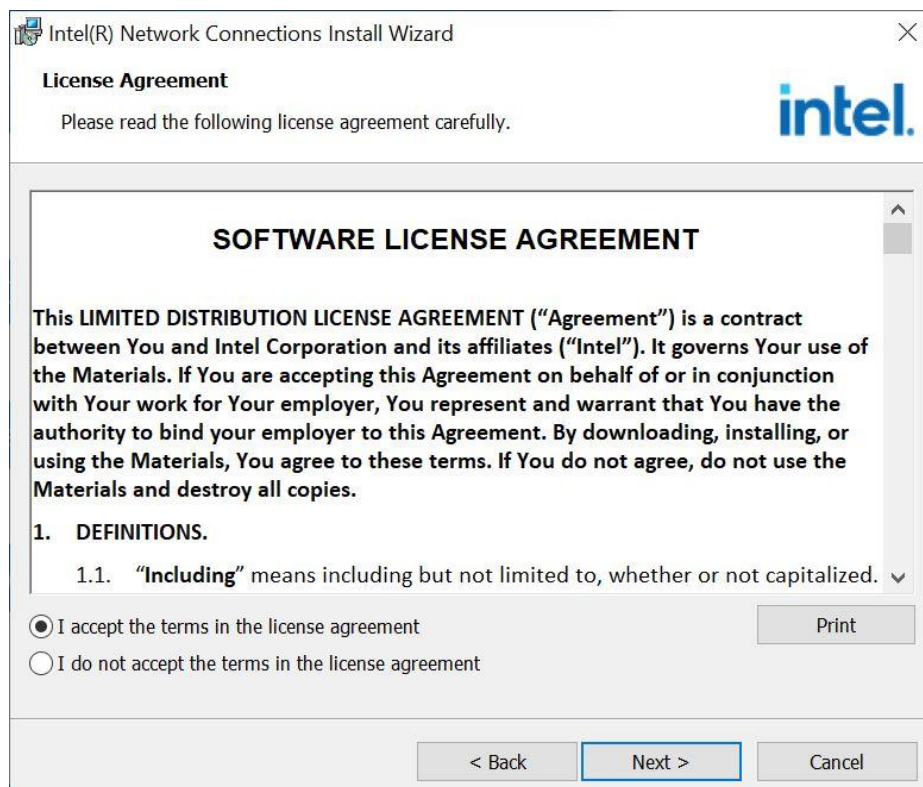

4. Select the program you want to install and select **Next**.

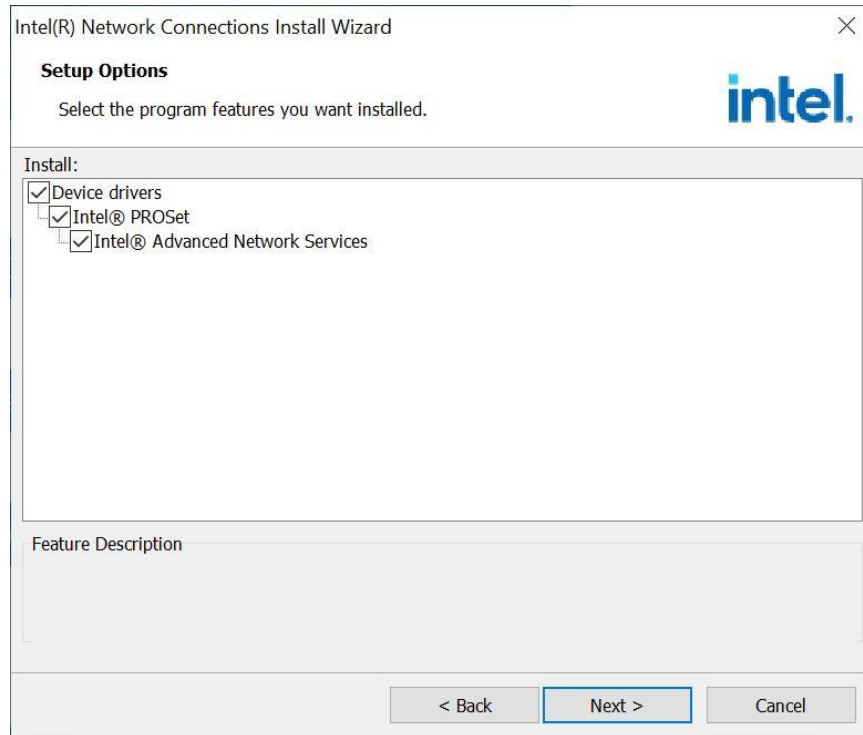

5. Confirm the installation, select **Install** to start the installation.

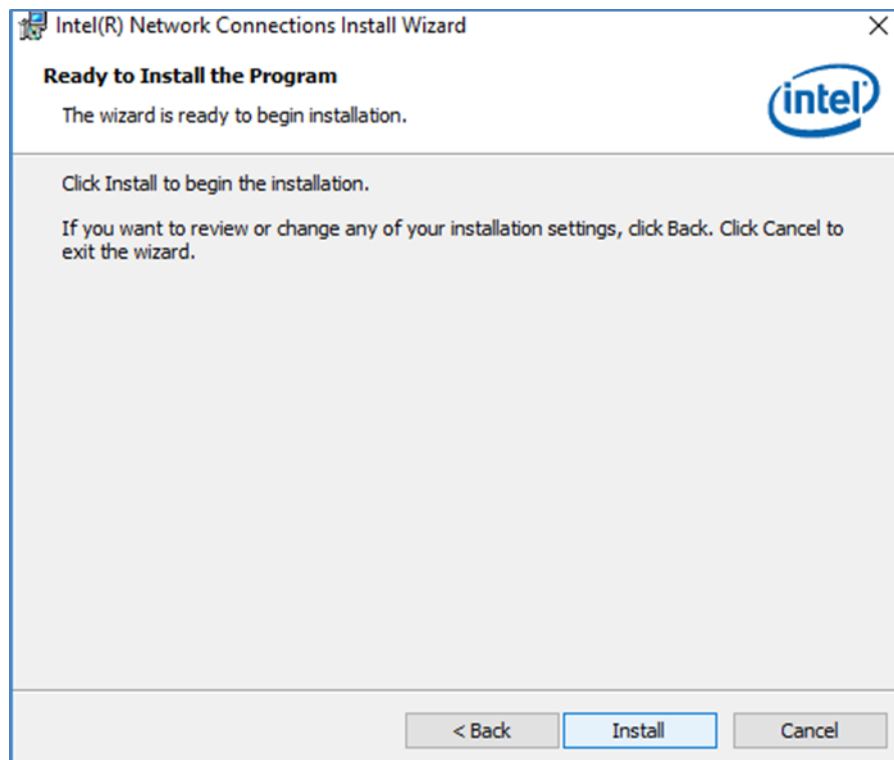

6. When installation is completed, select **Finish** to close the window.

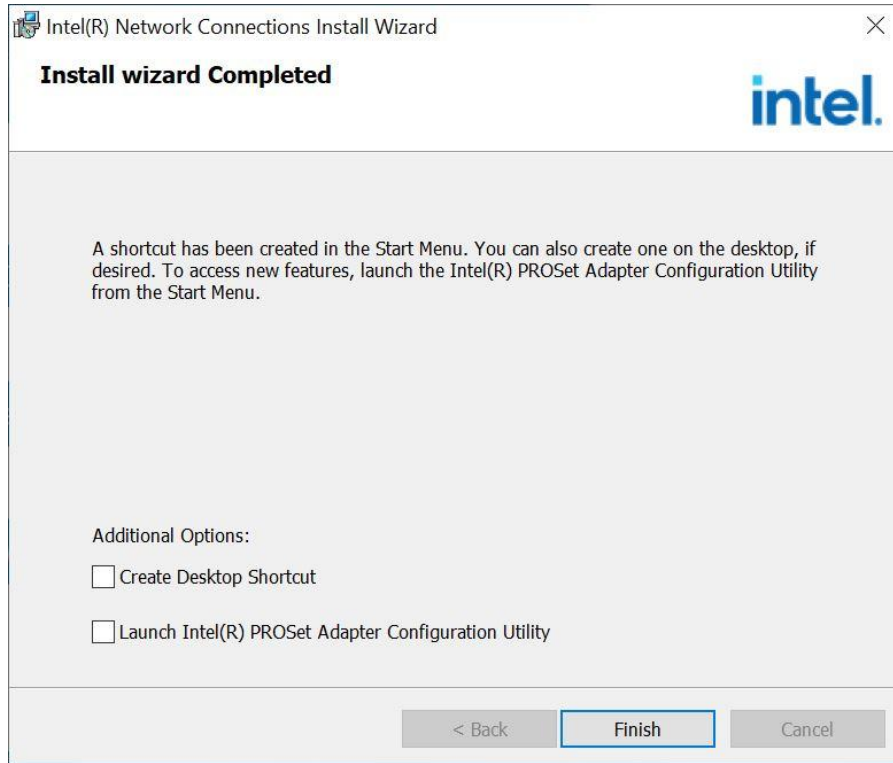

## 4.7 Watchdog Driver

For more details about Winmate Watchdog, please download Watchdog Guide from Winmate Downloads Center:

Follow instructions below to install **Watchdog** driver.

1. Type “cmd” in the run box then the cmd.exe will appear in programs.
2. Right click on the cmd.exe and click on “Run as administrator” to start

Open the Driver (Download from Winmate Download Center) and select Watchdog driver.

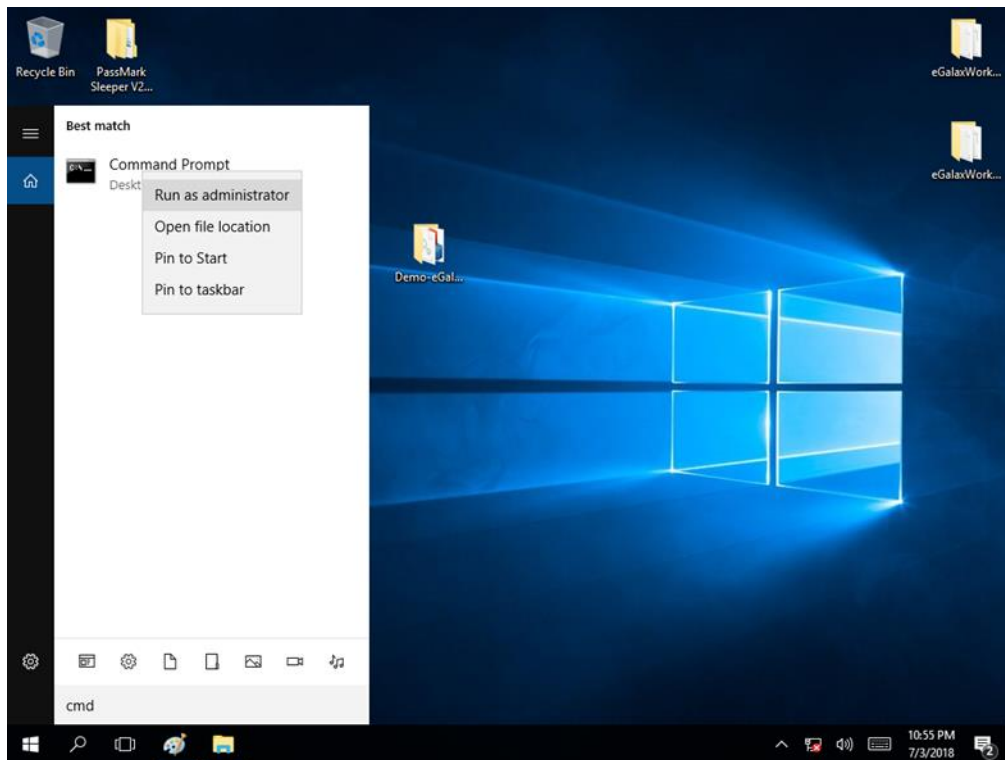

- When Windows Security dialog appear, select install to continue the Installation.

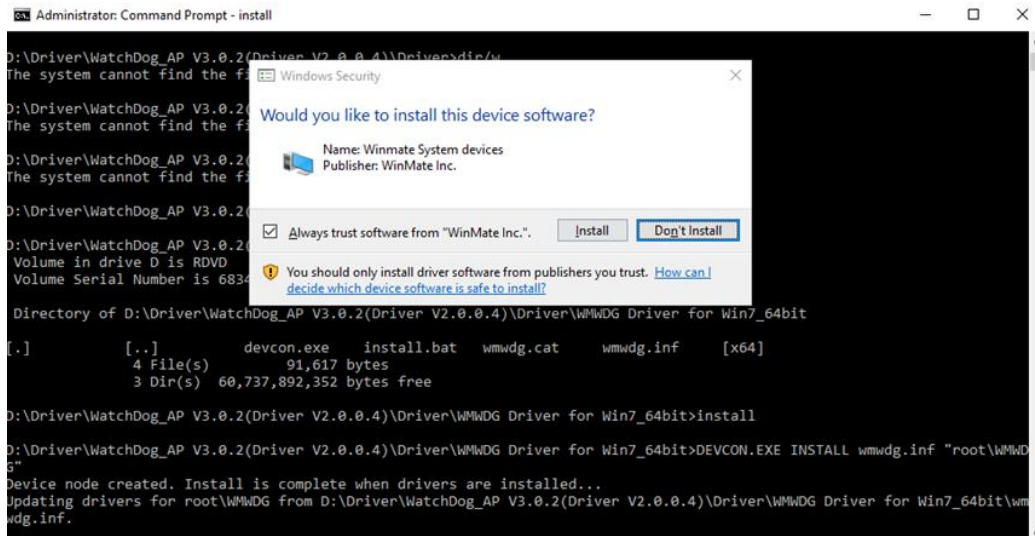

- Wait for installation to complete. When installation is complete, press any key to close.

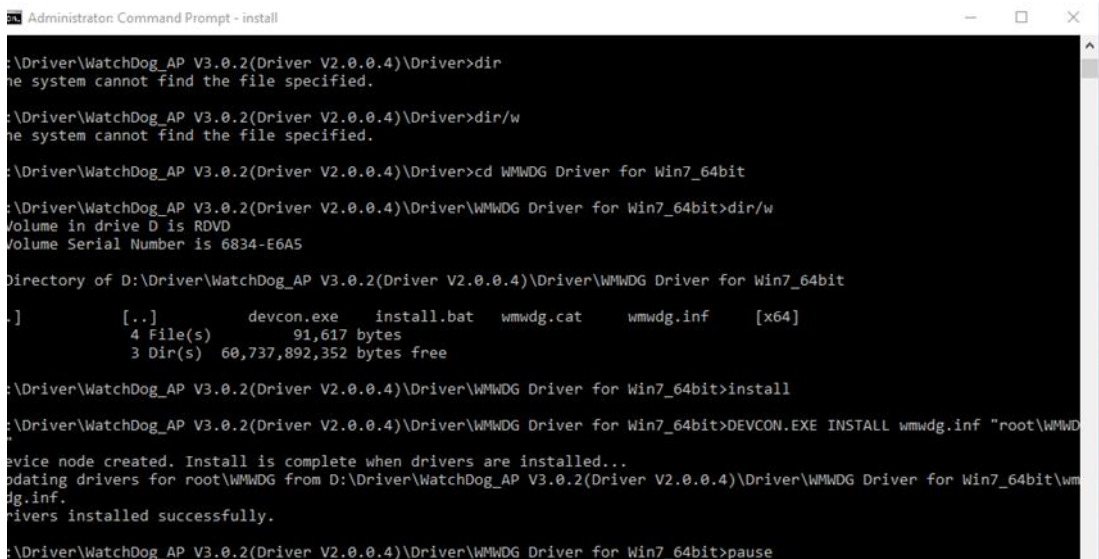

5. Open the Driver and select **Watchdog AP**.

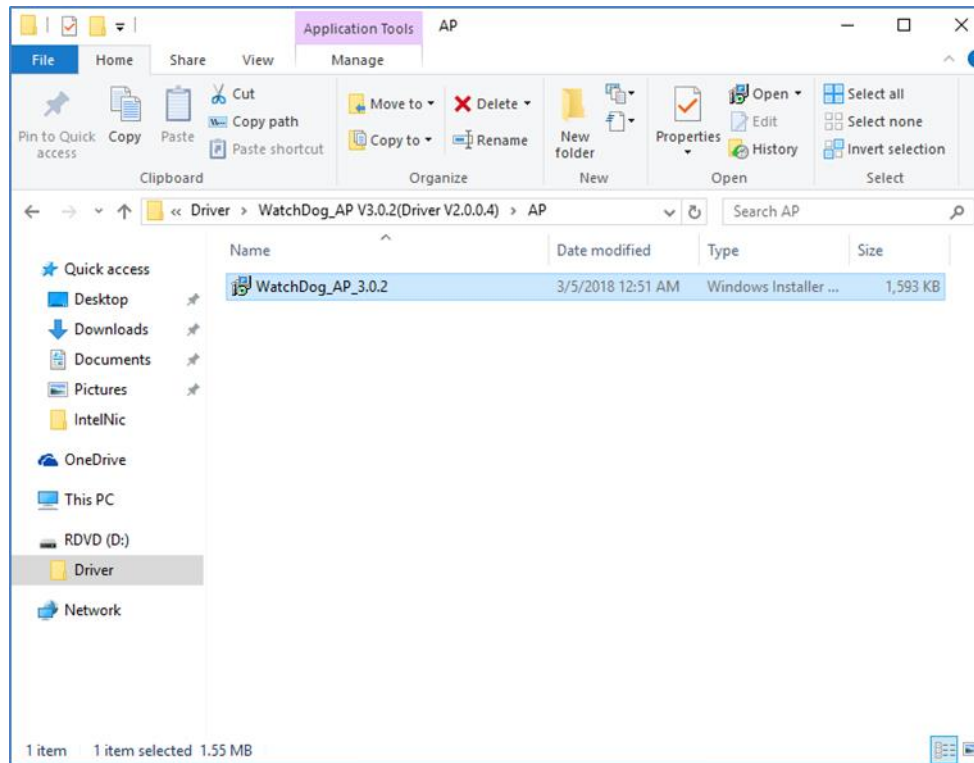

6. Select **Next**.



7. The installed storage location is displayed, select **Next** to continue.

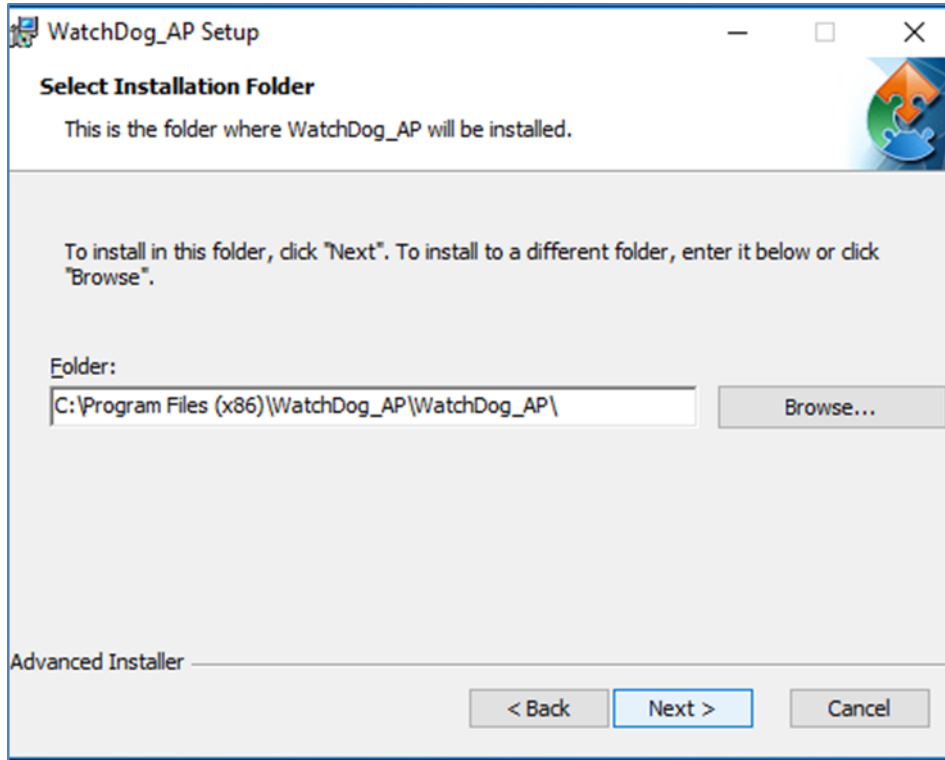

8. Select **Next** to start the installation.

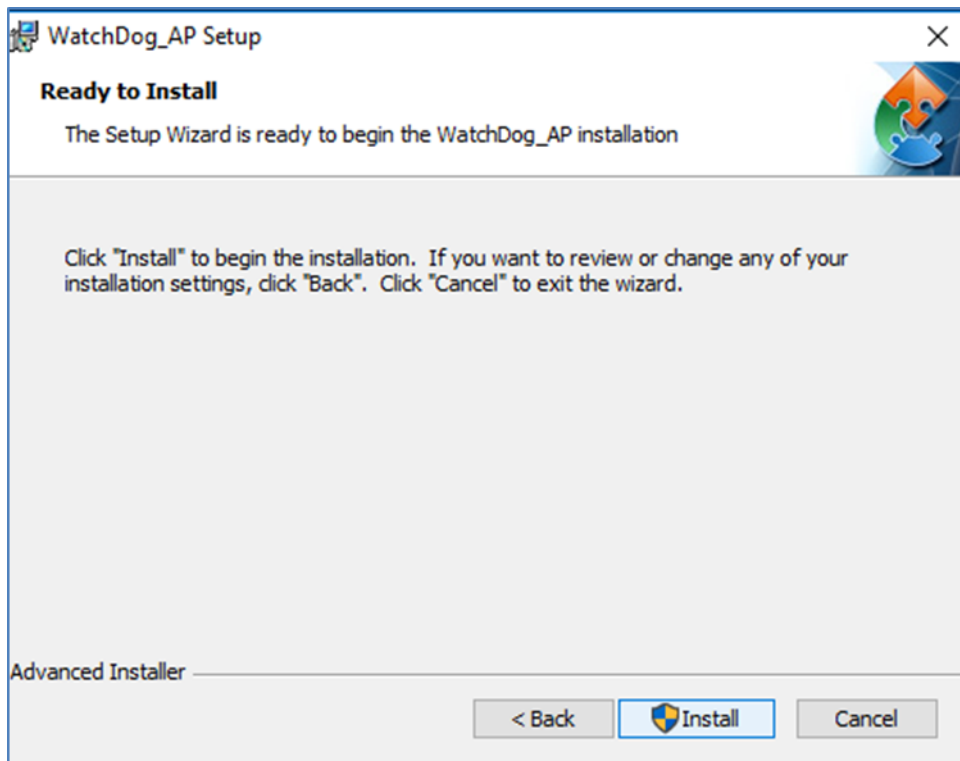



9. When installation is completed, select **Finish** to close the window.



## 4.8 How to Enable Watchdog

To enable Watchdog, you need to download Winmate Watchdog utility. Find more information on Watchdog in "Watchdog Guide" that you can download from Winmate Download Center or File Share. Refer to the User Manual for more details.

To enable watchdog in Watchdog AP follow the instructions below:

1. On the right bottom side of the desktop screen, click  **triangle button** to show hidden icons.
2. Click  icon to open Watchdog utility.

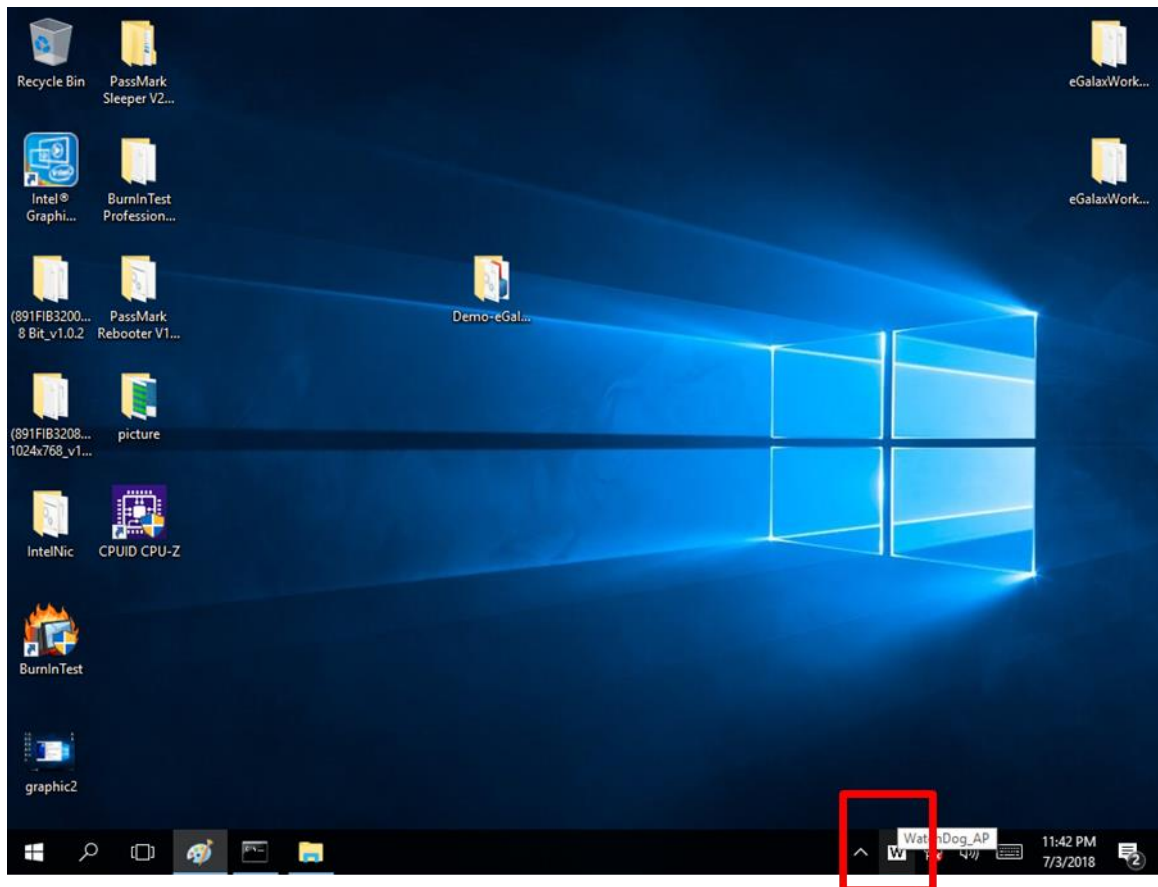

3. In Watchdog utility window set countdown time and periodically feed time, or disable watchdog.

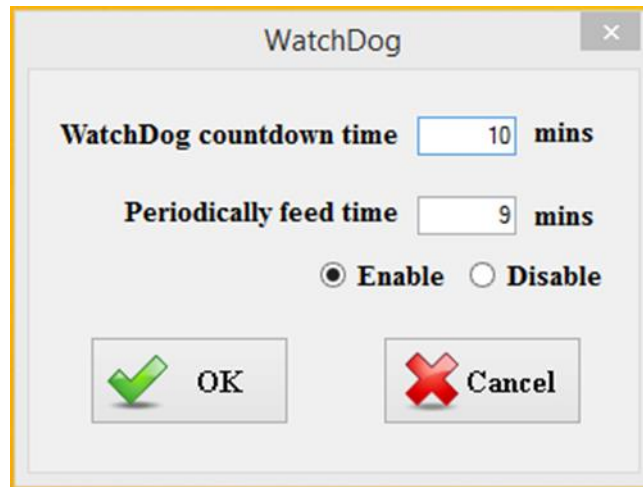

Setting	Description
<b>Watchdog Countdown Time</b>	The system automaticity restarts when this countdown time reaches zero. <i>Default: 10 min</i>
<b>Periodically Feed Time</b>	To set a cycle time to automatically reset watchdog timer. <i>Default: 9 min</i>
<b>Enable / Disable</b>	Enable or disable watchdog. <i>Default: Enable</i>

### Example:

Every 10 min watchdog will monitor the system, in case any error occurs the system will restart automatically when the countdown time reaches 0.

Every 9 min watchdog timer will be reset to 10

## 4.9 Digital IO Driver

For more details about Winmate Watchdog, please download Digital IO Guide from Winmate Downloads Center:

Follow instructions below to install **Digital IO** driver.

1. Type "cmd" in the run box then the cmd.exe will appear in programs.
2. Right click on the cmd.exe and click on "Run as administrator" to start.

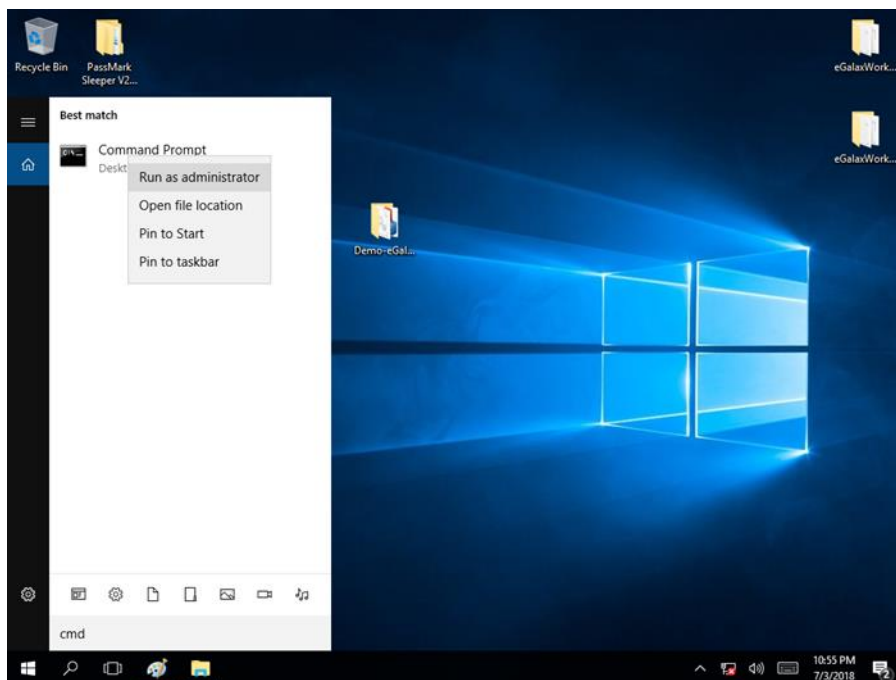

3. Open the Driver and select Digital IO driver.
4. When Windows Security dialog appear, select install to continue the Installation.
5. Wait for installation to complete. When installation is complete, press any key to close.

```
Administrator: Command Prompt
[.]
WMDIO 64bit Driver Installation Guide v101.pdf      WMDIO Driver for Win7_32bit.zip
WMDIO Driver for Win7_64bit.zip
          3 File(s)      227,270 bytes
          2 Dir(s)      60,734,410,752 bytes free

D:\Driver\WMDIO APP v1.0.0.3\Driver\5.0.6.0>CD WMDIO Driver for Win7_64bit
D:\Driver\WMDIO APP v1.0.0.3\Driver\5.0.6.0\WMDIO Driver for Win7_64bit>DIR/W
Volume in drive D is RDVD
Volume Serial Number is 6834-E6A5

Directory of D:\Driver\WMDIO APP v1.0.0.3\Driver\5.0.6.0\WMDIO Driver for Win7_64bit
[.]
[.]          devcon.exe  install.bat  wmdio.cat   wmdio.inf   [x64]
          4 File(s)      91,614 bytes
          3 Dir(s)      60,736,315,392 bytes free

D:\Driver\WMDIO APP v1.0.0.3\Driver\5.0.6.0\WMDIO Driver for Win7_64bit>INSTALL
D:\Driver\WMDIO APP v1.0.0.3\Driver\5.0.6.0\WMDIO Driver for Win7_64bit>DEVCON.EXE INSTALL wmdio.inf "root\WMDIO"
Device node created. Install is complete when drivers are installed...
Updating drivers for root\WMDIO from D:\Driver\WMDIO APP v1.0.0.3\Driver\5.0.6.0\WMDIO Driver for Win7_64bit\wmdio.inf.
Drivers installed successfully.

D:\Driver\WMDIO APP v1.0.0.3\Driver\5.0.6.0\WMDIO Driver for Win7_64bit>pause
Press any key to continue . . .
```

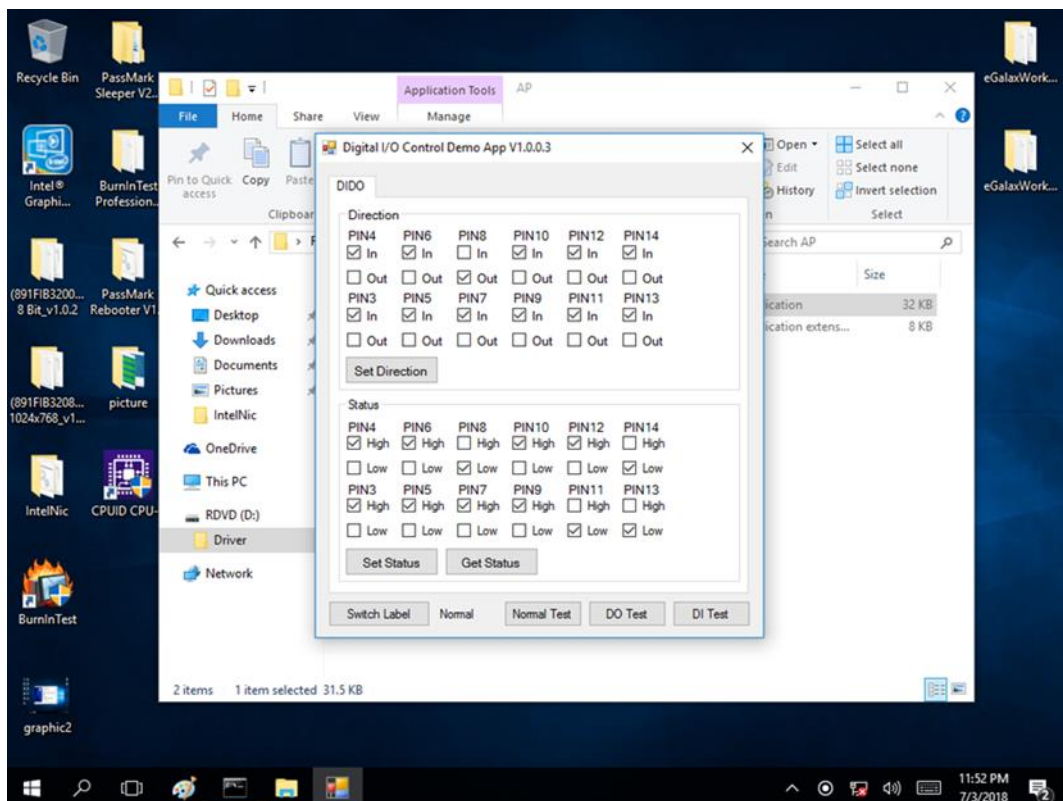
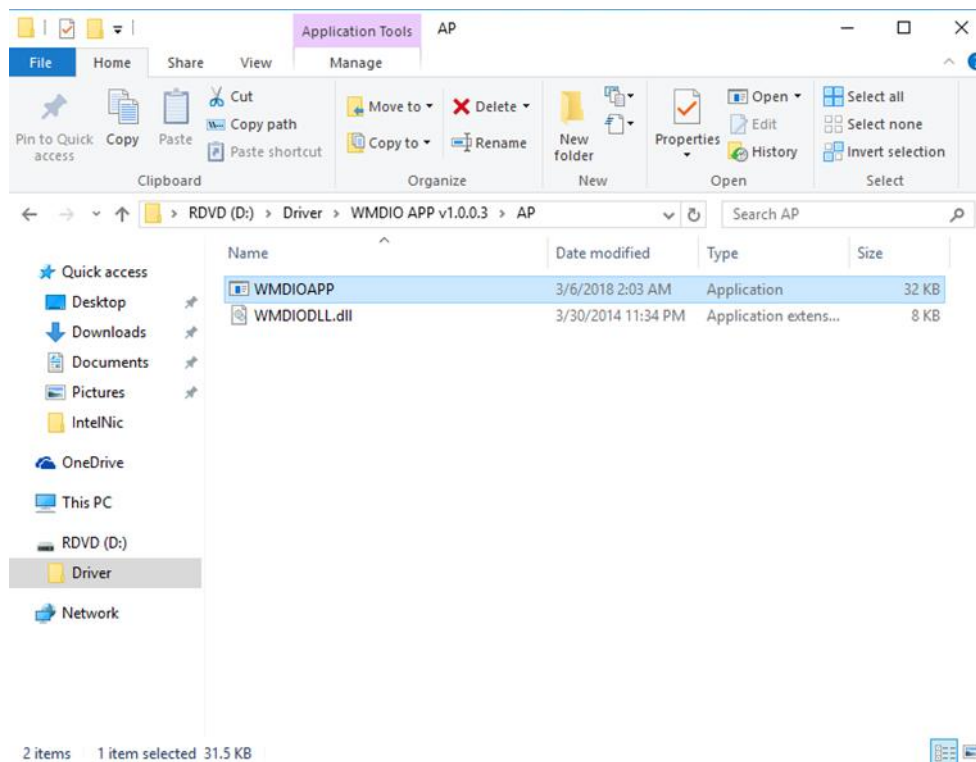
6. Open the Driver and select **Digital IO AP**.

## 4.10 Resistive Touch Driver for Windows 11 System

Follow the instructions below to install the touch driver.

### 1. Click setup

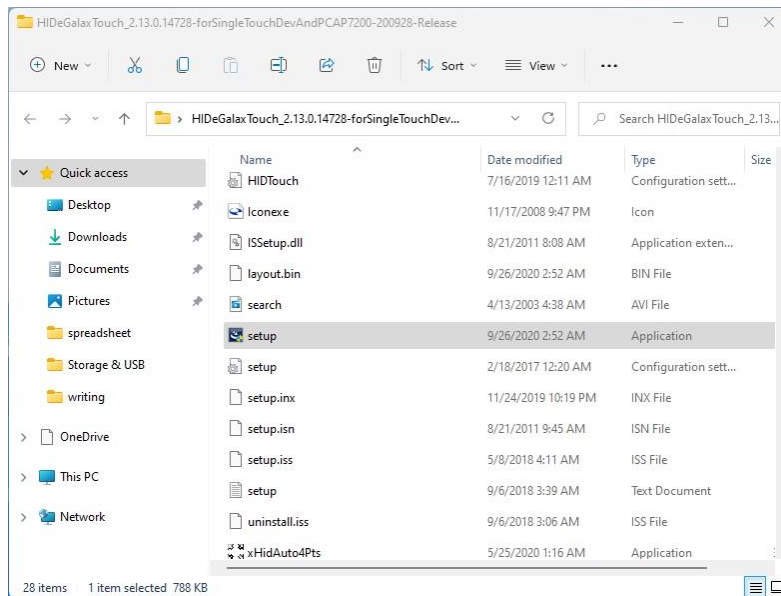

### 2. Click Next to continue

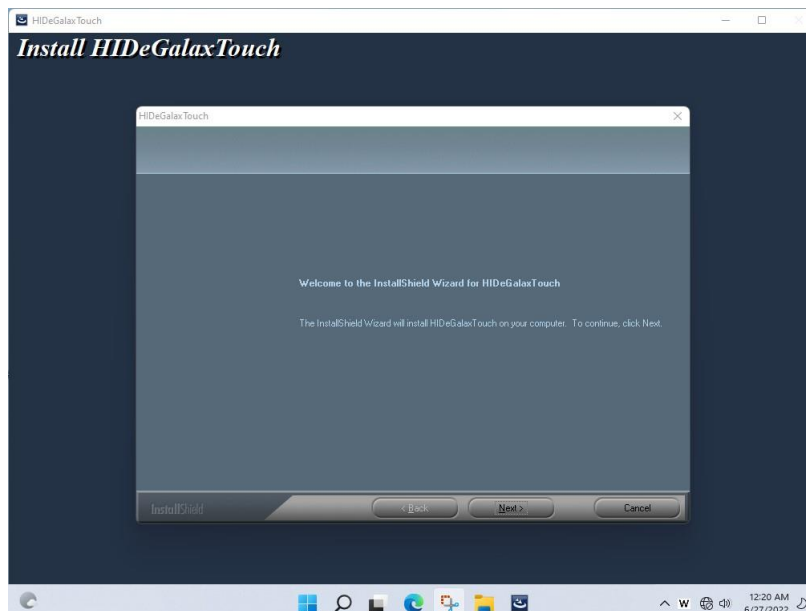

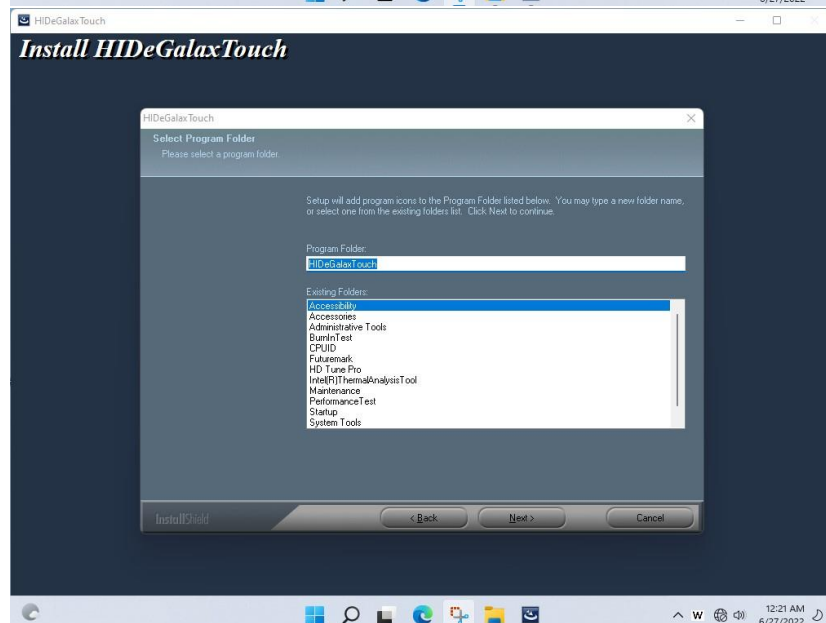
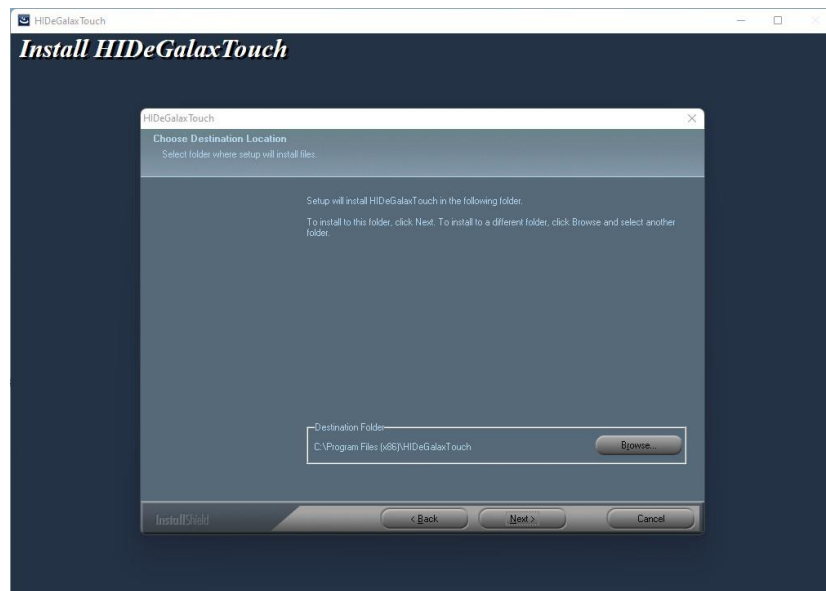
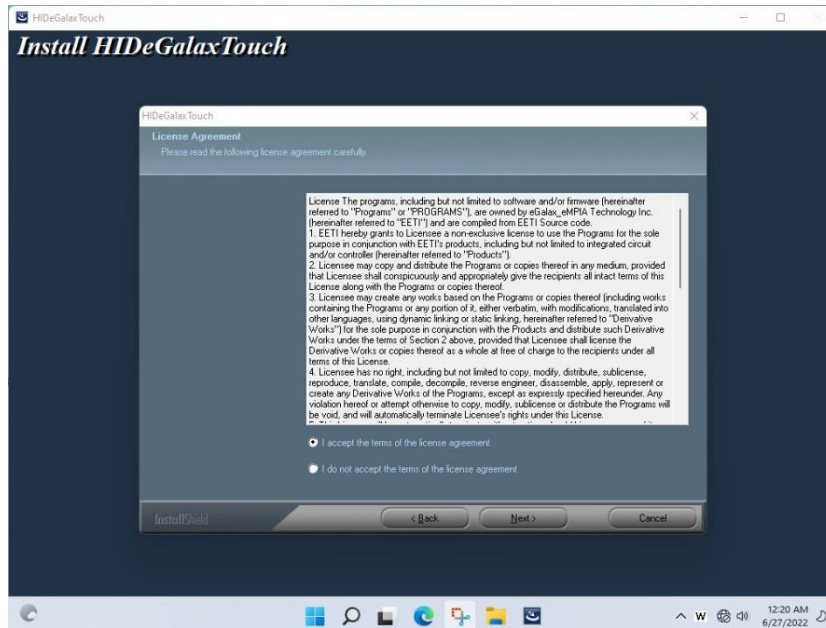

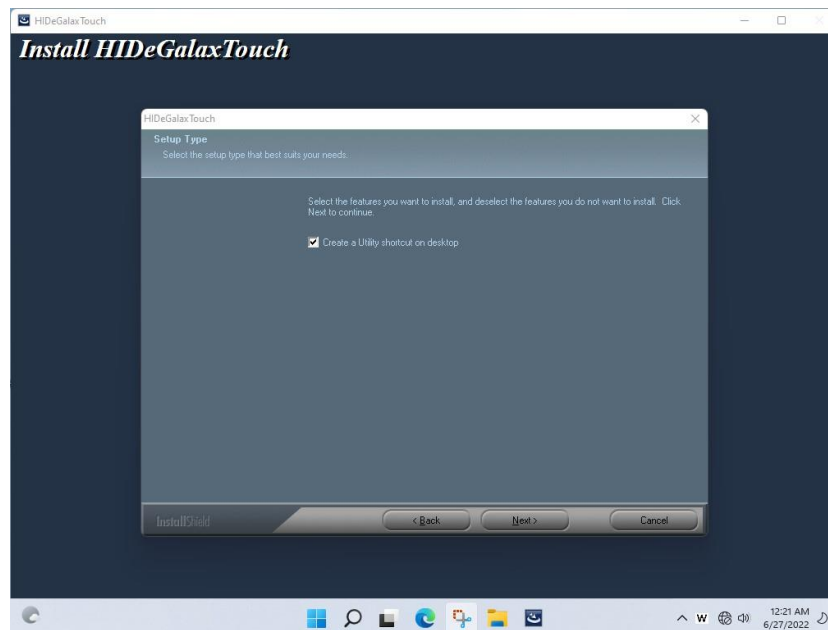

3. Click Yes to add this controller

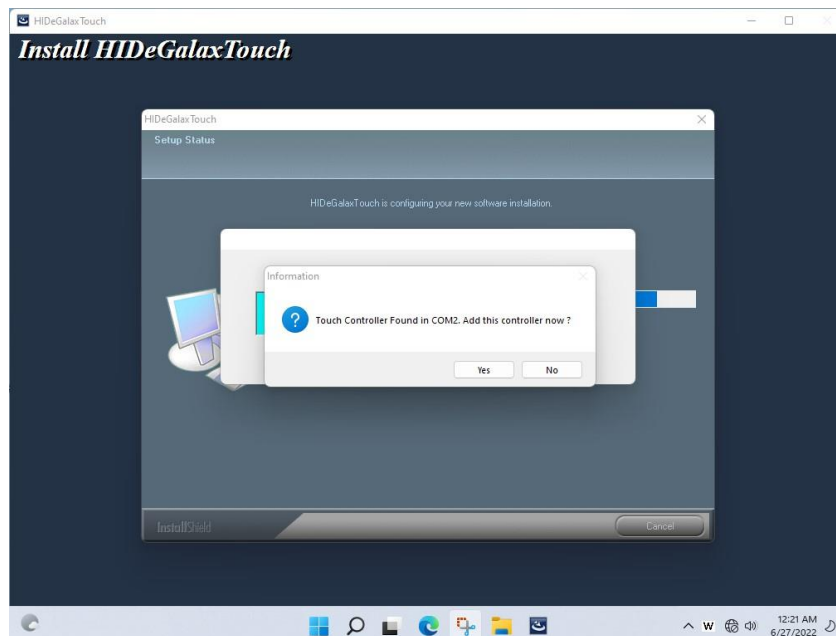

4. Restart the computer now and finish the setup.

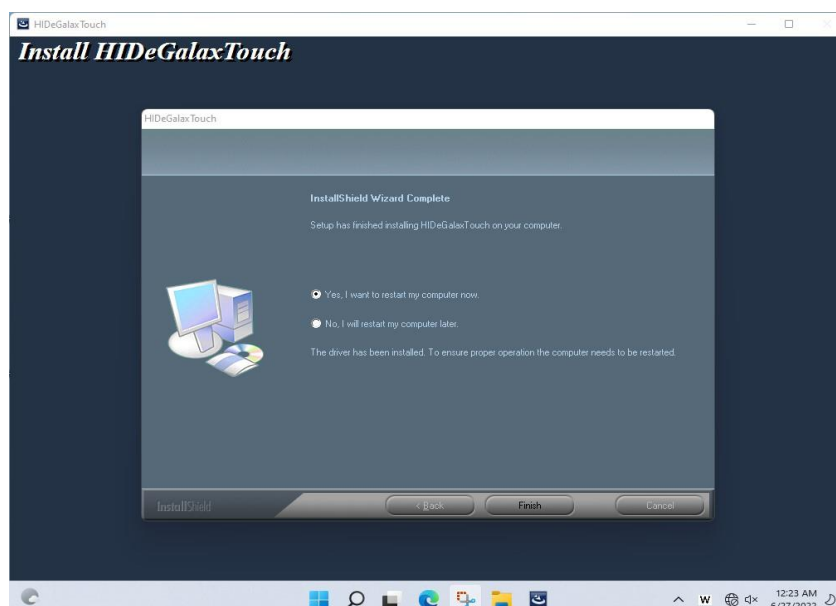

## Chapter 5: Technical Support

This chapter includes the directory for technical support. Free technical support is available from our engineers every business day. We are always ready to give advice on application requirements or specific information on the installation and operation of any of our products. If any problem occurs immediately contact us.

5.1 Drivers

5.2 Software Development Kit (SDK)

---

## 5.1 Drivers

The list of drivers available for IE32 3.5" SBC:

Item	Driver
1	Chipset Driver
2	Graphic Driver
3	ME Driver
4	SST Driver
5	Audio Driver
6	Ethernet Driver
7	Watchdog Driver/AP
8	Digital IO Driver/AP
9	Windows 11 Resistive Touch Driver

To find the Drivers, please download them from the download center or contact us.

## 5.2 Software Development Kit (SDK)

The list of SDK available for IE32 3.5" SBC:

Item	File Type	Description
1	SDK	Watchdog SDK
2	SDK	Digital IO SDK

To find the SDK, please download them from the download center or contact us.







Winmate Inc.  
9F, No.111-6, Shing-De Rd., San-Chung District,  
New Taipei City 24158, Taiwan, R.O.C  
[www.winmate.com](http://www.winmate.com)

