

R19IP3S-GCM1

19" Intel® Pentium® N4200 G-WIN GC-Series Front IP65 PCAP Panel PC



KEY FEATURES

- 19" 1280 x 1024 with P-CAP touchscreen
- Intel® Pentium® N4200 Apollo Lake Processor
- Fanless cooling system and ultra low power consumption
- Front IP65 for protection against water and dust
- A true flat, easy-to-clean front surface with edge-to-edge design

INTRODUCTION

Winmate G-WIN GC Series Panel PC Series offers advanced performance and flexibility, with sizes ranging from 7" to 24" and support for various operating systems, including Windows and Android. Designed with a fanless cooling system and ultra-low power consumption, these panel PCs feature a front IP65-rated edge-to-edge flat design for water and dust resistance and easy cleaning. With versatile I/O options, including USB, HDMI, and RS232/422/485, these robust devices are ideal for industrial automation, kiosks, and control systems, ensuring reliability in harsh environments.

SPECIFICATIONS

Display

Resolution	1280x1024	Size	19.0 inches
Contrast Ratio	1000:1	Panel Brightness	250.0 nits
View Angles	85,85,80,80	Active Area	376.32x301.06 mm
Touch / Glass	Projected Capacitive Multi Touch Screen		

System Specification

Processor	Intel Pentium N4200 1.1GHz (up to 2.5GHz)	Memory	4GB(Default) (Default) 8GB (Optional)
Storage	128GB SSD(Default) (Default) 256GB SSD (Optional) 512GB SSD (Optional) 1TB (Optional)	Ethernet controller	2 x Intel® Ethernet Controller
Security	TPM 2.0	Operating System	Windows 10 IoT Enterprise (64 bit) (Optional) Linux Ubuntu 20.04 (Optional)
WLAN	Support (Optional)	BT	Support (Optional)

Environment

Operating Humidity	10% to 90% RH, Non-Condensing	Operating Temperature	0°C to 50°C
Storage Temperature	-20°C to 60°C	Shock	MIL-STD-810G Method 516.6 Procedure I
Vibration	MIL-STD-810G Method 514.6 Procedure I	IP rating	Front IP65

Certification

Certification	CE, FCC
----------------------	---------

IO Ports

USB Port	2 x USB 3.0	Serial Port	1 x RS232(Default)/422/485
LAN	1 x RJ45-10/100/1000 Mbps, 1 x RJ45		
Mechanical			
Dimension	445 x 370 x 51 mm	Mounting	VESA mount (Default) Panel mount (Optional)
Enclosure	Metal Housing with Plastic Bezel	Cooling System	Fanless Design
Accessory			
Accessory	Quick Start Guide(Hardcopy) AC Adapter 12V/50W Power Cord 3 Pin Terminal Block to DC Jack		
Control			
Button	1 x Power Button 1 x Reset Button		
Power			
Power Rating	12V DC with Terminal Block		

DIMENSIONS UNIT:MM

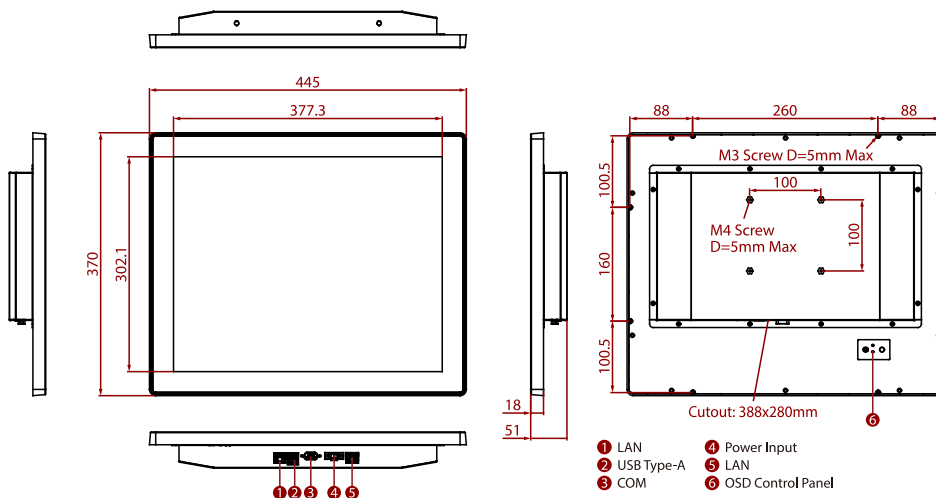

NOTE

1. This is a simplified drawing and some components are not marked in detail.
2. Please contact our sales representative if you need further product information.
3. All specifications are subject to change without prior notice.
4. The product shown in this datasheet is a standard model. For diagrams that contain customized or optional I/O, please contact the Winmate Sales Team for more information.