

7”/ 10.1”/ 14”/ 15”/ 15.6”

E-Series HMI

Intel® Celeron® Processor N6211
1.5M Cache, up to 3.00 GHz

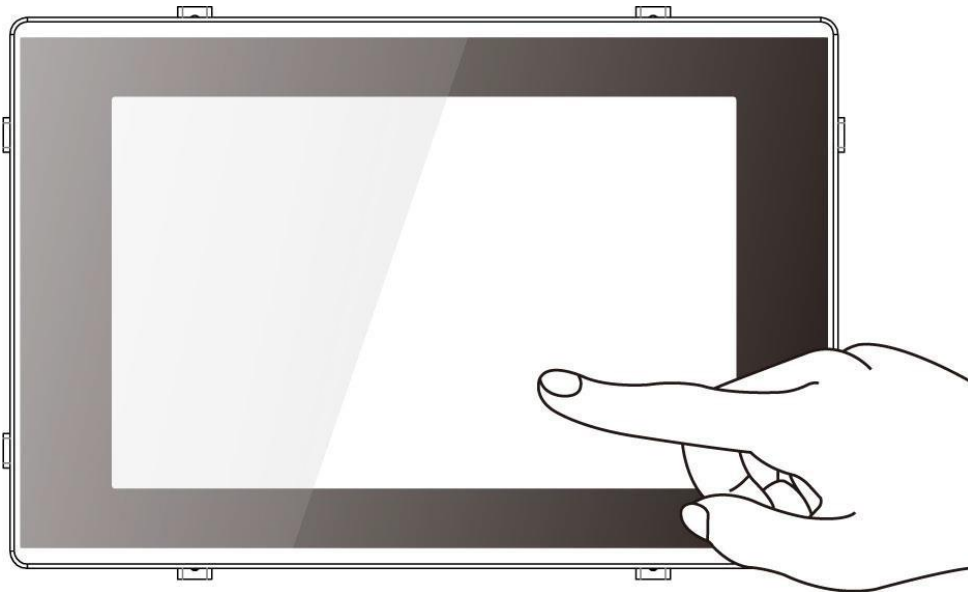

Model No.

W07IE3S-EHT1
W07IE3S-EHO1
W10IE3S-EHH2
W14IE3S-EHA1
R15IE3S-EHC3
W15IE3S-EHA4

Quick Start Guide

Contents

PREFACE	2
ABOUT THIS USER MANUAL	6
CHAPTER 1: INTRODUCTION	7
1.1 PRODUCT FEATURES	7
1.2 PACKAGE CONTENTS.....	8
1.3 DESCRIPTION OF PARTS.....	9
1.3.1 W07IE3S-EHT1 ; E-SERIES HMI 7"	9
1.3.2 W07IE3S-EHO1 ; E-SERIES HMI 7"	9
1.3.3 W10IE3S-EHH2 ; E-SERIES HMI 10.1".....	10
1.3.4 W14IE3S-EHA1 ; E-SERIES HMI 14".....	10
1.3.5 R15IE3S-EHC3 ; E-SERIES HMI 15"	11
1.3.6 W15IE3S-EHA4 ; E-SERIES HMI 15.6".....	11
CHAPTER 2: GETTING STARTED	12
2.1 POWERING ON.....	12
2.1.1 AC ADAPTER COMPONENTS	12
2.1.2 POWER CONSIDERATIONS	13
2.1.3 CONNECTING THE POWER	13
2.2 TURNING ON AND OFF THE HMI DEVICE.....	13
CHAPTER 3: MOUNTING	14
3.1 CABLE MOUNTING CONSIDERATIONS.....	14
3.2 SAFETY PRECAUTIONS	14
3.3 MOUNTING GUIDE	15
3.3.1 VESA MOUNT	15
3.3.2 PANEL MOUNT	16
APPENDIX A: PRODUCT SPECIFICATIONS	17

Preface

Copyright Notice

No part of this document may be reproduced, copied, translated, or transmitted in any form or by any means, electronic or mechanical, for any purpose, without the prior written permission of the original manufacturer.

Trademark Acknowledgement

Brand and product names are trademarks or registered trademarks of their respective owners.

Disclaimer

We reserve the right to make changes, without notice, to any product, including circuits and/or software described or contained in this manual in order to improve design and/or performance. We assume no responsibility or liability for the use of the described product(s) conveys no license or title under any patent, copyright, or masks work rights to these products, and make no representations or warranties that these products are free from patent, copyright, or mask work right infringement, unless otherwise specified. Applications that are described in this manual are for illustration purposes only. We make no representation or guarantee that such application will be suitable for the specified use without further testing or modification.

Warranty

Our warranty guarantees that each of its products will be free from material and workmanship defects for a period of one year from the invoice date. If the customer discovers a defect, we will, at his/her option, repair or replace the defective product at no charge to the customer, provide it is returned during the warranty period of one year, with transportation charges prepaid. The returned product must be properly packaged in its original packaging to obtain warranty service. If the serial number and the product shipping data differ by over 30 days, the in-warranty service will be made according to the shipping date. In the serial numbers the third and fourth two digits give the year of manufacture, and the fifth digit means the month (e. g., with A for October, B for November and C for December).

For example, the serial number 1W16Axxxxxxx means October of year 2016.

Customer Service

We provide a service guide for any problem by the following steps: First, visit the website of our distributor to find the update information about the product. Second, contact with your distributor, sales representative, or our customer service center for technical support if you need additional assistance.

You may need the following information ready before you call:

- Product serial number
- Software (OS, version, application software, etc.)
- Description of complete problem
- The exact wording of any error messages

In addition, free technical support is available from our engineers every business day. We are always ready to give advice on application requirements or specific information on the installation and operation of any of our products.

Advisory Conventions

Four types of advisories are used throughout the user manual to provide helpful information or to alert you to the potential for hardware damage or personal injury. These are Notes, Important, Cautions, and Warnings. The following is an example of each type of advisory.



NOTE:

A note is used to emphasize helpful information



IMPORTANT:

An important note indicates information that is important for you to know.



CAUTION/ ATTENTION

A Caution alert indicates potential damage to hardware and explains how to avoid the potential problem.

Une alerte d'attention indique un dommage possible à l'équipement et explique comment éviter le problème potentiel.



WARNING!/ AVERTISSEMENT!

An Electrical Shock Warning indicates the potential harm from electrical hazards and how to avoid the potential problem.

Un Avertissement de Choc Électrique indique le potentiel de chocs sur des emplacements électriques et comment éviter ces problèmes.



ALTERNATING CURRENT / MISE À LE TERRE!

The Protective Conductor Terminal (Earth Ground) symbol indicates the potential risk of serious electrical shock due to improper grounding.

Le symbole de Mise à Terre indique le risqué potentiel de choc électrique grave à la terre incorrecte.

Safety Information

WARNING! / AVERTISSEMENT!

Always completely disconnect the power cord from your chassis whenever you work with the hardware. Do not make connections while the power is on. Sensitive electronic components can be damaged by sudden power surges. Only experienced electronics personnel should open the PC chassis.



Toujours débrancher le cordon d'alimentation du chassis lorsque vous travaillez sur celui-ci. Ne pas brancher de connexions lorsque l'alimentation est présente. Des composantes électroniques sensibles peuvent être endommagées par des sauts d'alimentation. Seulement du personnel expérimenté devrait ouvrir ces chassis.

CAUTION/ATTENTION

Always ground yourself to remove any static charge before touching the CPU card. Modern electronic devices are very sensitive to static electric charges. As a safety precaution, use a grounding wrist strap at all times. Place all electronic components in a static-dissipative surface or static-shielded bag when they are not in the chassis.



Toujours vérifier votre mise à la terre afin d'éliminer toute charge statique avant de toucher la carte CPU. Les équipements électroniques modernes sont très sensibles aux décharges d'électricité statique. Toujours utiliser un bracelet de mise à la terre comme précaution. Placer toutes les composantes électroniques sur une surface conçue pour dissiper les charge, ou dans un sac anti-statique lorsqu'elles ne sont pas dans le chassis.

Safety Precautions

For your safety carefully read all the safety instructions before using the device. Keep this user manual for future reference.

- Always disconnect this equipment from any AC outlet before cleaning. Do not use liquid or spray detergents for cleaning. Use a damp cloth.
- For pluggable equipment, the power outlet must be installed near the equipment and must be easily accessible.
- Keep this equipment away from humidity.
- Put this equipment on a reliable surface during installation. Dropping it or letting it fall could cause damage.
- The openings on the enclosure are for air convection and to protect the equipment from overheating.

**CAUTION/ATTENTION**

Do not cover the openings!

Ne pas couvrir les ouvertures!

- Before connecting the equipment to the power outlet make sure the voltage of the power source is correct.
- Position the power cord so that people cannot step on it. Do not place anything over the power cord.
- If the equipment is not used for a long time, disconnect it from the power source to avoid damage by transient over-voltage.
- Never pour any liquid into an opening. This could cause fire or electrical shock.
- Never open the equipment. For safety reasons, only qualified service personnel should open the equipment.
- All cautions and warnings on the equipment should be noted.

***Let service personnel to check the equipment in case any of the following problems appear:**

- The power cord or plug is damaged.
- Liquid has penetrated into the equipment.
- The equipment has been exposed to moisture.
- The equipment does not work well or you cannot get it to work according to the user manual.
- The equipment has been dropped and damaged.
- The equipment has obvious signs of breakage.
- Do not leave this equipment in an uncontrolled environment where the storage temperature is below -20°C (-4°F) or above 60°C (140°F). It may damage the equipment.

**CAUTION/ATTENTION**

Use the recommended mounting apparatus to avoid risk of injury.
Utiliser l'appareil de fixation recommandé pour éliminer le risque de blessure.

**WARNING! / AVERTISSEMENT!**

Only use the connection cords that come with the product. When in doubt, please contact the manufacturer.

Utiliser seulement les cordons d'alimentation fournis avec le produit. Si vous doutez de leur provenance, contactez le fabricant.

**WARNING! / AVERTISSEMENT!**

Always ground yourself against electrostatic damage to the device.

Toujours vérifier votre mise à la terre afin que l'équipement ne se décharge pas sur vous.

- Cover workstations with approved anti-static material. Use a wrist strap connected to a work surface and properly grounded tools and equipment.
- Use anti-static mats, heel straps, or air ionizer for added protection.
- Avoid contact with pins, leads, or circuitry.
- Turn off power and input signals before inserting and removing connectors or test equipment.
- Keep the work area free of non-conductive materials, such as ordinary plastic assembly aids and Styrofoam.
- Use filed service tools, such as cutters, screwdrivers, and vacuum cleaners that are conductive.
- Always put drivers and PCB's component side on anti-static foam.

Important Information

Federal Communications Commission Radio Frequency Interface Statement



This device complies with part 15 FCC rules.

Operation is subject to the following two conditions:

- This device may not cause harmful interference.
- This device must accept any interference received including interference that may cause undesired operation.

This equipment has been tested and found to comply with the limits for a class "B" digital device, pursuant to part 15 of the FCC rules. These limits are designed to provide reasonable protection against harmful interference when the equipment is operated in a commercial environment. This equipment generates, uses, and can radiate radio frequency energy and, if not installed and used in accordance with the instruction manual, may cause harmful interference to radio communications. Operation of this equipment in a residential area is likely to cause harmful interference in which case the user will be required to correct the interference at his own expense.

EC Declaration of Conformity



This equipment is in conformity with the requirement of the following EU legislations and harmonized standards. Product also complies with the Council directions.

Electromagnetic Compatibility Directive (2014/30/EU)

- EN55024: 2010 EN 55022: 2010 Class B
 - IEC61000-4-2: 2009
 - IEC61000-4-3: 2006+A1: 2007+A2: 2010
 - IEC61000-4-4: 2012
 - IEC61000-4-5: 2014
 - IEC61000-4-6: 2013
 - IEC61000-4-8: 2010
 - IEC61000-4-11: 2004
- EN55022: 2010/AC:2011
- EN61000-3-2:2014
- EN61000-3-3:2013

Low Voltage Directive (2014/35/EU)

- EN 60950-1:2006/A11:2009/A1:2010/A12:2011/ A2:2013

About This User Manual

This User Manual provides information about using the Winmate® E-Series HMI.

This User Manual applies to the E-Series HMI – W07IE3S-EHT1, W07IE3S-EHO1, W10IE3S-EHH2, W14IE3S-EHA1, R15IE3S-EHC3, W15IE3S-EHA4. The documentation set for the E-Series HMI with Intel® Celeron® Processor N6211 1.5M Cache, up to 3.00 GHz provides information for specific user needs, and includes:

- **E-Series HMI User Manual** – contains detailed description on how to use the HMI device, its components and features.
- **E-Series HMI Quick Start Guide** - describes how to get the HMI up and running.



NOTE:

Some pictures in this guide are samples and can differ from actual product.

Chapter 1: Introduction

Congratulations on purchasing the Winmate® E-Series HMI. The E-Series HMI runs on Windows 10 IOT Enterprise 64bit, Windows 11 IOT Enterprise 64bit and Linux Kernel V5.18, or above versions that allow installing the latest applications. Thereby wide customization possibilities are available to satisfy the needs of industrial automation.

With mounting clips for panel mounting there is no need to drill holes in a fixture. This saves you the time for mounting.

1.1 Product Features

The Winmate® E-Series HMI features:

- Projected Capacitive Multi Touch (PCAP)
- Intel® Celeron® Processor N6211 1.5M Cache, up to 3.00 GHz
- Fanless cooling system and ultra-low power consumption
- Front IP65 Water and Dust Proof

1.2 Package Contents

Carefully remove the box and unpack your device. Please check if all the items listed below are inside your package. If any of these items are missing or damaged contact us immediately.

Standard factory shipment list:

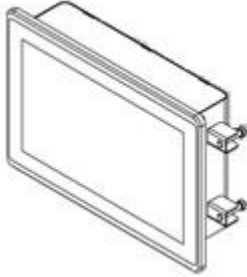

E-Series HMI Device

Varies by product specifications



Quick Start Guide (Hardcopy)

Part No. 91521110115R

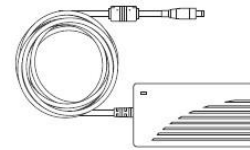

AC Adapter (12V/ 50W)

Part No. 922D050W12VA

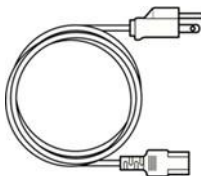

Power Cord

Varies by country

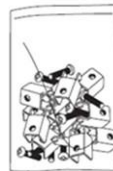

Mounting Clips and Screws

7" HMI – 7 pcs
10.1" HMI – 7 pcs
14" HMI – 10 pcs
15" HMI – 12 pcs
15.6" HMI – 10 pcs

Part No. 82111E240400

**Package content may vary based on your order.*

1.3 Description of Parts

This section describes appearance, connectors' layout and mechanical dimensions of E-Series HMI. Notice that this is a simplified drawing and some components are not marked in detail. Please contact our sales representative if you need further product information.

1.3.1 W07IE3S-EHT1 ; E-Series HMI 7"

Unit: mm

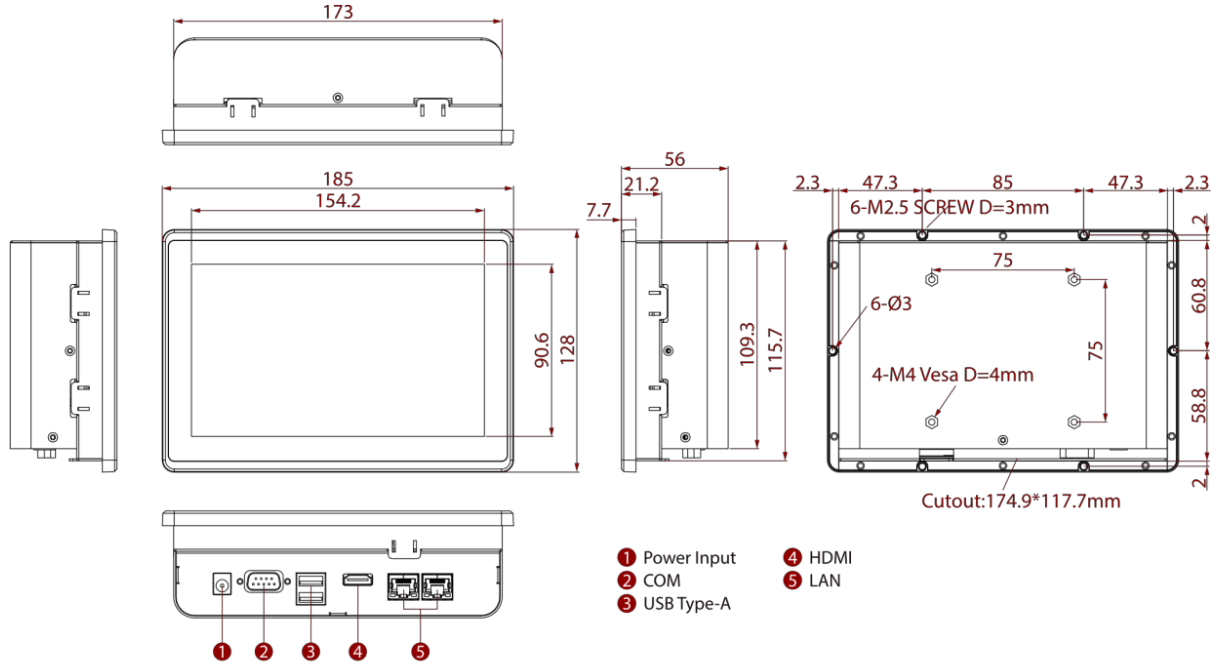

1.3.2 W07IE3S-EH01 ; E-Series HMI 7"

Unit: mm

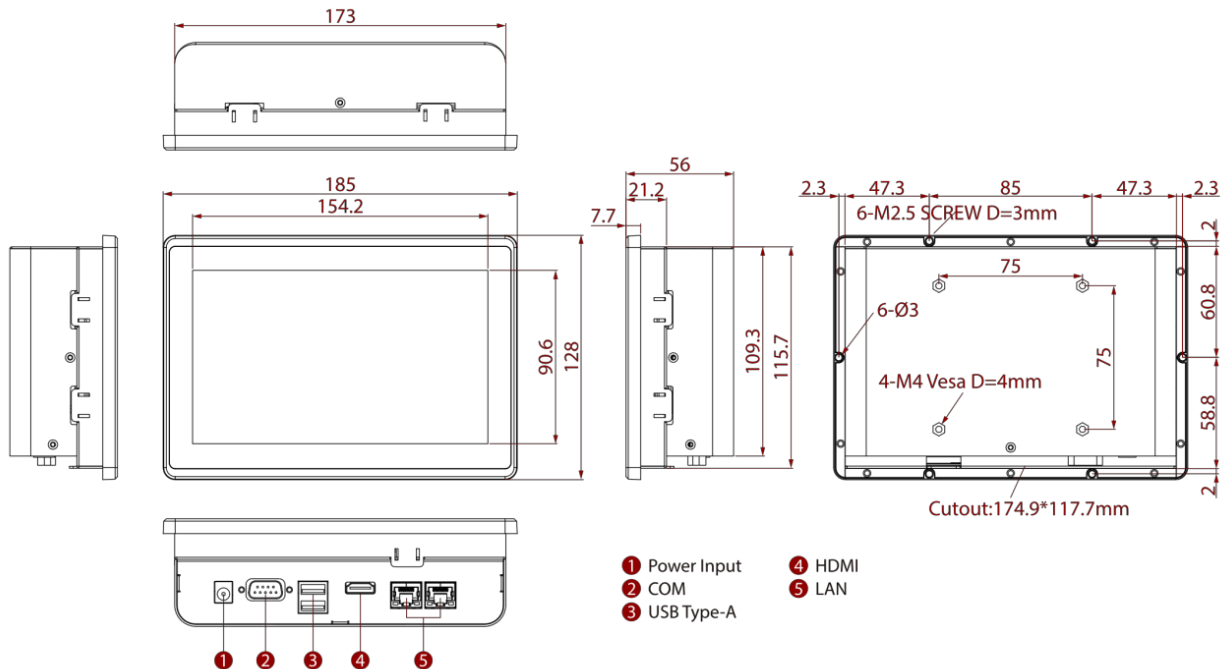

1.3.3 W10IE3S-EHH2 ; E-Series HMI 10.1"

Unit: mm

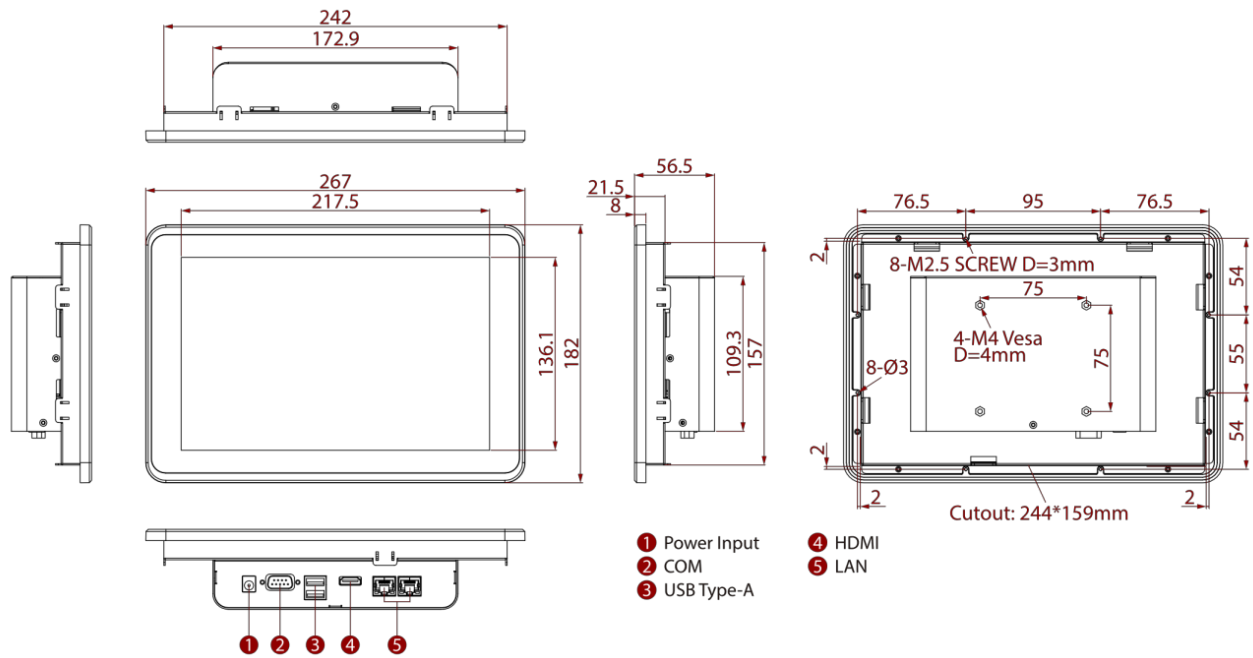
**1.3.4 W14IE3S-EHA1 ; E-Series HMI 14"**

Unit: mm

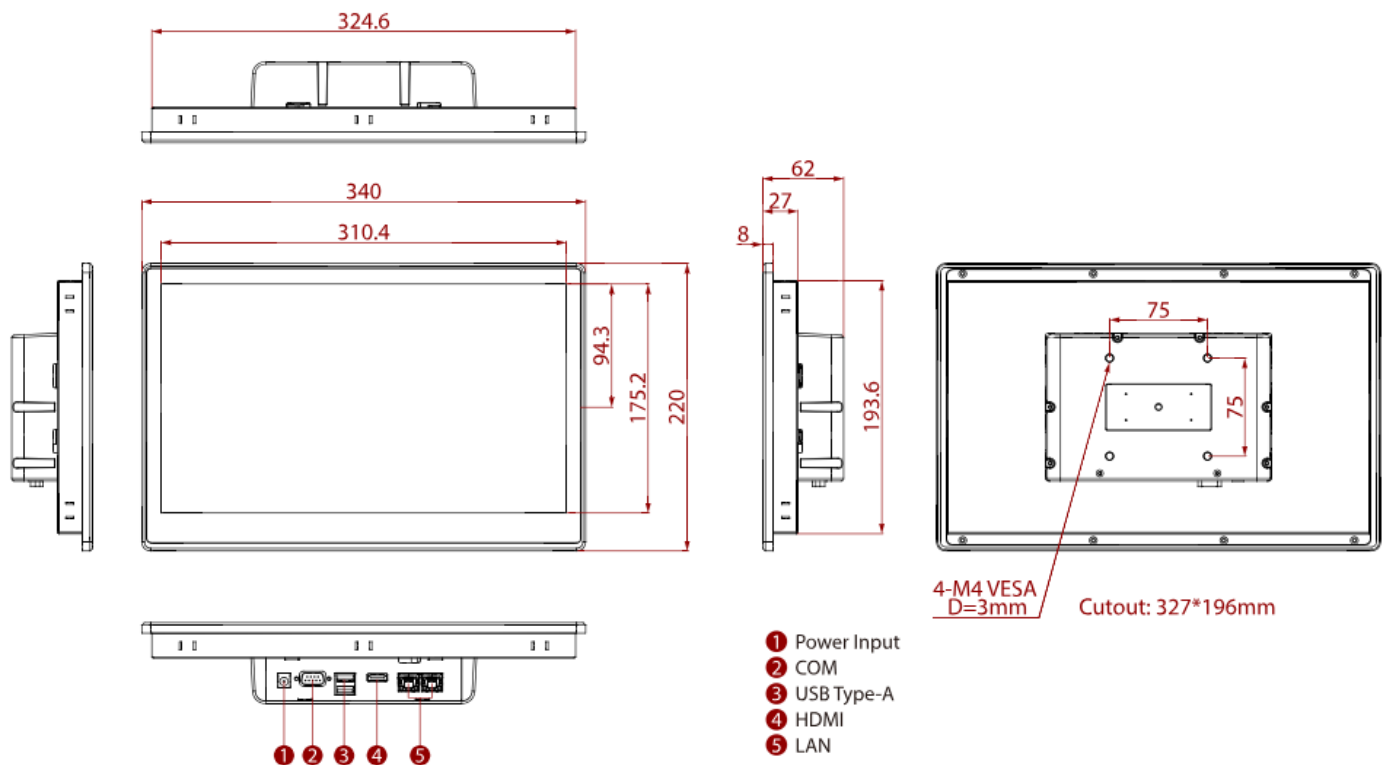

1.3.5 R15IE3S-EHC3 : E-Series HMI 15"

Unit: mm

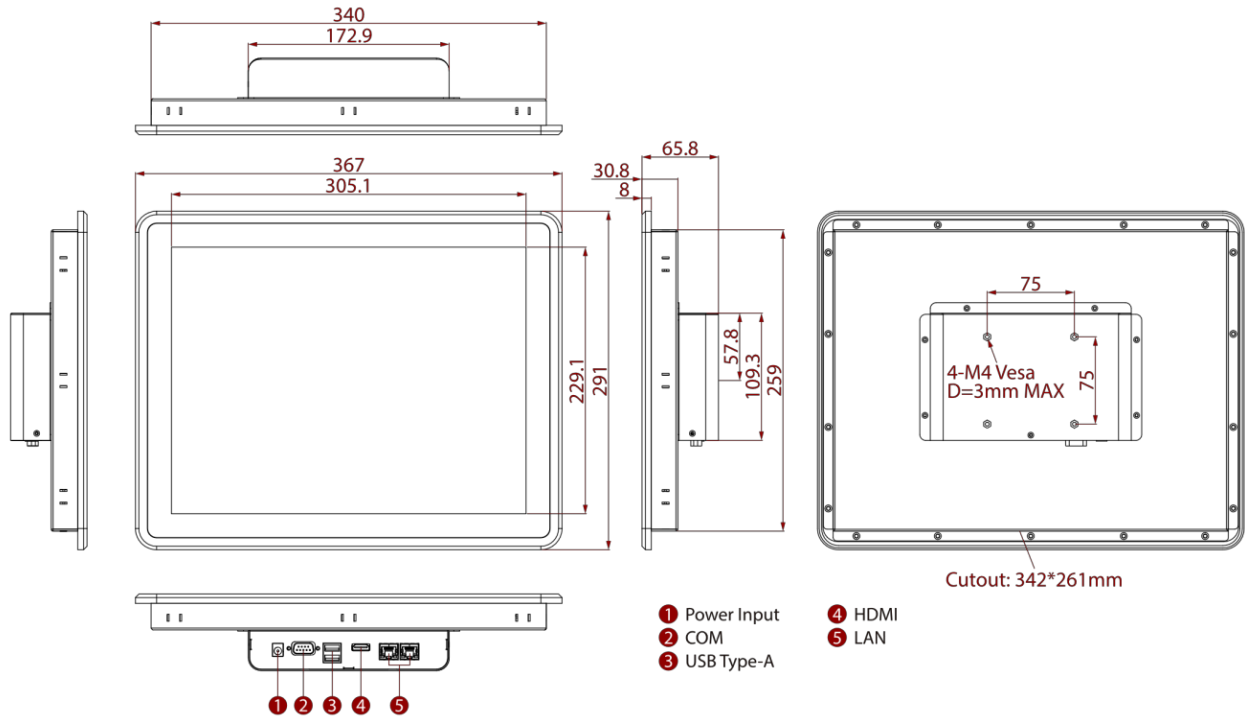

1.3.6 W15IE3S-EHA4 : E-Series HMI 15.6"

Unit: mm

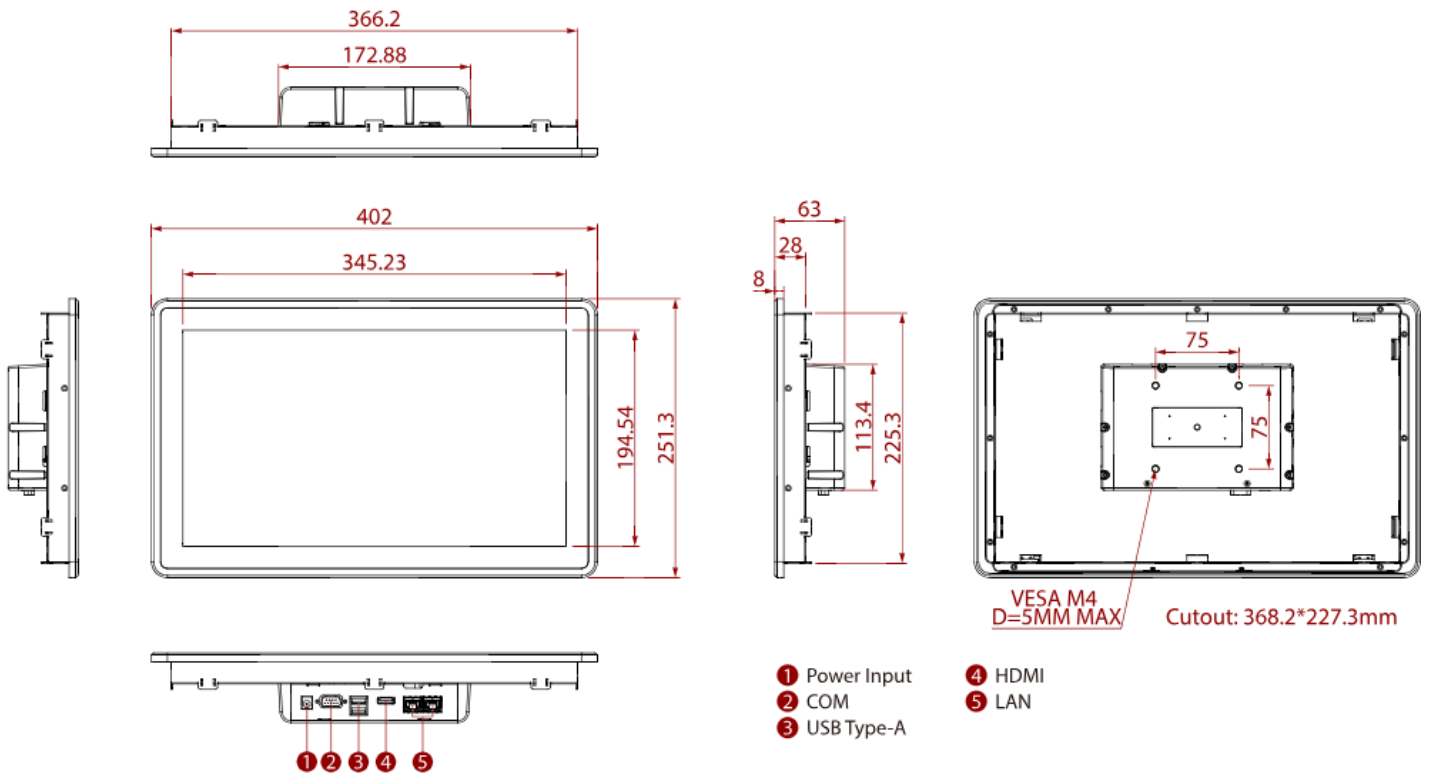

Chapter 2: Getting Started

This chapter provides information on how to connect the HMI device to the source of power, connector pinouts and the guideline to turn on/off the HMI device.

2.1 Powering On

2.1.1 AC Adapter Components

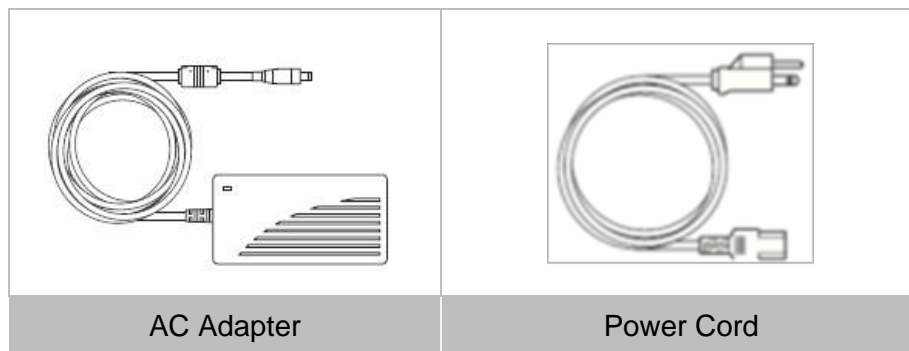

Safety Precautions:

- Do not use the adapter in a high moisture environment
- Never touch the adapter with wet hands or foot
- Allow adequate ventilation around adapter while using
- Do not cover the adapter with paper or other objects that will reduce cooling
- Do not use the adapter while it is inside a carrying case
- Do not use the adapter if the cord is damaged
- There are NO serviceable parts inside
- Replace the unit if it is damaged or exposed to excess moisture

While using the AC Adapter always:

- Plug-in the power cord to easily accessible AC outlet
- Plug-in the AC adapter to a grounded outlet



ALTERNATING CURRENT / MISE À LE TERRE!

This product must be grounded. Use only a grounded AC outlet. Install the additional PE ground wire if the local installation regulations require it.

*If you do not use a grounded outlet while using the device, you may notice an electrical tingling sensation when the palms of your hands touch the device.

Ce produit doit être mis à la terre. Utiliser seulement un cordon d'alimentation avec mise à la terre. Si les règlements locaux le requiert, installer des câbles de mise à la terre supplémentaires.

*Si vous n'utilisez pas une prise d'alimentation avec mise à la terre, vous pourriez remarquer une sensation de picotement électrique quand la paume de vos mains touche à l'appareil.

2.1.2 Power Considerations

The HMI device operates on external DC power. Use the AC adapter included in the package.



CAUTION/ATTENTION

Use only the AC adapter included in your package (Rating: Output 12 V/ 4.16A). Using other AC adapters may damage the device.

Utiliser seulement le convertisseur AC inclu avec votre appareil (Puissance: Sortie 12 V/ 4.16A). Utiliser d'autres convertisseurs pourraient endommager l'appareil.

2.1.3 Connecting the Power

Installation Instruction:

1. Connect the DC Plug of AC Adapter to the HMI connector.
2. Connect the AC adapter to the power cord.
3. Plug in the power cord to a working AC wall outlet. The device will boot automatically.

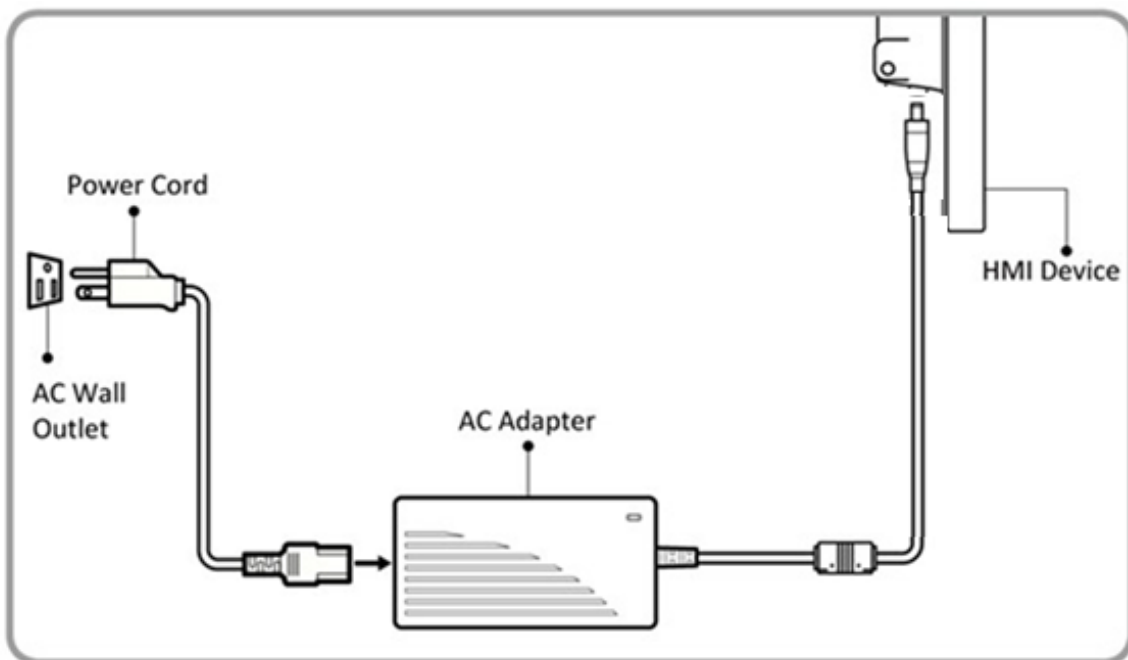

Note:

Power cords vary in appearance by region and country.

2.2 Turning On and Off the HMI Device

This section describes how to turn on and off the HMI device. To **turn on** the HMI device:

1. Connect the HMI device to the source of power.
2. The unit is configured to **Power ON** when is connected to the power source.

E-series HMI support Windows 10 IoT Enterprise 64bit & Windows 11 IOT Enterprise 64bit operating system.



IMPORTANT

The device is shipped with the OS System according to your order. Contact us if you have any questions regarding OS settings.

Chapter 3: Mounting

This chapter provides mounting guide for all available mounting options. Pay attention to cautions and warning to avoid any damages.

3.1 Cable Mounting Considerations

For a nice look and safe installation, make sure cables are neatly hidden behind the HMI device. Refer to [Chapter 2.1](#) for the cable installation instruction.



CAUTION/ ATTENTION

Observe all local installation requirements for connection cable type and protection level.

Suivre tous les règlements locaux d'installations, de câblage et niveaux de protection.



CAUTION/ ATTENTION

Turn off the device and disconnect other peripherals before installation. Éteindre l'appareil et débrancher tous les périphériques avant l'installation.



ALTERNATING CURRENT / MISE À LE TERRE!

To prevent electrical shock, the Safety Ground location on the rear must be bonded to the local earth ground through a minimum 12 AWG wire as short as possible

Pour éviter les chocs électriques, l'emplacement de la prise terre à l'arrière doit être lié à terre locale, à travers un 12 AWG minimum et aussi court que possible.

3.2 Safety Precautions

Observe the following common safety precautions before installing any electronic device:

- Use separate, non-intersecting paths to route power and networking wires. If power wiring and device wiring paths must be crossed make sure the wires are perpendicular at the intersection point.
- Keep the wires separated according to the interface. Wires that share similar electrical characteristics must be bundled together.
- Do not bundle input wiring with output wiring. Keep them separate.

When necessary, it is strongly advised that you label wiring to all devices in the system.

3.3 Mounting Guide

E-series HMI devices come with different mounting options suitable for most of the industrial and commercial applications. The main mounting approach is rear mount - very user-friendly in terms of installation. Refer to sub-sections below for more details.



CAUTION/ ATTENTION

Follow mounting instructions and use recommended mounting hardware to avoid the risk of injury.

Suivez les instructions de montage et d'utilisation recommandé le matériel de montage pour éviter le risque de blessure.

3.3.1 VESA Mount

VESA Mount is a widely used mounting solution suitable for all kinds of industrial applications. Notice that VESA Mount solution applies only to 7",10.1",14" ,15" and 15.6" E-Series HMI.

Model Name	Dimensions	Screw Hole Diameter
W07IE3S-EHT1	75 x 75 mm	VESA M4 x 5 mm
W07IE3S-EHO1		
W10IE3S-EHH2		
W14IE3S-EHA1		
R15IE3S-EHC3		
W15IE3S-EHA4		

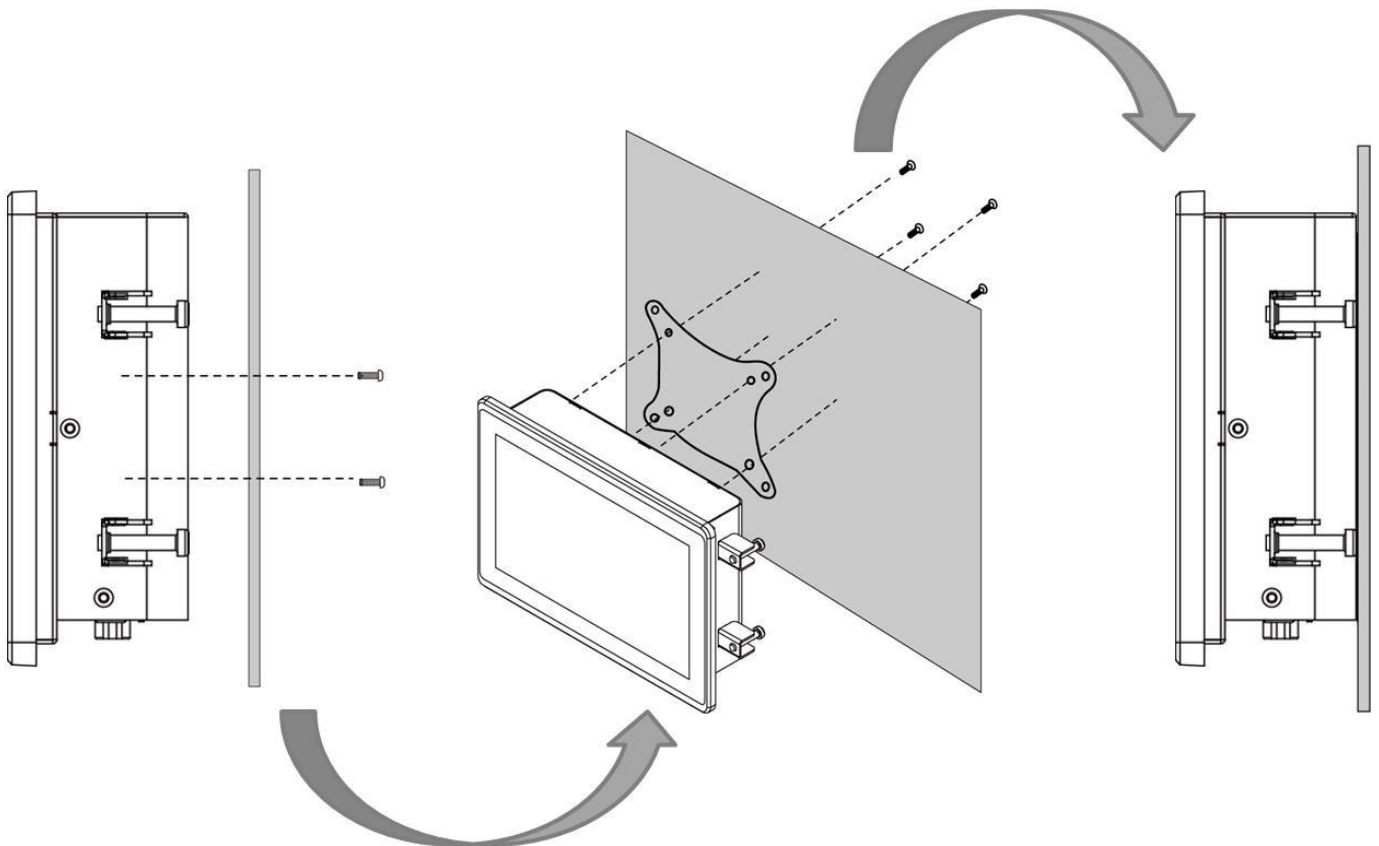

**with customer's bracket*

Mounting Steps:

1. Screw VESA bracket to the fixture (ex. wall) with four M4 x 5 mm VESA screws.
2. Place the device on VESA bracket

3.3.2 Panel Mount

Panel Mount solution is suitable for many applications where HMI should be embedded in the machine. With this mounting solution flat surface leave no bezel in the front. In addition to elegant design, rear mount solution is making the HMI unit easy to clean and maintain. The HMI device is secured to the fixture from the rear by using the mounting brackets included in the package.

Size	7"	10.1"	14"	15"	15.6"
Cutout dimension (W x D in mm)	177 x 118	244 x 159	318.6 x 198.6	336 x 266	368.2 x 227.3
Mounting Clips and Screws	7 pcs	7 pcs	10 pcs	12 pcs	10 pcs

Mounting Steps:

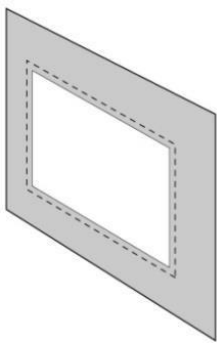
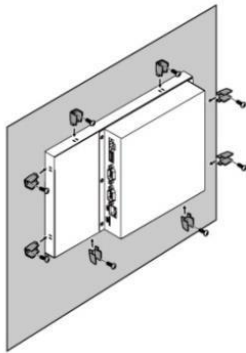
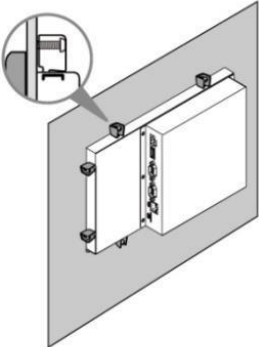
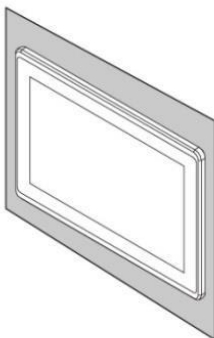
<p>1</p> 	<p>Prepare a cutout on a fixture according to the cutout dimensions.</p>
<p>2</p> 	<p>Select the mounting holes according to the wall thickness of the fixture and secure the mounting clips onto four sides of the HMI device.</p>
<p>3</p> 	<p>Secure the HMI to the fixture by screws.</p>
<p>4</p> 	<p>Connect power and other peripherals to the HMI unit.</p>

Appendix A: Product Specifications

	Model Name		
	W07IE3S-EHT1	W07IE3S-EHO1	W10IE3S-EHH2
Display			
Size/ Type	7"		10.1"
Resolution	1024x600		1280 x 800
Brightness	320 nits	1000 nits	350 nits 1000 nits (Optional)
Contrast Ratio	1000:1	700:1	800:1
Viewing Angle	75,75,75,70		85,85,85,85
Touch	Projected Capacitive Multi Touch Screen		
Mechanical Specifications			
Dimensions (mm)	185 x 128 x 56		267 x 182 x 56.5
Mounting	Panel mount VESA Mount		
Cooling	Fanless design		
Enclosure	Metal Front Cover and Plastic Rear Cover		
Cut out (mm)	174.9 x 117.7mm		244 x 159 mm
System Specifications			
Processor	Intel® Celeron® Processor N6211(1.5M Cache, up to 3.00 GHz)		
System Memory	1 x SO-DIMM, DDR4-3200 MHz, 4GB (up to 16GB, Optional)		
Operating System	Windows 11 IoT Enterprise 64-bit (Optional) Windows 11 Professional 64-bit (Optional) Windows 10 IoT Enterprise 64-bit (Optional) Linux Ubuntu 22.04 or above version (Optional)		
Storage	1 x M.2 Key B SSD 128GB (up to 1TB, Optional)		
WLAN	Optional		
Bluetooth	Optional		
Input / Output			
USB Ports	2 x USB 3.2 Gen 1x1 (Type A),		
COM Port	1 x RS232/422/485 (Default RS232)		
LAN	2 x Giga LAN RJ45		
Expansion Port	1 x M.2 Key E		
Video	1 x HDMI 2.0 (Optional)		
Power Specifications			
Power Input	12V DC / 9~ 36V (Optional)		
Adapter	12V 50W		
Environment Considerations			
Operating Temp.	0 ~ 50 °C		
Operating Humidity	10 ~ 90% (non-condensing)		
Storage Temperature	-20 ~ 60 °C		
IP rating	Front IP65		
Shock/ Vibration	MIL-STD-810G (Method 514.6)		
Certification			
Certification	CE, FCC		

	Model Name		
	W14E3S-EHA1	R15IE3S-EHC3	W15IE3S-EHA4
Display			
Size/ Type	14"	15"	15.6"
Resolution	1920 x 1080	1024 x 768	1280 x 800
Brightness	600 nits	300 nits	400 nits
Contrast Ratio	1200:1	2000:1	800:1
Viewing Angle	89,89,89,89	88,88,88,88	85,85,85,85
Touch	Projected Capacitive Multi Touch Screen		
Mechanical Specifications			
Dimensions (mm)	340 x 220 x 62	388 x 260 x 62.5	402 x 251 x 63
Mounting	Panel mount VESA Mount		
Cooling	Fanless design		
Enclosure	Metal Front Cover and Plastic Rear Cover		
Cut out (mm)	327 x 196	371 x 223	368.2 x 227.3
System Specifications			
Processor	Intel® Celeron® Processor N6211(1.5M Cache, up to 3.00 GHz)		
System Memory	1 x SO•DIMM, DDR4-3200 MHz, 4GB (up to 16GB, Optional)		
Operating System	Windows 11 IoT Enterprise 64-bit (Optional) Windows 11 Professional 64-bit (Optional) Windows 10 IoT Enterprise 64-bit (Optional) Linux Ubuntu 22.04 or above version (Optional)		
Storage	1 x M.2 Key B SSD 128GB (up to 1TB, Optional)		
WLAN	Optional		
Bluetooth	Optional		
Input / Output			
USB Ports	2 x USB 3.2 Gen 1x1 (Type A),		
COM Port	1 x RS232/422/485 (Default RS232)		
LAN	2 x Giga LAN RJ45		
Expansion Port	1 x M.2 Key E		
Video	1 x HDMI 2.0 (Optional)		
Power Specifications			
Power Input	12V DC / 9~ 36V (Optional)		
Adapter	12V 50W		
Environment Considerations			
Operating Temp.	0 ~ 50 °C		
Operating Humidity	10 ~ 90% (non-condensing)		
Storage Temperature	-20 ~ 60 °C		
IP rating	Front IP65		
Shock/ Vibration	MIL-STD-810G (Method 514.6)		
Certification			
Certification	CE, FCC		

Note:

1. The product shown in this datasheet is a standard model. For diagrams that contain customized or optional I/O, please contact the Winmate Sales Team for more information.
2. All specifications are subject to change without prior notice.



Contact Us

Winmate Inc.



No.18, Zhongxing South Rd.,
San-Chung District, New Taipei City 241017, Taiwan
Tel: +886-2-8511-0288
E-mail: sales@winmate.com.tw
Website: www.winmate.com

Winmate USA Inc.



2640 Matthews Street,
Smyrna, GA 30080, USA
Tel: +1-678-653-8800
E-mail: NASales@winmate.com.tw
Website: www.winmate-rugged.com

TTX Canada



150 Werlich Drive, Units 5&6
Cambridge, Ontario, N1T 1N6 Canada
Tel: +1-519-621-1881
E-mail: Sales@ttx.ca
Website: www.ttx.ca

TL Electronic GmbH



Bgm.-Gradl-Str. 1
85232 Bergkirchen-Feldgeding, Germany
Tel: +49 (0)8131 33204-0
E-mail: info@tl-electronic.de
Website: www.tl-electronic.de

京融电自动化科技(苏州)有限公司



215100 江苏省苏州市工业园区唯新路 69 号
一能科技园 3 号楼 206 室
Tel: +86-512-6826-6696/6829-6696
E-mail: sales@winmate.com.cn
Website: www.winmate.com.cn

Winmate JP Office/ HPC System Inc.



LOOP-X 8F,3-9-15 Kaigan,
Minato-ku, Tokyo 108-0022, Japan
Tel: +81-3-5446-5535
Fax: +81-3-5446-5550
Website: www.hpc.co.jp
