

W24IE3S-PTA2

24" Intel® Celeron® N6211 PT Series HMI Touch Panel PC



KEY FEATURES

- Low power consumption with Intel® Celeron® Elkhart Lake N6211 processor
- Fanless cooling system and ultra-low power consumption
- Front IP65 for protection against water and dust
- A true flat, easy-to-clean front surface with edge-to-edge design

INTRODUCTION

Winmate PT Series HMI offers a versatile solution for industrial automation, available in sizes from 15" to 24". Designed for various operating systems, it features low power consumption, a fanless cooling system, and supports Windows or Android OS. Its true-flat, edge-to-edge design ensures easy cleaning, while front IP65 protection safeguards against water and dust. With PCAP touchscreen options and multiple I/O ports, including LAN, USB, and CANBUS, the PT Series HMI is ideal for manufacturing, process control, and smart factory applications.

SPECIFICATIONS

Display

Resolution	1920x1080	Size	24.0 inches
Contrast Ratio	3000:1	Panel Brightness	250.0 nits
View Angles	89,89,89,89	Active Area	527.04x296.46 mm
Touch / Glass	Projected Capacitive Multi Touch Screen		

System Specification

WLAN	Support (Optional)	BT	Support (Optional)
Processor	Intel® Celeron® N6211 (up to 3.0GHz)	Memory	1 x SO-DIMM, DDR4 3200 MHz, 4GB (Default) 8GB (Optional) 16GB (Optional)
Storage	1 x M.2 2242 B-key SSD 128GB (Default) 256GB (Optional) 512GB 1 x SATA III for 2.5" SSD/HDD up to 1TB (Optional)	Ethernet controller	2 x Intel® Ethernet Controller
Security	TPM 2.0	Operating System	Windows 11 IoT Enterprise (64 bit) (Optional) Windows 11 Pro 64 bit (Optional) Windows 10 IoT Enterprise (64 bit) (Optional) Linux Ubuntu 22.04 (Optional)

Environment

Operating Humidity	10% to 90% RH, Non-Condensing	Operating Temperature	0°C to 50°C
Storage Temperature	-10°C to 60°C	IP rating	Front IP65

Certification

Certification	CE, FCC
----------------------	---------

Mechanical

Dimension	588 x 358 x 60 mm	Mounting	VESA mount
Enclosure	Plastic	Cooling System	Fanless Design
IO Ports			
USB Port	2 x USB3.2 Gen1x1 (Type-A)	Serial Port	1 x RS232(Default)/422/485
Video	1 x HDMI 2.0 (Optional)	Audio	2 x Speaker (Optional)
LAN	2 x RJ45-10/100/1000 Mbps	Indicator	Power LED Indicator
Power			
Power Rating	12V DC		
Control			
Button	1 x Power Button 1 x Reset Button		
Accessory			
Accessory	Quick Start Guide(Hardcopy) AC Adapter 12V/50W Power Cord		

DIMENSIONS UNIT:MM

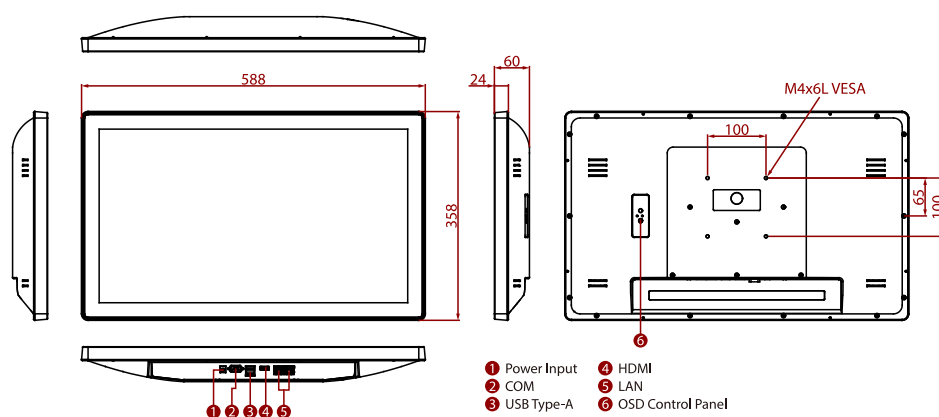

NOTE

- 1.This is a simplified drawing and some components are not marked in detail.
- 2.Please contact our sales representative if you need further product information.
- 3.All specifications are subject to change without prior notice.
- 4.The product shown in this datasheet is a standard model.For diagrams that contain customized or optional I/ O, please contact the Winmate Sales Team for more information.