

MTH556

Embedded 3.5" SBC
User's Manual

Copyright

This publication contains information that is protected by copyright. No part of it may be reproduced in any form or by any means or used to make any transformation/adaptation without the prior written permission from the copyright holders.

This publication is provided for informational purposes only. The manufacturer makes no representations or warranties with respect to the contents or use of this manual and specifically disclaims any express or implied warranties of merchantability or fitness for any particular purpose. The user will assume the entire risk of the use or the results of the use of this document. Further, the manufacturer reserves the right to revise this publication and make changes to its contents at any time, without obligation to notify any person or entity of such revisions or changes.

Changes after the publication's first release will be based on the product's revision. The website will always provide the most updated information.

© 2025. All Rights Reserved.

Trademarks

Product names or trademarks appearing in this manual are for identification purpose only and are the properties of the respective owners.

FCC and DOC Statement on Class B

This equipment has been tested and found to comply with the limits for a Class B digital device, pursuant to Part 15 of the FCC rules. These limits are designed to provide reasonable protection against harmful interference when the equipment is operated in a residential installation. This equipment generates, uses and can radiate radio frequency energy and, if not installed and used in accordance with the instruction manual, may cause harmful interference to radio communications. However, there is no guarantee that interference will not occur in a particular installation. If this equipment does cause harmful interference to radio or television reception, which can be determined by turning the equipment off and on, the user is encouraged to try to correct the interference by one or more of the following measures:

- Reorient or relocate the receiving antenna.
- Increase the separation between the equipment and the receiver.
- Connect the equipment into an outlet on a circuit different from that to which the receiver is connected.
- Consult the dealer or an experienced radio TV technician for help.

Notice:

1. The changes or modifications not expressly approved by the party responsible for compliance could void the user's authority to operate the equipment.
2. Shielded interface cables must be used in order to comply with the emission limits.

Table of Contents

Chapter 1 - Introduction.....	6
Specifications	6
Block Diagram	8
Dimension	8
Chapter 2 - Hardware Installation.....	9
Board Layout.....	9
Top View.....	9
Bottom View.....	9
Jumper Settings	11
Clear CMOS (SW1)	11
Panel Backlight Selection (DPJP1)	11
Panel Inverter Power Selection (DPJP2)	12
Panel Power (DPJP3)	12
Pin Assignment	13
RTC Battery (CN7)	13
System Fan (CN13)	13
DC IN (CN5)	14
I2C (CN6).....	14
Front Panel (J2).....	15
Audio (AUCN1).....	15
USB2.0 (UBCN4).....	16
DIO (CN12).....	16
COM1 (TSCN1)	17
COM2 (TSCN4).....	17
COM3 (TSCN11).....	18
COM4 (TSCN2).....	18
LVDS (DPCN1).....	19
Expansion Slots.....	20
Installing the M.2 Module	20
Chapter 3 - BIOS Settings.....	22
Overview	22
Main.....	23
Advanced	23
CPU Configuration.....	24
Power & Performance	24
Power & Performance ▶ CPU- Power Management Control	25
Power & Performance ▶ GT- Power Management Control	25
System Agent (SA) Configuration	26
PCIe Configuration	26
PCH-IO Configuration	27
PCH-IO Configuration ▶ SATA Configuration	27
PCH-IO Configuration ▶ HD Audio Configuration	28
PCH-FW Configuration	28
Trusted Computing.....	29
IT8786 Super IO Configuration.....	29
IT8786 Super IO Configuration ▶ Serial Port 1, 2 Configuration	30
IT8786 Super IO Configuration ▶ Serial Port 3, 4 Configuration	30
IT8786 Hardware Monitor.....	31
IT8786 Hardware Monitor ▶ Smart FAN Function	31
Serial Port Console Redirection	32
Serial Port Console Redirection ▶ Console Redirection Settings.....	32
ACPI Settings	33
Network Stack Configuration.....	34
DFI WDT Configuration.....	34

USB Power Control.....	35
Security	35
Secure Boot.....	36
Boot	36
Save & Exit	37
Updating the BIOS.....	37
Notice: BIOS SPI ROM.....	37
Chapter 4 - Mating Connectors List	38

About this Manual

This manual can be downloaded from the website.

The manual is subject to change and update without notice, and may be based on editions that do not resemble your actual products. Please visit our website or contact our sales representatives for the latest editions.

Warranty

1. Warranty does not cover damages or failures that occur from misuse of the product, inability to use the product, unauthorized replacement or alteration of components and product specifications.
2. The warranty is void if the product has been subjected to physical abuse, improper installation, modification, accidents or unauthorized repair of the product.
3. Unless otherwise instructed in this user's manual, the user may not, under any circumstances, attempt to perform service, adjustments or repairs on the product, whether in or out of warranty. It must be returned to the purchase point, factory or authorized service agency for all such work.
4. We will not be liable for any indirect, special, incidental or consequential damages to the product that has been modified or altered.

Static Electricity Precautions

It is quite easy to inadvertently damage your PC, system board, components or devices even before installing them in your system unit. Static electrical discharge can damage computer components without causing any signs of physical damage. You must take extra care in handling them to ensure against electrostatic build-up.

1. To prevent electrostatic build-up, leave the system board in its anti-static bag until you are ready to install it.
2. Wear an antistatic wrist strap.
3. Do all preparation work on a static-free surface.
4. Hold the device only by its edges. Be careful not to touch any of the components, contacts or connections.
5. Avoid touching the pins or contacts on all modules and connectors. Hold modules or connectors by their ends.



Important:

Electrostatic discharge (ESD) can damage your processor, disk drive and other components. Perform the upgrade instruction procedures described at an ESD workstation only. If such a station is not available, you can provide some ESD protection by wearing an antistatic wrist strap and attaching it to a metal part of the system chassis. If a wrist strap is unavailable, establish and maintain contact with the system chassis throughout any procedures requiring ESD protection.

Safety Measures

- To avoid damage to the system, use the correct AC input voltage range.
- To reduce the risk of electric shock, unplug the power cord before removing the system chassis cover for installation or servicing. After installation or servicing, cover the system chassis before plugging the power cord.

About the Package

The package contains the following items. If any of these items are missing or damaged, please contact your dealer or sales representative for assistance.

- 1 MTH556 motherboard
- 1 Cooler

The board and accessories in the package may not come similar to the information listed above. This may differ in accordance with the sales region or models in which it was sold. For more information about the standard package in your region, please contact your dealer or sales representative.

Before Using the System Board

When installing the system board in a new system, you will need at least the following internal components.

- Memory module
- Storage device such as a hard disk drive
- Power supply

External system peripherals may also be required for navigation and display, including at least a keyboard, a mouse and a video display monitor.

Chapter 1 - Introduction

► Specifications

SYSTEM	Processor	Intel® Core™ Ultra Processors, TDP up to 28W (Code Name: Meteor Lake) Intel® Core™ Ultra 7 165H, 16C, 24M Cache, 1.4GHz (5.0GHz) Intel® Core™ Ultra 5 135H, 14C, 18M Cache, 1.7GHz (4.6GHz) Intel® Core™ Ultra 7 155U, 12C, 12M Cache, 1.7GHz (4.8GHz) Intel® Core™ Ultra 5 125U, 12C, 12M Cache, 1.3GHz (4.3GHz) (Code Name: Arrow Lake) Intel® Core™ Ultra 7 255U, 12C, 12M Cache, 2.0GHz (5.2GHz) Intel® Core™ Ultra 5 225U, 12C, 12M Cache, 1.5GHz (4.8GHz)
	Memory	Two 262-Pin DDR5-5600 SO-DIMM up to 96GB
	BIOS	AMI SPI 256Mbit
GRAPHICS	Controller	165H/135H: Intel® Arc™ Graphics 255U/225U/155U/125U: Intel® Graphics
	Feature	OpenGL 4.6, Direct X 12.1, OpenCL 3.0 HW Decode: HEVC, VP9, AV1, AVC HW Encode: HEVC, VP9, AV1, AVC
	Display	1 x HDMI 1.4b, resolution up to 4096x2160@24Hz 1 x LVDS, dual channel 24-bit, resolution up to 1920x1200@60Hz 1 x USB-C DP Alt. mode, resolution up to 4096x2304@60Hz
	Triple Displays	HDMI + LVDS + USB-C DP Alt. mode
EXPANSION	Interface	1 x M.2 M key 2280 (PCIe Gen4 x4) 1 x M.2 B key 3052(USB 3.0/2.0, PCIe Gen4 x1, SATA), 1 x SIM slot for 4G/5G 1 x M.2 E key 2230 (USB 2.0/PCIe Gen4 x1)
ETHERNET	Controller	2 x Intel® I226V/I226LM (10/100/1000/2500Mbps)
FRONT I/O	Ethernet	2 x 2.5GHz RJ45
	USB	3 x USB 3.2 Gen2 x1 (Type A) 1 x USB 3.2 Gen2 x2 (Type C)
	Display	1 x USB-C DP Alt. Mode 1 x HDMI
INTERNAL I/O	Serial	2 x RS-232/422/485 2 x RS-232 (1.0mm pitch)
	USB	2 x USB 2.0 (1.0mm pitch)
	DIO	1 x 8-bit DIO (4 in, 4 out)
	Audio	1 x Audio (Line_out/Mic_in)
	Fan	1 x Smart Fan (3-pin, 12V)

WATCHDOG TIMER	Output & Interval	System Reset, Programmable via Software from 1 to 255 Seconds
SECURITY	TPM	TPM 2.0
POWER	Type	9~36V DC
	Connector	Right Angle Connector (ATX 4-pin) Vertical connector (ATX 4-pin) (available upon request)
	RTC Battery	CR2032 Coin Cell (Cable type)
	Power Consumption	Typical: 165H (28W), 36V @ 0.31A (11.16W) Max: 165H (28W), 36V @ 2.37A (85.32W) Typical: 265U (15W), 36V @ 0.29A (10.44W) Max: 265U (15W), 36V @ 2.19A (78.84W)
OS SUPPORT	Microsoft	Windows 11 & 10 IoT Enterprise 64-bit
	Linux	Linux
ENVIRONMENT	Temperature	Operating: -5 to 65°C or -20 to 70°C (15W CPU only) Storage: -40 to 85°C
	Humidity	Operating: 5 to 90% RH Storage: 5 to 90% RH
	MTBF	379,660 hrs @ 25°C; 171,659 hrs @ 45°C; 78,131 hrs @ 60°C; 44,593 hrs @ 70°C Calculation Model: Telcordia Issue 4 Environment: GB, GC - Ground Benign, Controlled
MECHANISM	Dimensions	3.5" SBC Form Factor 146mm (5.75") x 102mm (4.02")
	Height	PCB: 1.6mm
STANDARDS AND CERTIFICATIONS	Certifications	CE, FCC Class B, RoHS

► Block Diagram

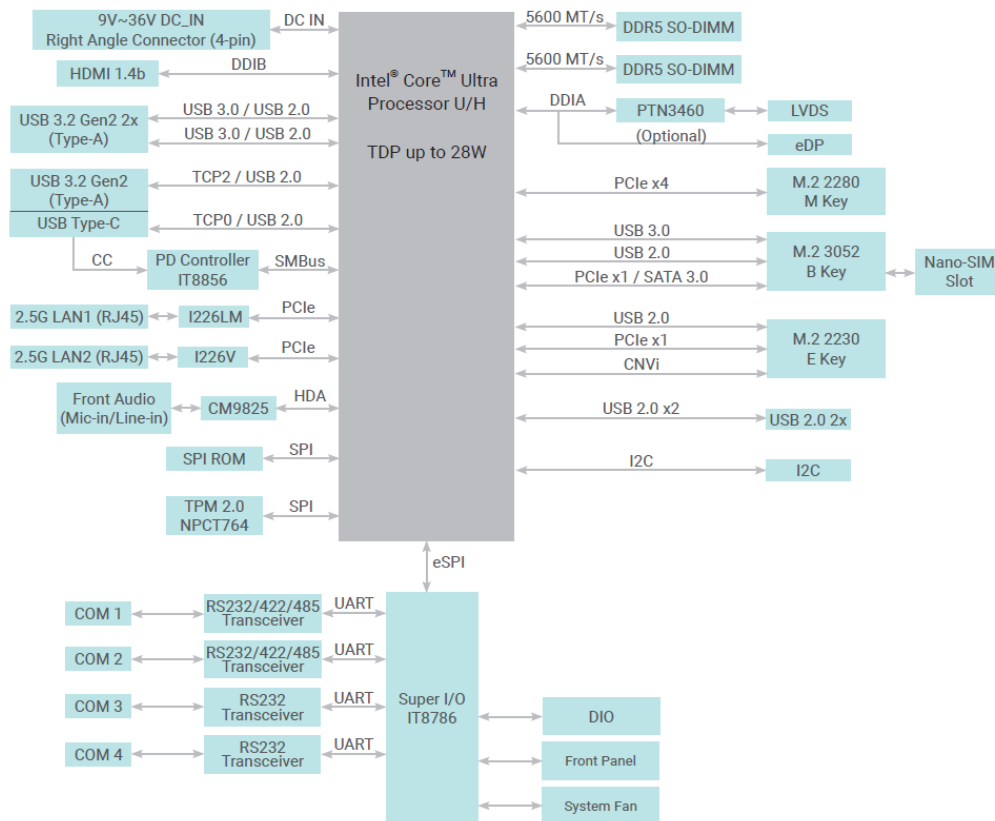

► Dimension

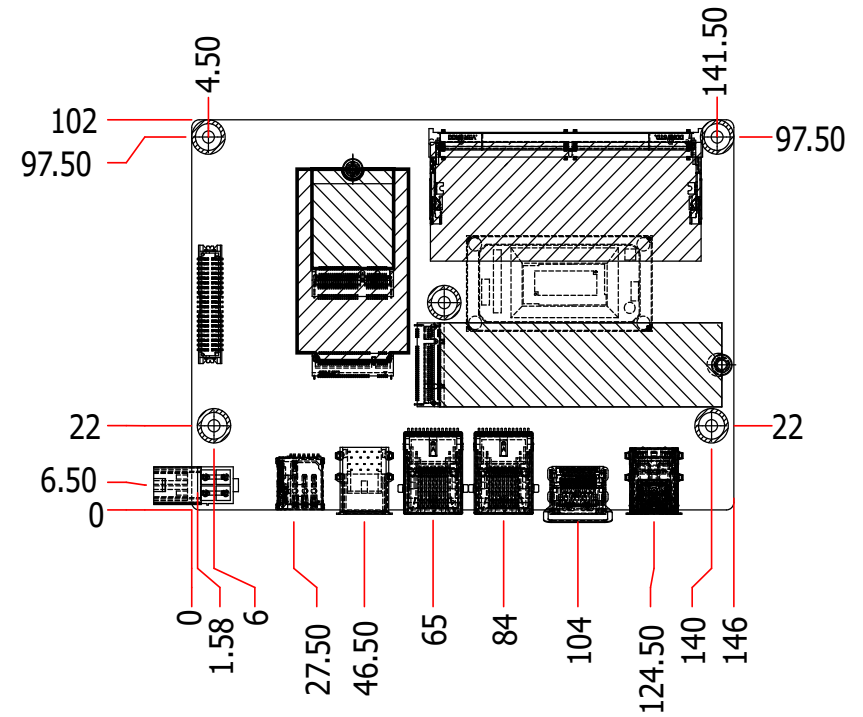

Chapter 2 - Hardware Installation

► Board Layout

Top View

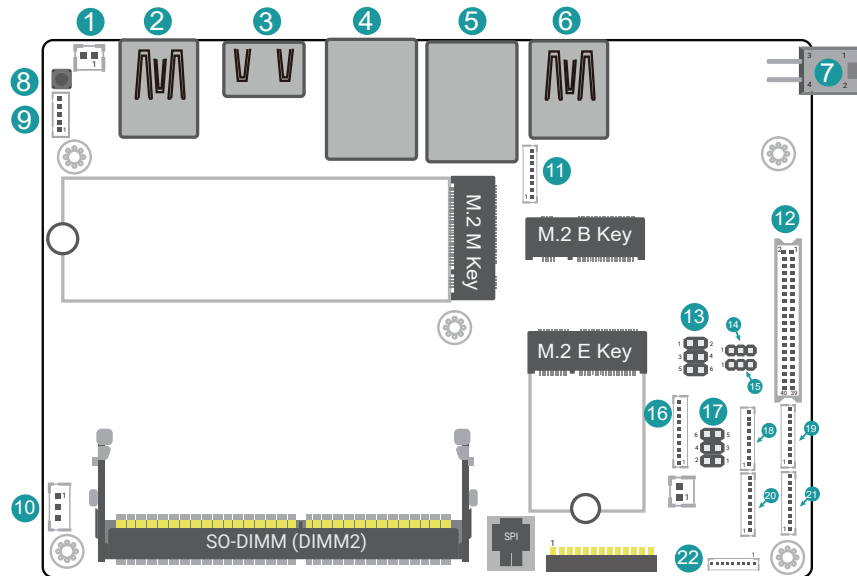

Bottom View

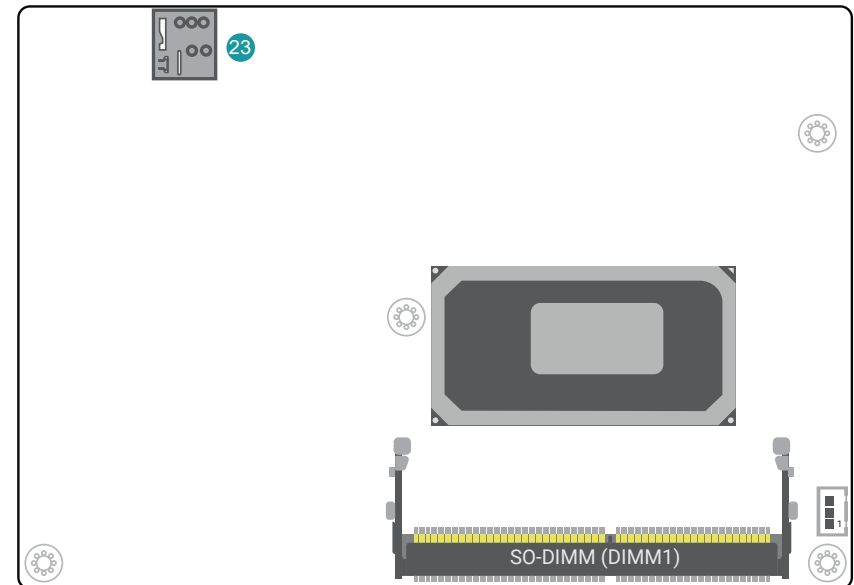

- 1 RTC Battery
- 2 ▲USB 3.2
▼USB Type C
- 3 HDMI
- 4 LAN2
- 5 LAN1
- 6 ▲USB3_2/1
▼USB3_2/2
- 7 DC IN
- 8 Clear CMOS
- 9 I2C
- 10 System Fan
- 11 USB2.0 2x
- 12 LVDS
- 13 Panel Power
- 14 Panel Inverter Power Selection
- 15 Panel Backlight Selection
- 16 DIO
- 17 Front Panel
- 18 COM2
- 19 COM1
- 20 COM4
- 21 COM3
- 22 Audio
- 23 SIM Card Slot

► Jumper Settings

Clear CMOS (SW1)

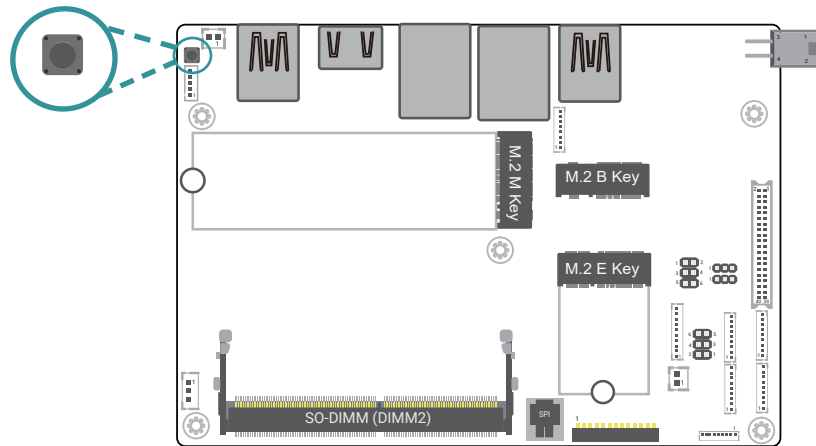

- 1-2 Open: Normal (default)
- 1-2 Short: Clear CMOS

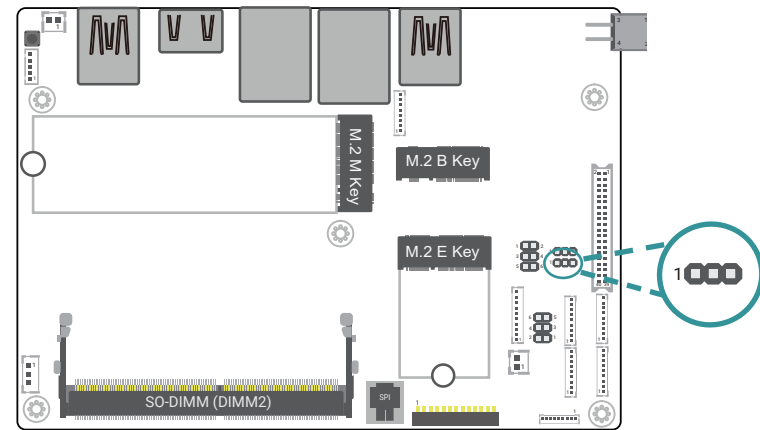

Panel Backlight Selection (DPJP1)



- 1-2 On: 3V3 (Default)
- 2-3 On: 5V

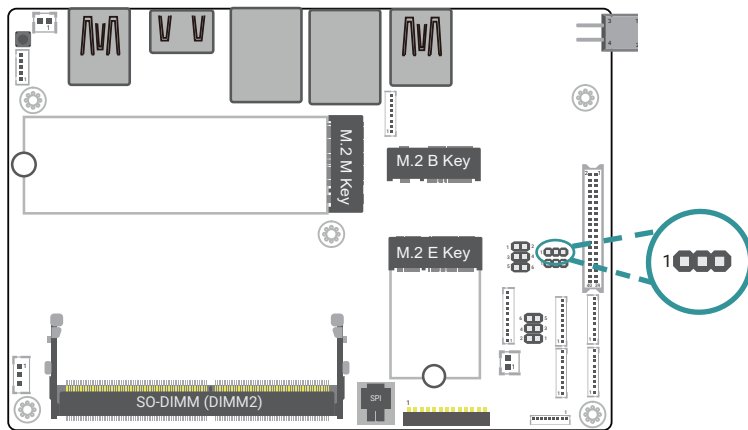

Panel Inverter Power Selection (DPJP2)

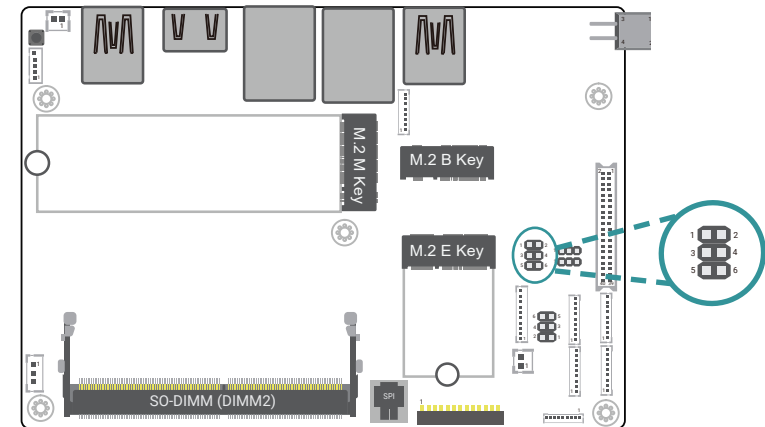

- 1 
 - 1-2 On: 12V (Default)
- 1 
 - 2-3 On: 5V

Panel Power (DPJP3)

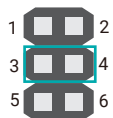

- 1  2
 - 1-2 On: 12V
- 1  2
 - 3-4 On: 5V
- 1  2
 - 5-6 On: 3V3 (Default)

► Pin Assignment

RTC Battery (CN7)

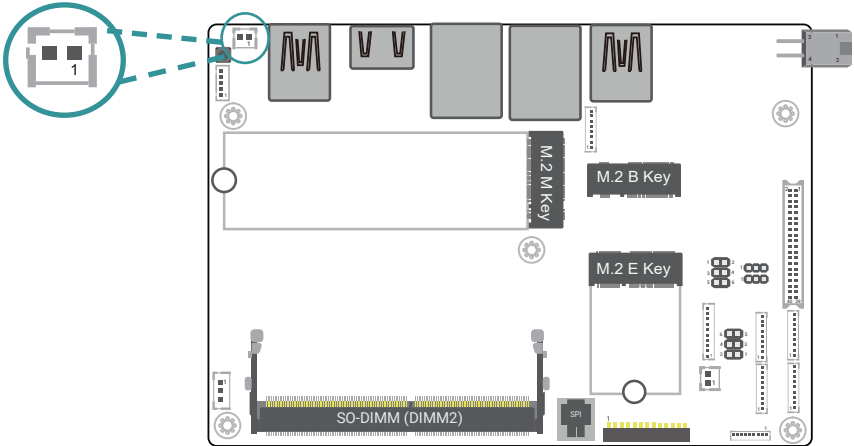

Pin	Assignment
1	RTC power
2	GND

System Fan (CN13)

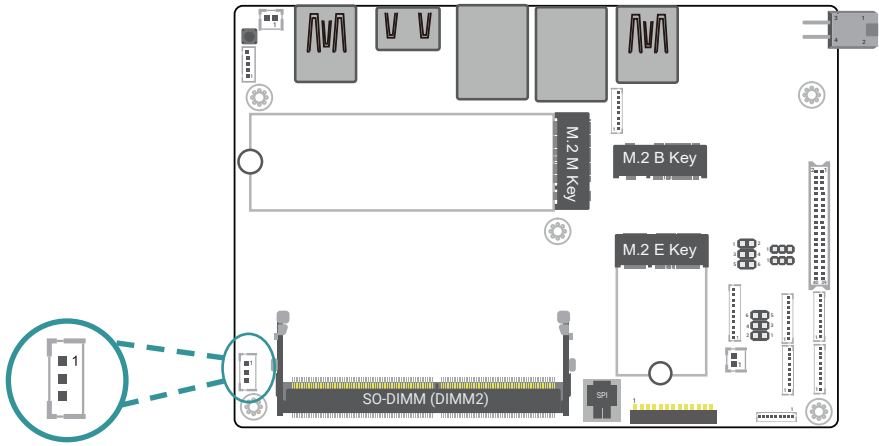

Pin	Assignment
1	TACT
2	+12V
3	GND

DC IN (CN5)

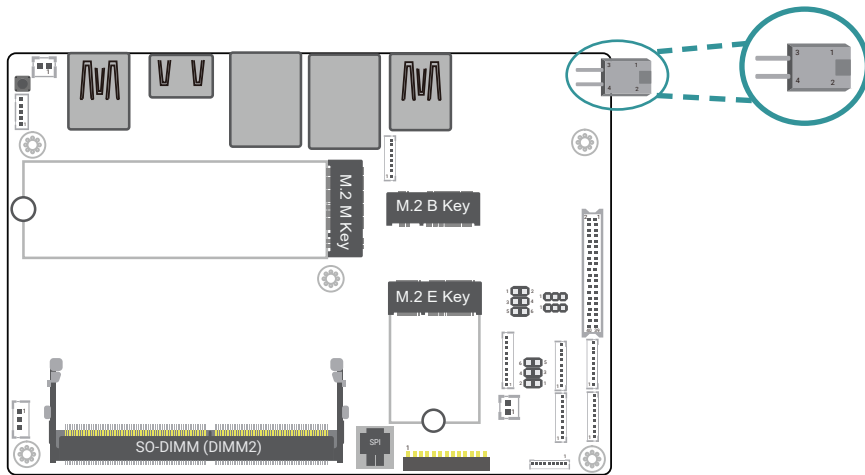

Pin	Assignment
1	GND
2	GND
3	DC_IN
4	DC_IN

I2C (CN6)

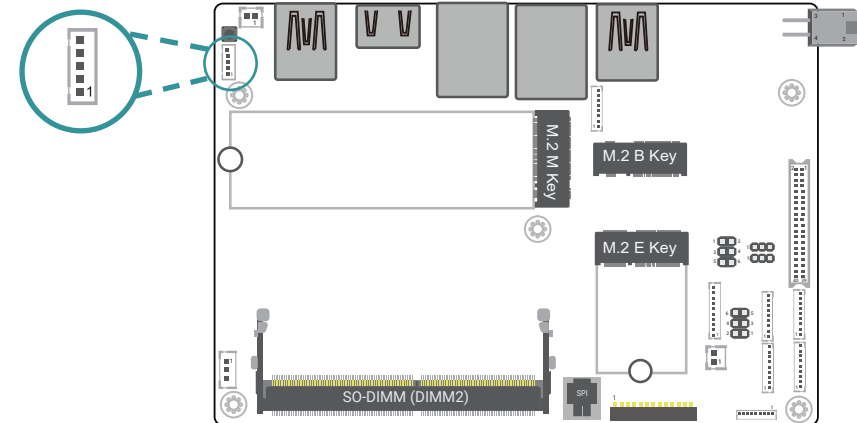

Pin	Assignment
1	3V3SB
2	GND
3	I2C1_SCL_SOC
4	I2C1_SDA_SOC
5	I2C1_INT#

Front Panel (J2)

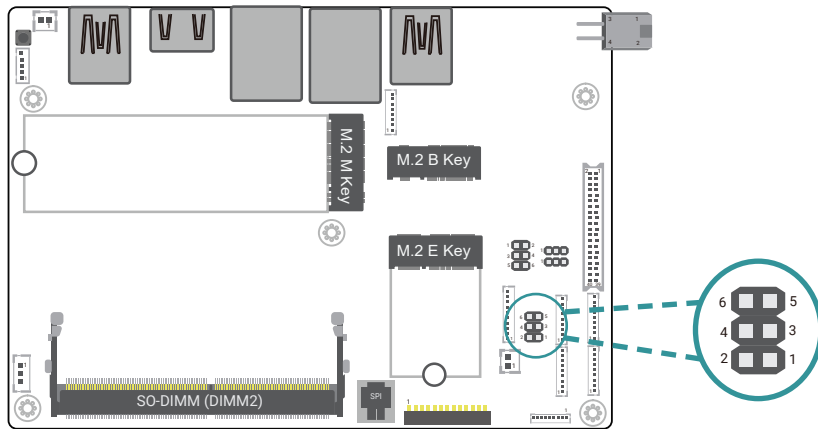

Pin	Assignment	Pin	Assignment
1	PWR_BTN0	2	3V3SB
3	GND	4	SUS_LED#
5	SYS_RST0	6	HD_LED#

Audio (AUCN1)

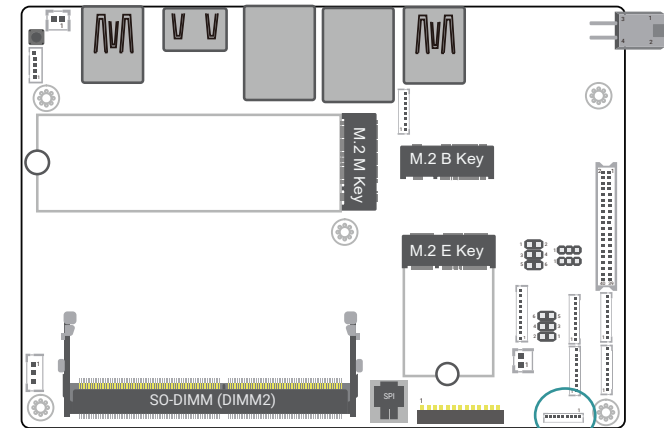

Pin	Assignment
1	LINE2-L
2	AGND_AUDIO
3	LINE2-R
4	HPOUT-R
5	MIC-JD
6	AGND_AUDIO
7	HPOUT-L
8	LINEOUT-JD

USB2.0 (UBCN4)

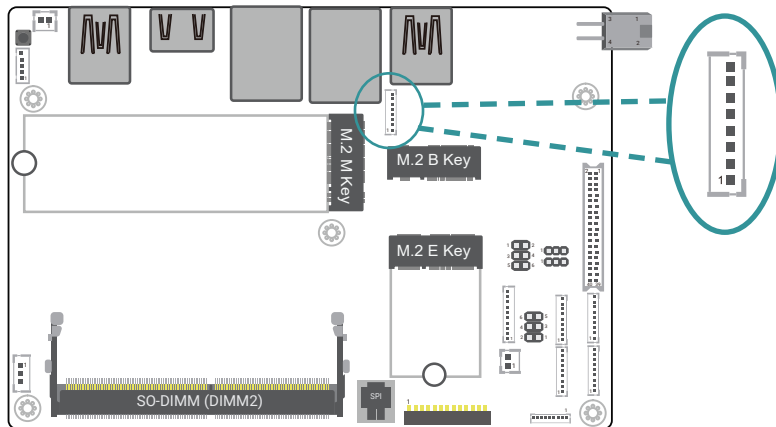

Pin	Assignment
1	5V
2	USB2_7_C_N
3	USB2_7_C_P
4	GND
5	5V
6	USB2_9_C_N
7	USB2_9_C_P
8	GND

DIO (CN12)

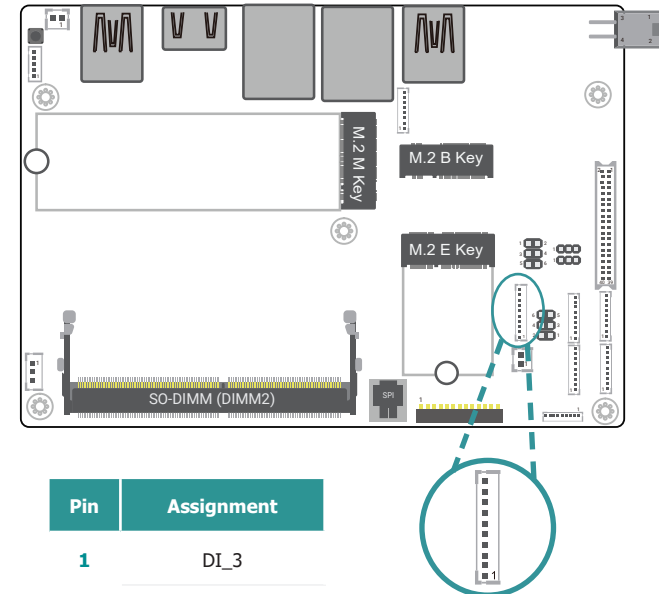

Pin	Assignment
1	DI_3
2	DI_2
3	DI_1
4	DI_0
5	DO_3
6	DO_2
7	DO_1
8	DO_0
9	5VSB
10	GND

COM1 (TSCN1)

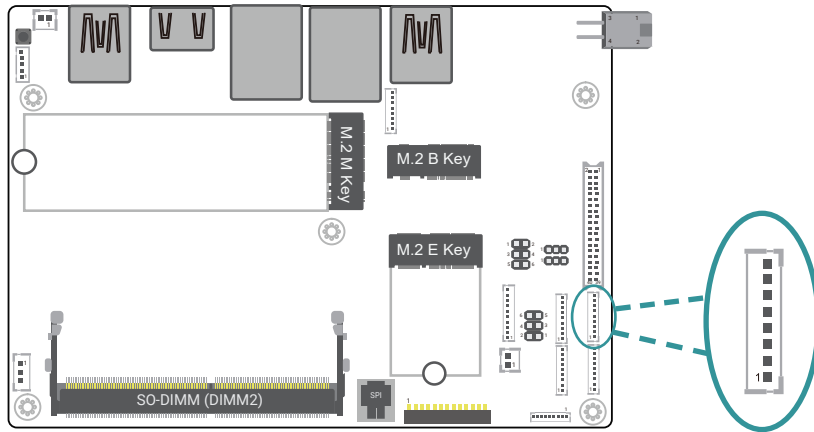

Pin	RS232	RS422 (HALF-2W)	RS422 (FULL-4W)	RS485 (HALF-2W)
1	DCD-	N.C	TX-	DATA-
2	SIN	N.C	TX+	DATA+
3	SOUT	RX+	RX+	N.C
4	DTR-	RX-	RX-	N.C
5	GND	N.C	GND	GND
6	DSR-	N.C	N.C	N.C
7	RTS-	N.C	N.C	N.C
8	CTS-	N.C	N.C	N.C
9	RI-	N.C	N.C	N.C
10	N.C	N.C	N.C	N.C

COM2 (TSCN4)

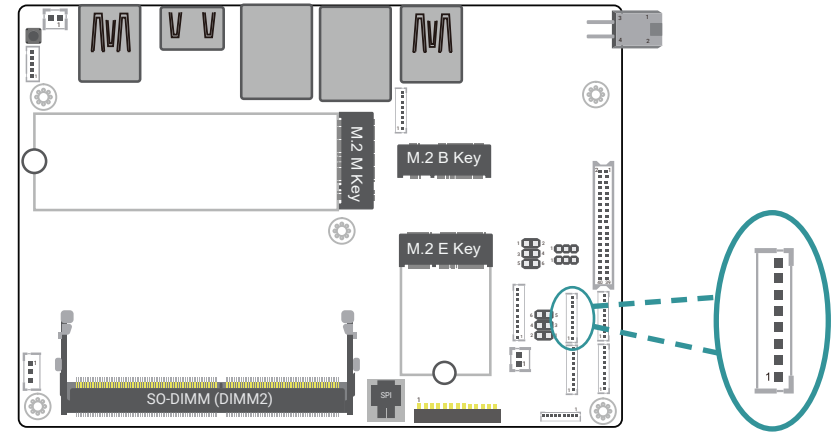

Pin	RS232	RS422 (HALF-2W)	RS422 (FULL-4W)	RS485 (HALF-2W)
1	DCD-	N.C	TX-	DATA-
2	SIN	N.C	TX+	DATA+
3	SOUT	RX+	RX+	N.C
4	DTR-	RX-	RX-	N.C
5	GND	N.C	GND	GND
6	DSR-	N.C	N.C	N.C
7	RTS-	N.C	N.C	N.C
8	CTS-	N.C	N.C	N.C
9	RI-	N.C	N.C	N.C
10	N.C	N.C	N.C	N.C

COM3 (TSCN11)

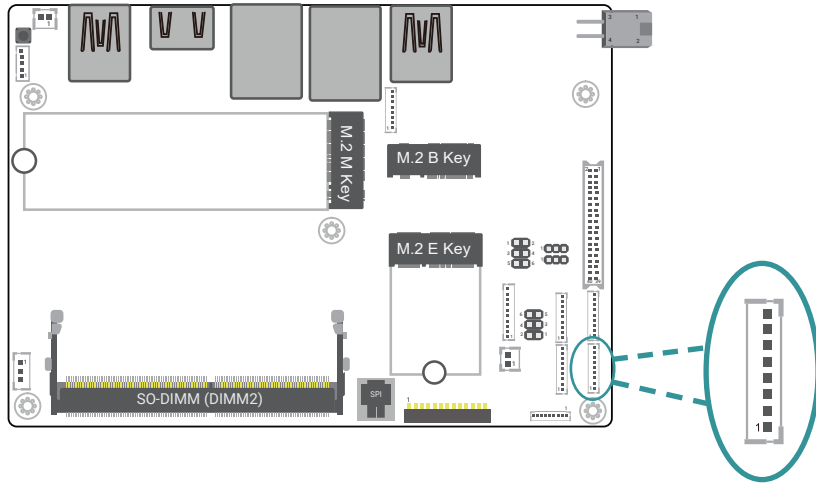

Pin	Assignment
1	MDCD-
2	MSIN
3	MSOUT
4	MDTR-
5	GND
6	MDSR-
7	MRTS-
8	MCTS-
9	MRI-

COM4 (TSCN2)

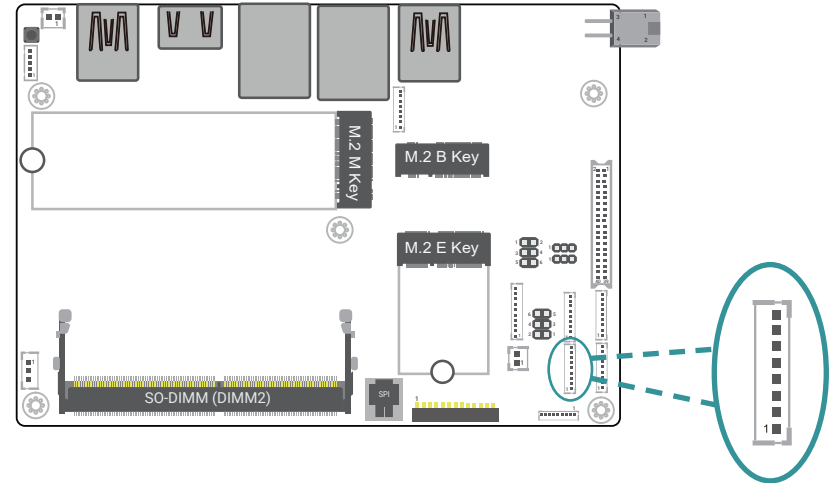

Pin	Assignment
1	MDCD-
2	MSIN
3	MSOUT
4	MDTR-
5	GND
6	MDSR-
7	MRTS-
8	MCTS-
9	MRI-

LVDS (DPCN1)

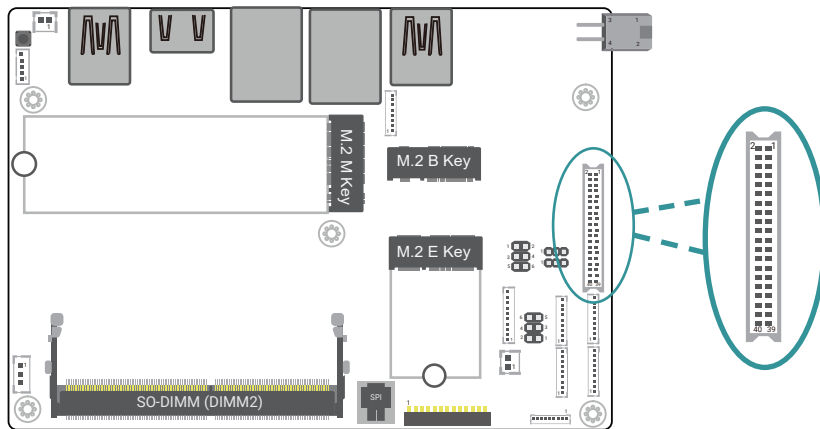

Pin	Assignment	Pin	Assignment
1	INV_PWR	2	INV_PWR
3	INV_PWR	4	INV_PWR
5	INV_PWR	6	GND
7	LVDS_3V3	8	GND
9	VCC_PANEL_PWR	10	VCC_PANEL_PWR
11	LVDS_DDC_CLK	12	LVDS_DDC_DATA
13	DIMMING	14	PVCCEN
15	BLONOFF	16	eDP_HPDP_CON
17	LVDSA_LANE0_N	18	LVDSA_LANE0_P
19	LVDSA_LANE1_N	20	LVDSA_LANE1_P
21	LVDSA_LANE2_N	22	LVDSA_LANE2_P
23	LVDSA_CLK_N	24	LVDSA_CLK_P
25	LVDSA_LANE3_N	26	LVDSA_LANE3_P
27	GND	28	GND
29	eDP_LVDSB_LANE0_N	30	eDP_LVDSB_LANE0_P
31	eDP_LVDSB_LANE1_N	32	eDP_LVDSB_LANE1_P
33	LVDSB_LANE2_N	34	LVDSB_LANE2_P
35	eDP_LVDSB_CLK_N	36	eDP_LVDSB_CLK_P
37	LVDSB_LANE3_N	38	LVDSB_LANE3_P
39	GND	40	GND

► Expansion Slots

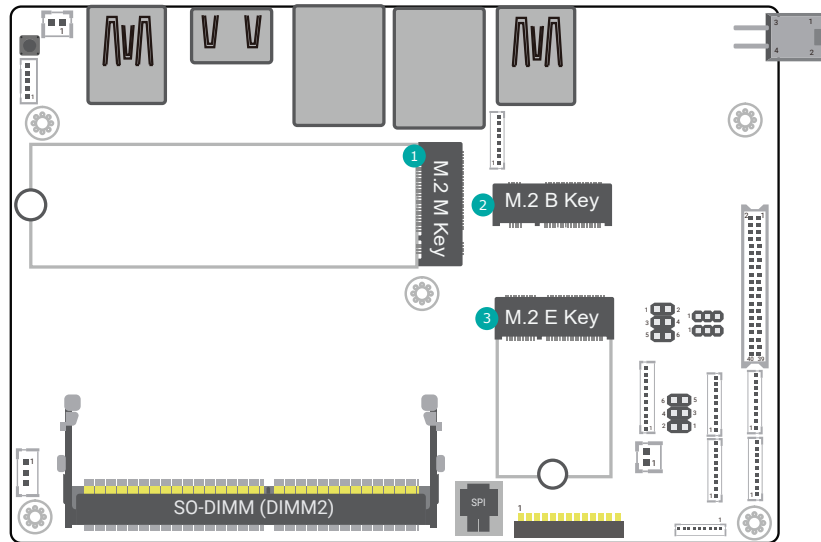

1 M.2 M-Key

2 M.2 B-Key

3 M.2 E-Key

Installing the M.2 Module

Before installing the M.2 module into the M.2 socket, please make sure that the following safety cautions are well-attended.

1. Make sure the PC and all other peripheral devices connected to it has been powered down.
2. Disconnect all power cords and cables.
3. Locate the M.2 socket on the system board
4. Make sure the notch on card is aligned to the key on the socket.
5. Make sure the standoff screw is removed from the standoff.

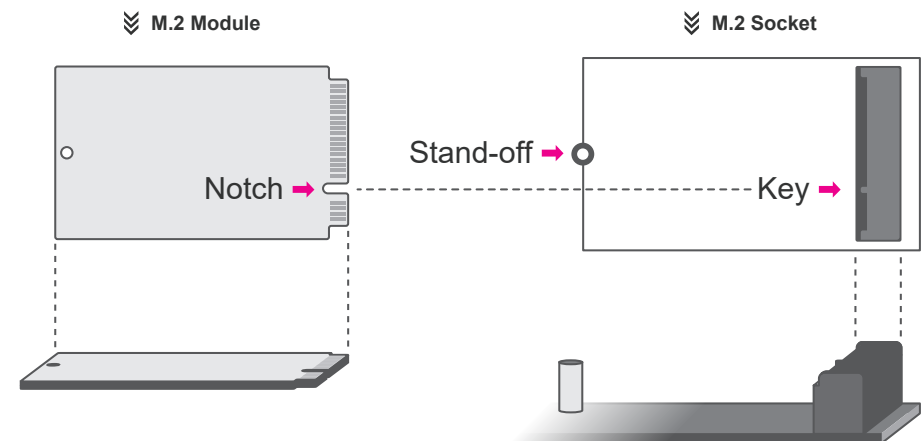

Please follow the steps below to install the card into the socket.

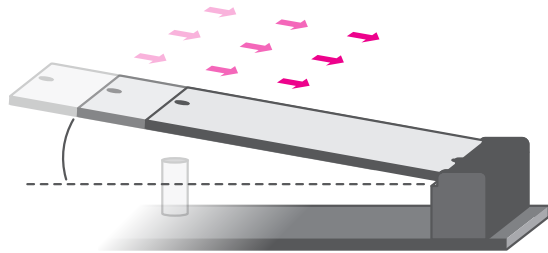

Step 1:
Insert the card into the socket at an angle while making sure the notch and key are perfectly aligned.

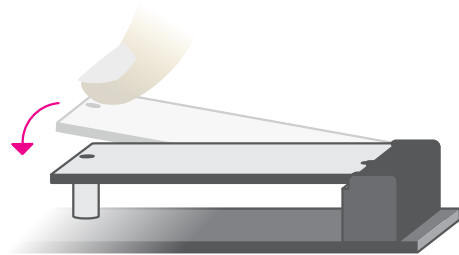

Step 2:
Press the end of the card far from the socket down until against the stand-off.

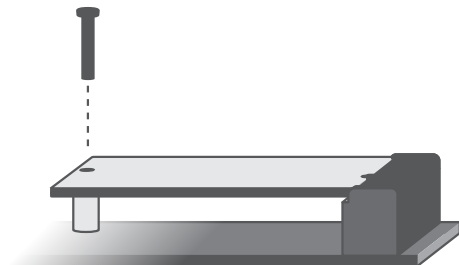

Step 3:
Screw tight the card onto the stand-off with a screw driver and a stand-off screw until the gap between the card and the stand-off closes up. The card should be lying parallel to the board when it's correctly mounted.

Chapter 3 - BIOS Settings

► Overview

The BIOS is a program that takes care of the basic level of communication between the CPU and peripherals. It contains codes for various advanced features found in this system board. The BIOS allows you to configure the system and save the configuration in a battery-backed CMOS so that the data retains even when the power is off. In general, the information stored in the CMOS RAM of the EEPROM will stay unchanged unless a configuration change has been made such as a hard drive replaced or a device added. It is possible that the CMOS battery will fail causing CMOS data loss. If this happens, you need to install a new CMOS battery and reconfigure the BIOS settings.



Note:

The BIOS is constantly updated to improve the performance of the system board; therefore the BIOS screens in this chapter may not appear the same as the actual one. These screens are for reference purpose only.

Default Configuration

Most of the configuration settings are either predefined according to the Load Optimal Defaults settings which are stored in the BIOS or are automatically detected and configured without requiring any actions. There are a few settings that you may need to change depending on your system configuration.

Entering the BIOS Setup Utility

The BIOS Setup Utility can only be operated from the keyboard and all commands are keyboard commands. The commands are available at the right side of each setup screen. The BIOS Setup Utility does not require an operating system to run. After you power up the system, the BIOS message appears on the screen and the memory count begins. After the memory test, the message "Press DEL to run setup" will appear on the screen. If the message disappears before you respond, restart the system or press the "Reset" button. You may also restart the system by pressing the <Ctrl> <Alt> and keys simultaneously.

Legends

Keys	Function
Right / Left arrow	Move the highlight left or right to select a menu
Up / Down arrow	Move the highlight up or down between submenus or fields
<Enter>	Enter the highlighted submenu
+ (plus key)/F6	Scroll forward through the values or options of the highlighted field
- (minus key)/F5	Scroll backward through the values or options of the highlighted field
<F1>	Display general help
<F2>	Display previous values
<F7>	Popup Boot Device List
<F9>	Optimized defaults
<F10>	Save and Exit
<Esc>	Return to previous menu

Scroll Bar

When a scroll bar appears to the right of the setup screen, it indicates that there are more available fields not shown on the screen. Use the up and down arrow keys to scroll through all the available fields.

Submenu

When "►" appears on the left of a particular field, it indicates that a submenu which contains additional options are available for that field. To display the submenu, move the highlight to that field and press <Enter>.

► Main

The Main menu is the first screen that you will see when you enter the BIOS Setup Utility.

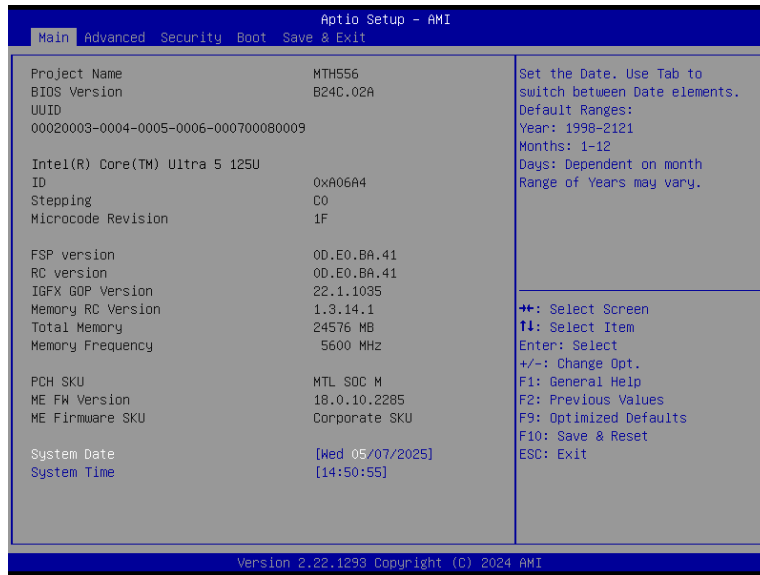

System Date

The date format is <month>, <date>, <year>. Press "Tab" to switch to the next field and press "-" or "+" to modify the value.

System Time

The time format is <hour>, <minute>, <second>. The time is based on the 24-hour military-time clock. For example, 1 p.m. is 13:00:00. Hour displays hours from 00 to 23. Minute displays minutes from 00 to 59. Second displays seconds from 00 to 59.

► Advanced

The Advanced menu allows you to configure your system for basic operation. Some entries are defaults required by the system board, while others, if enabled, will improve the performance of your system or let you set some features according to your preference.



Important:
Setting incorrect field values may cause the system to malfunction.

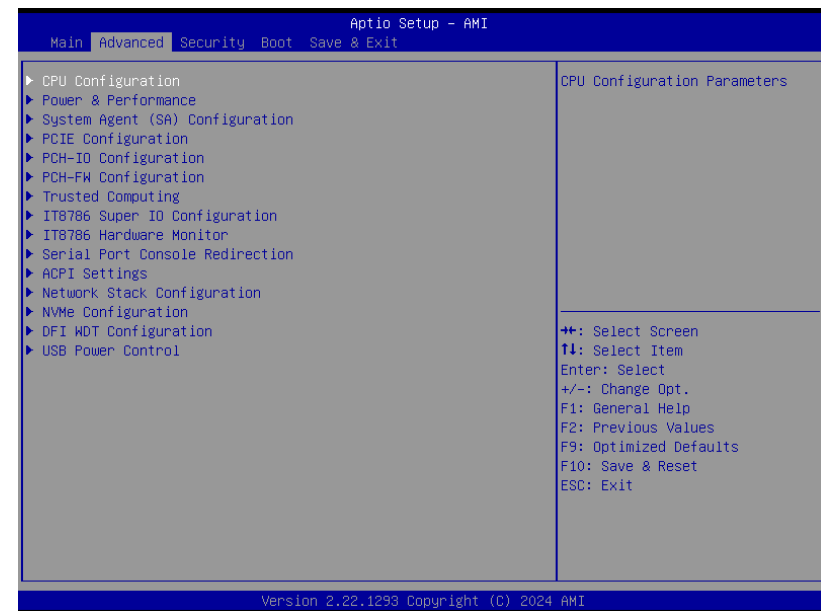

▶ Advanced

CPU Configuration

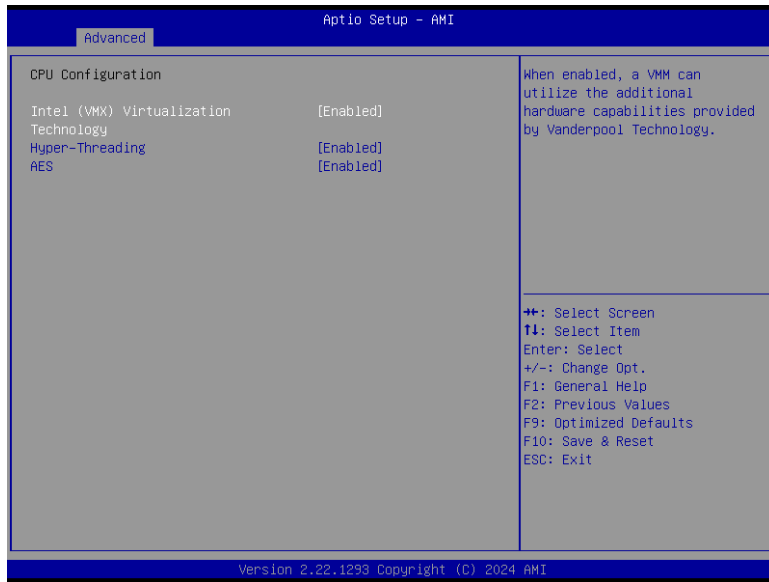

Intel (VMX) Virtualization Technology

When this field is set to Enabled, the VMM can utilize the additional hardware capabilities provided by Vanderpool Technology.

Hyper-threading

Enables this field for Windows XP and Linux which are optimized for Hyper-Threading technology. Select disabled for other OSes not optimized for Hyper-Threading technology. When disabled, only one thread per enabled core is enabled.

AES

Enable or disable AES function.

 **Note:**
Some of the fields may not be available when the features are not supported by the equipped CPU.

▶ Advanced

Power & Performance

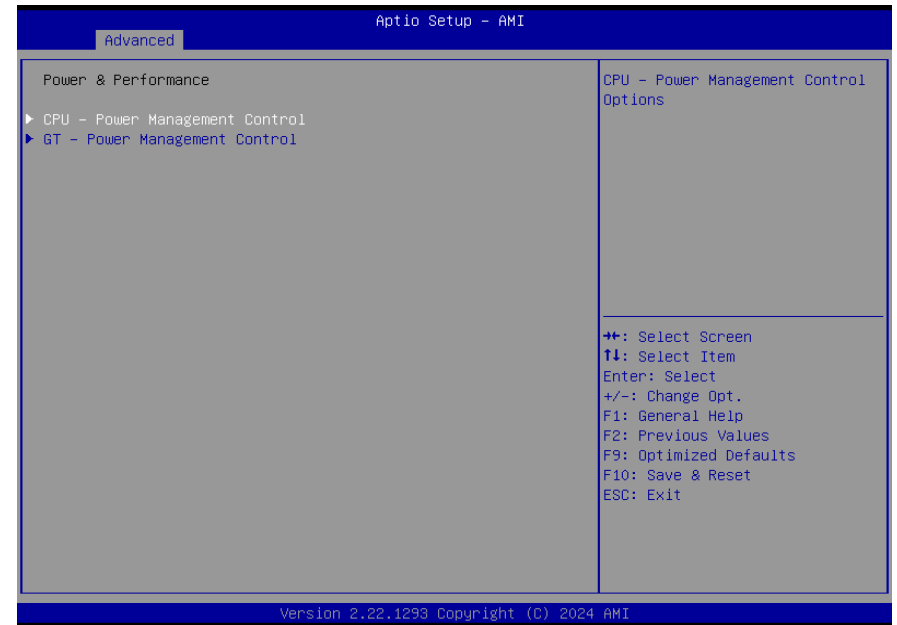

▶ **Advanced**

Power & Performance ▶ CPU- Power Management Control

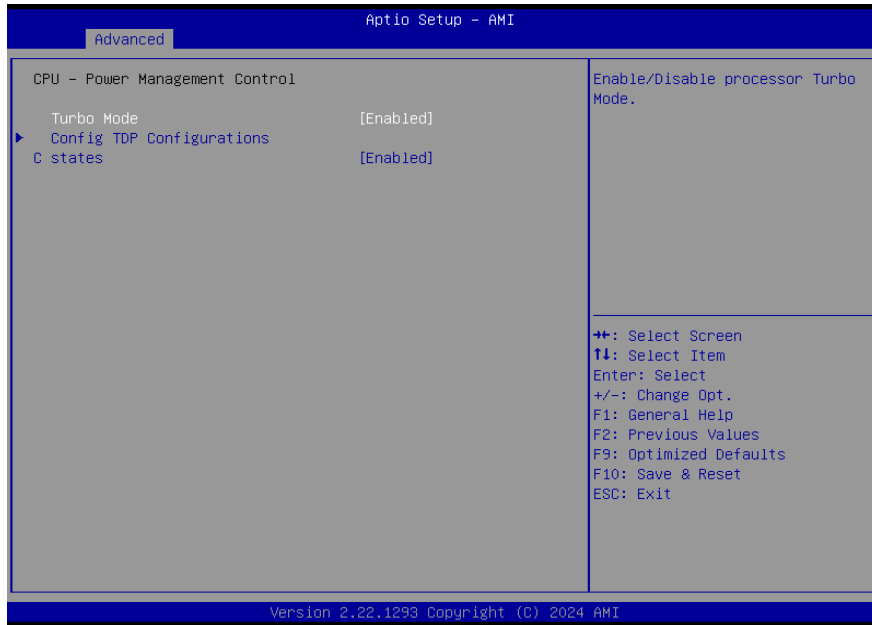

Turbo Mode

Enable/Disable processor Turbo Mode (requires EMTTM enabled too). AUTO means enabled.

C states

Enable or disable CPU Power Management. It allows CPU to enter "C states" when it's idle and nothing is executing.

▶ **Advanced**

Power & Performance ▶ GT- Power Management Control

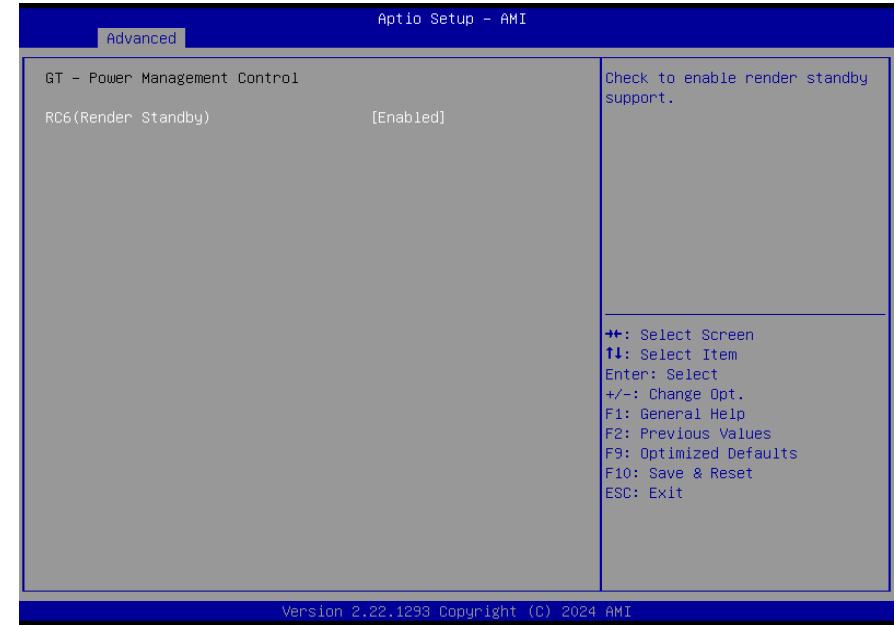

RC6 (Render Standby)

Check to enable render standby support.

▶ Advanced

System Agent (SA) Configuration

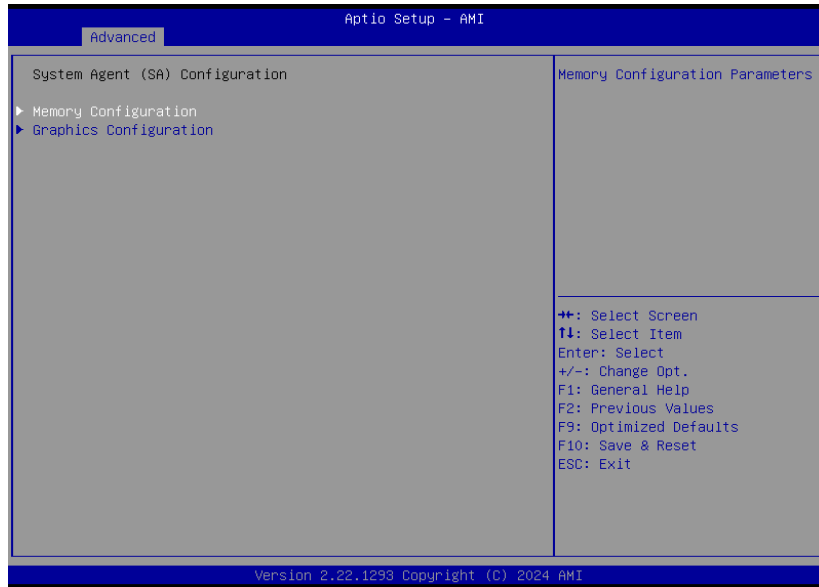

Memory Configuration

Memory Configuration Parameters

Graphics Configuration

Graphics Configuration

▶ Advanced

PCIe Configuration

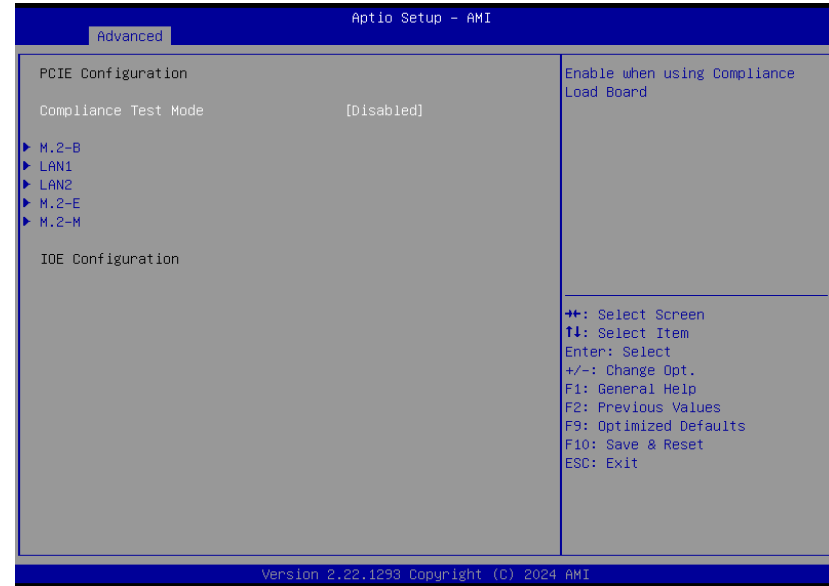

Select one of the PCI Express channels and press enter to configure the following settings.

LAN1, LAN2, M.2-E, M.2-B, M.2-M

Control the PCI Express Root Port.

▶ Advanced

PCH-IO Configuration



SATA Configuration

SATA Device Options Settings

HD Audio Configuration

HD Audio Subsystem Configuration Settings

USB-A and M.2 B Key switch

Choose TCP3 is used for USB-A or M.2 B key

▶ Advanced

PCH-IO Configuration ▶ SATA Configuration

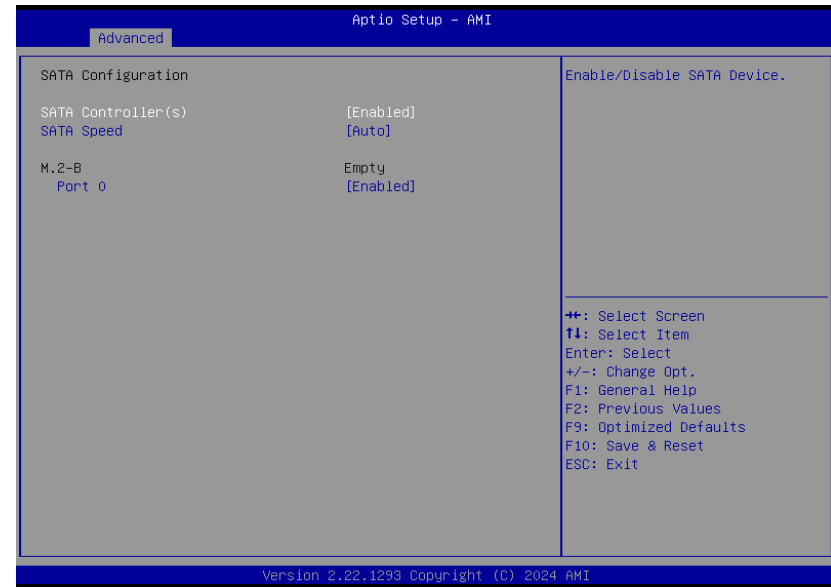

SATA Controller(s)

This field is used to enable or disable the Serial ATA controller.

SATA Speed

This field is used to select SATA speed generation limit: Auto, Gen1, Gen2 or Gen3.

Ports

Enable or disable the Serial ATA port function.

▶ Advanced

PCH-IO Configuration ▶ HD Audio Configuration

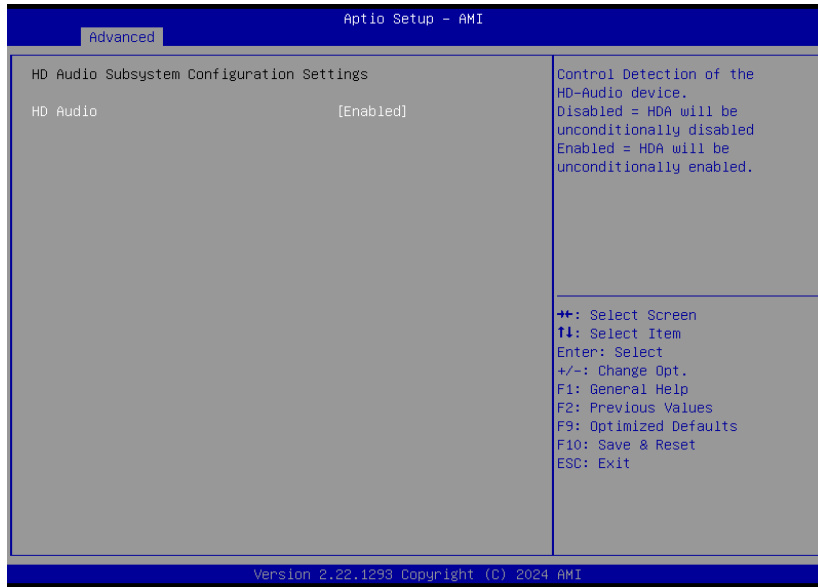

HD Audio

Control the detection of the HD Audio device.

- **Disabled** HDA will be unconditionally disabled.
- **Enabled** HDA will be unconditionally enabled.

▶ Advanced

PCH-FW Configuration

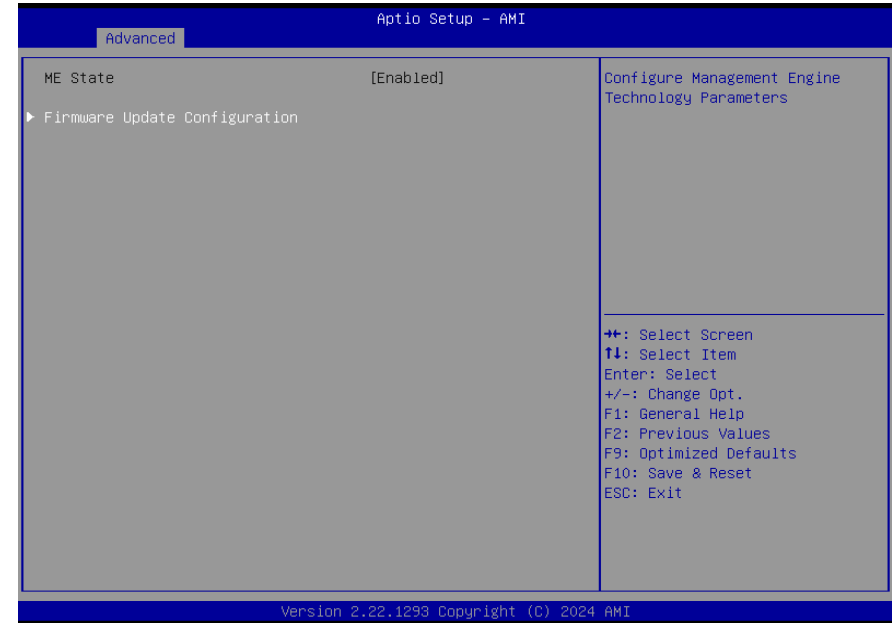

ME State

When this field is set to Disabled, ME will be put into ME Temporarily Disabled Mode.

Firmware Update Configuration

Configure Management Engine Technology Parameter



Note:
The sub-menus are detailed in following sections.

▶ Advanced

Trusted Computing



Security Device Support

This field is used to enable or disable BIOS support for the security device such as an TPM 2.0 to achieve hardware-level security via cryptographic keys.

Pending operation

To clear the existing TPM encryption, select "TPM Clear" and restart the system. This field is not available when "Security Device Support" is disabled.

▶ Advanced

IT8786 Super IO Configuration

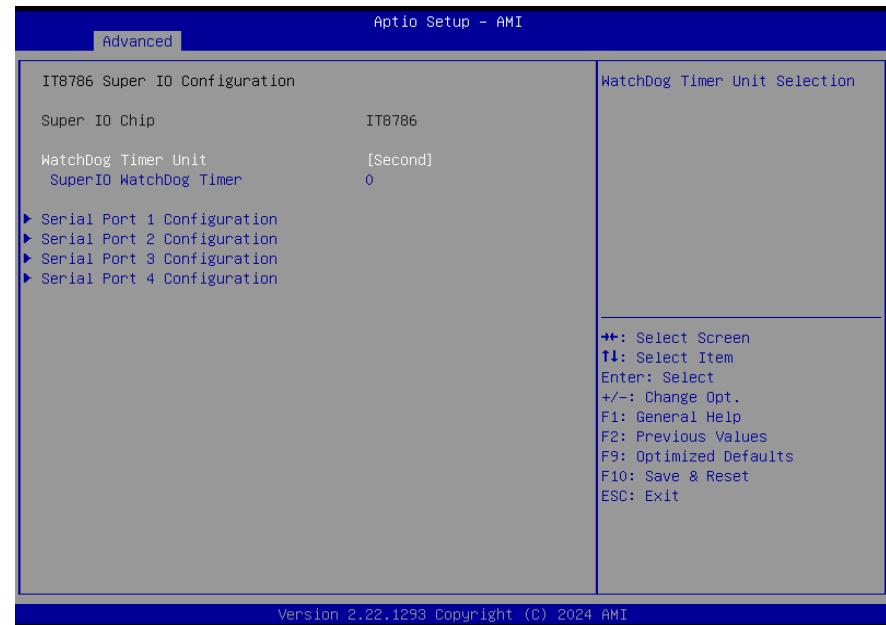

Note:
The sub-menus are detailed in following sections.

▶ **Advanced**

IT8786 Super IO Configuration ▶ Serial Port 1, 2 Configuration

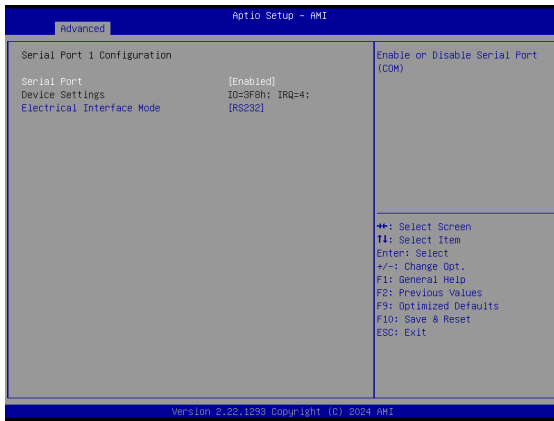

Serial Port
 Enable or disable serial port.

▶ **Advanced**

IT8786 Super IO Configuration ▶ Serial Port 3, 4 Configuration



Serial Port
 Enable or disable serial port.

▶ Advanced

IT8786 Hardware Monitor

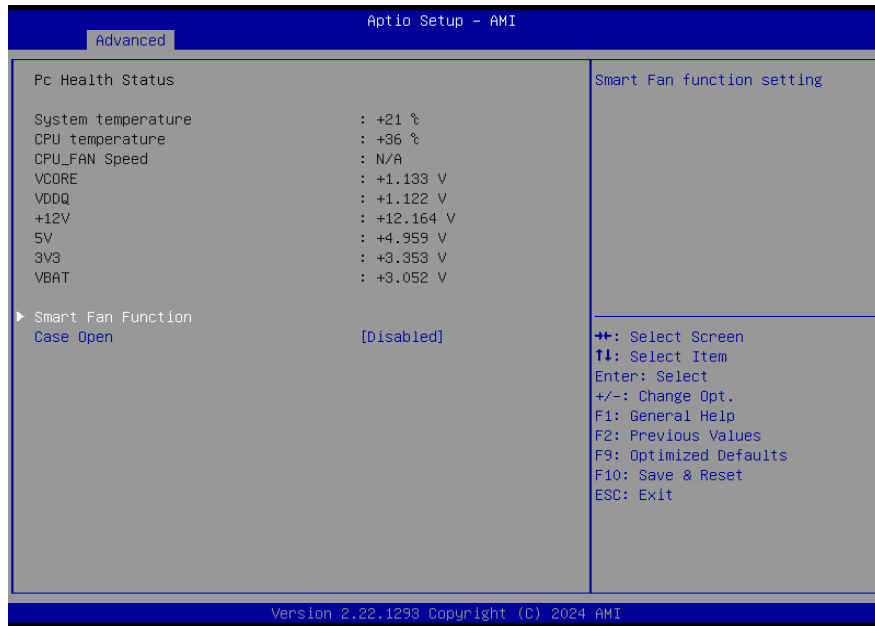

This section displays the system's health information, i.e. voltage readings, CPU and system temperatures, and fan speed readings

▶ Advanced

IT8786 Hardware Monitor ▶ Smart FAN Function

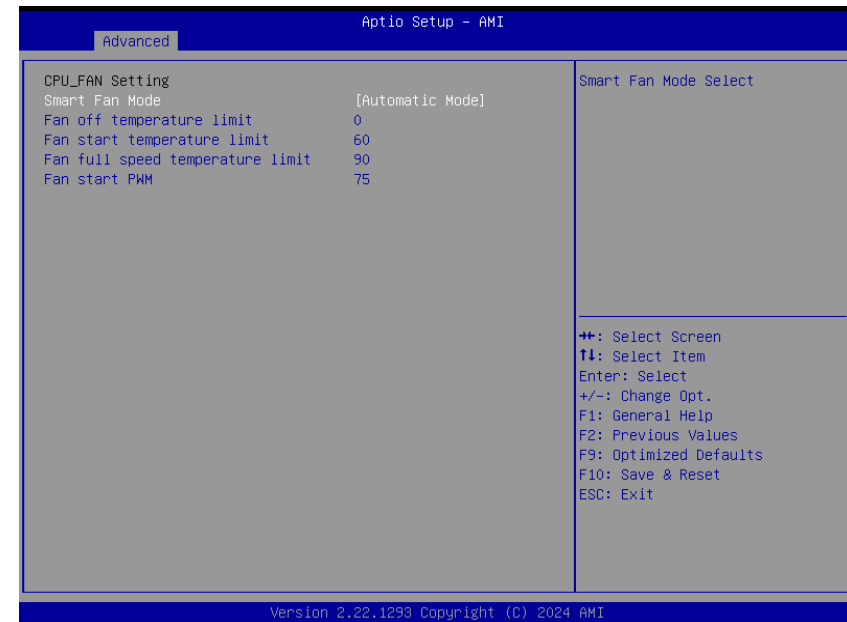

Smart Fan is a fan speed moderation strategy dependent on the current system temperature. When the system temperature goes higher than the Boundary setting, the fan speed will be turned up to the setting of the Fan Speed Count that bears the same index as the Boundary field.

Smart FAN Mode

Smart Fan Mode Select.

Fan off temperature limit

Fan will off when temperature lower than this limit.

Fan start temperature limit

Fan will work when temperature higher than this limit.

Fan full speed temperature limit

Fan will full speed when temperature higher than this limit.

Fan start PWM

Fan will start with this PWM value.

▶ Advanced

Serial Port Console Redirection

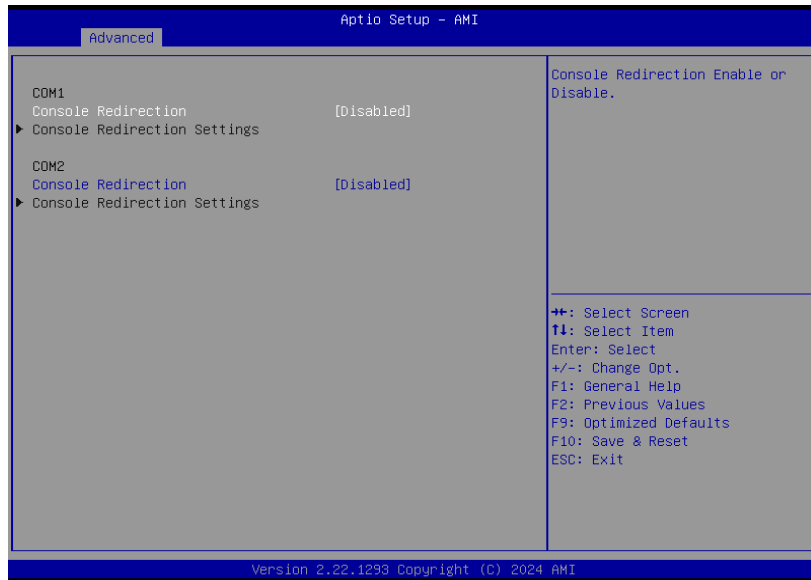

Console Redirection

By enabling Console Redirection of a COM port, the sub-menu of console redirection settings will become available for configuration as detailed in the following.

▶ Advanced

Serial Port Console Redirection ▶ Console Redirection Settings

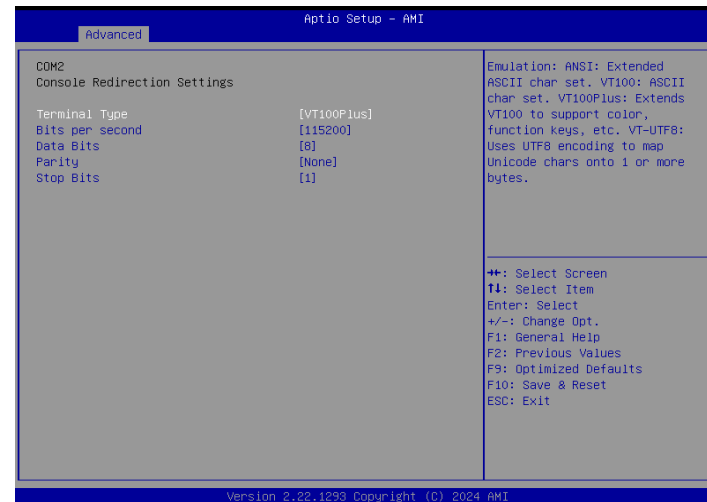
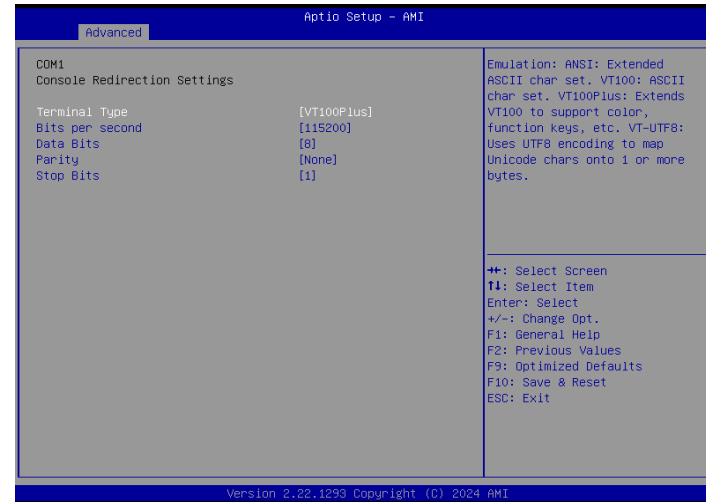

Configure the serial settings of the current COM port.

Terminal Type

Select terminal type: VT100, VT100+, VT-UTF8 or ANSI.

Bits per second

Select serial port transmission speed: 9600, 19200, 38400, 57600 or 115200.

Data Bits

Select data bits: 7 bits or 8 bits.

Parity

Select parity bits: None, Even, Odd, Mark or Space.

Stop Bits

Select stop bits: 1 bit or 2 bits.

▶ Advanced

ACPI Settings



Wake system from S5 via RTC

When Enabled, the system will automatically power up at a designated time every day. Once it's switched to [Enabled], please set up the time of day – hour, minute, and second – for the system to wake up.

State After G3

Select between S0 State, and S5 State. This field is used to specify what state the system is set to return to when power is re-applied after a power failure (G3 state).

- **S0 State** The system automatically powers on after power failure.
- **S5 State** The system enter soft-off state after power failure. Power-on signal input is required to power up the system.
- **Last State** The system returns to the last state right before power failure.

► Advanced

Network Stack Configuration

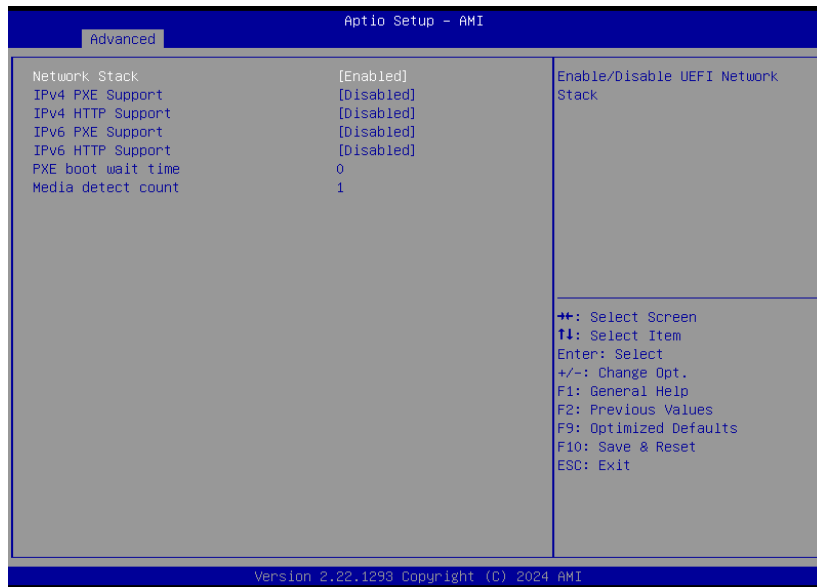

Network Stack

Enable or disable UEFI network stack. The following fields will appear when this field is enabled.

IPv4 PXE/HTTP Support

Enable or disable IPv4 PXE/HTTP boot support. If disabled, IPv4 PXE/HTTP boot support will not be available.

IPv6 PXE/HTTP Support

Enable or disable IPv6 PXE/HTTP boot support. If disabled, IPv6 PXE/HTTP boot support will not be available.

PXE boot wait time

Set the wait time in seconds to press ESC key to abort the PXE boot. Use either +/- or numeric keys to set the value.

Media detect count

Set the number of times the presence of media will be checked. Use either +/- or numeric keys to set the value.

► Advanced

DFI WDT Configuration

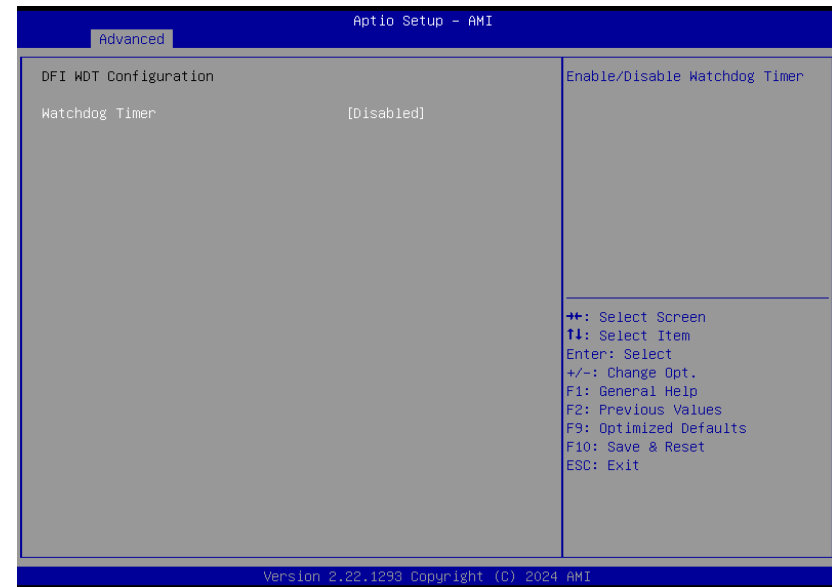

Watchdog Timer

Enable or disable Watchdog Timer.

► Advanced

USB Power Control

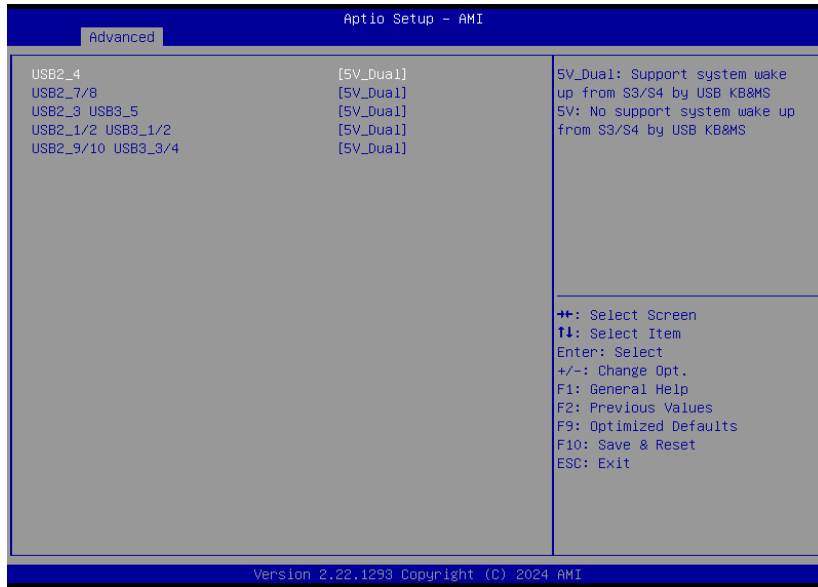

USB Power Switch

5_Dual: Support system wake up from S3/S4 by USB KB&MS

5V: No support system wake up from S3/S4 by USB KB&MS

► Security

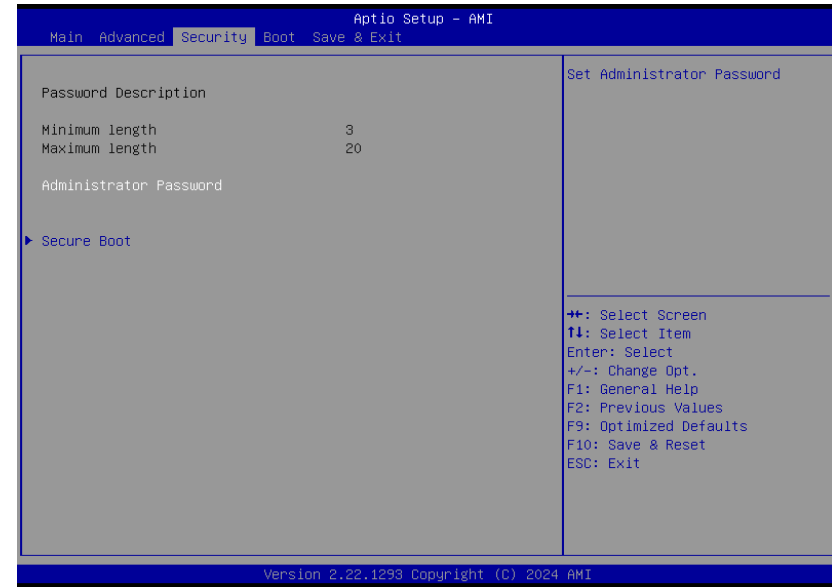

Administrator Password

Set the administrator password. To clear the password, input nothing and press enter when a new password is asked. Administrator Password will be required when entering the BIOS.

► Security

Secure Boot



Secure Boot

The Secure Boot store a database of certificates in the firmware and only allows the OSes with authorized signatures to boot on the system. To activate Secure Boot, please make sure that “Secure Boot” is “[Enabled]”, Platform Key (PK) is enrolled, “System Mode” is “User”, and CSM is disabled. After enabling/disabling Secure Boot, please save the configuration and restart the system. When configured and activated correctly, the Secure Boot status will be “Active”.

Secure Boot Mode

Select the secure boot mode – Standard or Custom. When set to Custom, the following fields will be configurable for the user to manually modify the key database.

Restore Factory Keys

Force system to User Mode. Load OEM-defined factory defaults of keys and databases onto the Secure Boot. Press Enter and a prompt will show up for you to confirm.

Reset To Setup Mode

Clear the database from the NVRAM, including all the keys and signatures installed in the Key Management menu. Press Enter and a prompt will show up for you to confirm.

Expert Key Management

Enables expert users to modify Secure Boot Policy variables without full authentication.

► Boot

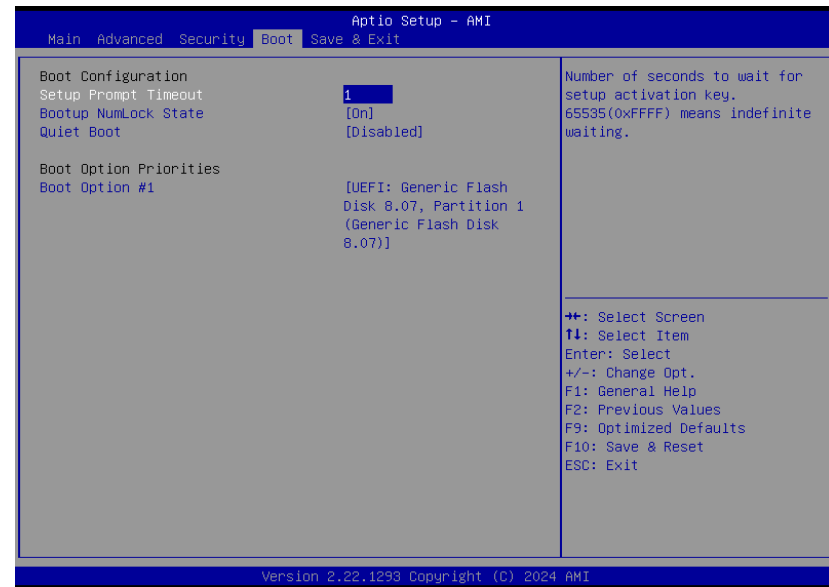

Setup Prompt Timeout

Set the number of seconds to wait for the setup activation key. 65535 (0xFFFF) denotes indefinite waiting.

Bootup NumLock State

Select the keyboard NumLock state: On or Off.

Quiet Boot

This section is used to enable or disable quiet boot option.

Boot Option Priorities

Rearrange the system boot order of available boot devices.

► Save & Exit

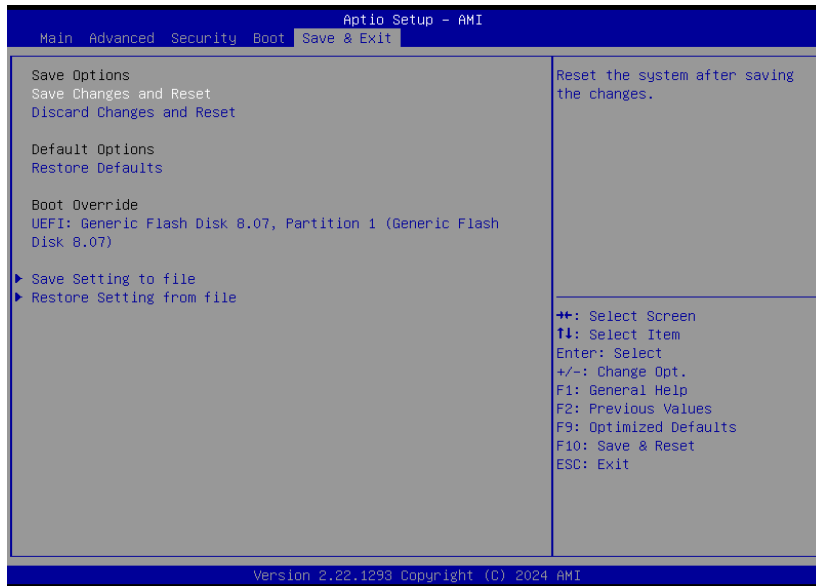

Save Changes and Reset

To save the changes, select this field and then press <Enter>. A dialog box will appear. Select Yes to reset the system after saving all changes made.

Discard Changes and Reset

To discard the changes, select this field and then press <Enter>. A dialog box will appear. Select Yes to reset the system setup without saving any changes.

Restore Defaults

To restore and load the optimized default values, select this field and then press <Enter>. A dialog box will appear. Select Yes to restore the default values of all the setup options.

Boot Override

Move the cursor to an available boot device and press Enter, and then the system will immediately boot from the selected boot device. The Boot Override function will only be effective for the current boot. The “Boot Option Priorities” configured in the Boot menu will not be changed.

- **Save Setting to file** Select this option to save BIOS configuration settings to a USB flash device.
- **Restore Setting from file** This field will appear only when a USB flash device is detected. Select this field to restore setting from the USB flash device.

► Updating the BIOS

To update the BIOS, you will need the new BIOS file and a flash utility. Please contact technical support or your sales representative for the files and specific instructions about how to update BIOS with the flash utility.

► Notice: BIOS SPI ROM

1. The Intel® Management Engine has already been integrated into this system board. Due to the safety concerns, the BIOS (SPI ROM) chip cannot be removed from this system board and used on another system board of the same model.
2. The BIOS (SPI ROM) on this system board must be the original equipment from the factory and cannot be used to replace one which has been utilized on other system boards.
3. If you do not follow the methods above, the Intel® Management Engine will not be updated and will cease to be effective.



Note:

- a. You can take advantage of flash tools to update the default configuration of the BIOS (SPI ROM) to the latest version anytime.
- b. When the BIOS IC needs to be replaced, you have to populate it properly onto the system board after the EEPROM programmer has been burned and follow the technical person's instructions to confirm that the MAC address should be burned or not.
- c. After updating unique MAC Address from manufacturing, NVM will be protected immediately after power cycle. Users cannot update NVM or MAC address.

Chapter 4 - Mating Connectors List

Please refer to the following list of the mating connectors.

Function	Location	Connector information	Rate output (Voltage, Ampere)
Audio	AUCN1	JST, BM08B-SRSS-TB1(LF)(SN), 1*8P, 1.0mm, BOX HEADER	NA
DIO	CN12	JST, BM10B-SRSS-TB1(LF)(SN), 1*10P, 1.0mm, BOX HEADER	5V, 1.1A
Front Panel	J2	V-STAR, SHY-JCL180806P, 2*3, 1.27mm, PIN PLUG	3V, 1A
USB 2.0	UBCN4	JST, BM08B-SRSS-TB1(LF)(SN), 1*8P, 1.0mm, BOX HEADER	5V, 0.5A/port
LVDS	DPCN1	PINREX, 712-76-40GWE0, 2*20P, 1.25mm, WTB HEADER	INV_PWR: 5V or 12V(default), 1.5A VCC_PANEL: 12V/5V/3.3V(default), 0.8A LVDS_3V3: 3.3V, 0.8A
COM1, COM2, COM3, COM4	TSCN1, TSCN4, TSCN11, TSCN2	PINREX, 710-93-095WR00B, 1*9P, 1.0mm, BOX HEADER	NA
I2C	CN6	JST, BM05B-SRSS-TB1(LF)(SN), 1*5P, 1.00mm, BOX HEADER	3.3V, 1A
System Fan	CN13	ACES, 50273-00371-001, 1*3P, 1.25mm, WAFER	12V, 0.6A