

User Manual

POC-621-12 Series (DC-In Model)

21.5" Computer with
11th Generation Intel®
Processor

ADVANTECH

Enabling an Intelligent Planet

Instructions for the User

The document combines text and illustrations, providing a comprehensive overview of the system. The information is presented as sequential action steps, allowing the user to learn directly how to use the device.

The text provides explanations and instructs the user step-by-step in the practical use of the product, with short, clear instructions in an easy-to-follow sequence.

Definitions

Warning! A **WARNING** statement provides important information about a potentially hazardous situation which, if not avoided, could result in death or serious injury.



Avertissement! Un **AVERTISSEMENT** fournit d'importantes informations concernant une situation potentiellement dangereuse qui, si elle n'est pas évitée, pourrait entraîner la mort ou des blessures graves.



Caution! A **CAUTION** statement provides important information about a potentially hazardous situation which, if not avoided, may result in minor or moderate injury to the user or patient or in damage to the equipment or other property.



Attention! Une **ATTENTION** fournit d'importantes informations concernant une situation potentiellement dangereuse qui, si elle n'est pas évitée, pourrait entraîner des blessures mineures ou modérées à l'utilisateur ou au patient et endommager l'équipement ou d'autres propriétés.



Note! A **NOTE** provides additional information intended to avoid inconveniences during operation.



Safety Instructions

1. Strictly follow these Instructions for use. Please read these safety instructions carefully.
2. Please keep this user manual for later reference. Any use of the product requires full understanding and strict observation of all portions of these instructions. Observe all WARNINGS and CAUTIONS as rendered throughout this manual and on labels on the equipment.
3. Repair of the device may also only be carried out by trained service personnel. Advantech recommends that a service contract be obtained with Advantech Service and that all repairs also be carried out by them. Otherwise the correct functioning of the device may be compromised.

Warning! *Because of the danger of electric shock, never remove the cover of a device while it is in operation or connected to a power outlet.*



4. If one of the following situations arises, get the equipment checked by service personnel:
 - The power cord or plug is damaged.
 - Liquid has penetrated into the equipment.
 - The equipment has been exposed to moisture.
 - The equipment does not work well, or you cannot get it to work according to the users manual.
 - The equipment has been dropped and damaged.
 - The equipment has obvious signs of breakage.
5. Disconnect this equipment from any AC outlet before cleaning. Use a damp cloth. Do not use liquid or spray detergents for cleaning and keep this equipment away from humidity.

Caution! *To avoid short-circuiting and otherwise damaging the device, do not allow fluids to come in contact with the device. If fluids are accidentally spilled on the equipment, remove the affected unit from service as soon as possible and contact the service personnel to verify that patient safety is not compromised.*



6. Put this equipment on a reliable surface during installation. Dropping it or letting it fall may cause damage. For plug-in equipment, the power outlet socket must be located near the equipment and must be easily accessible.

Caution! *To prevent overheating, do not cover the openings and place the device in direct sunlight or near radiant heaters.*



7. Make sure the voltage of the power source is correct before connecting the equipment to the power outlet. Position the power cord so that people cannot step on it. Do not place anything over the power cord. If the equipment is not used for a long time, disconnect it from the power source to avoid damage by transient over-voltage.

Caution! *Do not leave this equipment in an uncontrolled environment where the storage temperature is below 0°C (0°F) or above 50°C (122°F). This may damage the equipment.*



8. If your computer is losing dramatic time or the BIOS configuration resets to the default, the battery has no power.

Caution! *Do not replace the battery yourself. Please contact a qualified technician or your retailer.*



The computer is provided with a battery- powered, real-time clock circuit. There is a danger of explosion if the battery is incorrectly replaced. Replace only with BR2032 or an equivalent type recommended by the manufacturer.

Discard used batteries according to the manufacturer's instructions.

Caution! *The battery charging indicator is not included with this device. It will be added to the finished system assembly and be shown with the completed system.*



9. Improper installation of VESA mounting can result in serious personal injury! VESA mount installation should be done by a professional technician. Please contact the service technician or your retailer if you need this service. The detailed operating procedure is specified in Chapter4.
10. CLASSIFICATION:
 - 1). Class I internally powered
 - 2). No applied parts
 - 3). Continuous operation
 - 4). Not in the AP or APG category

Warning! *This device is not suitable for use in the presence of flammable anesthetic mixtures with air, oxygen, nitrous oxide, or for a life-support system.*



11. Environmental protection: follow national requirements to dispose of the unit.
12. Maintenance: to properly maintain and clean the surfaces, use only approved products or clean with a dry applicator.

Caution! *When servicing the device, always use replacement parts that are qualified to Advantech standards. Advantech Medical cannot warrant or endorse the safe performance of third-party replacement parts for use with our medical device.*



13. Make sure the user does not contact SIP/SOPs and the patient at the same time.

14. When networking with electrical devices, the operator is responsible for ensuring that the resulting system meets the requirements set forth by the following standards:
 - EN 60601-1 (IEC 60601-1) Medical electrical equipment
Part 1: General requirements for safety
 - EN 60601-1 (IEC 60601-1) Medical electrical equipment
Part 1-1: General requirements for safety
Collateral standard: Safety requirements for Medical electrical systems
 - EN 60601-1-2 (IEC 60601-1-2) Medical electrical equipment
Part 1-2: General requirements for safety
Collateral standard: Electromagnetic compatibility; requirements and tests
15. Accessory equipment connected to analog and digital interfaces must be in compliance with the respective nationally harmonized IEC standards (i.e. IEC 60950 for data processing equipment, IEC 60065 for video equipment, IEC 61010-1 for laboratory equipment, and IEC 60601-1 for medical equipment.)



MEDICAL – GENERAL MEDICAL EQUIPMENT
AS TO ELECTRICAL SHOCK, FIRE AND
MECHANICAL HAZARDS ONLY IN ACCORDANCE WITH
ANSI/AAMI ES60601-1:2005/(R)2012 and A1:2012/(R)2012
and A2:2021, CAN/CSA-C22.2 No. 60601-1 (Amendment
2:2022 (MOD) to CAN/CSA-C22.2 No. 60601-1:14)

Furthermore, all configurations shall comply with the system standard IEC 60601-1. Anyone who connects additional equipment to the signal input part or signal output part is configuring a medical system, and is therefore responsible that the system complies with the requirements of the system standard IEC 60601-1. The unit is for exclusive interconnection with IEC 60601-1 certified equipment in the patient environment and IEC 60XXX certified equipment outside of the patient environment. If in doubt, consult the technical services department or your local representative.

Caution! *Use a suitable mounting apparatus to avoid risk of injury. It shall be mounted by trained and authorized personnel on adequate allowances for quality of materials used to make the connection.*



16. Grounding reliability can only be achieved when the equipment is connected to an equivalent receptacle marked "Hospital Only" or "Hospital Grade".
17. Use a power cord that matches the voltage of the power outlet, which has been approved and complies with the safety standard of your particular country.

Note! *Environmental protection*



Follow national requirements to dispose of the unit.

18. **WARNING** - Do not modify this equipment without authorization of the manufacturer.
19. **WARNING** - To avoid risk of electric shock, this equipment must only be connected to a supply mains with protective earth.
20. Remove the power cord to fully turn off the device.
21. Only use a power cord with following specification: 18AWG min., type SJT, UL/CSA listed, length: 1.8m, hospital grade if for USA/Canada market.

22. Installation is only to be carried out by trained personnel authorized by the manufacturer.
23. The device is intended to be used as SIP/SOP, facing downward.

Instructions pour l'utilisateur

Le document combine du texte et des illustrations, offrant un aperçu complet du système. Les informations sont présentées sous forme d'actions séquentielles, permettant à l'utilisateur d'apprendre directement à utiliser le périphérique.

Le texte fournit des explications et informe l'utilisateur, étape par étape, de l'utilisation pratique du produit, avec des instructions courtes et claires, dans une séquence facile à suivre.

Définitions

AVERTISSEMENT! Une déclaration **AVERTISSEMENT** fournit des informations importantes sur une situation potentiellement dangereuse qui, si elle n'est pas évitée, pourrait entraîner la mort ou des blessures graves.



ATTENTION! Une déclaration **CAUTION** fournit des informations importantes sur une situation potentiellement dangereuse qui, si elle n'est pas évitée, peut entraîner des blessures mineures ou modérées à l'utilisateur ou au patient ou des dommages à l'équipement ou à d'autres biens.



AVERTISSEMENT! Une **REMARQUE** fournit des informations supplémentaires destinées à éviter les inconvénients en cours de fonctionnement.



Consignes de Sécurité

1. Suivez minutieusement ces instructions d'utilisation. Veuillez lire attentivement les consignes de sécurité.
2. Veuillez conserver ce guide d'utilisation pour référence ultérieure. Toute utilisation de ce produit requiert une profonde connaissance et le respect intégral de toutes les sections de ces instructions. Respectez toutes les consignes d'AVERTISSEMENT et de MISE EN GARDE comme indiqué à travers le présent guide et sur les étiquettes affichées sur l'appareil.
3. La réparation de l'appareil ne doit être effectuée que par du personnel de service qualifié. Advantech recommande qu'un contrat de service soit conclu avec le service de maintenance Advantech et que toutes les réparations soient également effectuées par ce dernier. Sinon, le bon fonctionnement de l'appareil pourrait être compromis.

Avertissement! *En raison du danger de choc électrique, ne retirez jamais le couvercle d'un appareil en cours de fonctionnement ou sur une prise secteur.*



4. Si l'une des situations suivantes se produit, faites vérifier l'équipement par le personnel de service:
 - Le cordon d'alimentation ou la fiche est endommagé.
 - Un liquide a pénétré dans l'appareil.
 - L'équipement a été exposé à l'humidité.
 - L'équipement ne fonctionne pas bien ou vous ne pouvez pas le faire fonctionner conformément au manuel d'utilisation.
 - L'équipement est tombé et a été endommagé.
 - L'équipement présente des signes évidents de rupture.
5. Débranchez cet appareil de toute prise secteur avant le nettoyage. Utilisez un chiffon humide. N'utilisez pas de détergents liquides ou en aérosol pour le nettoyage et conservez cet équipement à l'abri de l'humidité.

Attention! *Pour éviter tout court-circuit ou tout autre dommage pour l'appareil, évitez tout contact des liquides avec celui-ci. En cas de déversement accidentel de liquides sur l'équipement, retirez dès que possible l'unité concernée du service et contactez le personnel de maintenance pour vérifier que la sécurité du patient n'est pas compromise.*



6. Placez cet équipement sur une surface solide pendant l'installation. La chute de l'appareil peut l'endommager. Pour les équipements branchés, la prise d'alimentation doit être près de l'appareil et doit être facilement accessible.

Attention! *Pour éviter toute surchauffe, ne couvrez pas les ouvertures et ne placez pas l'appareil à la lumière directe du soleil ou à proximité de radiateurs.*



7. Assurez-vous que la tension de la source d'alimentation est correcte avant de connecter l'équipement à la prise de courant. Placez le cordon d'alimentation de sorte que personne ne puisse marcher dessus. Ne placez rien sur le cordon d'alimentation. Si l'appareil n'est pas utilisé pendant une longue période,

débranchez-le de la source d'alimentation pour éviter tout dommage dû à une surtension transitoire.

Attention! *Ne laissez pas cet équipement dans un environnement non contrôlé où la température de stockage est inférieure à -0° C ou supérieure à 50° C. Cela pourrait l'endommager.*



8. Si votre ordinateur ne conserve pas l'heure exacte ou si la configuration du BIOS a été réinitialisée, la batterie peut ne pas avoir de charge.

Attention! *L'ordinateur est équipé d'un circuit d'horloge temps réel alimenté par batterie. Il y a un risque d'explosion si la batterie est remplacée de manière incorrecte. Remplacez uniquement avec le même type recommandé par le fabricant.*



Jetez les piles usagées conformément aux instructions du fabricant.

Attention! *L'indicateur de charge de la batterie n'est pas inclus avec cet appareil. Il sera ajouté à l'assemblage du système fini et sera affiché avec le système terminé.*



9. Une installation incorrecte du montage VESA peut entraîner des blessures graves! L'installation du support VESA doit être effectuée par un technicien professionnel. Veuillez contacter le technicien de maintenance ou votre revendeur si vous avez besoin de ce service. La procédure d'utilisation détaillée est spécifiée à l'annexe A.
10. Classification:
- 1). Adaptateur secteur classe 1
 - 2) Aucune partie appliquée
 - 3) Opération continue
 - 4) Pas de catégorie AP ou APG

Avertissement! *Ce dispositif ne convient pas pour une utilisation en présence d'un mélange anesthésique inflammable avec de l'air, de l'oxygène, de l'oxyde nitreux ou pour des systèmes de survie.*



11. Protection de l'environnement: respecter les exigences nationales en matière d'élimination de l'appareil.
12. Entretien: pour bien entretenir et nettoyer les surfaces, utilisez uniquement les produits approuvés ou nettoyez-les avec un applicateur sec.

Attention! *Lors de l'entretien de l'appareil, utilisez toujours des pièces de rechange conformes aux normes Advantech. Advantech Digital Healthcare ne peut en aucun cas garantir ou garantir la sécurité des pièces de rechange tierces à utiliser avec notre dispositif médical.*



13. Assurez-vous que l'utilisateur n'autorise pas le contact simultané entre SIP / SOP et le patient.
14. Lors de la mise en réseau d'appareils électriques, il incombe à l'opérateur de s'assurer que le système résultant répond aux exigences définies par les normes suivantes:

- EN 60601-1 (IEC 60601-1) Appareils électromédicaux
Partie 1: Prescriptions générales pour la sécurité
 - EN 60601-1 (IEC 60601-1) Appareils électromédicaux
Partie 1-1: Exigences générales pour la sécurité
Norme collatérale: exigences de sécurité pour les systèmes électriques médicaux
 - EN 60601-1-2 (IEC 60601-1-2) Appareils électromédicaux
Partie 1-2: Exigences générales pour la sécurité
Norme collatérale: compatibilité électromagnétique; Conditions et tests
15. Les équipements accessoires connectés aux interfaces analogiques et numériques doivent être conformes aux normes CEI harmonisées au niveau national (CEI 60950 pour les équipements de traitement de données, CEI 60065 pour les équipements vidéo, CEI 61010-1 pour les équipements de laboratoire et CEI 60601-1 pour équipement médical.)
De plus, toutes les configurations doivent être conformes à la norme système CEI 60601-1. Quiconque connecte un équipement supplémentaire à la partie d'entrée de signal ou à la partie de sortie de signal configure un système médical et est donc responsable de la conformité du système aux exigences de la norme système CEI 60601-1. L'unité est destinée à une interconnexion exclusive avec un équipement certifié CEI 60601-1 dans l'environnement du patient et un équipement certifié CEI 60XXX en dehors de l'environnement du patient.
En cas de doute, consultez le service technique ou votre représentant local.

Attention! *Utilisez un appareil de montage approprié pour éviter tout risque de blessure, il doit être monté par un personnel formé et autorisé sur des tolérances adéquates pour la qualité des matériaux utilisés pour effectuer la connexion.*



16. La fiabilité de la mise en terre ne peut être garantie que si l'équipement est branché à une prise certifiée « Hôpital uniquement » ou « Grade-hôpital ».
17. Utilisez un cordon d'alimentation homologué de calibre correspondant à la tension du secteur et qui est conforme aux normes de sécurité propres à votre pays.
"Protection de l'environnement
Suivez les exigences nationales en matière de l'élimination de cet appareil."
18. **AVERTISSEMENT** – Ne modifiez pas cet équipement sans l'autorisation du fabricant.
19. **AVERTISSEMENT** – Afin d'éviter le risque de décharges électriques, cet équipement doit être branché à une prise d'alimentation équipée d'une mise à terre.
20. Retirez le cordon d'alimentation pour éteindre l'appareil.
21. Utilisez uniquement le cordon d'alimentation fourni avec le produit, en cas de doute, veuillez contacter Advantech pour plus d'informations.
22. L'installation ne doit être effectuée que par le personnel autorisé et formé du fabricant.
23. L'appareil est destiné à être utilisé comme SIP / SOP orienté vers le bas.

Explanation of Graphical Symbols



IEC 60878 and ISO 3864-B.3.6: Warning: dangerous voltage



ISO 7000-0434: Caution, consult ACCOMPANYING DOCUMENTS.



ISO 7000-1641: Follow operating instructions or consult instructions for use.



IEC 60417 -5009: STAND-BY



IEC 60417-5032: Alternating Current



IEC 60417-5031: Direct Current



IEC 60417-5021: Equipotentiality



ISO 7010-M002: Follow instructions for use.

Disposing of your old product

Within the European Union



EU-wide legislation, as implemented in each Member State, requires that waste electrical and electronic products carrying the mark (left) must be disposed of separately from normal household waste. This includes monitors and electrical accessories, such as signal cables or power cords. When you need to dispose of your display products, please follow the guidance of your local authority, or ask the shop where you purchased the product, or if applicable, follow any agreements made.

The mark on electrical and electronic products only applies to the current European Union Member States.

FCC Class B

This equipment has been tested and found to comply with the limits for a Class B digital device, pursuant to Part 15 of the FCC Rules.

These limits are designed to provide reasonable protection against harmful interference when the equipment is operated in a residential environment. This equipment generates, uses and can radiate radio frequency energy. If not installed and used in accordance with this users manual, it may cause harmful interference to radio communications.

Note that even when this equipment is installed and used in accordance with this user's manual, there is still no guarantee that interference will not occur. If this equipment is believed to be causing harmful interference to radio or television reception, this can be determined by turning the equipment on and off. If interference is occurring, the user is encouraged to try to correct the interference by one or more of the following measures:

- Reorient or relocate the receiving antenna.
- Increase the separation between the equipment and the receiver.
- Connect the equipment to a power outlet on a circuit different from that to which the receiver is connected.
- Consult the dealer or an experienced radio/TV technician for help.

Warning! *Any changes or modifications made to the equipment which are not expressly approved by the relevant standards authority could void your authority to operate the equipment.*



Warning! *This device complies with Part 15 of the FCC Rules. Operation is subject to the following two conditions:*



- (1) *this device may not cause harmful interference, and*
- (2) *this device must accept any interference received, including interference that may cause undesired operation.*

Avertissement! *Toute modification apportée à l'équipement sans l'approbation explicite de l'autorité de normalisation compétente pourrait annuler votre droit à utiliser l'équipement.*



List of Accessories

Before installing your Point-of-Care terminal, ensure that the following materials have been received:

- POC-621-12 SERIES Point-of-Care terminal
- Mounting kits and packet of screws.
- VESA mounting note x1
- China RoHs note x1

Warning! *There are no user-serviceable parts inside. Refer servicing to qualified personnel. Only the accessories indicated on the list of accessories above have been tested and approved to be used with the device. Accordingly, it is strongly recommended that only these accessories be used in conjunction with the specific device. Otherwise the correct functioning of the device may be compromised.*



Avertissement! *Aucune pièce réparable par l'utilisateur. Pour l'entretien, adressez-vous à des personnes qualifiées. Seuls les accessoires décrits dans la liste ci-dessus ont été vérifiés et approuvés pour être utilisés avec cet appareil. Conséquemment, il est fortement recommandé d'utiliser ces accessoires spécifiquement avec cet appareil. Autrement, le fonctionnement adéquat de l'appareil serait compromis.*



Additional Information and Assistance

Contact your distributor, sales representative, or Advantech's customer service center for technical support if you need additional assistance. Please have the following information ready before you call:

- Product name and serial number
- Description of your peripheral attachments
- Description of your software (operating system, version, application software, etc.)
- A complete description of the problem
- The exact wording of any error messages
- This equipment is a source of electromagnetic waves. Before using, please make sure that there are no EMI sensitive devices in its surrounding which could malfunction.

Environmental protection

- Follow national requirements to dispose of the unit.

Manufacturer

Advantech Co., Ltd.

No.1, Alley 20, Lane 26, Ruiguang Road Neihu District, Taipei,
Taiwan 114, R.O.C.

TEL: (02) 2792-7818

Distributed in Europe by:

Advantech Europe Service Center

Science Park Eindhoven 5708

5692 ER Son en Breugel

The Netherlands

Phone: +31 (0)76 523 3100

Email: iHealthcare.SalesSupport@advantech.nl

URL: <http://www.advantech.eu>

Visit the Advantech websites at www.advantech.com or www.advantech.com.tw if you need more information.

Contents

Chapter 1	General Information	1
1.1	Introduction	2
1.2	Specifications	2
	Table 1.1: Specifications	2
1.3	Dimensions	4
	Figure 1.1 Dimensions of the POC-621-12 Series	4
	Figure 1.2 Dimensions of the POC-621-12 Series with Smart Card Reader	4
	Figure 1.3 Dimensions of the POC-621-12 Series with RFID & Camera	5
	Figure 1.4 VESA Mounting of the POC-621-12 Series	5
	Figure 1.5 POC-621-12 Series Front Panel	6
1.4	Optional Modules	6
	1.4.1 Cleaning and Disinfecting	6
1.5	Operating Principle	7
1.6	Intended User Profile	7
Chapter 2	System Setup	9
2.1	A Quick Tour of the POC-621-12 Series	10
	2.1.1 Front View	10
	Figure 2.1 Front View of the Point-of-Care Terminal	10
	2.1.2 Rear View	10
	Figure 2.2 Rear View of the Point-of-Care Terminal	10
	Figure 2.3 Rear View of Multiple I/O Ports (AC-In Model)	11
2.2	Installation Procedures	11
	2.2.1 Connecting the Power Cord	11
	2.2.2 Connecting the DC-In	12
	2.2.3 Connecting the Ground Pin	13
	Figure 2.4 POC-621-12 Series Equipotential Terminal Pin	13
	Figure 2.5 Grounding Cable with Connector	13
2.3	Running the BIOS Setup Program	13
2.4	Installing System Software	14
2.5	Installing the Drivers	14
2.6	Troubleshooting	15
	2.6.1 POC not powering on	15
	2.6.2 Adapter power LED is off	15
	2.6.3 The POC system powers on but does not boot to Windows	15
	2.6.4 AC power is connected and all indicators are on, but the system doesn't power on	16
	2.6.5 No charge	16
2.7	EMC Declaration	16
Chapter 3	Operation and Safety	21
3.1	General Safety Guide	22
3.2	Thermal	22
3.3	Disconnect the Power	23
3.4	Proper Handling	24
3.5	Battery Warnings	24
3.6	Battery Safety Instructions	25
3.7	Emergency Scenarios	29
3.8	Battery Storage and Transportation	30
3.9	Battery Disposal	31

Chapter	4	VESA Mount Installation	33
	4.1	VESA Mount Installation	34
		Figure 4.1 VESA Mounting	34
Chapter	5	Driver Installation.....	35
	5.1	Driver Installation	36
Chapter	6	PCM-8725 Connector Map.....	37
	6.1	POC System with PCM-8725 PCBA.....	38
		Figure 6.1 Motherboard Top Side.....	38
		Figure 6.2 Motherboard Bottom Side	39
Chapter	7	PCM-8725 Jumper Settings.....	41
	7.1	PCM-8725 Jumper Settings.....	42
		Figure 7.1 Motherboard Top Side.....	42
	7.1.1	Jumper Settings:.....	42
		Table 7.1: CN6 ME Manufacturing Mode	43
		Table 7.2: CN5 Clear CMOS	43
		Table 7.3: CN8 System Reset (Reserved, Internal Test Only)..	43
		Table 7.4: CN13 LVDS Voltage Setup	43
		Table 7.5: CN40 Power Button (Reserved, Internal Test Only)	44
		Table 7.6: PCN4 Power Debug (Reserved, Internal Test Only)	44
		Table 7.7: SW1 Board Setup.....	44
		Table 7.8: SW1 Pin 4 Speaker Function	45
		Table 7.9: SW4 Panel Resolution/Type Setup	45
Chapter	8	Front Bezel Button.....	47
	8.1	Introduction	48
Chapter	9	Advanced BIOS Functions.....	49
	9.1	Advanced BIOS Functions.....	50
Chapter	10	Temporarily Disable VMD for OS Image Restoration	53
	10.1	Introduction	54
Chapter	11	Installing a PCIe Card	57
	11.1	Installing a PCIe Card	58
		11.1.1 Install PCIe(x4) Card	59
Chapter	12	Hot-Swap Battery Pack Operation...	61
	12.1	Installing the Hot-Swap Battery Pack.....	62
	12.2	Battery Pack Capacity Indicator	64
		Table 12.1: Capacity	65
		Table 12.2: Capacity	65
	12.3	Regular Use of a Battery Pack.....	66

12.4	Battery Pack Storage	66
12.5	Battery Operation Sequence	66

Chapter 1

General Information

1.1 Introduction

The POC-621-12 series is a multimedia Intel® Core™ i7, i5, i3, or Celeron™ processor device designed for mobile computing as a Point-of-Care terminal (POC.) It is a PC-based system with a 21.5" wide screen TFT LCD display, HDMI, and dual LAN. It has 1 x COM port, 4 x USB 3.2 Type-A ports, 1 x USB 3.2 Type-C, and a 24-bit stereo audio controller. With an optional 2.5" SSD, the POC-621-12 series is a user-friendly computer. For system integrators, this highly integrated multimedia system lets you easily build a Point-of-Care terminal into your applications. The POC-621-12 series makes it an ideal and safe point-of-care solution for patients and hospital practitioners. The POC-621-12 series is specially designed to resist spills and water damage, and ensures dust resistance with its protected LCD and sealed ports. The POC-621-12 series is a reliable solution for your application's processing requirements.

Intended use - The POC-621-12 series is intended to serve as a Point-of-Care terminal (POC) for integration with hospital systems. The POC-621-12 series is designed for general-purpose medical computing in a hospital environment, for data collection, and for displaying information. It should not be used as a life-support system.

The latest version of this user manual is available for download from <http://support.advantech.com.tw/support/>

1.2 Specifications

Table 1.1: Specifications

Computing System	CPU	Intel® Core™ i7-1185G7E (12M cache, up to 4.40 GHz) Intel® Core™ i5-1145G7E (8M cache, up to 4.10 GHz) For i3-1115G4E and Celeron 6305E Model, please contact Advantech for project.
	Memory	8GB DDR4 (supports up to 64GB DDR4 SODIMM)
	Graphics Controller	Intel® Iris® Xe Graphics
	Size	21.5 inch
Display	Type	10-point multi touch P-CAP (clear glass); optional AG/AR support upon request
	Max. Resolution	1920 x 1080 (H x V)
	Max. Colors	16.7 M colors (6-bits+A-FRC)
	Pixel Pitch (um)	247.5 x 247.5
	Viewing Angle	178/178°
	Luminance	250 cd/m2
	Backlight	LED
	LCD MTBF	30,000 Hours
Expansion Slots	Contrast Ratio	1000 : 1
	Mini PCIe	1 (full size)
	M.2 2230	1 (for Wi-Fi/Bluetooth module)
	PCIe x4**	1 (Max card length: 167.65 mm/6.6 in) Either PCIe x4 or backup battery can be chosen. Not both.

Table 1.1: Specifications		
I/O Ports	USB 3.2 Gen 2 (Type-A)	4
	USB 3.2 Gen 2 (Type-C)	1 (with display function)
	USB 2.0 Type-A	2
	HDMI	1
	LAN isolation, 1.5KV	2
	Mic-In/Headphone-Out	1/1
	COM (RS232) 1.5KV	2
Power Input	DC	19V, max. 150W
Certification	EMC & Safety	Medical CE, FCC (IEC 60601-1-2, 4th edition) EN 60601-1 Compliance UL 60601-1
Environment	Temperature	Operating: 0°C ~ +35°C, Transport/Storage: 0°C ~ 50°C
	Humidity	Operating: 10% ~ 90%@40°C non-condensed, Transport/Storage: 5% ~ 90%@40°C non-condensed
	Shock Resistance	20G peak acceleration (11ms duration)
	Pressure	700-1013 hPa (Operation) 70-106 kPa (Storage) 70-106 kPa (Transportation)
Physical Characteristics	Dimensions (W x D x H)	524 x 357 x 62 mm / 20.63 x 14.06 x 2.44 in
	Weight (Bare system)	6.29 kg / 13.86 lb
	VESA Mount	100 x 100, 75 x 75 mm
Optional Configuration	Operating System	Windows 10 IoT Ent (64-bit only), Linux (support by request)
	Memory	Up to 64GB DDR4 SODIMM
	Storage	NVME SSD 128G/ 256G/ 512GB PCIe interface or 128G/ 256G/ 512G/ 1TB / 2TB 2.5" SATA SSD available
	WLAN	Intel® Wi-Fi 6E AX210 or Intel Wireless-AC9260
	Bluetooth	5.3 / 5.1
	RFID	RFIDEAS KT-805N64KU (The Pico Integrated Card Reader is a dual-band card reader capable of reading both 125 kHz and 13.56 MHz credentials.) (choose either RFID or smart card reader)
	Smart Card Reader	Smart Card (choose either RFID or smart card reader)
	Backup Battery	One Internal Backup Battery, POC-IPSM90B (POC-BAT-101-6A), Lithium-ion 8400mAh 10.8V 90.72Wh 3S3P). Either PCIe x4 or backup battery can be chosen, but not both.
	Hot-Swapping Battery Module	Optional with 2 x batteries (choose either backup battery or hot-swap battery module), POC-IPSM90B2 (POC-BAT-201-62)
	Camera	5MP, Auto Focus
Touch Panel	21.5", clear glass, AR/AG (request by project)	

1.3 Dimensions

Dimensions: 523 x 356 x 62 mm (Unit: mm)

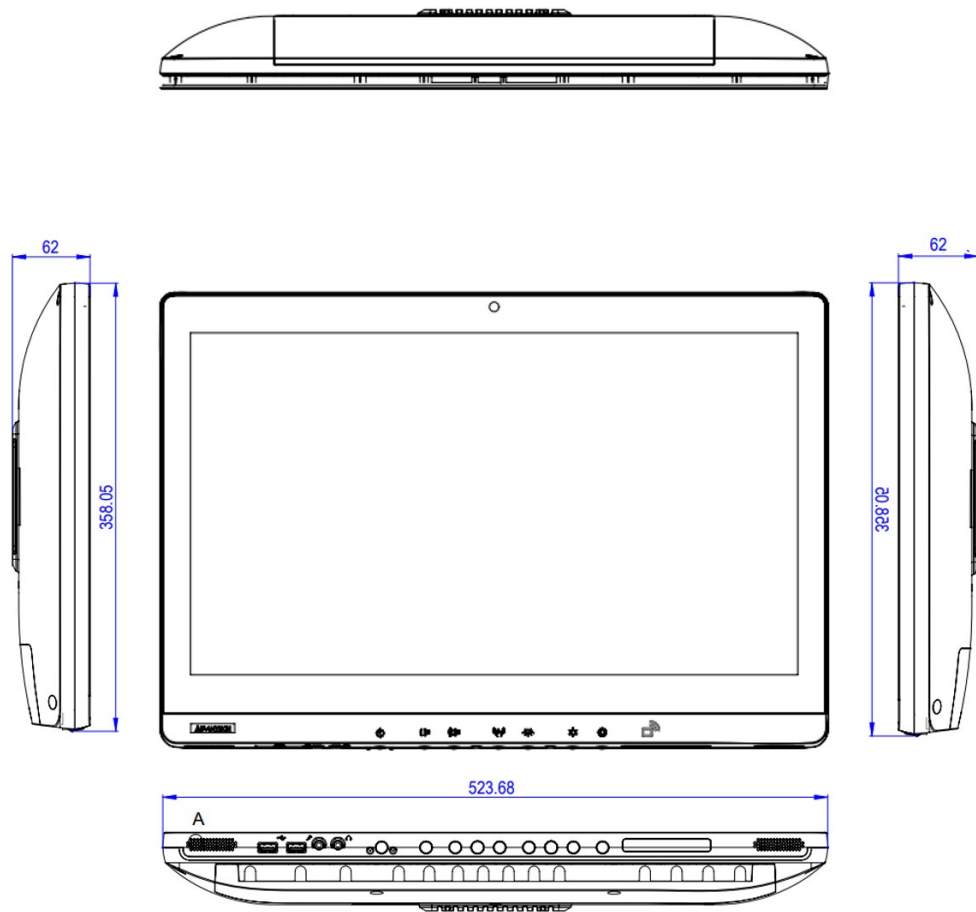

Figure 1.1 Dimensions of the POC-621-12 Series

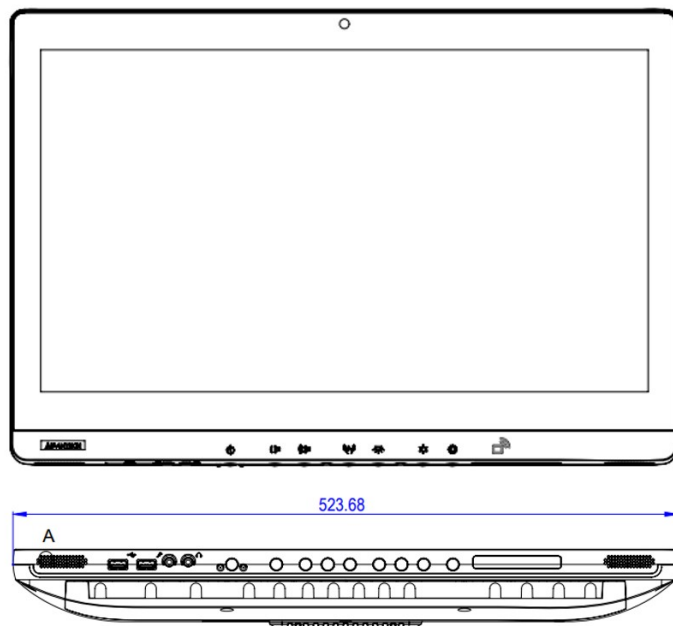

Figure 1.2 Dimensions of the POC-621-12 Series with Smart Card Reader

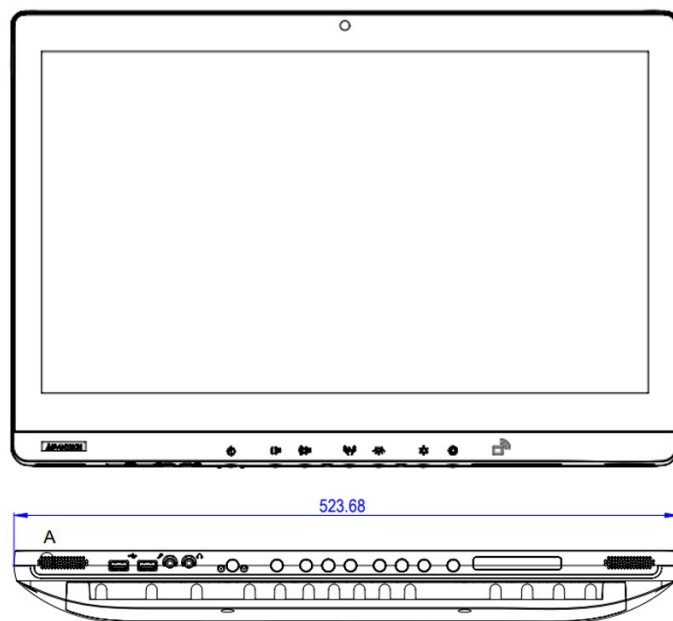

Figure 1.3 Dimensions of the POC-621-12 Series with RFID & Camera

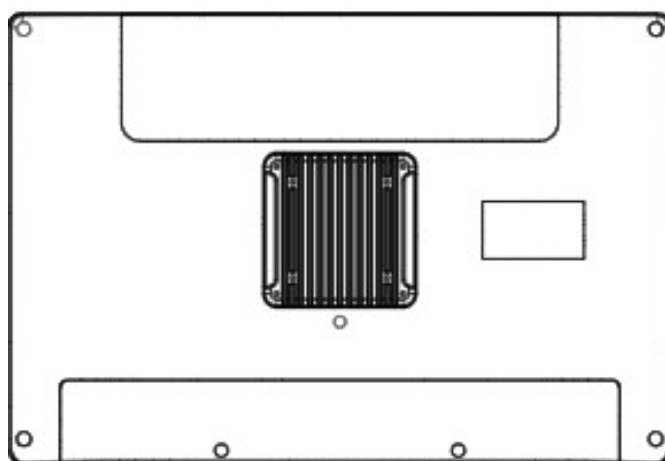

Figure 1.4 VESA Mounting of the POC-621-12 Series

VESA Mounting: 75 x 75 mm; 100 x 100 mm

Please use M4x12L (mm) screw.

Warning! *To prevent the risk of injury, utilize an appropriate mounting apparatus. Ensure that the mounting is performed by trained and authorized personnel, taking into account the use of high-quality materials for the installation.*



Avertissement! *Utilisez un appareil de montage approprié pour éviter tout risque de blessure, il doit être monté par un personnel formé et autorisé sur des tolérances adéquates pour la qualité des matériaux utilisés pour effectuer la connexion.*



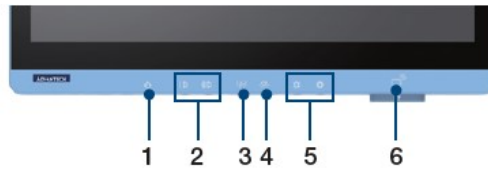

1. Power button
2. Volume down/up
3. Touchscreen status control
4. Read light control
5. Brightness down/up
6. RFID or smart card reader slot

Figure 1.5 POC-621-12 Series Front Panel

1.4 Optional Modules

- **Memory:** Up to 64GB DDR4 SODIMM
- **Primary Storage:** NVME (M2 2280, PCIe interface)
- **Wi-Fi and Bluetooth module:** Intel® Wi-Fi 6E AX210 and Intel Wireless-AC9260
- **RFID module:** RFIDEAS KT-805N64KU
- **Smart Card**
- **Backup battery:** One Internal Backup Battery, POC-IPSM90B, Lithium-ion 8400mAh 10.8V 90.72Wh 3S3P).
- **Camera:** 5MP Auto Focus
- **Touchscreen:** Projected Capacitive / Optional AR/ Optional AG Coating

The above optional modules might be mutually exclusive from each other. Contact Advantech for more details.

1.4.1 Cleaning and Disinfecting

During normal use of the POC (Point-of-Care Terminal), the device may become dirty and should be regularly cleaned.

Steps:

1. Prepare cleaning water.
2. Wipe the POC with a clean cloth that has been moistened in the cleaning solution.
3. Wipe thoroughly with a clean cloth.

Caution!



- *Do not immerse or rinse the POC or its peripherals. If you accidentally spill liquid on the device, disconnect the unit from the power source. Contact your IT support department regarding the continued safety of the unit before placing it back in operation.*
- *Do not spray cleaning agent on the chassis.*
- *Do not use disinfectants that contain phenol.*
- *Do not autoclave or clean the POC or its peripherals with strong aromatic, chlorinated solutions, ketone, ether, or ether solvents, sharp tools, or abrasives. Never immerse electrical connectors in water or other liquids.*

- Attention!** ■ *N'immergez pas et ne rincez pas le POC-621-12 ou ses périphériques. Si vous accidentellement renverser du liquide sur l'appareil, débranchez l'appareil de l'alimentation la source. Contactez votre service de support informatique concernant la suite sécurité de l'appareil avant de le remettre en service-Ne pas vaporisez un produit de nettoyage sur le châssis.*
- 
- *N'utilisez pas de désinfectants contenant du phénol.*
 - *N'autoclavez pas et ne nettoyez pas le POC-621-12 ou ses périphériques avec solvants aromatiques, chlorés, cétoniques ou éthers, outils tranchants ou abrasifs. Ne plongez jamais les connecteurs électriques dans l'eau ou autre liquides.*

1.5 Operating Principle

The device provides input through the touch panel, hard keys located at the bottom of the unit, accessories through USB ports, or its LAN/WLAN connections. The device computes the input data with its processing unit and then outputs the generated data to the LCD panel, accessories, or other devices through its I/O ports or through its LAN/WLAN connections. The device is able to store data in its storage, and when the device is turned off, maintains the data in the memory units of the storage.

1.6 Intended User Profile

Intended user profile:

- Age: 18 to 65
- Weight: not relevant
- Health: not relevant
- Nationality: global
- Patient state: patient will not be the operator.
- Part of the body or type of tissue applied to or interacted with: hands and fingers, expected contact time shall be less than 1 min.
- Education level: at least 8 years of intensive reading experience (school)
- Knowledge:
 - Minimum – read and understand “westernized Arabic” numerals when written in Arial font
 - can distinguish: every part of the body as described in the user manual
 - trained and authorized by the manufacturer only
- To be considered as trained and authorized, an individual must complete the training course of the manufacturer; see document number xxxxx for the qualification method. When considered necessary by the manufacturer, the technician shall be called back for retraining and annual training is also considered necessary.
- Language of understanding: English, and whenever other languages are required, a professional translation company shall translate and have the translation reviewed by the manufacturer; see SOP document number: XXXXX
- Experience: Mentally and physical competent with specific medical training to understand basic knowledge and symbols.
- Permissible impairments:
 - Mild reading vision impairment or vision corrected to log MAR 0,2 (6/10 or 20/32)

-
- One arm/hand system capable of guiding and holding the device
 - Average degree of aging-related short-term memory impairment
 - Hearing impairment by 40%, resulting in 60% of normal hearing at 500 Hz to 2 kHz

Chapter 2

System Setup

2.1 A Quick Tour of the POC-621-12 Series

Before you start to set up the POC-621-12 Series, take a moment to become familiar with the locations and purposes of the controls, drives, connections, and ports, which are illustrated in the figures below.

When you place the POC-621-12 series upright on the desktop, its front panel appears as shown in Figure 2.1.

2.1.1 Front View

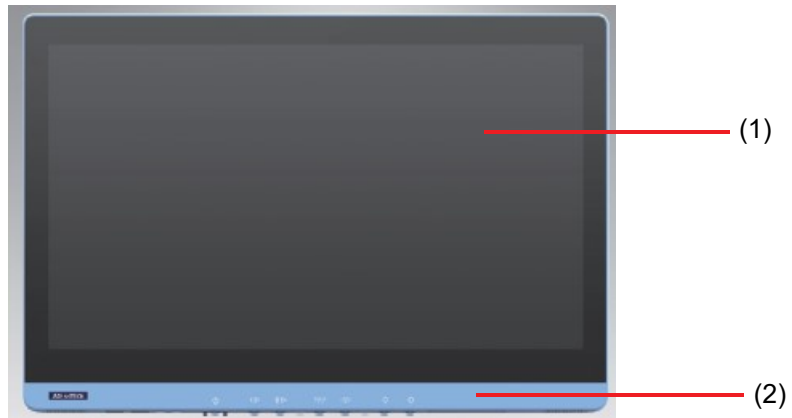

Figure 2.1 Front View of the Point-of-Care Terminal

Front Bezel view

- (1) LCD panel with touchscreen module
- (2) Power symbol w/ indicator light

2.1.2 Rear View

When you turn the Point-of-Care Terminal around and look at its rear cover, the sunken I/O section is at the bottom of the panel PC, as shown in Figure 2.2 with a zoomed-in rear view in Figure 2.3. (The I/O section includes various I/O ports, including serial ports, HDMI port, the Ethernet port, USB ports, and so on.)

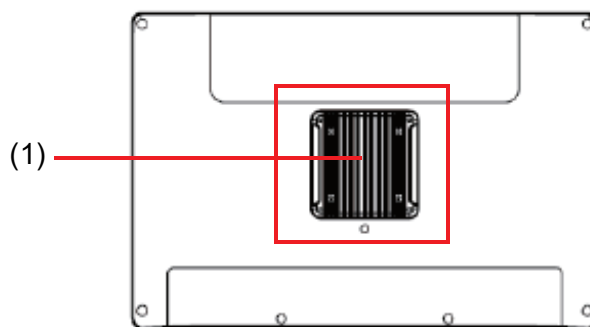
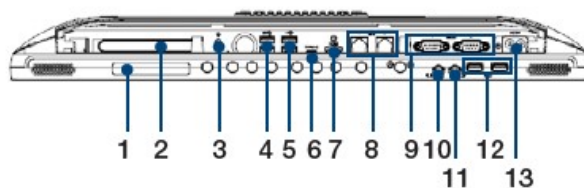

Figure 2.2 Rear View of the Point-of-Care Terminal



- | | | |
|-----------------------------------|-------------------------|-----------------|
| 1. RFID or smart card reader slot | 6. 1 x USB Type-C | 11. Mic-in |
| 2. PCIe x4 slot | 7. HDMI | 12. 2 x USB 2.0 |
| 3. Equipotential terminal pin | 8. 2 x Gigabit Ethernet | 13. AC-in |
| 4. 2 x USB 3.2 (Type A) | 9. 2 x COM (RS-232) | |
| 5. 2 x USB 3.2 (Type A) | 10. Headphone-out | |

Figure 2.3 Rear View of Multiple I/O Ports (AC-In Model)

Note! *Equipotential terminal needs to be connected to the hospital ground/earth system before system boot to protect the operator and the system.*



2.2 Installation Procedures

2.2.1 Connecting the Power Cord

The POC-621-12 series can be powered by one of the DC adapters below.

Manufacturer Model	Voltage (Rating)	Current (Rating)	Note
SINPRO HPU150A-107	19V	7.89A	
DELTA MDS-150AAS19F	19V	7.89A	

Be sure to always handle the power cords by holding the plug ends only.

Follow these procedures in order:

1. Connect the female end of the power cord to the AC adapter.
2. Connect the 3-pin male plug of the power cord to an electrical outlet.

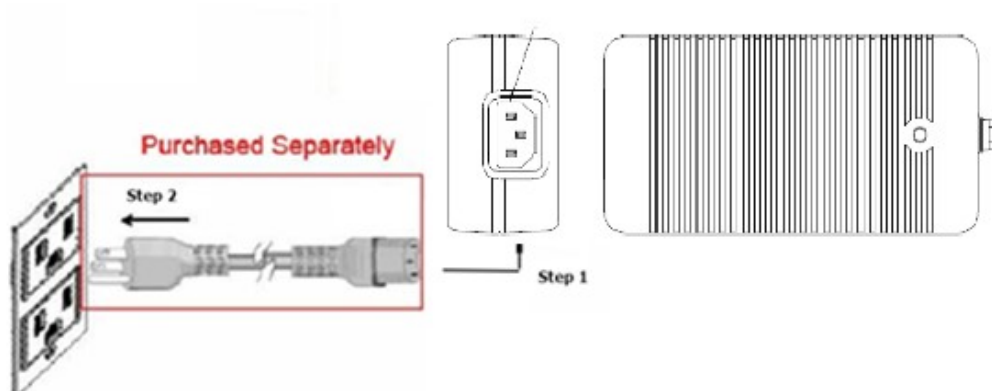

2.2.2 Connecting the DC-In

Connect the AC Adapter output to the DC-in of the POC system.

Caution! *The adapter DC-in plug has a specific direction. Please align the plug and DC-in connector correctly.*



Pin	Function	Note
1, 2	19V	
3, 4	Return	

Warning! *Connecting the AC adapter in the wrong direction may damage the POC system or adapter.*



Avertissement! *Le plugin miss direction peut endommager le système POC ou l'adaptateur.*



2.2.3 Connecting the Ground Pin

1. Find the equipotential terminal on the rear side of the POC terminal.
An equipotential terminal is provided to optionally connect to a hospital ground/earth system.

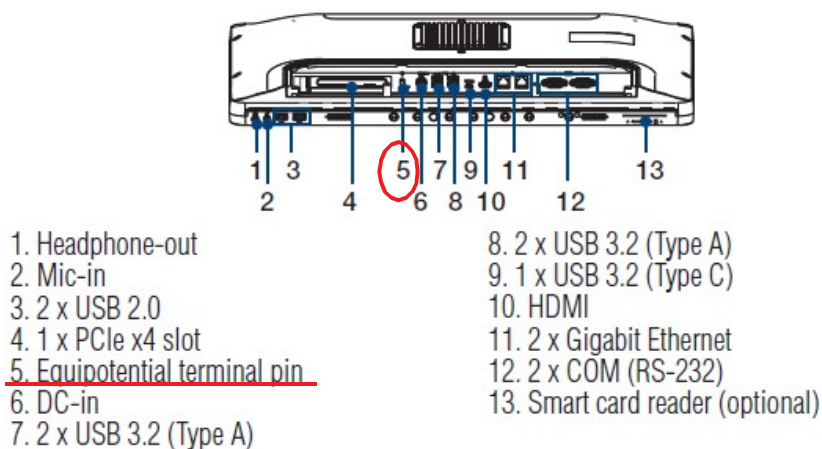

Figure 2.4 POC-621-12 Series Equipotential Terminal Pin

2. Prepare the grounding cable and the other terminal link to the hospital ground/earth system.



Figure 2.5 Grounding Cable with Connector

3. Grounding cable plug with POC-621-12 SERIES Equipotential Terminal (See Figure 2.5).

2.3 Running the BIOS Setup Program

Your POC-621-12 series unit was probably set up and configured by your dealer prior to delivery. You may still find it necessary to use the BIOS (Basic Input-Output System) setup program to change system configuration information, such as the current date and time or your type of hard drive. The setup program is stored in read-only memory. It can be accessed either when you turn on or reset the panel PC, by pressing the “F2” or “Del” key on your keyboard immediately after powering on the computer.

The settings you specify with the setup program are recorded in a special area of memory called CMOS RAM. This memory is backed up by a battery so that it will not be erased when you turn off or reset the system. Whenever you turn on the power, the system reads the settings stored in CMOS RAM and compares them to the equipment check conducted during the power on self-test (POST). If an error occurs, an error message will be displayed on the screen, and you will be prompted to run the setup program.

2.4 Installing System Software

Recent releases of operating systems from major vendors include setup programs which load automatically and guide you through hard disk preparation and operating system installation. The guidelines below will help you determine the steps necessary to install your operating system on the panel PC hard drive.

Note! *Some distributors and system integrators may have already pre-installed system software prior to shipment of your panel PC.*



If required, insert your operating system's installation or setup diskette into the external diskette drive until the release button pops out.

The BIOS supports system boot directly from the flash disk. You may also insert your system installation flash disk into a USB port.

Power on or reset the system by pressing the "Del" key to boot to the BIOS menu and adjust the boot device sequence.

You can also press the "F12" key when booting; a bootable device popup menu will appear. You can select the bootable device that you want to use. The Point-of-Care terminal will automatically load the operating system from the flash disk.

If you are presented with the opening screen of a setup or installation program, follow the instructions on the screen. The setup program will guide you through preparation of your hard drive and installation of the operating system.

2.5 Installing the Drivers

After installing your system software, you will be able to set up the chipset, graphics, Ethernet, and audio drivers.

The standard automatic installation procedures for installing the drivers are described in later chapters.

The various drivers and utilities on the CD-ROM disc have their own text files which help users install the drivers and understand their functions. These files are a very useful supplement to the information in this manual.

All drivers can be downloaded from the Advantech website.

2.6 Troubleshooting

When the system behaves abnormally, such as the in the conditions described in the sections below, please refer to the below instructions for troubleshooting.

2.6.1 POC not powering on

If the power button does not power on the unit (the green power indicator is still off), please check:

1. Check the AC adapter power cord and plug.
2. Check that the adapter and DC-in plug are connected in the correct direction.
3. Check that the AC adapter is properly connected to the AC power outlet.
4. If not using an AC adapter (battery powered mode), please check that the battery is installed properly with sufficient charge. Remove the battery pack and press the charge indicator button on the battery pack.



The illuminated LEDs represent the battery's state of charge.

	State-of-Charge
LED Green	<i>Current()</i> > 0
LED1	0%~20%
LED2	0~40%
LED3	0~60%
LED4	0~80%
LED5	0~100%

2.6.2 Adapter power LED is off

The adapter green LED remains off.

- 1) Check the AC power cord and plug are connected properly.
- 2) Check the AC power cord is properly plugged into the power outlet.

2.6.3 The POC system powers on but does not boot to Windows

The POC display shows a black background with some words.

1. Check that Windows OS is installed properly.
2. Check that the BIOS boot order is set up properly. Please set up the BIOS boot devices through the following procedure:
 - a) Press the "Del" key during power-up to access the BIOS menu.
 - b) Select Boot Option #1 – Select "Windows Boot Manager (Storage name)"
 - c) Save & Exit – Save Changes and Reset – Select Yes
 - d) The POC system will reset and boot up.

2.6.4 AC power is connected and all indicators are on, but the system doesn't power on

POC system power and the green LED indicator are on.

Please contact Advantech customer service for further support.

2.6.5 No charge

Please check:

1. Make sure the battery pack is installed properly. Push the battery pack inside the battery slot to make sure it is installed correctly.
2. Check that the cable is properly connected to DC-in.
3. The battery is designed to have a charge under 98% before it will receive a charge. This design can avoid charging too frequently. In other words, if the battery charge level is at 99% or 100%, the charger will not charge this battery.

Contact your distributor, sales representative, or Advantech's customer service center for technical support if you need additional assistance. Please have the following information ready before you call:

- Product name and serial number
- Description of your peripheral attachments
- Description of your software (operating system, version, application software, etc.)
- A complete description of the problem
- The exact wording of any error messages
- Symptoms, photos or, video if available

2.7 EMC Declaration

Guidance and Manufacturer's Declaration – Electromagnetic Emissions		
The POC-621-12 series device is intended for use in an electromagnetic environment as specified below. The customer or the user of the POC-621-12 series device should assure that it is used in such an environment.		
Emissions test	Compliance	Electromagnetic environment – guidance
RF emissions CISPR 11	Group 1	The POC-621-12 series device uses RF energy only for its internal functions. Therefore, its RF emissions are very low and are not likely to cause any interference in nearby electronic equipment.
RF emissions CISPR 11	Class B	The POC-621-12 series device is suitable for use in all establishments, including domestic establishments and those directly connected to the public low-voltage power supply network that supplies buildings used for domestic purposes.
Harmonic emissions IEC 61000-3-2	Class D	
Voltage fluctuations / flicker emissions IEC 61000-3-3	Meet the requirements	

Recommended Separation Distances Between Portable and Mobile Rf Communications Equipment and the POC-621-12 Series Device			
The POC-621-12 series device is intended for use in an electromagnetic environment in which radiated RF disturbances are controlled. The customer or the user of the POC-621-12 can help prevent electromagnetic interference by maintaining a minimum distance between portable and mobile RF communications equipment (transmitters) and the POC-621-12 series device as recommended below, according to the maximum output power of the communications equipment.			
Rated maximum output power of transmitter W	Separation distance according to frequency of the transmitter m		
	150 kHz to 80 MHz $d = 1,2 \sqrt{P}$	80 MHz to 800 MHz $d = 1,2 \sqrt{P}$	800 MHz to 2,5 GHz $d = 2,3 \sqrt{P}$
0,01	0,12	0,12	0,23
0,1	0,38	0,38	0,73
1	1,2	1,2	2,3
10	3,8	3,8	7,3
100	12	12	23
For transmitters rated at a maximum output power not listed above, the recommended separation distance d in metres (m) can be estimated using the equation applicable to the frequency of the transmitter, where P is the maximum output power rating of the transmitter in watts (W) according to the transmitter manufacturer. NOTE 1: At 80 MHz and 800 MHz, the separation distance for the higher frequency range applies. NOTE 2: These guidelines may not apply in all situations. Electromagnetic propagation is affected by absorption and reflection from structures, objects, and people.			

Guidance and Manufacturer's Declaration – Electromagnetic Immunity

The POC-621-12 series device is intended for use in the electromagnetic environment specified below. The customer or the user of the model POC-621-12 series device should ensure that it is used in such an environment.

Immunity test	IEC 60601 test level	Compliance level	Electromagnetic environment – guidance
<p>Electrostatic discharge (ESD) IEC 61000-4-2 Electrical fast transient/burst IEC 61000-4-4</p> <p>Surge IEC 61000-4-5 Interruptions and voltage variations on power supply input lines IEC 61000-4-11</p> <p>Power frequency (50/60 Hz) magnetic field IEC 61000-4-8</p>	<p>±8 kV contact ±15 kV air</p> <p>±2 kV for power supply lines ±1 kV for input/output lines ±1 kV line(s) to line(s) ±2 kV line(s) to earth</p> <p>Voltage Dips: i) 0% reduction for 0.5 cycle at 50Hz, 0% reduction for 1 cycle at 50Hz Performance Criterion B ii) 70% reduction for 25/30 cycles at 50/60Hz Performance Criterion C</p> <p>Voltage Interruptions: 0% reduction for 250/300 cycles at 50/60Hz Performance Criterion C 30A/m</p>	<p>±8 kV contact ±15 kV air</p> <p>±2 kV for power supply lines ±1 kV for input/output lines ±1 kV line(s) to line(s) ±2 kV line(s) to earth</p> <p>Voltage Dips: i) 0% reduction for 0.5 cycle at 50Hz, 0% reduction for 1 cycle at 50Hz Performance Criterion B ii) 70% reduction for 25/30 cycles at 50/60Hz</p> <p>Performance Criterion C</p> <p>Voltage Interruptions: 0% reduction for 250/300 cycles at 50/60Hz Performance Criterion C 30A/m</p>	<p>Floors should be wood, concrete or ceramic tile. If floors are covered with synthetic material, the relative humidity should be at least 30%.</p> <p>Main power quality should be that of a typical commercial or hospital environment.</p> <p>If the user of the model POC-621-12 requires continued operation during main power interruption, it is recommended that the model POC-621-12 be powered from an uninterruptible power supply.</p> <p>Power frequency magnetic fields should be at levels characteristic of a typical location in a typical commercial or hospital environment.</p>
<p>NOTE: <i>UT</i> is the AC mains voltage prior to application of the test level.</p>			

Guidance and Manufacturer's Declaration – Electromagnetic Immunity			
The POC-621-12 series device is intended for use in the electromagnetic environment specified below. The customer or the user of the POC-621-12 series device should ensure that it is used in such an environment.			
Immunity test	IEC 60601 test level	Compliance level	Electromagnetic environment – guidance
Conducted RF IEC 61000-4-6	3 and 6 Vrms 150 kHz to 80 MHz and specific ISM, AM frequency 3 and 6 Vrms	3 and 6 Vrms 150 kHz to 80 MHz and specific ISM, AM frequency	Portable and mobile RF communications equipment should be used no closer to any part of the POC-621-12 series device, including cables, than the recommended separation distance calculated from the equation applicable to the frequency of the transmitter. Recommended separation distance $d = 1,2\sqrt{P}$ $d = 1,2\sqrt{P}$ 80 MHz to 800 MHz $d = 2,3\sqrt{P}$ 800 MHz to 2,5 GHz where P is the maximum output power rating of the transmitter in watts (W) according to the transmitter manufacturer and d is the recommended separation distance in meters (m).
Radiated RF IEC 61000-4-3	3V/m 80 MHz to 2.7 GHz, and specific frequency	3V/m 80 MHz to 2.7 GHz, and specific frequency	Field strengths from fixed RF transmitters, as determined by an electromagnetic site survey, ^a should be less than the compliance level in each frequency range. ^b Interference may occur in the vicinity of equipment marked with the following symbol: 
NOTE 1: At 80 MHz and 800 MHz, the higher frequency range applies. NOTE 2: These guidelines may not apply in all situations. Electromagnetic propagation is affected by absorption and reflection from structures, objects, and people.			

^a Field strengths from fixed transmitters, such as base stations for radio (cellular/cordless), telephones, land mobile radios, amateur radio, AM and FM radio broadcast, and TV broadcast cannot be predicted theoretically with accuracy. To assess the electromagnetic environment due to fixed RF transmitters, an electromagnetic site survey should be considered. If the measured field strength in the location in which the POC-621-12 series device is used exceeds the applicable RF compliance level above, the POC-621-12 series device should be observed to verify normal operation. If abnormal performance is observed, additional measures may be necessary, such as reorienting or relocating the POC-621-12 series device.

^b Over the frequency range 150 kHz to 80 MHz, field strengths should be less than 3 V/m.

Chapter 3

Operation and Safety

3.1 General Safety Guide

For your own safety and that of your equipment, always take the following precautions.

Disconnect the power plug (by pulling the plug, not the cord), from your computer if any of the following conditions exists:

- The power cord or plug is frayed or otherwise damaged.
- Any substance is spilled on the POC system.
- The POC system has been dropped or the case has been damaged.
- The POC system needs servicing or repair.
- To clean the POC system.
- To remove/install any internal parts (excluding installation or removal of the-hotswap battery pack).

3.2 Thermal

The vent hole of the POC series unit on the rear cover functions as a cooling airflow inlet and outlet. These sorts of inlets and outlets transfer heat from inside the computer to the cooler air outside. Do not block these holes/vents with any soft material.

When using your POC series device, it is normal for the rear metal heatsink to get warm. The rear metal heatsink of the POC device functions as a cooling surface that transfers heat from inside the computer to the cooler air outside.

Do not block this heatsink with any soft material.

To protect the battery pack from overheating, use/charge the battery in accordance with the instructions provided in the user manual.

- Warning!**
- 
1. *Temperatures that are too high or too low may damage the battery.*
 2. *Do not place your POC system on a pillow or other soft material when it is on, as the material may block the airflow and cause the system to overheat.*

- Avertissement!**
- 
1. *Des températures trop élevées ou trop basses peuvent endommager la batterie.*
 2. *Ne placez pas votre système POC-621-12 sur un oreiller ou un autre matériau souple lorsqu'il est allumé, car le matériau peut bloquer le flux d'air et provoquer une surchauffe du système.*

Charge the battery and use it according to the datasheet.

- Warning!**
- 
1. *If the temperature is too high or too low, your batteries may be damaged.*
 2. *If the temperature is too high or too low, your batteries may stop charging. The battery should continue charging when its temperature returns to within the normal range.*

- Avertissement!**
- 
1. *Si la température est trop élevée ou trop basse, vos batteries peuvent être endommagées.*
 2. *Si la température est trop élevée ou trop basse, vos batteries peuvent arrêter la charge. La batterie peut redémarrer la charge lorsque sa température revient à une température spécifique.*

3.3 Disconnect the Power

The only way to disconnect power completely is to unplug the power cord. Make sure at least one end of the power cord is within easy reach so that you can unplug the computer when you need to.

Warning! *Your AC cord came equipped with a three-wire grounding plug (a plug that has a third grounding pin). This plug will only fit a grounded AC outlet. If you are unable to insert the plug into an outlet because the outlet is not grounded, contact a licensed electrician to replace the outlet with a properly grounded outlet.*



Do not defeat the purpose of the grounding plug.

Avertissement! *Votre cordon d'alimentation est équipé d'une fiche de mise à la terre à trois fils (une fiche qui a une troisième broche de mise à la terre). Cette fiche s'adapte uniquement à une prise secteur mise à la terre. Si vous ne parvenez pas à insérer la fiche dans une prise parce que la prise n'est pas mise à la terre, contactez un électricien agréé pour remplacer la prise par une prise correctement mise à la terre. Ne supprimez pas la fonction de la fiche de mise à la terre.*



Warning! *Never push objects of any kind into this product through the openings in the case.*



Doing so may be dangerous and result in fire or a dangerous electric shock.

Never place anything on the system case before turning off the computer.

Never turn on your computer unless all of its internal and external parts are in place.

Operating the computer when it is open or missing parts can be dangerous and can damage your computer.

Avertissement! *Ne poussez jamais d'objets d'aucune sorte dans ce produit à travers les ouvertures du boîtier. Cela pourrait être dangereux et entraîner un incendie ou un choc électrique dangereux.*



Ne placez jamais rien sur le boîtier du système avant d'éteindre l'ordinateur.

N'allumez jamais votre ordinateur tant que toutes ses pièces internes et externes ne sont pas en place.

Faire fonctionner l'ordinateur lorsqu'il est ouvert ou qu'il manque des pièces peut être dangereux et peut endommager votre ordinateur.

3.4 Proper Handling

Handle your POC system with care. The system is made of metal, glass, and plastic and contains sensitive electronic components. Because the POC system is a heavy object, please use two hands to handle it.

Hold the battery with both hands when installing, removing, or replacing a battery pack.

Warning! Do not attempt to use the POC system if it is damaged (for example, the case is cracked or broken) as this may cause injury.



Caution! 1) Set up and install the POC system on a stable work surface.



2) Do not push objects into the ventilation openings.

3) This SINPRO HPU150A-107 and DELTA MDS-150AAS19F adapter are medical-grade adapters.

Avertissement! N'essayez pas d'utiliser le système POC-621-12 s'il est endommagé (par exemple, le boîtier est fissuré ou cassé) car cela pourrait provoquer des blessures.



Attention! 1. Configurez et installez le système POC-621-12 sur une surface de travail stable.



2. Ne poussez pas d'objets dans les ouvertures de ventilation.

3.5 Battery Warnings

Please read these safety instructions and warnings before using or charging the battery.

Warning! Li-ion battery packs may explode and cause fire if defective or used incorrectly. To prevent this from happening, follow all usage instructions and safety guidelines provided in this user manual.



Avertissement! Les batteries Li-ion peuvent exploser et provoquer un incendie si elles sont défectueuses ou mal utilisées. Pour éviter que cela ne se produise, suivez toutes les instructions d'utilisation et les consignes de sécurité fournies dans ce manuel d'utilisation.





- Caution!**  1. Removal of the POC system battery pack and unplugging of the power cord will cause the connected POC system to shut down, which may result in data losses. To prevent the loss of information, always save your work and shut down the POC system via Windows OS before removing the battery or power cord.
2. Lithium batteries have a predetermined life span. Replace old batteries with new batteries when they have reached the end of their service life (the warranty is for 1 year or 300 cycles with 70% normal capacity, according to which occurs first).

- Attention!**  1. Le retrait de la batterie du système POC-621-12 et le débranchement de l'adaptateur secteur entraîneront l'arrêt du système POC-621-12 connecté, ce qui peut entraîner des pertes de données. Pour éviter la perte d'informations, enregistrez toujours votre travail et arrêtez le système POC-621-12 via le système d'exploitation Windows avant de retirer la batterie ou l'adaptateur secteur.
2. Les batteries au lithium ont une durée de vie prédéterminée. Remplacez les vieilles piles par des piles neuves lorsqu'elles ont atteint la fin de leur durée de vie (la garantie est de 1 an ou 300 cycles avec 70% de capacité normale, selon ce qui survient en premier).

3.6 Battery Safety Instructions

1. The POC system should only be powered by an Advantech battery pack or compatible battery pack supplied by Advantech.

- Warning!**  1. Do not insert non-Advantech battery packs into the POC system.
2. Do not attempt to use battery packs of a different brand.

- Avertissement!**  1. N'insérez pas de blocs-batteries non Advantech dans le système POC.
2. N'essayez pas d'utiliser des batteries d'une marque différente.

2. Do not make the wrong polarity connection when charging and using battery packs. Always double check the battery installation direction before insertion or connection with the charger.

- Warning!**  Batteries installed in the wrong direction with the opposite polarity are at risk of exploding, which may cause fire.

- Avertissement!**  Les batteries installées dans le mauvais sens avec la polarité opposée risquent d'exploser, ce qui peut provoquer un incendie.

3. Only use the specific Li-ion battery charger provided by Advantech to charge the battery pack.

Warning! *Using a battery charger of a different brand may cause the battery to explode and result in fire.*



Avertissement! *L'utilisation d'un chargeur de batterie d'une marque différente peut entraîner la exploser et provoquer un incendie.*



4. Do not short the battery pack connector using metal or a wire lead.

Warning! *Wire lead shorts can cause the battery to explode and result in fire.*



Avertissement! *Les courts-circuits du fil peuvent provoquer l'explosion de la batterie et provoquer un incendie.*



5. Do not drop the battery pack.

Warning! *If the battery cover is cracked, split, or broken, do not use the battery.*



Avertissement! *Si le couvercle de la batterie est fissuré, fendu ou cassé, n'utilisez pas la batterie.*



6. Do not expose the battery pack to fire or high temperatures.

Warning! *Exposure to high temperatures may cause the battery to explode.*



Avertissement! *L'exposition à des températures élevées peut provoquer l'explosion de la batterie.*



7. Do not penetrate the battery with nails, strike the battery with a hammer, step on the battery, or otherwise subject it to significant impact or shock.

Warning! Batteries are at risk of exploding and may cause fire if subjected to significant impact.



Avertissement! Les batteries risquent d'exploser et de provoquer un incendie si elles sont soumises à impact significatif.



8. Do not expose the battery pack to moisture or water.
9. Do not disassemble or modify the battery pack. The battery pack contains safety and protection circuits that if damaged, may cause the battery to overheat, explode, or ignite. There are no user-serviceable parts inside the battery pack.
10. Always refer to the user manual for charging instructions.
11. Charge the battery pack in indoor environments with a controlled temperature.

Caution! Exposure to extreme temperatures can damage the battery and reduce the battery life capacity.



Attention! L'exposition à des températures extrêmes peut endommager la batterie et réduire la capacité de la batterie.



12. Do not leave fully charged battery packs connected to the computer for prolonged periods of time.

Caution! When the battery is fully recharged, disconnect it from the charger or unplug the charger power cable.



Attention! Lorsque la batterie est complètement rechargée, déconnectez-la de l'ordinateur ou débranchez le câble d'alimentation.



13. Do not discharge the battery pack using any device other than the POC system or a device specified by Advantech.

Warning! *Using the battery pack to power devices other than the POC system may damage the battery, limit performance, or reduce the battery life capacity. Additionally, exposure to abnormal current may cause the battery pack to overheat, explode, or ignite, causing serious injury.*



Avertissement! *L'utilisation de la batterie pour alimenter des appareils autres que le système POC peut endommager la batterie, limiter les performances ou réduire la durée de vie de la batterie. De plus, une exposition à un courant anormal peut entraîner une surchauffe, une explosion ou une inflammation de la batterie, entraînant des blessures graves.*



14. Use/discharge the battery pack in indoor environments with a controlled temperature.

Caution! *Using the battery in environments with temperatures outside the acceptable range may damage the battery, limit performance, or reduce the battery life capacity.*



Attention! *L'utilisation de la batterie dans des environnements avec des températures en dehors de la plage acceptable peut endommager la batterie, limiter les performances ou réduire la durée de vie de la batterie.*



15. Inspect all battery packs before use.

Warning! 1) *Never use battery packs that are visibly damaged or that may have internal damage.*



2) *Never remove the battery's outer cover or use a battery pack with a damaged cover.*

Avertissement! 1) *N'utilisez jamais de blocs-piles visiblement endommagés ou dommages internes.*



2) *Ne retirez jamais le couvercle extérieur de la batterie et n'utilisez jamais de batterie avec un couverture endommagée.*

16. Replace the entire battery pack with a new battery pack when the time between charges decreases significantly.

Caution! *When the time between charges decreases significantly, check the voltage of the battery pack before charging. If the battery performance drops significantly, please do not use this battery pack.*



Attention! *Lorsque le temps entre les charges diminue considérablement, vérifiez la tension de la batterie avant de la charger. Si les performances de la batterie diminuent considérablement, veuillez ne pas utiliser cette batterie.*



3.7 Emergency Scenarios

If you notice any of the following, stop charging or using the battery immediately:

1. The battery has become swollen, bulging, or deformed.
2. The battery is leaking fluid, smoke, or a foul odor.
3. The battery temperature is extremely hot.
4. The battery appears abnormal in any way.
5. The battery cover is cracked, split, or broken.
6. The battery has been exposed to moisture.

Warning! 1. *If any of the above conditions are observed, place the battery pack and charger outside on a concrete floor, away from any flammable materials for approximately 15 minutes and contact Advantech. Do not attempt to reuse the battery pack.*



2. *In the event that the battery is leaking and the fluid gets into your eye, rinse well with water and immediately seek medical care. If left untreated, exposure to battery fluid could damage your eye.*

Avertissement! 1. *Si l'une des conditions ci-dessus est observée, placez la batterie et le chargeur à l'extérieur sur un sol en béton, à l'écart de tout matériau inflammable pendant environ 15 minutes et contactez Advantech. N'essayez pas de réutiliser la batterie.*



2. *Si la pile fuit et que le liquide pénètre dans vos yeux, rincez abondamment à l'eau et consultez immédiatement un médecin. Si elle n'est pas traitée, l'exposition au liquide de la batterie peut endommager vos yeux.*

3.8 Battery Storage and Transportation

1. Store the battery in a dry environment with a room temperature of 0 ~ 25°C (32 ~ 77°F) for optimum health.
2. Do not expose the battery pack to direct sunlight (heat) or store the battery pack inside vehicles in hot weather for extended periods.
3. When transporting or temporarily storing the battery in a vehicle, the internal vehicle temperature should be greater than -20°C (-4°F) but no more than 50°C (122°F).
4. If possible, remove the battery pack from the device if the device will be unused for several months.
5. Do not remove individual battery packs from the original packaging until required for use.

Warning! *To reduce the risk of damage, do not expose battery packs to high temperatures for extended periods of time. This may damage the battery and cause fire.*



Avertissement! *Pour réduire le risque de dommages, n'exposez pas les batteries à des températures élevées pendant des périodes prolongées. Cela pourrait endommager la batterie et provoquer un incendie.*



Caution!

1. *Stored batteries should be checked every 3 months. If the capacity is less than 50%, recharge the battery before returning it to storage.*
2. *Batteries may leak if left in the device for extended periods of time. After long periods of storage, check the battery pack before charging.*



Attention!

1. *Les batteries stockées doivent être vérifiées tous les 3 mois. Si la capacité est inférieure à 50%, rechargez la batterie avant de la remettre en stockage.*
2. *Les piles peuvent fuir si elles sont laissées dans l'appareil pendant de longues périodes. Après de longues périodes de stockage, vérifiez la batterie avant de la charger.*



3.9 Battery Disposal

When the battery pack has reached the end of its service life, do not use general household waste for disposal. Follow local laws and government regulations for correct battery disposal.

Caution! *Cover terminals with tape to prevent inadvertent contact with other batteries or metal objects. Cover terminals with tape to prevent inadvertent contact with other batteries or metal objects.*



Warning!

1. *To reduce the risk of fire or burns, do not disassemble, crush, puncture, expose to fire or water, or short the battery's external contacts.*
2. *Used batteries may still have a partial charge. If partially charged batteries come into contact with other batteries or metal objects, the remaining stored energy may be discharged and cause a fire or explosion.*



Attention! *Couvrez les bornes avec du ruban adhésif pour éviter tout contact accidentel avec d'autres batteries ou des objets métalliques. Couvrez les bornes avec du ruban adhésif pour éviter tout contact accidentel avec d'autres batteries ou des objets métalliques.*



Avertissement!

1. *Pour réduire le risque d'incendie ou de brûlure, ne démontez pas, n'écrasez pas, ne percez pas, n'exposez pas au feu ou à l'eau, et ne court-circuitiez pas les contacts externes de la batterie.*
2. *Les batteries usagées peuvent encore avoir une charge partielle. Si des batteries partiellement chargées entrent en contact avec d'autres batteries ou des objets métalliques, l'énergie stockée restante peut être déchargée et provoquer un incendie ou une explosion.*



Chapter 4

VESA Mount Installation

4.1 VESA Mount Installation

The POC series also provides standard VESA mounting to help system integrators conveniently integrate the panel PC into their systems.

Never use mounting brackets except as provided by Advantech to prevent unreliable mounting of the POC Series. VESA mount installation should be carried out by a professional technician; please contact a service technician or your retailer if you need this service.

Installation instructions:

1. First, attach the wall-mount to the heat-sink of the POC-621-12 series device, securing it in place with four of the philips-head screws provided.
2. Mount the device on the wall, stand, or other flat surface.

Warning! *Be sure to secure the screws of the mounting bracket tightly. A loose joint between the POC series device and the mounting bracket may create risk of injury.*



Avertissement! *Assurez-vous de bien serrer les vis du support de montage. Un joint lâche entre la SÉRIE POC-621-12 et le support de montage peut créer un risque de blessure.*

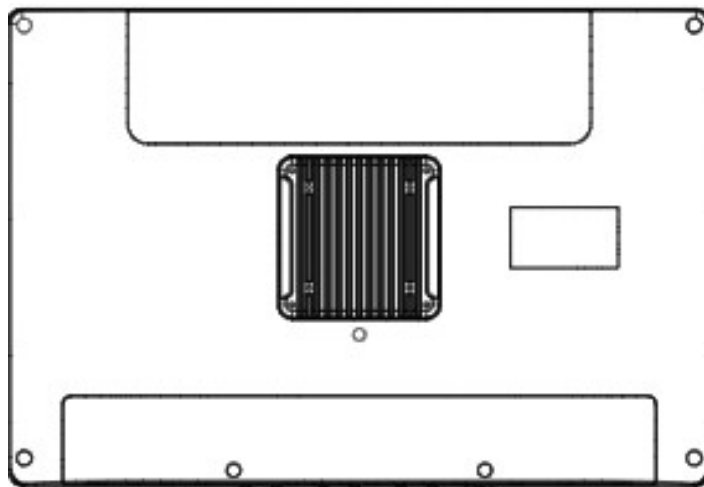

Figure 4.1 VESA Mounting

Chapter 5

Driver Installation

5.1 Driver Installation

The POC system supports Windows, version WIN10 IOT/RS5 later, 64-bit only. It no longer supports 32-bit drivers.

Warning! Please use a clean OS installation to install the drivers; otherwise, it might cause unexpected errors.



Avertissement! Veuillez utiliser un système d'exploitation propre pour installer le pilote, sinon cela pourrait provoquer une erreur inattendue.



Windows Driver List:

Please follow your OS version to install the proper drivers.

Please follow below sequence to install drivers.

Install Sequence	Folder Name	Note
1	Chipset	Please install chipset driver first.
2	Graphics	Because Windows update will downgrade this graphics driver, please install the graphics driver again after a Windows update. After the 2nd graphics driver installation, Windows update will not downgrade the graphics driver.
3	Audio	
4	LAN	<ol style="list-style-type: none">1. Install LAN driver first.2. Install Proset utility tool after above LAN driver installed.
5	AMT/ME	Intel Management Engine Driver
6	RST/VMD	Intel RST/VMD Driver. Different Win10 version need to install specific RST/VMD driver. <ol style="list-style-type: none">1. For WIN10 20H2 and later/WIN11, install RST version 18.72. For WIN10 1909 and before, install RST version 18.4
7	Serial I/O	
7	Wireless Card (Wi-Fi+Bluetooth)	Option Please install both Wi-Fi and Bluetooth drivers.
8	RFID	Optional
9	Smart Card	Optional

Chapter 6

PCM-8725 Connector Map

6.1 POC System with PCM-8725 PCBA

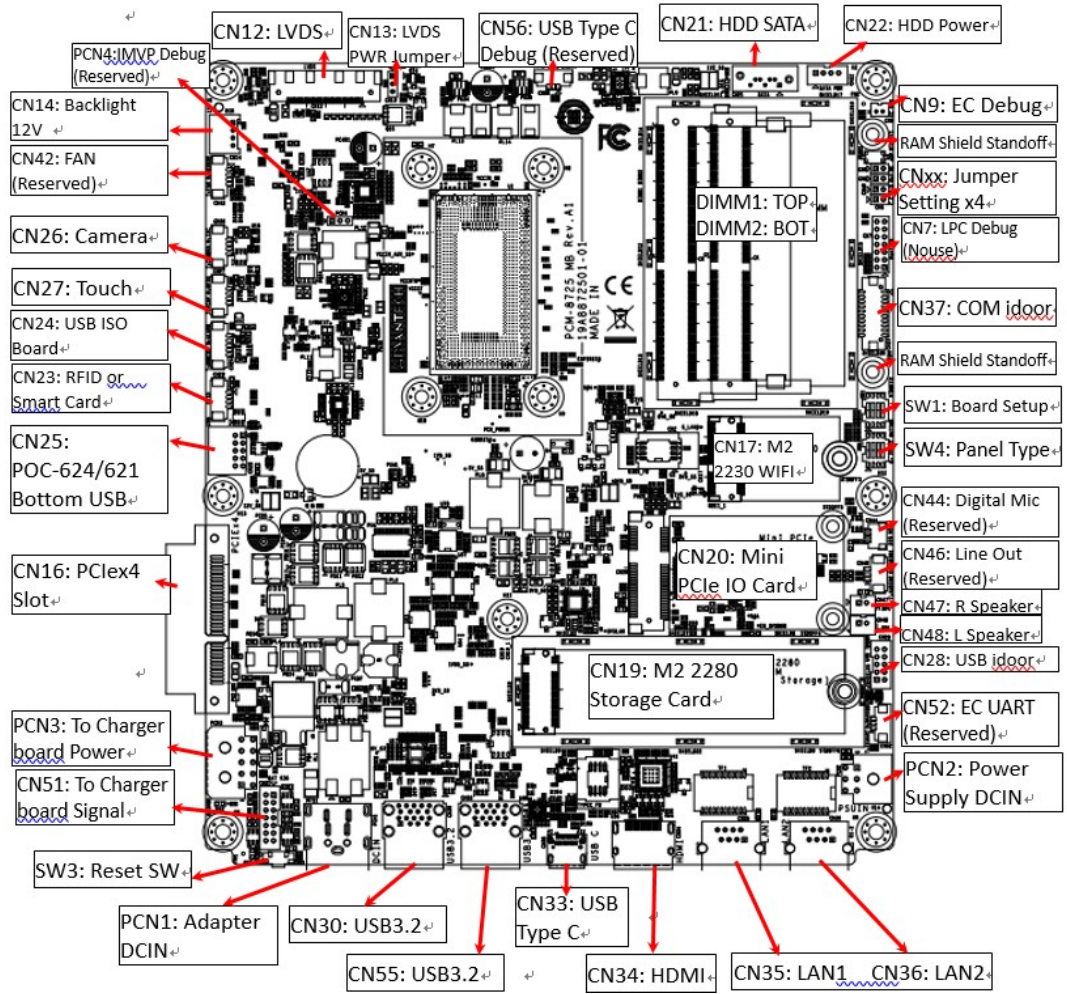

Figure 6.1 Motherboard Top Side

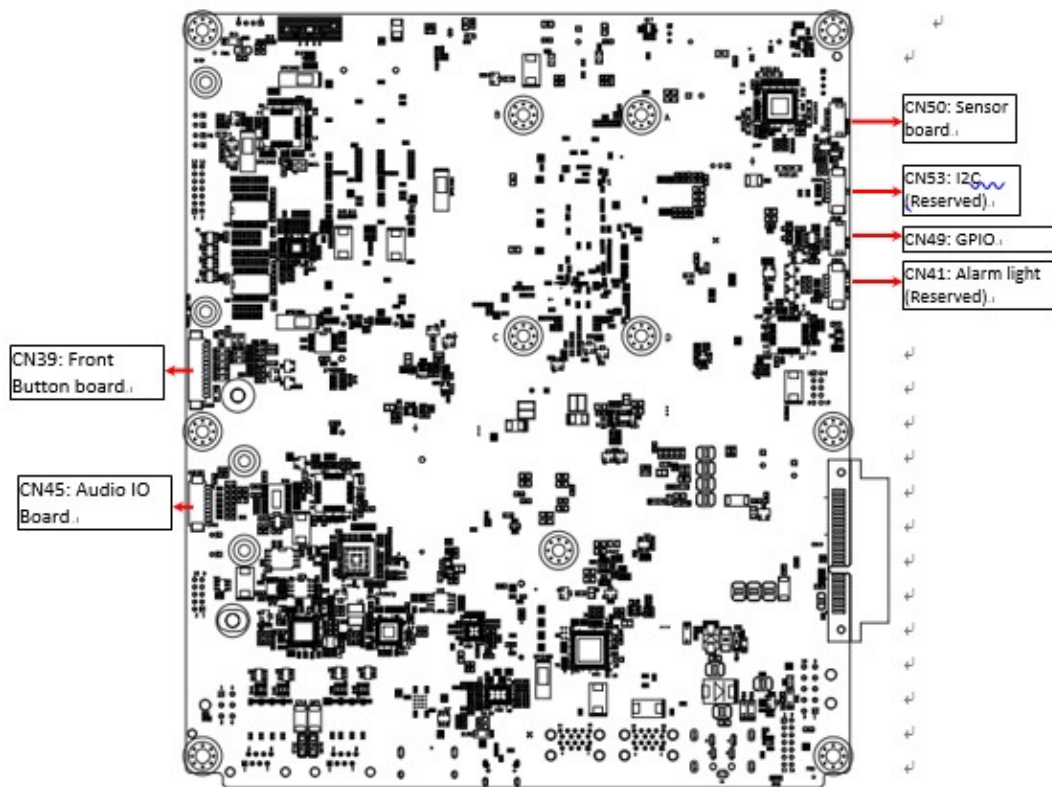

Figure 6.2 Motherboard Bottom Side

Chapter 7

PCM-8725 Jumper Settings

7.1 PCM-8725 Jumper Settings

The POC system utilizes the PCM-8725 PCBA. All jumpers and DIP switches are located on the MB Top side.

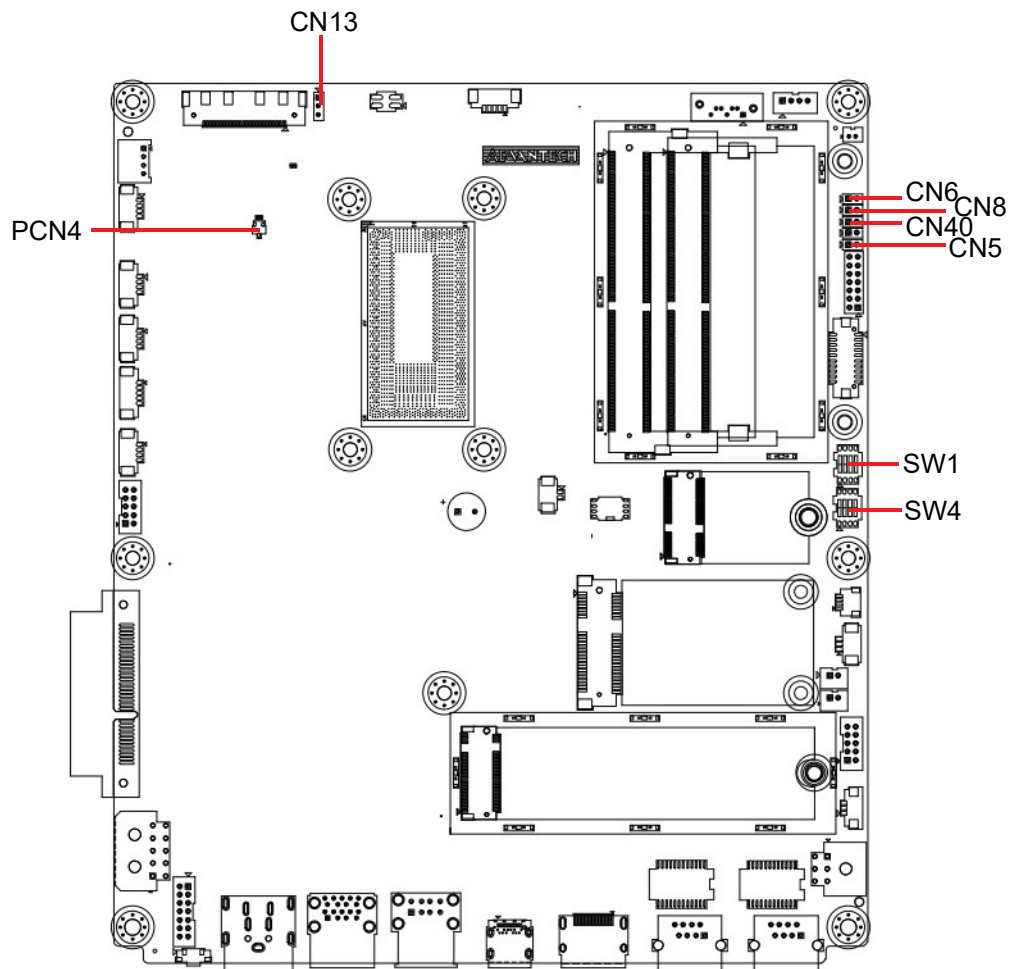

Figure 7.1 Motherboard Top Side

7.1.1 Jumper Settings:

CN6	ME Manufacturing Mode
CN5	Clear CMOS
CN8	System Reset (Reserved, Internal Test Only)
CN13	LVDS Voltage
CN40	Power Button (Reserved, Internal Test Only)
PCN4	Power Debug (Reserved, Internal Test Only)
SW1	Board Setup
SW4	Panel Setup

Table 7.1: CN6 ME Manufacturing Mode

Description	ME Manufacturing Mode
Setting	Function
(1-2)	ME Manufacturing Mode
(No Connect)	Normal Operation (Default)

**Table 7.2: CN5 Clear CMOS**

Description	Clear CMOS Setup
Setting	Function
(1-2)	Clear CMOS Setup
(No Connect)	Normal Operation (Default)

**Table 7.3: CN8 System Reset (Reserved, Internal Test Only)**

Description	Reset System Button
Setting	Function
(1-2)	System Reset
(No Connect)	Normal Operation (Default)

**Table 7.4: CN13 LVDS Voltage Setup**

Description	Select Panel LVDS Voltage Setting
Setting	Function
(1-2)	Panel LVDS voltage 5V (Default)
(2-3)	Panel LVDS voltage 3.3V

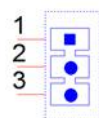

Table 7.5: CN40 Power Button (Reserved, Internal Test Only)

Description	Power Button Signal
Setting	Function
(Pin 2)	Short pin 1 to Power ON system
(No Connect)	Normal Operation (Default)

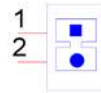

Table 7.6: PCN4 Power Debug (Reserved, Internal Test Only)

Description	Power Debug, Internal Test Only
Setting	Function
(No Connect)	Normal Operation (Default)

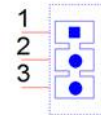
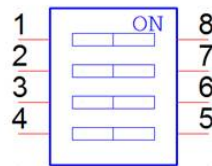

Table 7.7: SW1 Board Setup

Description	Select Board Setting
Setting	Function
(SW1-1/2/3)	Select Board Type
(SW1-4)	Force Speaker Always ON



SW1 Pin 1	SW1 Pin 2	SW1 Pin 3	Board Configuration
Hi(OFF)	Hi(OFF)	Hi(OFF)	Board Config 1 (Default)
Hi(OFF)	Hi(OFF)	Low(ON)	Board Config 2
Hi(OFF)	Low(ON)	Hi(OFF)	Board Config 3
Hi(OFF)	Hi(OFF)	Hi(OFF)	Board Config 4
Low(ON)	Hi(OFF)	Hi(OFF)	Board Config 5
Low(ON)	Hi(OFF)	Low(ON)	Board Config 6
Low(ON)	Low(ON)	Hi(OFF)	Board Config 7
Low(ON)	Hi(OFF)	Hi(OFF)	Board Config 8

Table 7.8: SW1 Pin 4 Speaker Function

Hi (OFF)	Speaker Mute when audio is plugged in – with Audio board system default
Low (ON)	Speaker Always ON – without Audio board system default

Table 7.9: SW4 Panel Resolution/Type Setup

Description	Select Panel Setting
Setting	Function
(SW2-1~4)	Select Panel Type

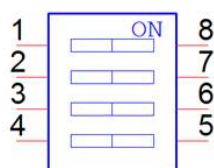

SW4 Pin 1	SW4 Pin 2	SW4 Pin 3	SW4 Pin 4	Panel Resolution	LVDS Channel
Hi(OFF)	Hi(OFF)	Hi(OFF)	Hi(OFF)	1920x1200	24 bits Dual
Low(ON)	Hi(OFF)	Hi(OFF)	Hi(OFF)	1920x1080 (Default)	24 bits Dual
Hi(OFF)	Hi(OFF)	Low(ON)	Hi(OFF)	1600x900	24 bits Dual
Low(ON)	Low(ON)	Low(ON)	Hi(OFF)	1366x768	24 bits Single
Low(ON)	Hi(OFF)	Hi(OFF)	Low(ON)	1280x1024	24 bits Dual
Low(ON)	Hi(OFF)	Low(ON)	Low(ON)	1024x768	24 bits Single
Low(ON)	Low(ON)	Low(ON)	Low(ON)	800x600	18 bits Single

POC-621-12 System Default

POC-621-12, with audio board, 5V LVDS Panel

SW1 Pin 1	SW1 Pin 2	SW1 Pin 3	SW1 Pin 4	SW2 Pin 1	SW2 Pin 2	SW2 Pin 3	SW2 Pin 4	CN13
Hi(OFF)	Hi(OFF)	Hi(OFF)	Hi(OFF)	Low(ON)	Hi(OFF)	Hi(OFF)	Hi(OFF)	(1-2)

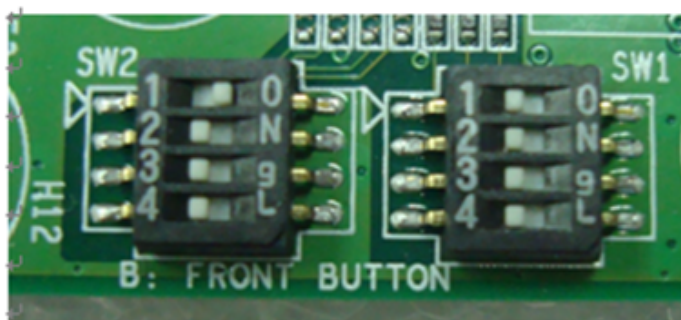

Chapter 8

Front Bezel Button







8.1 Introduction

POC system front button function descriptions.

Front button map



Button description:

Power button		Press this button to power the system on/off. When the system is ON, this icon will become Green. The LED will be off when the system is off.
Reduce volume		Press this button to reduce speaker and headphone volume
Increase Volume		Press this button to increase speaker and headphone volume
Touch disable		Press this button to disable/enable the touch function. When the touch function is enabled, this icon will become Green. When disabled, the LED will be off.
Read light		Press this button to enable/disable the Read light.
Reduce brightness		Press this button to reduce LCD backlight brightness
Increase brightness		Press this button to increase LCD backlight brightness

Combination button:

A special function is to turn the backlight off. When you press both “reduce brightness” and “increase brightness” at the same time for half a second, the LCD backlight will turn off. When you press both buttons again for half a second, the LCD backlight will turn on.

When the backlight is off, the POC system will still be running, and it will not impact the operation of any programs.

This “backlight off” function can be used in a hospital environment.

If an operator needs to check a photo in a dark environment, the operator can turn off the backlight quickly to prevent interfering with the dark environment.

The operator can turn off the backlight at night to prevent interference with the patient's sleep.

This “backlight off” event will return back to “backlight on” automatically after the next time the system is shut down and turned back on.

Chapter 9

Advanced BIOS Functions

9.1 Advanced BIOS Functions

This section will introduce the advanced functions of the POC system in the BIOS menu.

1. Power Button Function Enable/Disable

You can enable/disable the power button function in the BIOS menu.

If you disable the power button in S0 (System ON) status, the power button will not work. In that case, the user will not be able to turn off the system with the power button. The user will need to turn off system from the software. This function can prevent accidental shutting down of the system.

BIOS Menu location:

BIOS Menu – Advanced – IT5121 HW Monitor – Power Button Function

- Enable: The power button function works when the system is in S0 (System ON) status. (Default)
- Disable: The power button function will not work when the system is in S0 (System ON) status.
Disabling the power button function will cause the system to not be powered on by pressing the power button. When you set this function to “disable”, BIOS will set the “State After G3” to “Power On” automatically. Then you can plug in a power adapter to turn on the POC system.

2. Brightness Button Control

You can enable/disable the LCD Backlight button function in BIOS menu.

If you disable the LCD Backlight button, this button will not work. The user will not be able to adjust the LCD backlight luminance with this button. This function can prevent accidental adjustment of the LCD backlight luminance.

BIOS Menu location:

BIOS Menu – Advanced – IT5121 HW Monitor – Brightness Button Control

- Enable: Front bezel LCD Backlight adjust button control function is enabled. (Default)
- Disable: Front bezel LCD Backlight adjust button control function is disabled.

3. Volume Button Control

You can enable/disable the Front volume button function in the BIOS menu.

If you disable the Front volume button, this button will not work. The user will not be able to adjust the speaker volume with this button. This function can prevent accidental adjustment of the speaker volume with the front button.

BIOS Menu location:

BIOS Menu – Advanced – IT5121 HW Monitor – Volume Button Control

- Enable: Front bezel volume adjust button control function is enabled. (Default)
- Disable: Front bezel volume adjust button control function is disabled.

4. Touch Button Control

You can enable/disable Touch button functionality in the BIOS menu.

If you disable the Touch button, this button will not work. In that case, the user will not be able to turn off Touch functionality with this button. The Touch function will always be on.

BIOS Menu location:

BIOS Menu – Advanced – IT5121 HW Monitor – Touch Button Control

- Enable: Front bezel Touch button control function is enabled. (Default)
- Disable: Front bezel Touch button control function is disabled.

5. Read Light Button Control

You can enable/disable the Read light button function in the BIOS menu.

If you disable the Read light button, this button will not work. In that case, the user will not be able to turn on the Read light with this button. The Read light function will always be off.

BIOS Menu location:

BIOS Menu – Advanced – IT5121 HW Monitor – Read light Control

- Enable: Front bezel Read light button control function is enabled. (Default)
- Disable: Front bezel Read light button control function is disabled.

6. EC Beep Function

You can enable/disable the EC beep function in the BIOS menu.

If you disable the EC beep function, EC will not generate a beep sound when you press the front bezel button.

BIOS Menu location:

BIOS Menu – Advanced – IT5121 HW Monitor – Beep Sound Function

- Enable: There will be a Beep sound when the front bezel button is pressed. (Default)
- Disable: There will not be a beep sound when the front bezel button is pressed.

7. Setup Popup Menu F12

You can press the “F12” key to access the Setup popup menu during system boot.

When you press the “F12” key during bootup, BIOS will display a bootable device menu and you can select the boot device that you choose.

Chapter 10

Temporarily Disable
VMD for OS Image
Restoration

10.1 Introduction

The POC system supports a new generation of Intel® VMD Disk Controller. However, some old OS and tools cannot recognize this new controller. It may not detect the system internal NVME storage when you restore from the OS image.

The following description shows step-by-step how to disable VMD in BIOS.

1. Boot to the BIOS setup menu. (Press the Del or Esc key during system boot.)
2. In the BIOS menu - Chipset - System Agent (SA) Configuration - VMD setup menu

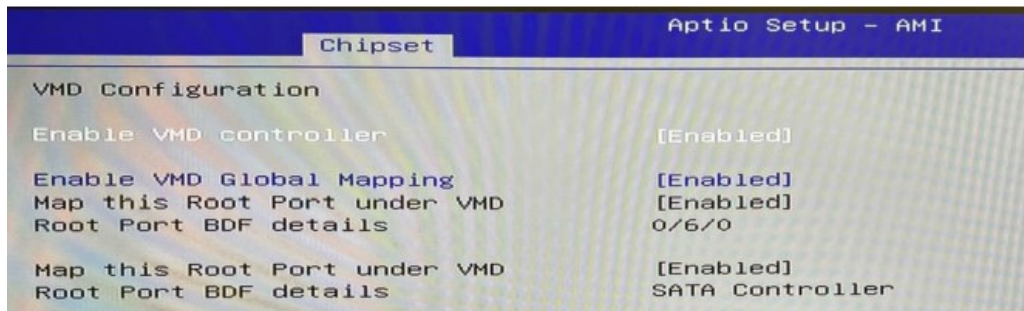

3. Change Enable VMD controller to Disabled.

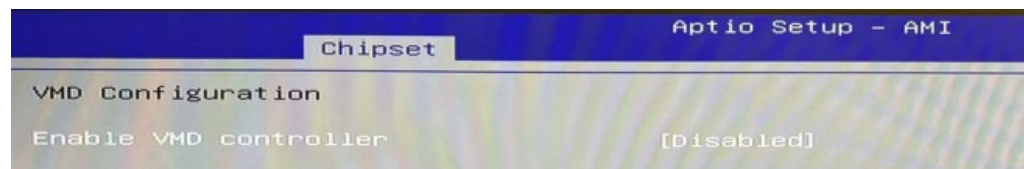

4. Save the settings and restart.
5. You can use OS restore tools, such as the GHOST tool to restore the OS image to the POC system.
6. After OS restoration is complete, please enable the VMD controller before OS boot.
Boot to the BIOS setup menu. (Press the Del or Esc key during system boot.)
7. In the BIOS menu - Chipset - System Agent (SA) Configuration - VMD setup menu
8. Set all four items to Enable

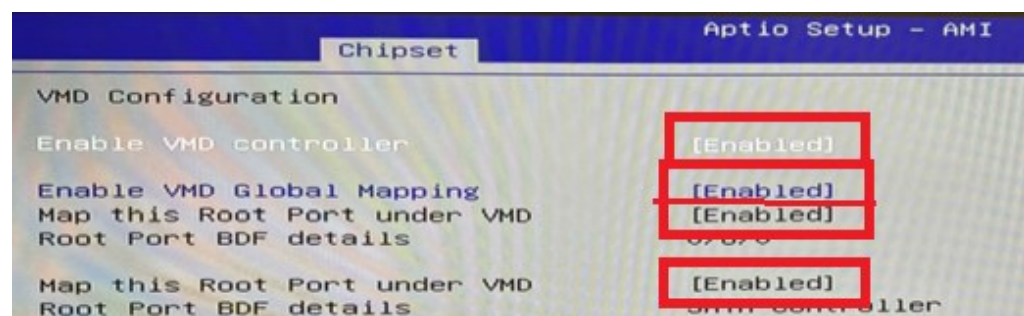

If the last two "Map this Root Port under VMD" items cannot be selected, you can set "Enable VMD Global Mapping" to Disable. The last two items will then be selectable.

Please set all the above four items to Enabled.

9. Save the settings and restart.

10. Boot your system to your OS image.

Caution! *If you do not enable the VMD controller in the BIOS, it could result in a failure during the OS bootup process.*



Chapter 11

Installing a PCIe Card

11.1 Installing a PCIe Card

The POC system contains one PCIe x4 slot for function expansion. The following section describes the relevant PCIe card installation information.

1. PCIe Card Dimensions

This slot supports a standard height 111.15mm (4.376 inches) card. Note that card height is measured from the bottom of the edge finger to the top of the card.

The card length limit is 168mm (6.6 inches).

The length over this limit might impact the reserved 2.5" SSD, causing it to not be able to be installed properly.

This PCIe x4 Card and internal backup battery module are mutually exclusive. You cannot install both modules in the same location.

Caution! Install a PCIe card with length shorter than 168mm.

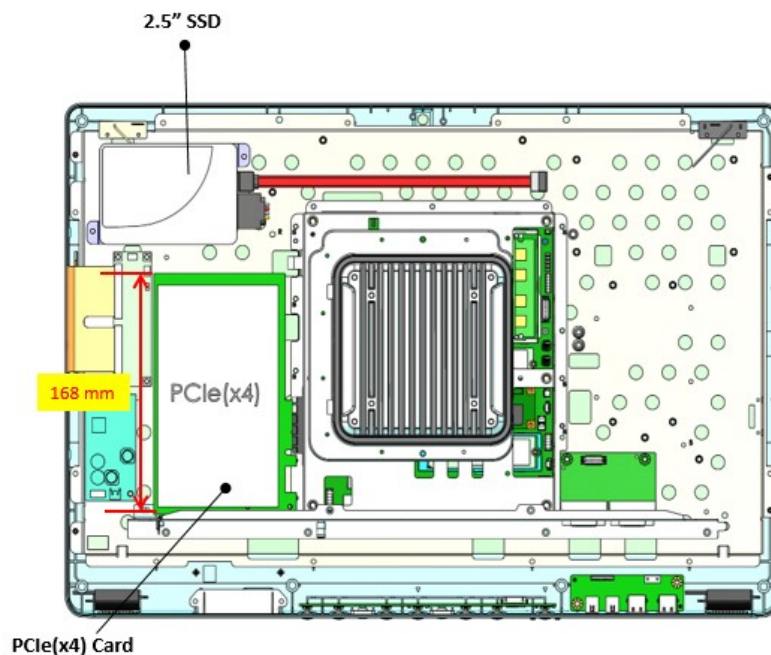

2. PCIe Card Power

Because the system cannot dissipate heat through enclosure vent holes, adding a high power/thermal PCIe card might cause overheating conditions.

Advantech recommends the PCIe card thermal dissipation should not exceed 5W.

The customer needs to consider the total thermal solution and if the card's thermal dissipation exceeds the above criteria. It may be necessary to add a fan or control the temperature of the environment through other means.

Warning User install high-power PCIe Card might cause the system to overheat. This may cause the system to shut down or restart.



3. PCIe Card Installation

The following section describes PCIe Card installation.

Warning *Because of the danger of electric shock, never remove the cover of a device while it is in operation or connected to a power outlet.*



11.1.1 Install PCIe(x4) Card

1. Remove the fixed bracket screw.

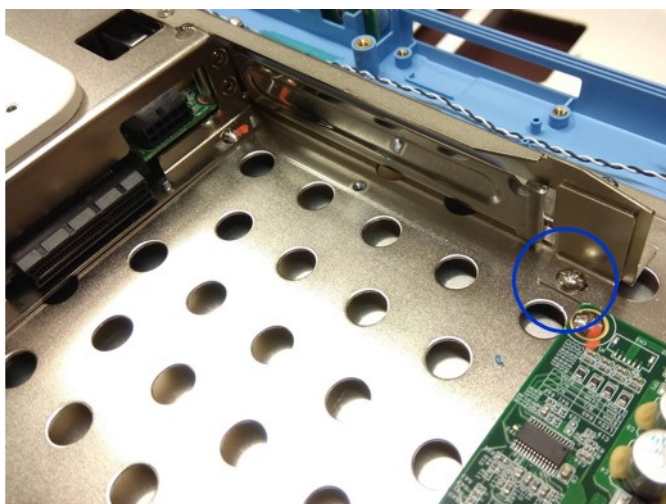

2. Remove the fixed bracket and dummy plate.

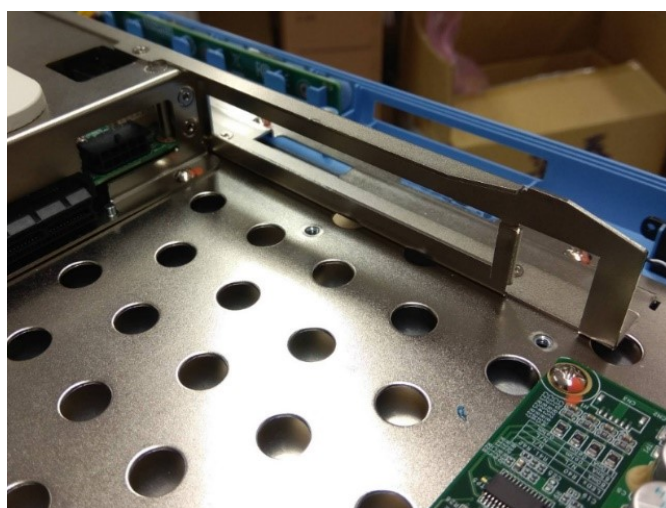

3. Install the PCIe (x4) card.

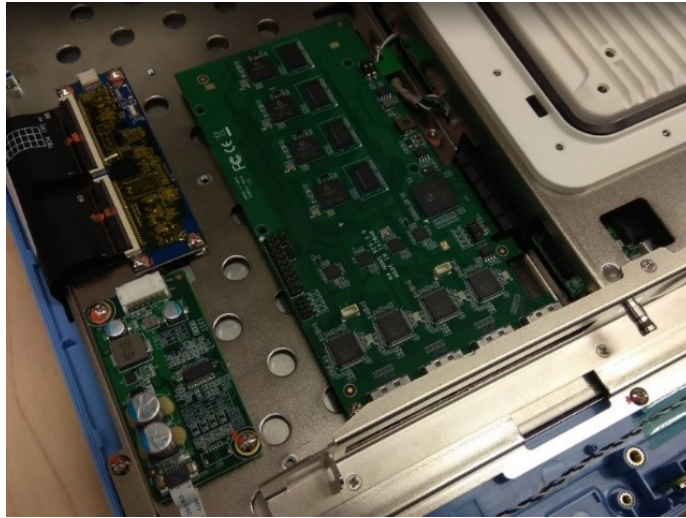

4. Install the fixed bracket with a screw and make sure the PCIe card does not move.

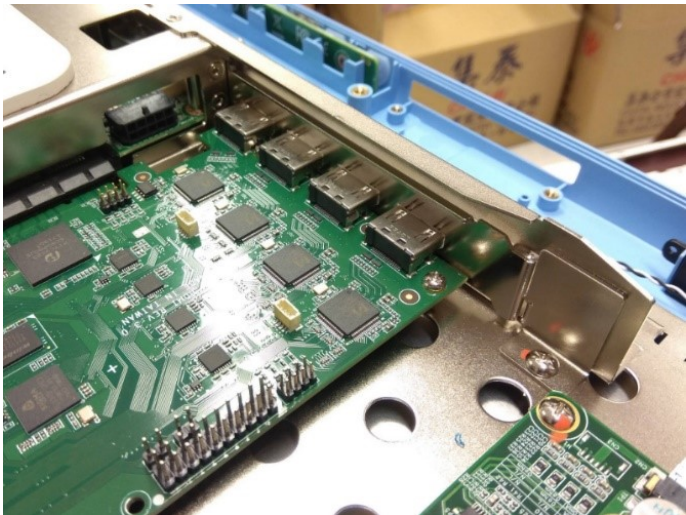

Chapter 12

Hot-Swap Battery Pack Operation

The POC device supports hot-swapping battery pack operation. Through hot-swapping, the user can hotplug install two battery packs. This chapter describes how to install and swap a battery.

12.1 Installing the Hot-Swap Battery Pack

1. Open the battery door:

Users can access the battery slot using the arrowhead buttons (circled in red below).

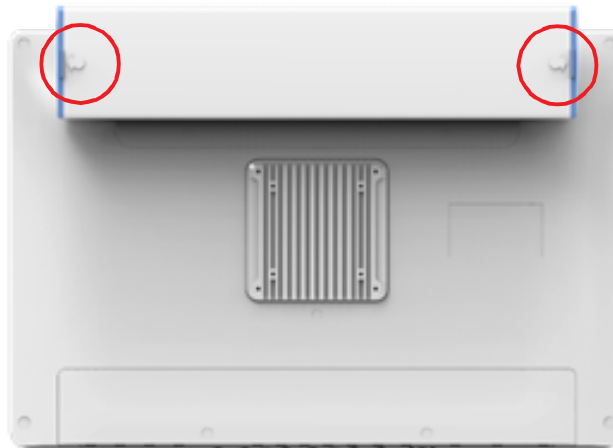

1) Press the arrowhead button.



2) Pull open the door to access the battery slot.



Caution! We recommend holding the battery with both hands when inserting it into the POC-621-12 power system.



2. Insert the battery pack:

The slot opening and battery packs feature notches (circled in red below) to indicate the correct installation direction.



Caution! Please hold the battery with both hands when installing the battery into the slot.



3. Close the battery door. When the door is fully closed, a “click” will be heard to ensure that the door is closed properly.



Warning! If not closed properly, the battery door may cause the battery to drop out.



Caution! Lay the pull ring and mylar (indicated in the image below) flat in their original positions before closing the door.



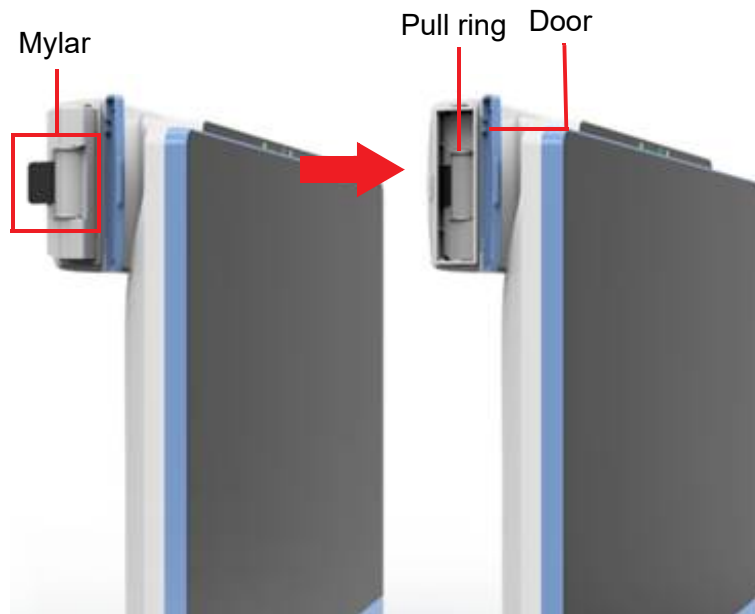

12.2 Battery Pack Capacity Indicator

The battery pack has a charge level indicator.

Press the button shown circled in red below. The battery pack will turn on the indicator to show its current amount of charge.



The illuminated LED represents the amount of charge.

	State-of-Charge
LED Green	<i>Current()</i> > 0
LED1	0%~20%
LED2	0~40%
LED3	0~60%
LED4	0~80%
LED5	0~100%

Hot-swapping battery pack charge level indicator and Windows battery Information

- Hot-swapping battery pack charge level indicator
The hot-swapping battery pack has an LED indicator to show the current charge level of the battery.



In Discharge mode, the indicator shows the following levels.

Table 12.1: Capacity	
Battery Charge Level	LED
0~10%	Flash 1 LED (0.5Hz Frequency)
11~20%	1 LED ON
21~50%	2 LED ON
51~100%	3 LED ON

In Charge mode, the indicator show the following capacity.

Table 12.2: Capacity	
Battery Charge Level	LED
0~20%	1 LED ON
21~50%	2 LED ON
51~100%	3 LED ON

These LED indicators are only ON when the POC system is turned ON. The LED indicator will turn off when the POC system is turned off. This setting can save battery life.

- Windows Battery Icon
When you click on the Windows battery icon, it will show each battery's charge level percentage and the dual battery's average charge level percentage.



Windows will gather each battery's charge level (unit: mAh) to calculate the charge level percentage.

Single battery charge level percentage =

$$\frac{\text{Battery remain capacity}}{\text{Battery full capacity}} * 100\%$$

Dual battery average charge level percentage =

$$\frac{\text{Battery 1 remain capacity} + \text{Battery 2 remain capacity}}{\text{Battery 1 full capacity} + \text{Battery 2 full capacity}} * 100\%$$

12.3 Regular Use of a Battery Pack

Below are instructions for maintaining a healthy battery:

1. Always fully charge new batteries before first use.
2. When battery capacity lower than the Windows low level setting (Default: 10%), Windows will display a low-battery notification. At this point, either replace the battery with a fully charged battery or plug in a power adapter to recharge the battery.
3. Prevent over-discharging the battery. Over discharging will significantly reduce the battery's shelf life.
4. If the POC system is not in use, turn off the system to save battery power.
5. If one battery is installed, the POC system can work.

12.4 Battery Pack Storage

If the POC system or battery pack is stored in a warehouse for a long duration, the following tasks must be performed:

1. Always fully charge new batteries before moving them to a warehouse.
2. Before storing the battery and leaving it idle, recharge the battery to full capacity.
3. If the battery is left unused or idle for a long duration, perform a full recharge every 3 months.
4. Ensure that the POC system is switched off and double check that the "power on" green LED indicator is off before storing the unit.

12.5 Battery Operation Sequence

When two batteries are installed, you should follow the below sequence to charge/discharge batteries.

1. Balanced mode (two batteries are of the same voltage):
Change or discharge the two batteries together.
2. Un-balanced mode (two batteries with different voltages):
Charge: Charge the low-voltage battery first. When these two batteries reach the same voltage, charge the two batteries together.
Discharge: Charge the high-voltage battery first. When these two batteries reach the same voltage, discharge the two batteries together.

ADVANTECH

Enabling an Intelligent Planet

www.advantech.com

Please verify specifications before quoting. This guide is intended for reference purposes only.

All product specifications are subject to change without notice.

No part of this publication may be reproduced in any form or by any means, electronic, photocopying, recording or otherwise, without prior written permission of the publisher.

All brand and product names are trademarks or registered trademarks of their respective companies.

© Advantech Co., Ltd. 2023