

W07IAN3S-GCT1

7-inch G-WIN GC-Series Front IP65 PCAP Panel PC with Intel® Processor N150



KEY FEATURES

- 7" 1024 x 600 with P-CAP touchscreen
- Low power consumption with Intel® Processor N150
- Fanless cooling system design
- Front IP65 for protection against water and dust
- A true flat, easy-to-clean front surface with edge-to-edge design
- Plenty of I/O, including 2 x 2.5GbE LAN, 1 x COM, 2 x USB 3.2 Gen 2 x1, 1 x HDMI

INTRODUCTION

Winmate G-WIN GC Series Panel PC Series offers advanced performance and flexibility, with sizes ranging from 7" to 24" and support for various operating systems, including Windows and Android. Designed with a fanless cooling system and ultra-low power consumption, these panel PCs feature a front IP65-rated edge-to-edge flat design for water and dust resistance and easy cleaning. With versatile I/O options, including USB, HDMI, and RS232/422/485, these robust devices are ideal for industrial automation, kiosks, and control systems, ensuring reliability in harsh environments.

SPECIFICATIONS

Display

Resolution	1024x600	Size	7.0 inches
Contrast Ratio	1000:1	Panel Brightness	320.0 nits
View Angles	75,75,75,70	Active Area	153.6x90 mm
Touch / Glass	Projected Capacitive Multi Touch Screen		

System Specification

Processor	Intel® Processor N150 6M Cache, up to 3.6 GHz	Memory	8GB(Default) (Default) 16GB (Optional)
Storage	128GB SSD(Default) (Default) 256GB SSD (Optional) 512GB SSD (Optional) 1TB (Optional) 2TB (Optional) 4TB (Optional)	Ethernet controller	2 x Intel® 2.5 Gigabit Ethernet Controller
Security	TPM 2.0	Operating System	Windows 11 IoT Enterprise (64 bit) (Optional) Windows 11 Pro 64 bit (Optional) Windows 10 IoT Enterprise (64 bit) (Optional) Linux Ubuntu 24.04 (Optional)
WLAN	(Optional)	BT	(Optional)

Environment

Operating Humidity	10% to 90% (Non-Condensing)	Operating Temperature	0~50°C
Storage Temperature	-30°C~70°C	Shock	MIL-STD-810G Method 516.6
Vibration	MIL-STD-810G Method 514.6	IP rating	Front IP65

Certification

Certification CE, FCC

IO Ports

USB Port	2 x USB3.2 Gen2 x 1 (Type-A) 1 x USB 3.2 Gen 2x1 Type C	Serial Port	1 x RS232(Default)/422/485 ((Default RS232)
Video	1 x HDMI 2.0b, Max resolution up to 4096x2160@60Hz (Optional) 1 x USB Type C ,support DP Alt. mode.Max resolution up to 4096 x 2160@60Hz	Audio	1 x Speaker
LAN	2 x 2.5 Giga LAN RJ45 Connector		

Mechanical

Dimension	189.4 x 145.4 x 39.8mm	Mounting	VESA mount (Default) Front IP65 Panel mount (Optional)
Enclosure	Metal Housing with Aluminum Bezel	Cooling System	Fanless Design

Accessory

Accessory	User Manual(Hardcopy) AC Adapter Power Cable
------------------	--

Power

Power Rating 12V DC in

Control

Button	1 x Power Button 1 x Reset Button
---------------	--------------------------------------

DIMENSIONS UNIT:MM

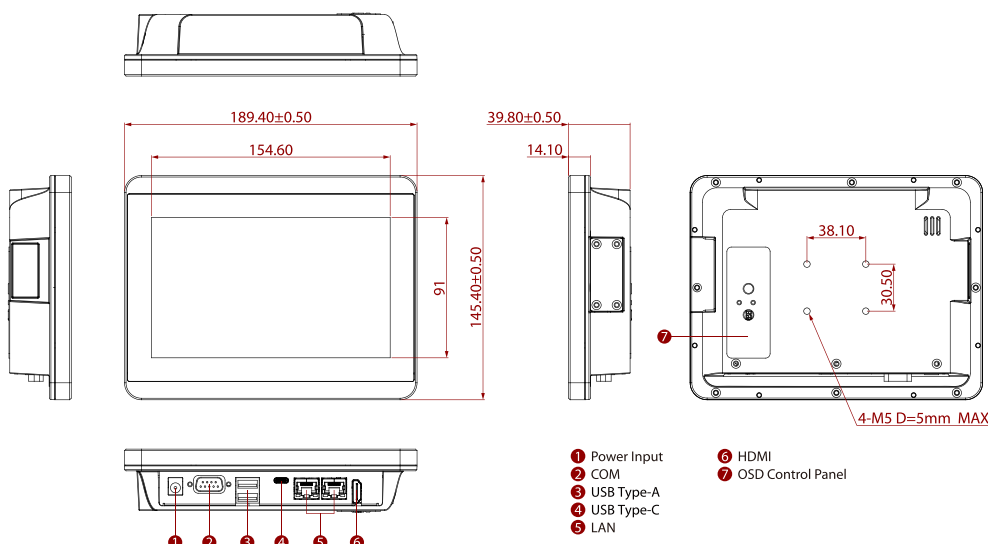

NOTE

1. This is a simplified drawing and some components are not marked in detail.
2. Please contact our sales representative if you need further product information.
3. All specifications are subject to change without prior notice.
4. The product shown in this datasheet is a standard model. For diagrams that contain customized or optional I/O, please contact the Winmate Sales Team for more information.