

APC-2146

21.5 Intel® 14th Gen. Meteor Lake Ultra 5 125U Processor
Light Multi-Touch Fanless Panel PC

Quick Reference Guide

1st Ed –15 April 2026

Copyright Notice

Copyright © 2026 Avalue Technology Inc., ALL RIGHTS RESERVED.

Document Amendment History

Revision	Date	By	Comment
1 st	April 2026	Avalue	Initial Release

Declaration of Conformity



This device complies with part 15 FCC rules. Operation is subject to the following two conditions:

(1) This device may not cause harmful interference.

(2) This device must accept any interference received including interference that may cause undesired operation.

This equipment has been tested and found to comply with the limits for a Class "A" digital device, pursuant to part 15 of the FCC rules.

These limits are designed to provide reasonable protection against harmful interference when the equipment is operated in a commercial environment. This equipment generates, uses, and can radiate radio frequency energy and, if not installed and used in accordance with the instruction manual, may cause harmful interference to radio communications.

Operation of this equipment in a residential area is likely to cause harmful interference in which case the user will be required to correct the interference at his own expense.

CE statement

The product(s) described in this manual complies with all application European Union (CE) directives if it has a CE marking. For computer systems to remain CE compliant, only CE-compliant parts may be used. Maintaining CE compliance also requires proper cable and cabling techniques.

Notice

This guide is designed for experienced users to setup the system within the shortest time. For detailed information, please always refer to the electronic user's manual.

Copyright Notice

© 2026 by Avalue Technology Inc. All rights are reserved. No parts of this manual may be copied, modified, or reproduced in any form or by any means for commercial use without the prior written permission of Avalue Technology Inc. All information and specification provided in this manual are for reference only and remain subject to change without prior notice.

Acknowledgements

Intel and Pentium are trademarks of Intel Corporation.

Microsoft Windows is registered trademark of Microsoft Corp.

All other product names or trademarks are properties of their respective owners.

Disclaimer

This manual is intended to be used as a practical and informative guide only and is subject to change without notice. It does not represent a commitment on the part of Avalue. This

product might include unintentional technical or typographical errors. Changes are periodically made to the information herein to correct such errors, and these changes are incorporated into new editions of the publication.

A Message to the Customer

Avalue Customer Services

Each and every Avalue's product is built to the most exacting specifications to ensure reliable performance in the harsh and demanding conditions typical of industrial environments. Whether your new Avalue device is destined for the laboratory or the factory floor, you can be assured that your product will provide the reliability and ease of operation for which the name Avalue has come to be known.

Your satisfaction is our primary concern. Here is a guide to Avalue's customer services. To ensure you get the full benefit of our services, please follow the instructions below carefully.

Technical Support and Assistance

1. Visit the Avalue website at <https://www.avalue.com/> where you can find the latest information about the product.
2. Contact your distributor or our technical support team or sales representative for technical support if you need additional assistance. Please have following information ready before you call:
 - Product name and serial number
 - Description of your peripheral attachments
 - Description of your software (operating system, version, application software, etc.)
 - A complete description of the problem
 - The exact wording of any error messages

To receive the latest version of the user's manual; please visit our Web site at:

www.avalue.com

Product Warranty (Returns & Warranties policy)

1. Purpose

Avalue establishes the following maintenance specifications and operation procedures for providing the best quality of service and shortened repair time to our customers.

2. Warranty

2.1 Warranty Period

Avalue endeavors to offer customers the most comprehensive post-sales services and protection; besides offering a 2-year warranty for standard Avalue products, an extended warranty service can also be provided based on additional request from the customer.

Within the warranty period, customers are entitled to receive comprehensive and prompt repair and warranty.

Standard products manufactured by Avalue are offered a 2-year warranty, from the date of delivery from Avalue. For ODM/OEM products manufactured by Avalue or PCBA with conformal coating, will follow up the define warranty of the agreement, otherwise will be offered 1-year warranty for ODM/OEM products but non-warranty for PCBA with conformal coating. For outsourcing parts kit by Avalue (ex: Motherboard, LCD touch panel, CPU, RAM, HDD) are offered a 6-month warranty, and Mobile/Tablet PC battery are offered a warranty of the half year, from the date of delivery by Avalue. Products before the mass production stage, i.e. engineering samples are not applied in this warranty or service policy. For extended warranty and cross-territory services, product defects resulting from design, production process or material are covered by the pre-set warranty period after the date of delivery from Avalue. For non-Avalue products, the product warranty and repair time shall be based on the service standards provided by the original manufacturer; in principle Avalue will provide these products a warranty service for no more than one year.

2.2 Maintenance services within the warranty period

In the case of Avalue product DOA (Defect-on-Arrival) when the customer finds any defect within 1 month after the delivery, Avalue will replace it with a new product in a soonest way. Except for custom products, once the customer is approved of a Cross-Shipment Agreement, which allows for delivery a new product to the customer before receiving the defective one, Avalue will immediately proceed with new product replacement for the said DOA case. On validation of the confirmed defect, Avalue is entitled to reserve the right whether to provide a new product for replacement. For the returned defective new product, it is necessary to verify that there shall be no bruise, alteration, scratch or marking to the appearance, and that none of the delivered accessories missing; otherwise, the customer will be requested to pay a processing fee. On the other hand, if the new product defect is resulting from incorrect configuration or erroneous use by the user instead of any problem of the hardware itself, the customer will also be requested to pay for relevant handling fees.

APC-2146

As for other conditions, Avalue will handle defects by way of repair. The customer will be requested to send the defective product to an Avalue authorized service center, and Avalue will return the repaired product back to the customer as soon as possible.

2.3 Ruling of an out-of-warranty defect

The following situations are not included in the warranty:

- The warranty period has expired.
- Product has been altered or its label of the serial number has been torn off.
- Product functionality issues resulting from improper use by the user, unauthorized dismantle or alteration, unfit operation environment, improper maintenance, accident or other causes. Avalue reserves the right for the ruling of the aforementioned situations.
- Product damage resulting from lightning, flood, earthquake or other calamities.
- The warranty rules of non-Avalue products and accessories shall be in accordance with standards set up by the original manufacturer. These products and accessories include RAM, HDD, FDD, CD-ROM, CPU, FAN, etc.
- Product upgrade request or test request submitted by the customer after expiration of the warranty.
- PCBA with conformal coating.
- Avalue semi-product and outsourced products without Avalue serial number.
- Products before the mass production stage, i.e. engineering samples.

3. Procedure for sending for repair

3.1 Attain a RMA number

A customer's rejected product returned for repair shall have a RMA (Return Merchandise Authorization) number. Without a RMA number, Avalue will not provide any repair service for the rejected product, and the product will be returned to the customer at customer's cost. Avalue will not issue any notice for the return of the product.

Each returned product for repair shall have a RMA number, which is simply the authorization of the return for repair; it is not a guarantee that the returned goods can be repaired or replaced. For applying for a RMA number, the customer may enter the eRMA webpage of Avalue <https://www.avalue.com/en/member> and log-in with an account number and a password authorized by Avalue. The system will then automatically issue a RMA number.

When applying for the RMA number, it is essential to fill in basic information of the customer and the product, together with detailed description of the problem encountered. If possible, avoid using ambiguous words such as "does not work" or "problematic". Without a substantial description of the problem, it is hard to start the repair and will cause prolonged repair time. Lacking detailed statement of fault steps also makes the problem hard to be identified, sometimes resulting in second-time repairs.

In case the customer can't define the cause of problem, please contact Avalue application engineers. Sometimes when the problem can be resolved even before the customer sends back the product.

On the other hand, if the customer only returns the key parts to Avalue for repair, it is necessary that the serial number of the entire unit is given in the "Problem Description" field, so that warranty period can be ruled accordingly; or Avalue will handle the case as an Out-of- warranty case.

3.2 Return of faulty product for repair

It is recommended that the customer not to return the accessories (manual, connection cables, etc.) with the products for repair, devices such as CPU, DRAM, CF memory card, etc., shall also be removed from the faulty goods before return for repair. If these devices are relevant to described repair problems and necessary to be returned with the goods; please clearly indicate the items included in the eRMA application form. Avalue shall not be responsible for any item that is not itemized. Moreover, make sure the problem(s) are detailed in the "Problem Description" field.

In the list of delivery, the customer may fill-in a value which is lower than the actual value, to prevent customs levying a higher tax over the excessive value of the return goods. The customer shall be held responsible for extra fees caused by this. We strongly recommend that "Invoice for customs purpose only with no commercial value" be indicated on the delivery note. Also for the purpose of expedited handling, please printout the RMA number and put it in the carton, also indicate the number outside of the carton, with the recipient addressing to Avalue RMA Department.

When returning the defective product, please use an anti-static bag or ESD material to pack it properly. In case of improper packing resulting in damages in the transportation process, Avalue reserves the right to reject the un-repaired faulty good at the customer's costs. Furthermore, it is suggested that the faulty goods shall be sent via a door-to-door courier service. The customer shall be held responsible for any customs clearance fee or extra expenses if Air-Cargo is used for the delivery.

In case of a DOA situation of a new product, Avalue will be responsible for the product and the freight. If the faulty goods are within the warranty period, the sender will take responsibility for the freight. For an out-of-warranty case, the customer shall be responsible for the freight of both trips.

3.3 Maintenance Charge

Avalue will charge a moderate repair fee for the following conditions:

- The warranty period has expired.
- Product has been altered or its label of the serial number has been torn off.
- Product functionality issues resulting from improper use by the user, unauthorized dismantle or alteration, unfit operation environment, improper maintenance, accident

or other causes. Avalue reserves the right for the ruling of the aforementioned situations.

- Product damage resulting from lightning, flood, earthquake or other calamities.
- The warranty rules for non-Avalue products and accessories shall be in accordance with standards set up by the original supplier. These products and accessories include RAM, HDD, FDD, CD-ROM, CPU, FAN, etc.
- Product upgrade request or test request submitted by the customer after expiry of the warranty.
- PCBA with conformal coating.
- Avalue semi-product and outsourced products without Avalue serial number
- Products before the mass production stage, i.e. engineering samples.
- In case the products received are examined as NPF (No Problem Found) within the warranty period, the customer shall be responsible for the freight of both trips.
- Please contact your local distributor to examine in advance to prevent unnecessary freight cost.

For system failure of out-of-warranty products, Avalue will provide a quotation prior to repair service. When the customer applies for the cost, please refer to the Quotation number. In case the customer does not return the DOA product that has already been replaced by a new one, or the customer does not sign back the quotation of the out-of-warranty maintenance, Avalue reserves the right of whether or not to provide the repair service. In case the customer does not reply in 3 months, Avalue shall directly scrap or return the product back to customer at customer's cost without further notice to the customer.

3.4 Maintenance service of phased-out products

For servicing phased-out products, Avalue provides an extended period, starting the date of phase-out, as a guaranteed maintenance period of such products, for continuance of the maintenance service to meet customer's requirements. In case of unexpected factors causing Avalue to be unable to repair/replace a warranted but phased-out product, Avalue will, depending on the availability, upgrade the product (free of charge with continued warranty period as of the original product), or, give partial refund (based on the length of the remaining warranty period) to solve this kind of problem.

3.5 Maintenance Report

On completion of repair of a defective product, a Maintenance Report indicating the maintenance result and part(s) replaced (if any) will be sent to the customer together with the product. If the customer demands an additional maintenance analysis report, a service fee of various level will be charged depending on the warranty status. In case the analysis result shows that the defect attributes to Avalue's faulty design or process, the analysis fee will be exempted.

4. Service Products

Avalue provides service products to manage with different customer needs. Should you have any need, please consult to Avalue Sales Department.

Defect Analysis Report (DAR)

Avalue provides DAR (Defect Analysis Report) services aiming to elevating customer satisfaction. A DAR includes defect cause identification/verification/suggestion and improvement precautions, with instructions on correct usage for the avoidance of any reoccurrence.

Upgrade Service

Avalue is capable to provide system upgrade service for customization requirements. This upgrade service is applicable for main parts, such as CPU, memory, HDD, SSD, storage devices; also replacements motherboards of systems. Please contact Avalue sales for details to evaluate the possibility of system upgrade service and obtain information of lead time and price.

Safety Instructions

Safety Precautions

Before installing and using this device, please note the following precautions.

1. Read these safety instructions carefully.
2. Keep this User's Manual for future reference.
3. Disconnected this equipment from any AC outlet before cleaning.
4. For plug-in equipment, the power outlet socket must be located near the equipment and must be easily accessible.
5. Keep this equipment away from humidity.
6. Put this equipment on a reliable surface during installation. Dropping it or letting it fall may cause damage.
7. Make sure the voltage of the power source is correct before connecting the equipment to the power outlet.
8. Use a power cord that has been approved for using with the product and that it matches the voltage and current marked on the product's electrical range label. The voltage and current rating of the cord must be greater than the voltage and current rating marked on the product.
9. Position the power cord so that people cannot step on it. Do not place anything over the power cord.
10. All cautions and warnings on the equipment should be noted.
11. If the equipment is not used for a long time, disconnect it from the power source to

APC-2146

avoid damage by transient overvoltage.

12. Never pour any liquid into an opening. This may cause fire or electrical shock.











13. Never open the equipment. For safety reasons, the equipment should be opened only by qualified service personnel. If one of the following situations arises, get the equipment checked by service personnel:







- The power cord or plug is damaged.
- Liquid has penetrated into the equipment.
- The equipment has been exposed to moisture.
- The equipment does not work well, or you cannot get it work according to the user's manual.
- The equipment has been dropped and damaged.
- The equipment has obvious signs of breakage.

14. **CAUTION:** Danger of explosion if battery is incorrectly replaced. Replace only with the same or equivalent type recommended by the manufacturer.

15. Equipment intended only for use in a **RESTRICTED ACCESS AREA**.

Explanation of Graphical Symbols

	Warning	A WARNING statement provides important information about a potentially hazardous situation which, if not avoided, could result in death or serious injury.
	Caution	A CAUTION statement provides important information about a potentially hazardous situation which, if not avoided, may result in minor or moderate injury to the user or patient or in damage to the equipment or other property.
	Note	A NOTE provides additional information intended to avoid inconveniences during operation.
		Direct current.
		Alternating current
		Stand-by, Power on
		FCC Certification
		CE Certification
		Follow the national requirements for disposal of equipment.
		Stacking layer limit
		This side up

		<p>Fragile Packaging</p>
		<p>Beware of water damage, moisture-proof</p>
		<p>Carton recyclable</p>
		<p>Handle with care</p>
		<p>Follow operating instructions or consult instructions for use.</p>
		<p>WARNING</p> <ul style="list-style-type: none"> ● INGESTION HAZARD: This product contains a button cell or coin battery. ● DEATH or serious injury can occur if ingested. ● A swallowed button cell or coin battery can cause Internal Chemical Burns in as little as 2 hours. ● KEEP new and used batteries OUT OF REACH of CHILDREN. ● Seek immediate medical attention if a battery is suspected to be swallowed or inserted inside any part of the body.

Disposing of your old product

WARNING:

There is danger of explosion if the battery is mishandled or incorrectly replaced. Replace only with the same type of battery. Do not disassemble it or attempt to recharge it outside the system. Do not crush, puncture, dispose of in fire, short the external contacts, or expose to water or other liquids. Dispose of the battery in accordance with local regulations and instructions from your service provider.

CAUTION:

- Lithium Battery Caution: Danger of explosion if battery is incorrectly replaced. Replace only with same or equivalent type. Dispose batteries according to manufacturer's instructions.
- Disposal of a BATTERY into fire or a hot oven, or mechanically crushing or cutting of a BATTERY, that can result in an EXPLOSION
- Leaving a BATTERY in an extremely high temperature surrounding environment that can result in an EXPLOSION or the leakage of flammable liquid or gas.
- A BATTERY subjected to extremely low air pressure that may result in an EXPLOSION or the leakage of flammable liquid or gas.

Mise en garde!

AVERTISSEMENT : Il existe un risque d'explosion si la batterie est mal manipulée ou remplacée de manière incorrecte. Remplacez uniquement par le même type de batterie. Ne le démontez pas et ne tentez pas de le recharger en dehors du système. Ne pas écraser, percer, jeter au feu, court-circuiter les contacts externes ou exposer à l'eau ou à d'autres liquides. Jetez la batterie conformément aux réglementations locales et aux instructions de votre fournisseur de services.

MISE EN GARDE:

- Pile au lithium Attention : Danger d'explosion si la pile n'est pas remplacée correctement. Remplacer uniquement par un type identique ou équivalent. Jetez les piles conformément aux instructions du fabricant.
- L'élimination d'une BATTERIE dans le feu ou dans un four chaud, ou l'écrasement ou le découpage mécanique d'une BATTERIE, pouvant entraîner une EXPLOSION
- Laisser une BATTERIE dans un environnement à température extrêmement élevée pouvant entraîner une EXPLOSION ou une fuite de liquide ou de gaz inflammable.
- UNE BATTERIE soumise à une pression d'air extrêmement basse pouvant entraîner une EXPLOSION ou une fuite de liquide ou de gaz inflammable.

Content

1. Getting Started	17
1.1 Safety Precautions	17
1.2 Packing List	17
1.3 System Specifications	19
1.4 System Overview	23
1.4.1 I/O View	23
1.5 System Dimensions	24
2. Hardware Configuration	25
2.1 Powering On the System	26
2.2 EMX-MTLP Product Overview	27
2.3 EMX-MTLP Jumper and Connector List	28
2.4 EMX-MTLP Jumpers & Connectors settings	30
2.4.1 Clear CMOS (JCMOS1)	30
2.4.2 AT/ATX Power Mode Select (JAT1)	30
2.4.3 M.2 KeyB power selector (JM2BP1)	31
2.4.4 COM1 pin9 signal selector (JCOM1_PW1)	31
2.4.5 LVDS Backlight Power Select (JBLS1)	32
2.4.6 LVDS Backlight connector (JBL1)	32
2.4.7 SATA Power connector (JSPWR1)	33
2.4.8 Amplifier Wafer (SPK1)	33
2.4.9 ESPI Debug Header (JESPI1)	34
2.4.10 Serial port 1 connector (JCOM1)	34
2.4.11 Serial port 2 connector (JCOM2)	35
2.4.12 RTC Battery connector (BT1)	35
2.4.13 Serial Port 1 RS485/422 Mode connector (J485-1)	36
2.4.14 USB2.0 connector (JUSB2)	36
2.4.15 USB2.0 connector (JUSB3)	37
2.4.16 JPD connector (JPD1)	37
2.4.17 Front Panel connector (JFP1)	38
2.4.18 LVDS connector (JLVDS1)	38
2.4.19 EC_Program (JEC_1)	39
2.4.20 BIOS SPI connector (JBIOS1)	39
3. Installation	40
3.1 Installing Storage	42
3.2 System Mounting	43

4. Drivers Installation.....	44
4.1 Install Chipset Driver	45
4.2 Install VGA Driver.....	46
4.3 Install ME Driver.....	47
4.4 Install Audio Driver	48
4.5 Install Serial IO Driver	49
4.6 Install Ethernet Driver.....	51
4.7 Install Smart Sound Technology (ISST) Driver.....	52
4.8 Install Intel@NPU Driver	54
5. BIOS Setup	56
5.1 Introduction	57
5.2 Starting Setup	57
5.3 Using Setup	58
5.4 Getting Help	59
5.5 In Case of Problems.....	59
5.6 BIOS setup.....	60
5.6.1 Main Menu.....	60
5.6.1.1 System Language	61
5.6.1.2 System Date.....	61
5.6.1.3 System Time	61
5.6.2 Advanced Menu.....	62
5.6.2.1 Connectivity Configuration	62
5.6.2.2 CPU Configuration	63
5.6.2.2.1 Efficient-core Information	64
5.6.2.2.2 Performance-core Information	64
5.6.2.3 Power & Performance	65
5.6.2.3.1 CPU - Power Management Control.....	65
5.6.2.4 System Agent (SA) Configuration	66
5.6.2.4.1 Memory Configuration	67
5.6.2.4.2 Graphics Configuration.....	67
5.6.2.4.3 VMD setup menu.....	68
5.6.2.5 PCIE Configuration.....	68
5.6.2.5.1 PCI Express Root Port PXPA3(M.2 KeyE)	69
5.6.2.5.2 PCI Express Root Port PXPB1(M.2 KeyB)	70
5.6.2.5.3 PCI Express Root Port PXPB3(LAN1-I226).....	71
5.6.2.5.4 PCI Express Root Port PXPB4(LAN2-I226).....	72
5.6.2.5.5 PCI Express Root Port PXPC(PCIE slot).....	73
5.6.2.5.6 PCI Express Root Port PXPD(M.2 KeyM1)	74
5.6.2.5.7 PCI Express Root Port PXPE(M.2 KeyM2).....	75
5.6.2.6 PCH-IO Configuration	76

APC-2146

5.6.2.6.1	SATA Configuration.....	76
5.6.2.6.2	HD Audio Configuration	77
5.6.2.7	PCH-FW Configuration.....	77
5.6.2.7.1	Firmware Update Configuration	78
5.6.2.8	Trusted Computing.....	78
5.6.2.9	ACPI Settings	79
5.6.2.10	Board & Panel Configuration.....	79
5.6.2.10.1	SHOW DMI INFO	80
5.6.2.11	EC 5782 HW monitor	81
5.6.2.12	S5 RTC Wake Settings	81
5.6.2.13	Serial Port Console Redirection	82
5.6.2.14	USB Configuration.....	82
5.6.2.15	Network Stack Configuration.....	83
5.6.2.16	NVMe Configuration	84
5.6.3	Security	84
5.6.3.1	Security Boot	85
5.6.3.1.1	Expert Key Management.....	85
5.6.4	Boot	86
5.6.5	Save and Exit.....	87
5.6.5.1	Save Changes and Reset.....	87
5.6.5.2	Discard Changes and Reset.....	87
5.6.5.3	Restore Defaults	87
5.6.5.4	UEFI: InnostorInnoston 1.00, Partition 1 (Innoston Innoston 1.00)	87
5.6.6	MEBx	88
6.	Maintenance & Troubleshooting.....	89
7.	Product Application	95
8.	Operating the Device	96

1. Getting Started

1.1 Safety Precautions

Warning!



Always completely disconnect the power cord from your chassis whenever you work with the hardware. Do not make connections while the power is on. Sensitive electronic components can be damaged by sudden power surges. Only experienced electronics personnel should open the PC chassis.

Caution!



Always ground yourself to remove any static charge before touching the CPU card. Modern electronic devices are very sensitive to static electric charges. As a safety precaution, use a grounding wrist strap at all times. Place all electronic components in a static-dissipative surface or static-shielded bag when they are not in the chassis.

1.2 Packing List

Before installation, please ensure all the items listed in the following table are included in the package.

Item	Description	Q'ty
1	APC-2146 Panel PC	1
2	90W Power Adapter	1
3	VESA M4*6 Screw	4
4	HDD M3*4 Screw	4



If any of the above items is damaged or missing, contact your retailer.

Purposes and Applications

APC-2146 is a lightweight, all-in-one, multifunctional point-of-sale (POS) system with a 21.5" Full HD touchscreen, available in black or white. It provides a modern look coupled with simple, ergonomic and space-saving features. The APC-2146 supports Windows 10/11 and Linux.

Unpacking

Note:

If any of the components listed in the checklist below are missing, do not proceed with the installation. Contact the Avalue reseller or vendor the product was purchased from or contact an Avalue sales representative directly by sending an email to sales@avalue.com

To unpack the flat bezel panel PC, follow the steps below.

WARNING!

The front side LCD screen has a protective plastic cover stuck to the screen. Only remove the plastic cover after the fiat bezel panel PC has been properly installed. This ensures the screen is protected during the installation process.

Step 1: Carefully cut the tape sealing the box. Only cut deep enough to break the tape.

Step 2: Open the outside box.

Step 3: Carefully cut the tape sealing the box. Only cut deep enough to break the tape.

Step 4: Open the inside box.

Step 5: Lift the panel PC out of the boxes.

Step 6: Remove the peripheral parts box from the main box.

1.3 System Specifications

Component	
SBC	EMX-MTLP
Processor	Ultra 5 125U
CPU Cooler (Type)	Passive
System Memory	1 x 262-Pin DDR5 5600MHz SO-DIMM Socket Supports Up to 32GB
System Fan	Fanless
H/W Status Monitor	CPU Temperature Monitoring Voltage Monitoring
TPM	TPM 2.0
Speaker	2x SPK 4ohm 2W
Wireless LAN	Optional Intel AX210 Wi-Fi + Bluetooth 5.0 USB Module
Bluetooth	Optional Intel AX210 Wi-Fi + Bluetooth 5.0 USB Module
Operating System	Windows 11 LTSC 64bit, Linux Ubuntu
Expansion Card	1 x M.2 Key E 2230 support WiFi module
Front Touch/OSD board	No functional keys on the front touch
Storage	
Solid State Drive	2.5" SATA3 SSD
Panel	
LCD Panel	21.5" 1920 x 1080 TFT LCD panel Prolonged operation in environments exceeding 30°C may shorten the lifespan of the display panel
LCD Control Board	DB-LDA001-4-043
Touch Screen	21.5" 10-point multi-touch PCAP
Touch Controller	EETI EXC84H5680
Rear I/O	
USB Port	1 x USB Type C , support USB3.2 Gen2x2 (20G) 2 x USB3.2 Gen2 2 x USB3.2 Gen1
Video Port	1 x HDMI
Audio Port	1 x line-out, 1 x MIC-in
LAN Port	1 x Intel® i226LM 2.5 Gigabit Ethernet Controller 1 x Intel® i226V 2.5 Gigabit Ethernet Controller
LAN Port LED Indicator	

	Max. 1G LAN Port			
	ACT/LINK		SPEED	
	LED	Definition	LED	Definition
	Light Off	No Link	Solid Orange	1G
	Solid Yellow	Connection	Solid Green	100M
	Yellow Flashing	Activity	Light Off	10M
	Max. 2.5G LAN Port			
	ACT/LINK		SPEED	
		Definition	LED	Definition
	Light Off	No Link	Solid Orange	2.5G
Solid Yellow	Connection	Solid Green	1G/100M	
Yellow Flashing	Activity	Light Off	10M	
Wireless LAN Antenna	2 x PCB Antenna for WiFi			
Switch	Power switch			
Indicator Light	1 x Power LED			
DC in Connector	DC in Jack			
Power Requirement				
DC Input Voltage	DC Input 12-24V			
Power Mode	ATX(Default) / AT			
Power Button	1 x Power button			
Wake on Mode	Wake on LAN (specify condition, ex. S3/S4/S5/G3) Wake on RTC, Wake on Ring			
Power Connector Type	DC Plug with lock			
Power Adapter	AC/DC adapter 24V/3.75A PWR DIN Plug FSP FSP090-AABN3 (ACC-ADP-090N-06R)			
Mechanical				
Dimension	539.6 x 342.6 x 45.2 mm			
Weight	5.5 kg			
Construction- Front	Black Plastic			
Construction- Rear	Black Plastic			
Thermal Solution	Fanless			
Reliability				
Dust and Rain Test	Front IP65			
Vibration Test	Random Vibration Operation Reference IEC60068-2-64 Testing procedures Test Fh : Vibration boardband random Test 1 Test PSD : 0.00454G ² /Hz , 1.5 Grms			

	<p>2 Test frequency : 5~500 Hz 3 Test axis : X,Y and Z axis 4 Test time : 30 minutes each axis 5 System condition : operation mode 6 Test curve</p> <p>Sine Vibration Test Reference IEC60068-2-6 Testing procedures Test Fc : Vibration sinusoidal 1 Test Acceleration : 2G 2 Test frequency : 5~500 Hz 3 Sweep : 1 Oct/ per one minute. (logarithmic) 4 Test axis : X,Y and Z axis 5 Test time :30 min. each axis 6 System condition : Non-Operating mode 7 Test curve</p> <p>Package Vibration Test: Reference IEC60068-2-64 Testing procedures Test Fh : Vibration boardband random Test 1 Test PSD : 0.026G²/Hz , 2.16 Grms 2 Test frequency : 5~500 Hz 3 Test axis : X,Y and Z axis 4 Test time : 30 minutes each axis 5 Test curve</p>
<p>Mechanical Shock Test</p>	<p>1 Wave from : Half Sine wave 2 Acceleration Rate : 10g 3 Duration Time : 11ms 4 No. of shock : Z axis 300 times 5 Test Axis : Z axis 6 operation mode 7 Reference IEC 60068-2-27 testing procedures Test Eb : Shock Test</p>
<p>Drop Test</p>	<p>Package drop test Reference ISTA 2A, Method : IEC-60068-2-32 Test:Ed Test Ea : Drop Test 1 Test phase : One corner, three edges, six faces 2 Test high : 96.5cm 3 Package weight : 5Kg 4 Test drawing</p>

APC-2146

Operating Temperature	0°C ~ 40°C (32°F ~ 104°F) air flow 0.5
Operating Humidity	40°C @ 95% Relative Humidity, Non-condensing
Storage Temperature	-10°C ~ 60°C (14°F ~ 140°F)



Note: Specifications are subject to change without notice.

1.4 System Overview

1.4.1 I/O View

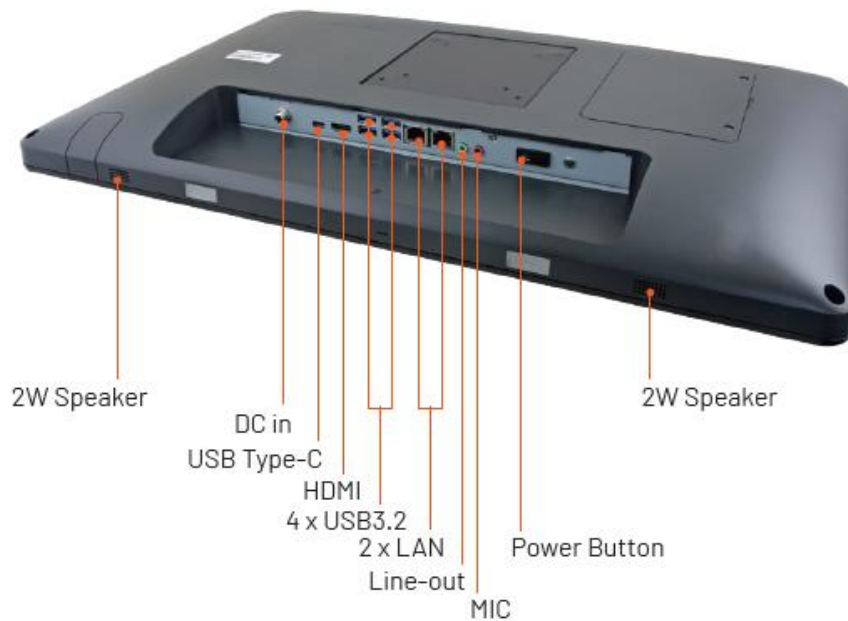

Connectors

Label	Function	Note
Power Button	Power on button	
2W Speaker	2 x 2W Speaker	
USB3.2	4 x USB 3.2 connector	
MIC	Mic-in audio jack	
Line-out	Line-out audio jack	
DC in	DC power-in connector	
LAN	2 x RJ-45 Ethernet	
HDMI	HDMI connector	
USB Type-C	USB Type-C connector	

1.5 System Dimensions

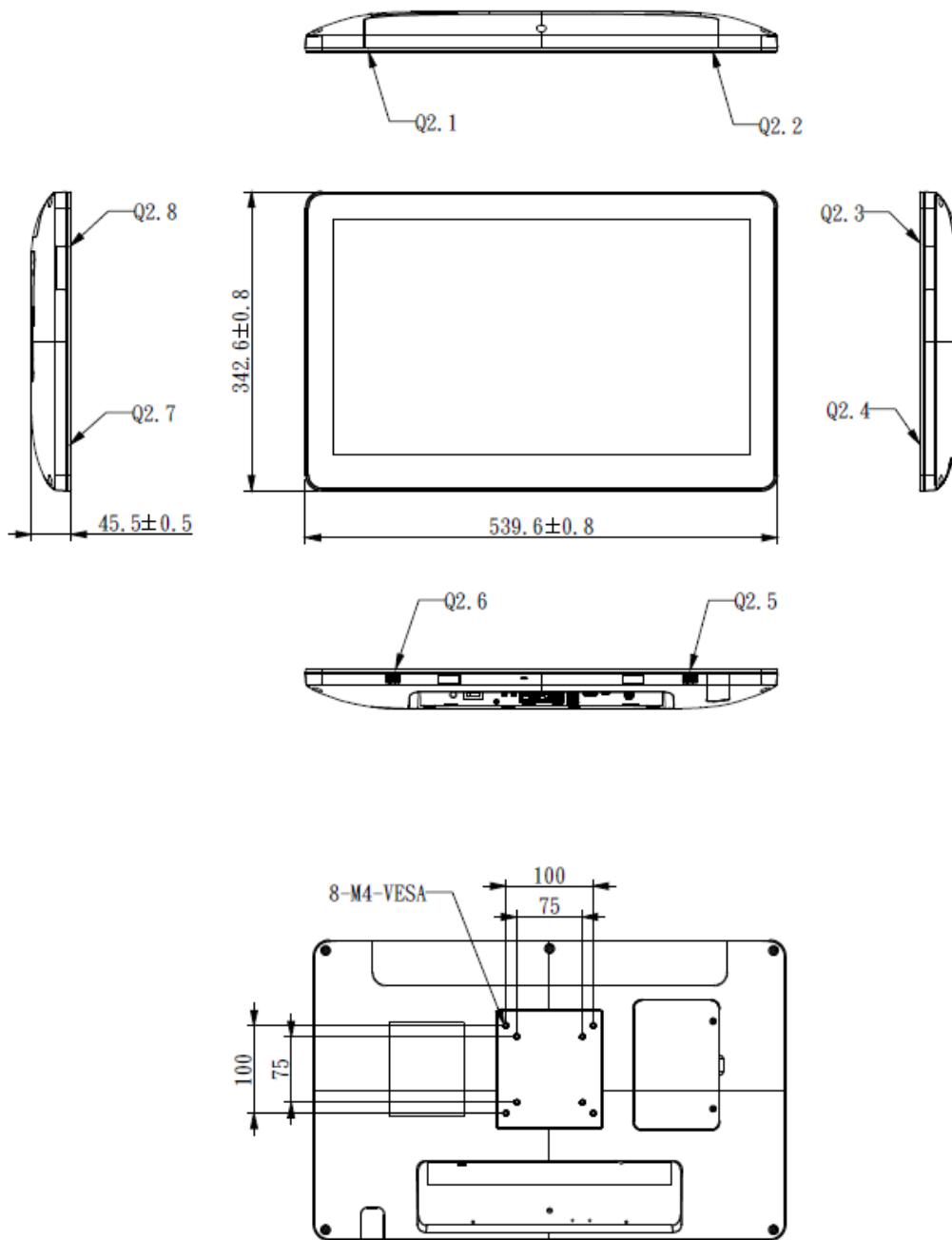

(Unit: mm)

2. Hardware Configuration

For advanced information, please refer to:

- 1- EMX-MTLP included in this manual.



Note: If you need more information, please visit our website:

www.avalue.com

2.1 Powering On the System

To power on the system, follow the steps below.

Step 1: Connect the power cord to the power adapter. Connect the other end of the power cord to a power source. Ensure to connect the power cord to a socket-outlet with earthing connection.

Step 2: Connect the power adapter to the power connector of the product.

Step 3: Locate the power button on the product.

Step 4: Switch on the power button can turn on the system. Keep holding the power button on can force shutdown the PC.

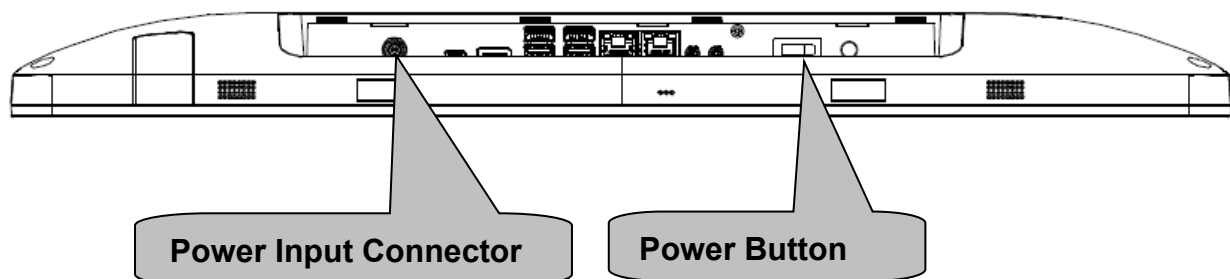

2.2 EMX-MTLP Product Overview

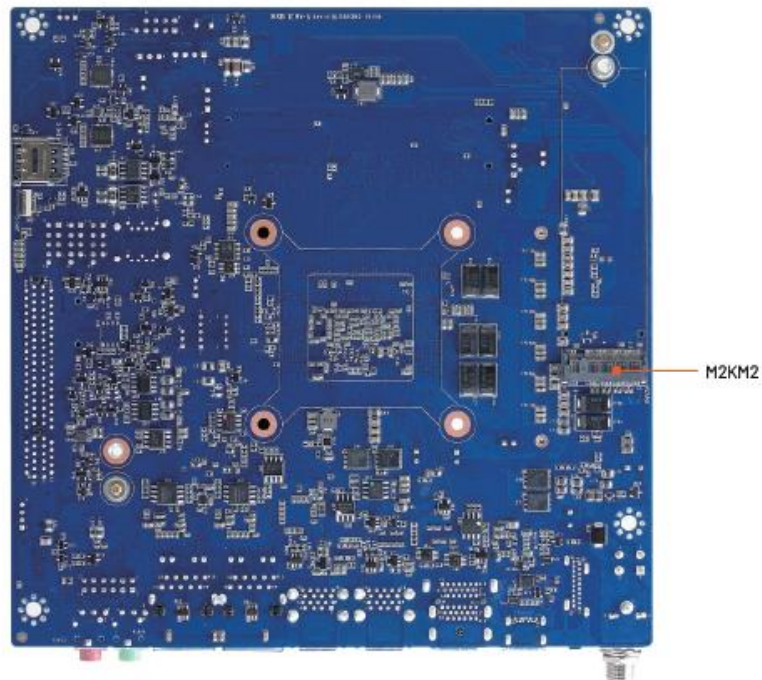
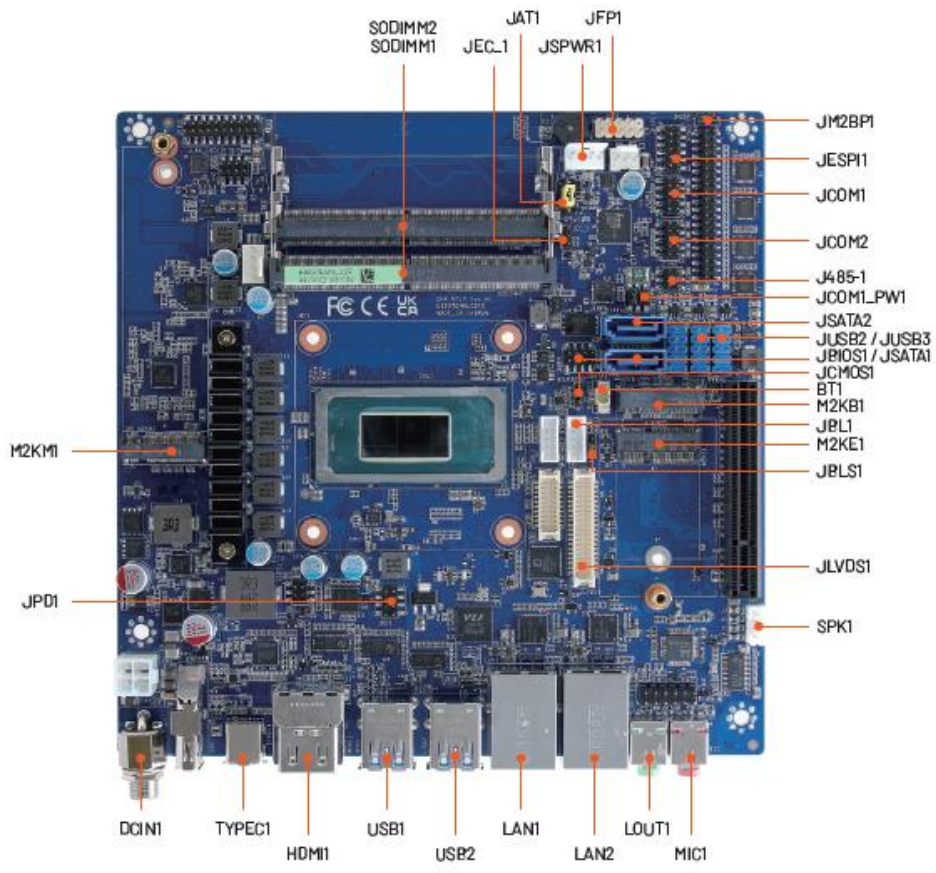

2.3 EMX-MTLP Jumper and Connector List

Jumpers

Label	Function	Note
JCMOS1	Clear CMOS	3 x 1 header, pitch 2.00mm
JAT1	AT/ATX Power Mode Select	3 x 1 header, pitch 2.54mm
JM2BP1	M.2 KeyB power selector	3 x 1 header, pitch 2.00mm
JCOM1_PW1	COM1 pin9 signal selector	3 x 2 header, pitch 2.00mm
JBLS1	LVDS Backlight Power Select	3 x 1 header, pitch 2.00mm

Connectors

Label	Function	Note
JBL1	LVDS Backlight connector	5 x 1 wafer, pitch 2.00mm Note: Matching connector: JST PHR-5
SODIMM1/2	2x 260-pin DDR5 5600MTs SO-DIMM Socket Supports Up to 64GB	
JSPWR1	SATA Power connector	4 x 1 wafer, pitch 2.54mm
SPK1	Amplifier Wafer	4 x 1 wafer, pitch 2.00mm
JESPI1	ESPI Debug Header	6 x 2 header, pitch 2.00mm
BT1	RTC Battery connector	2 x 1 wafer, pitch 1.25mm
JCOM1	Serial port 1 connector	5 x 2 header, pitch 2.00mm
JCOM2	Serial port 2 connector	5 x 2 header, pitch 2.00mm
J485-1	Serial Port 1 RS485/422 Mode connector	3 x 2 header, pitch 2.00mm
JUSB2/3	USB2.0 connector 2/3	5 x 2 header, pitch 2.54mm
JPD1	JPD connector	4 x 2 header, pitch 2.00mm
JFP1	Front Panel connector	5 x 2 header, pitch 2.54mm
JBIOS	BIOS SPI connector	4 x 2 header, pitch 2.00mm
JEC_1	EC_Program	3 x 1 header, pitch 2.00mm
JLVDS1	LVDS connector	20 x 2 wafer, pitch 1.25mm Note: Matching connector: Hirose DF-40DS-1.25C
M2KM1	M.2 2280 TYPE M Slot	
M2KM2	M.2 2280 TYPE M Slot	
M2KB1	M.2 2242/3042/3052 Type B Slot	
M2KE1	M.2 2230 Type E Slot	

JSATA1/2	Serial ATA connector 1/2
DCIN1	12~24V Power connector
TYPEC1	For DP and USB3.2 Gen2x2, 5V@3A
HDMI1	HDMI connector
USB1/2	USB3.2 connector 1/2
LAN1/2	2 x RJ-45 Ethernet
LOUT1	Line-out audio jack
MIC1	Mic-in audio jack

2.4 EMX-MTLP Jumpers & Connectors settings

2.4.1 Clear CMOS (JCMOS1)

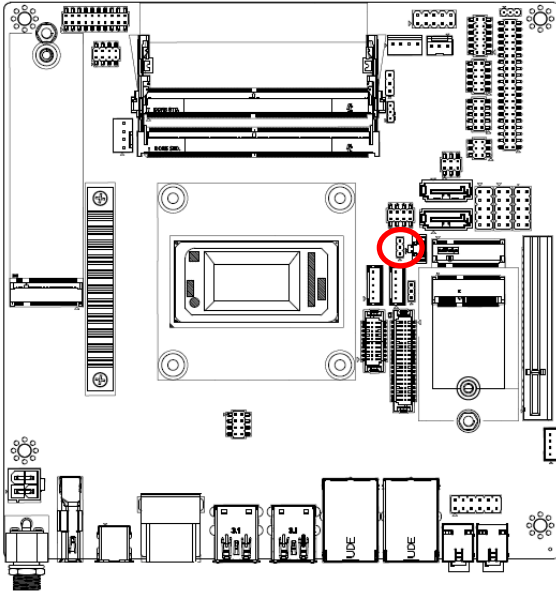

Normal*

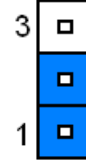

Clear CMOS

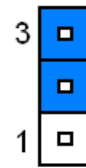

* Default

2.4.2 AT/ATX Power Mode Select (JAT1)

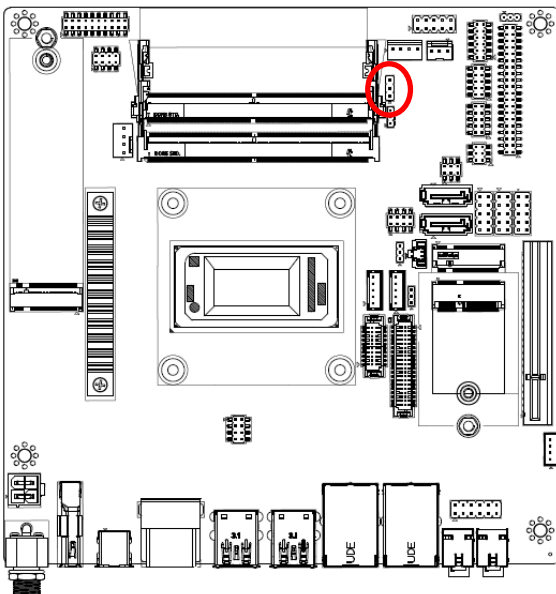

ATX*

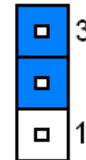

AT

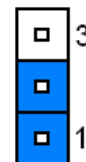

* Default

2.4.3 M.2 KeyB power selector (JM2BP1)

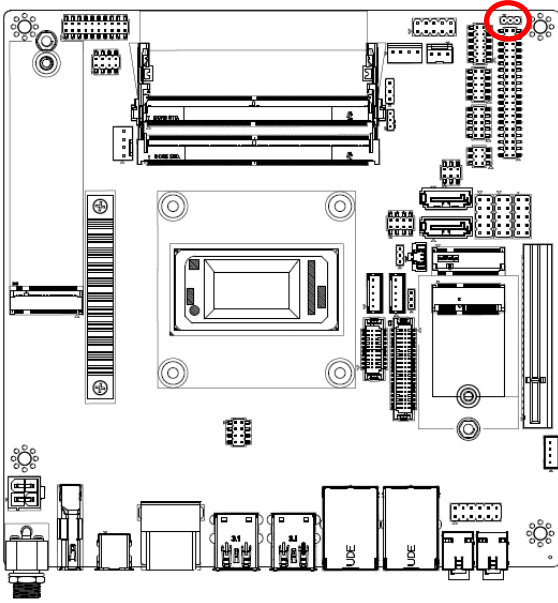

3.8V*

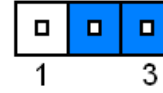

3.38V

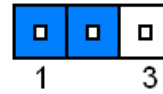

* Default

2.4.4 COM1 pin9 signal selector (JCOM1_PW1)

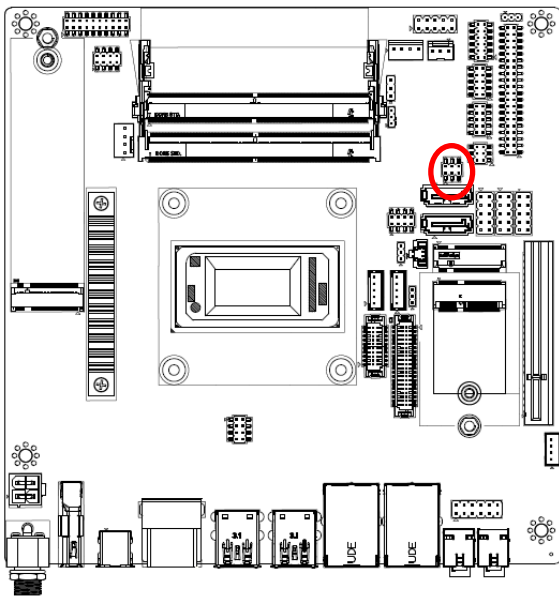

RI*

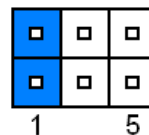

+5V

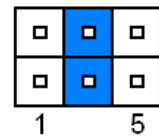

+12V

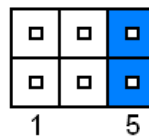

* Default

APC-2146

2.4.5 LVDS Backlight Power Select (JBL51)

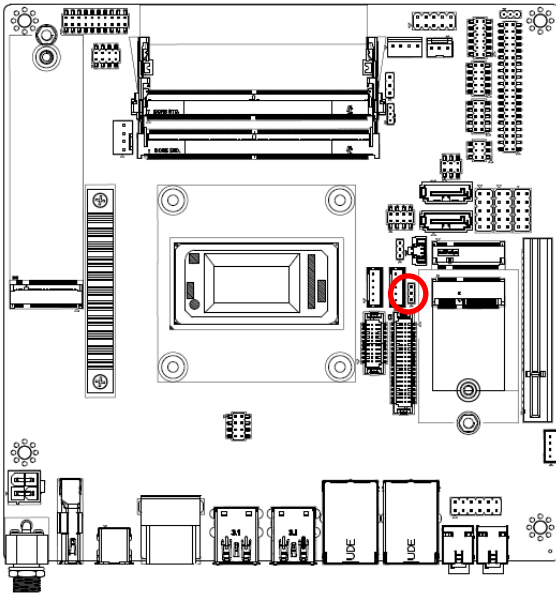

PWM*

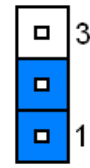

DC

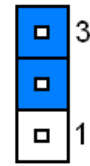

* Default

2.4.6 LVDS Backlight connector (JBL1)

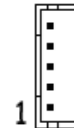
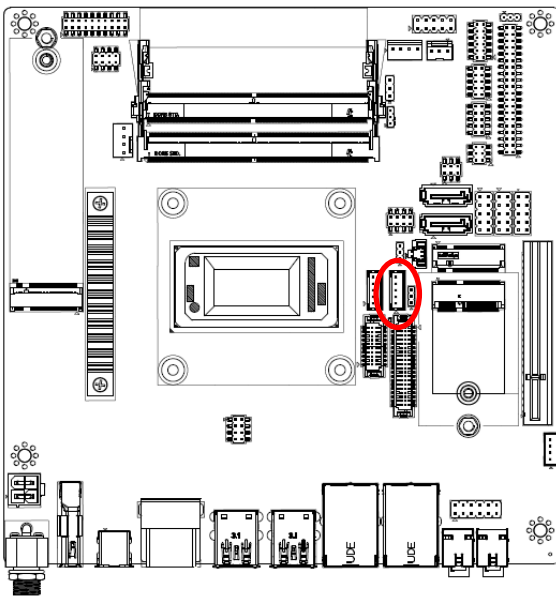

Signal	PIN
+5V	5
LVDS_BKLADJ	4
LVDS_BKLTEN	3
GND	2
+12V	1

2.4.7 SATA Power connector (JSPWR1)

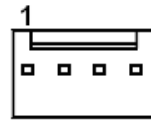
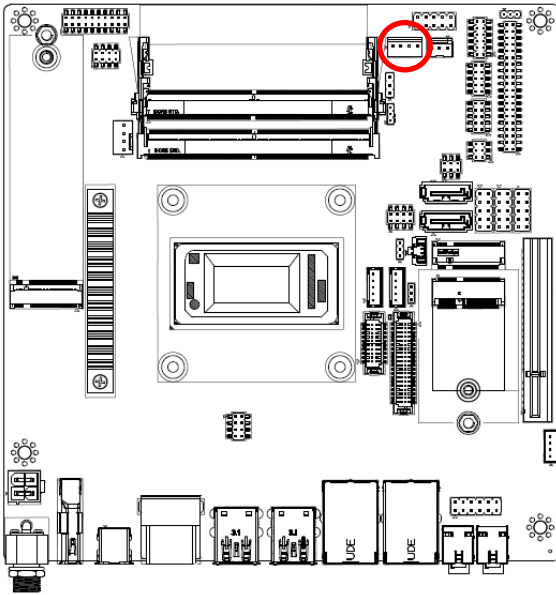

Signal	PIN
+5V	1
GND	2
GND	3
+12V	4

2.4.8 Amplifier Wafer (SPK1)

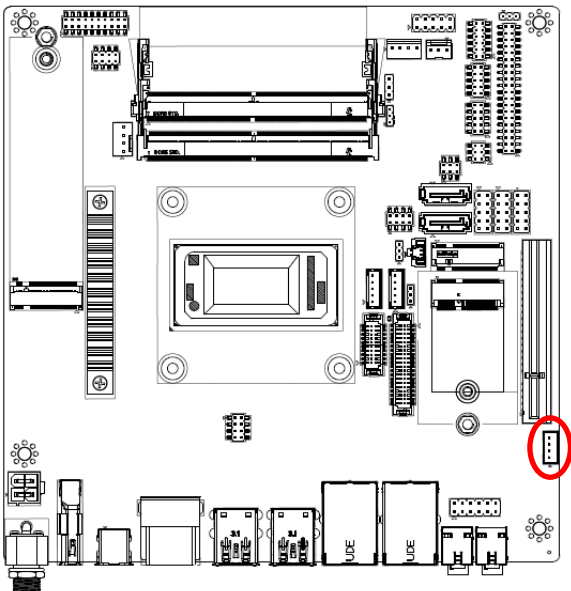

Signal	PIN
RSPK-	4
RSPK+	3
LSPK-	2
LSPK+	1

APC-2146

2.4.9 ESPI Debug Header (JESPI1)

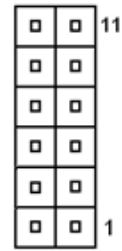
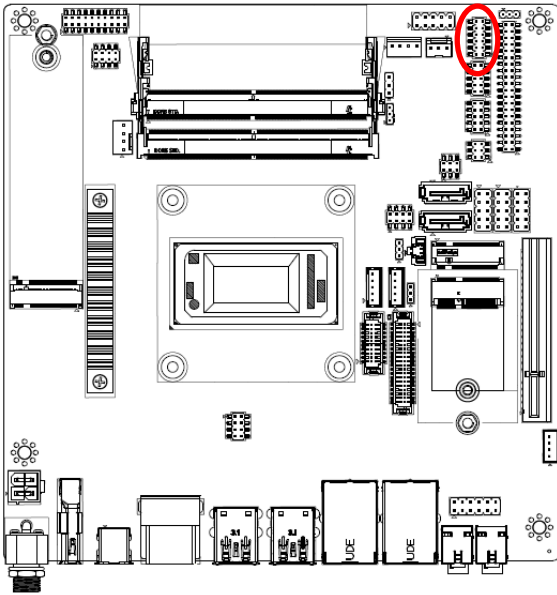

Signal	PIN	PIN	Signal
ESPI_ALERT1#	12	11	ESPI_RST#
GND	10	9	ESPI_CS1#
ESPI_CLK_80P	8	7	ESPI_IO3_80P
ESPI_CS#	6	5	ESPI_IO2_80P
PLT_RST#_BUF	4	3	ESPI_IO1_80P
+3.3V	2	1	ESPI_IO0_80P

2.4.10 Serial port 1 connector (JCOM1)

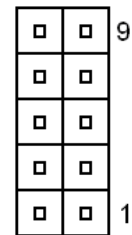
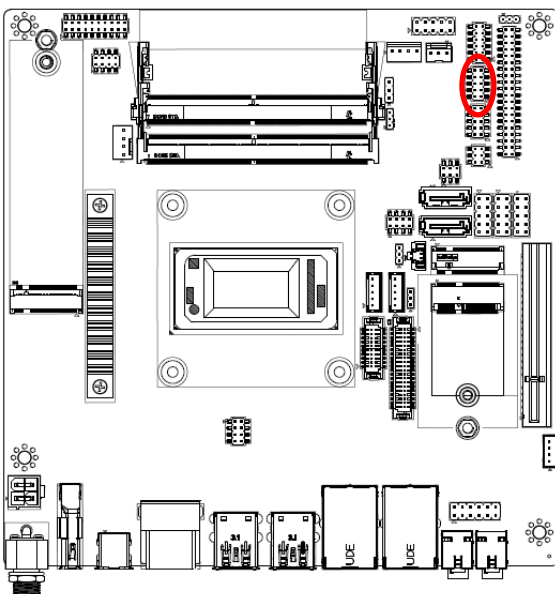

Signal	PIN	PIN	Signal
NC	10	9	RI#
CTS#	8	7	RTS#
DSR#	6	5	GND
DTR#	4	3	TXD
RXD	2	1	DCD#

Note: Pin9 can be selected by jumper (JCOM1_PW1) to RI / +5V / +12V

2.4.11 Serial port 2 connector (JCOM2)

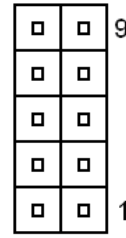
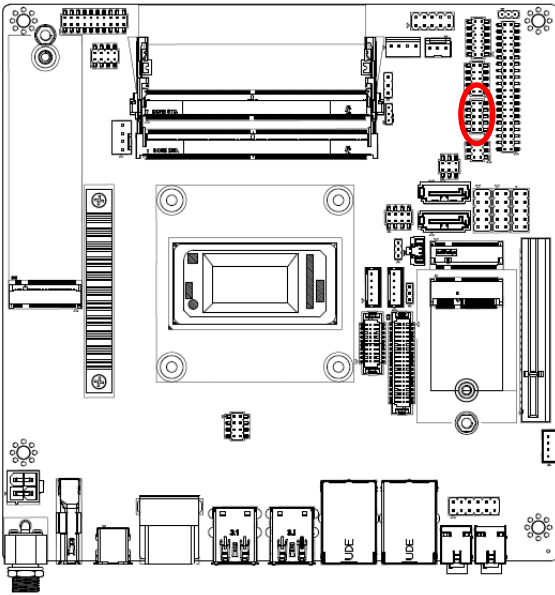

Signal	PIN	PIN	Signal
NC	10	9	RI#
CTS#	8	7	RTS#
DSR#	6	5	GND
DTR#	4	3	TXD
RXD	2	1	DCD#

2.4.12 RTC Battery connector (BT1)

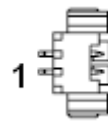
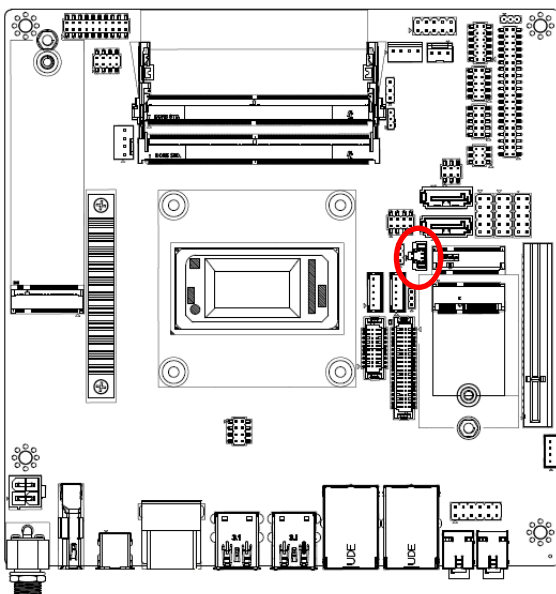

Signal	PIN
+VDD_RTC	1
GND	2

APC-2146

2.4.13 Serial Port 1 RS485/422 Mode connector (J485-1)

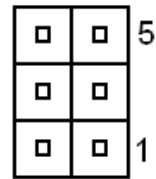
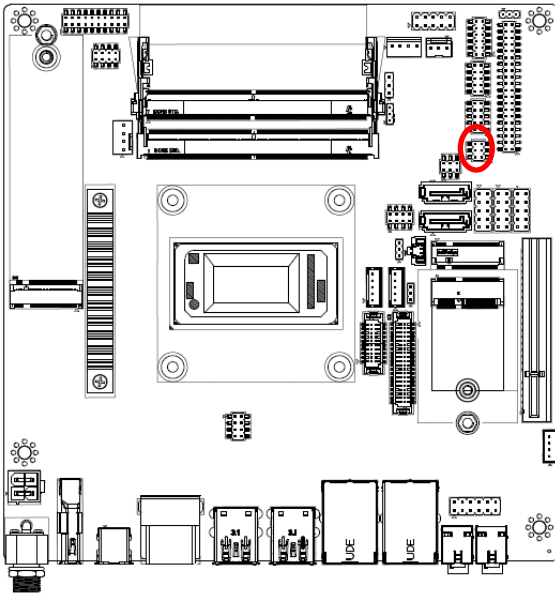

Signal	PIN	PIN	Signal
GND	6	5	+5V
422RX-	4	3	422RX+
485TX+	2	1	485TX-

2.4.14 USB2.0 connector (JUSB2)

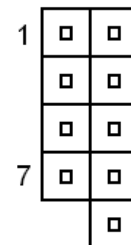
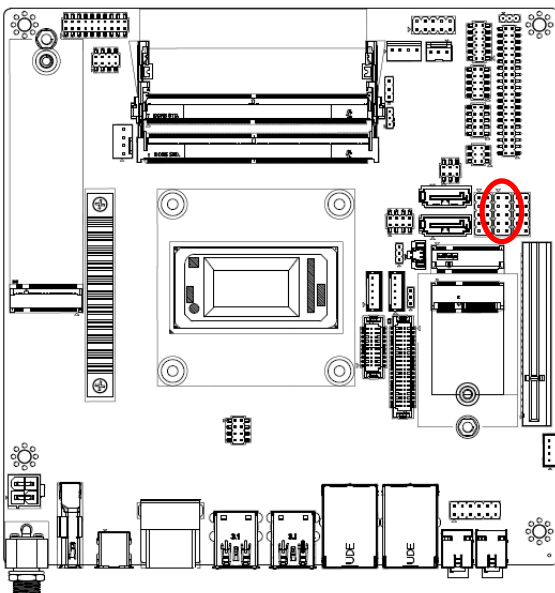

Signal	PIN	PIN	Signal
+5V	1	2	+5V
DATA-	3	4	DATA-
DATA+	5	6	DATA+
GND	7	8	GND
		10	NC

2.4.15 USB2.0 connector (JUSB3)

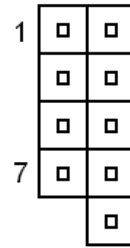
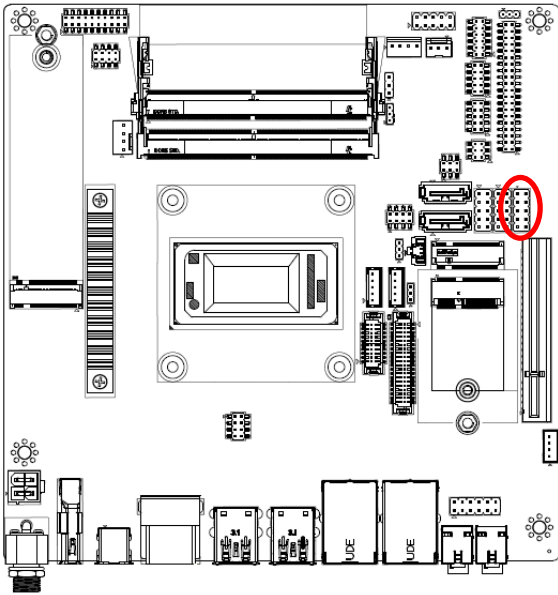

Signal	PIN	PIN	Signal
+5V	1	2	+5V
DATA-	3	4	DATA-
DATA+	5	6	DATA+
GND	7	8	GND
		10	NC

2.4.16 JPD connector (JPD1)

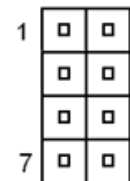
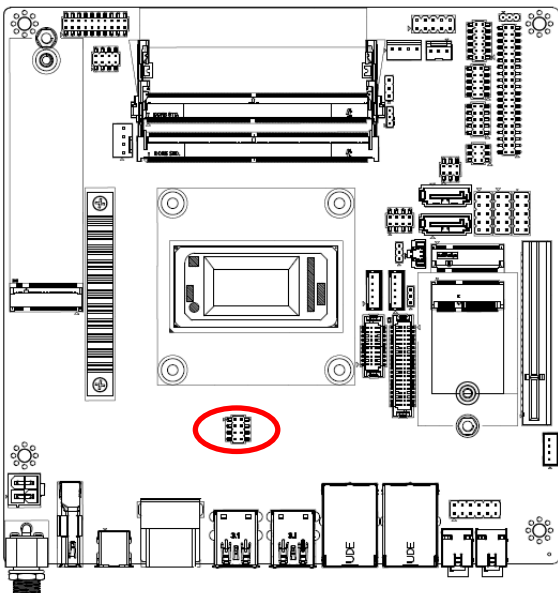

Signal	PIN	PIN	Signal
X_LDO_3V3	1	2	X_SML1_CLK_R
X_EEPROM_I2C_SCL	3	4	X_SML1_DAT_R
X_EEPROM_I2C_SDA	5	6	X_PMCALERT#_R
GND	7	8	GND

APC-2146

2.4.17 Front Panel connector (JFP1)

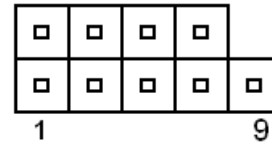
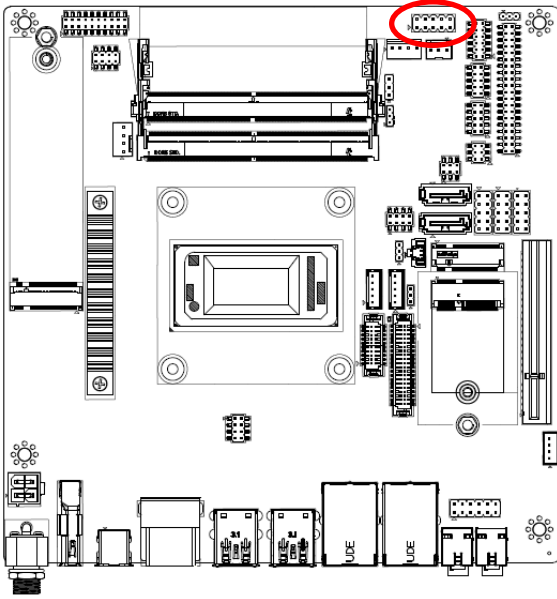

Function	Signal	PIN	PIN	Signal	Function
HDD LED	HDD_LED+	1	2	PWR_LED+	Power
	HDD_LED-	3	4	PWR_LED-	LED
Reset button	SYS_RST#	5	6	PWRBTN#	Power button
	GND	7	8	GND	
	NC	9			

2.4.18 LVDS connector (JLVDS1)

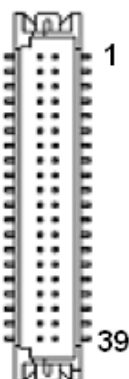
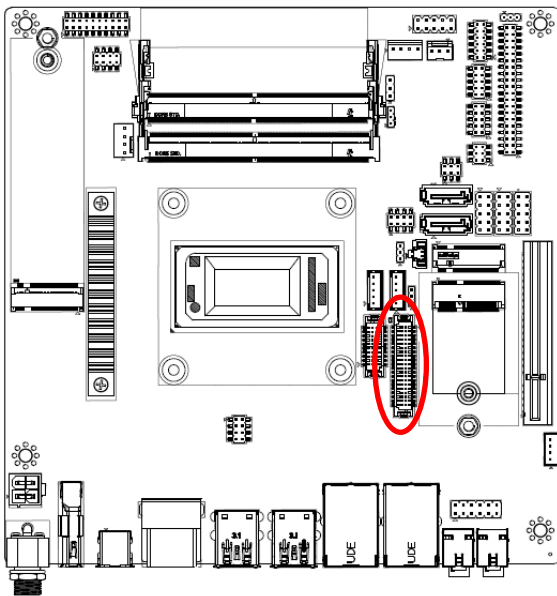

Signal	PIN	PIN	Signal
+5V	2	1	+3.3V
+5V	4	3	+3.3V
+5V	6	5	+3.3V
GND	8	7	GND
DATAP0	10	9	DATAP1
DATAN0	12	11	DATAN1
GND	14	13	GND
DATAP2	16	15	DATAP3
DATAN2	18	17	DATAN3
GND	20	19	GND
DATAP4	22	21	DATAP5
DATAN4	24	23	DATAN5
GND	26	25	GND
DATAP6	28	27	DATAP7
DATAN6	30	29	DATAN7
GND	32	31	GND
CLK1P	34	33	CLK2P
CLK1N	36	35	CLK2N
GND	38	37	GND
+12V	40	39	+12V

2.4.19 EC_Program (JEC_1)

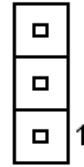
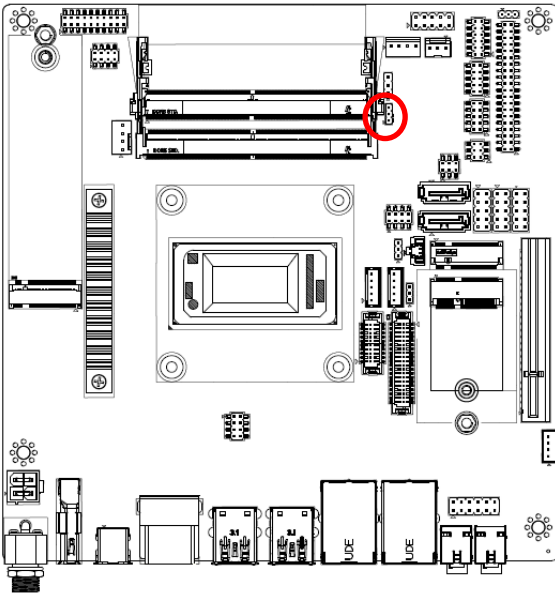

PIN	Signal
3	GND
2	EC_SMCLK_DEBUG
1	EC_SMDAT_DEBUG

2.4.20 BIOS SPI connector (JBIOS1)

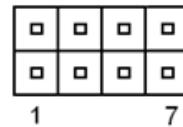
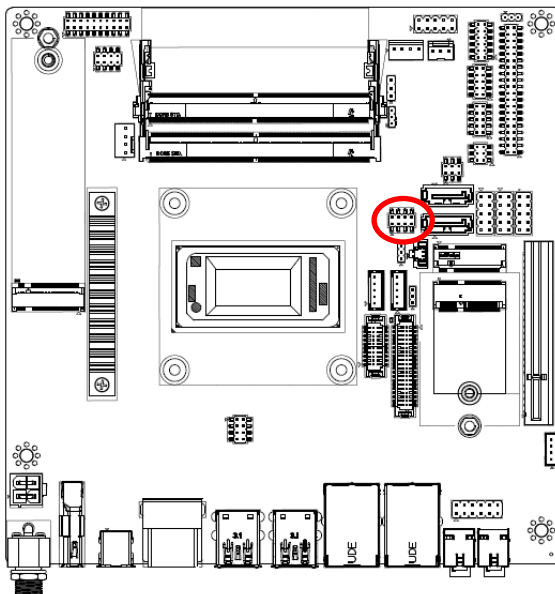

Signal	PIN	PIN	Signal
+1.8V	1	2	GND
SPI_ROM_CS#	3	4	SPI_ROM_CLK
SPI_ROM_MISO	5	6	SPI_ROM_MOSI
SPI_HOLD#	7	8	SPI_WP#

3. Installation



Removing the Top Cover Warning

To prevent electric shock or system damage, before removing the chassis cover, must turn off power and disconnect the unit from power source.

Electrostatic discharge (ESD) can cause serious damage to electronic components. Dry climates are especially susceptible to ESD. It is therefore critical that whenever the product is accessed internally, or any other electrical component is handled, the following anti-static precautions are strictly adhered to:

- **Wear an anti-static wristband:** Wearing a simple anti-static wristband can help to prevent ESD from damaging the board.
- **Self-grounding:** Before handling the board, touch any grounded conducting material. During the time the board is handled, frequently touch any conducting materials that are connected to the ground.
- **Use an anti-static pad:** When configuring the product, place it on an anti-static pad. This reduces the possibility of ESD damaging the product.
- **Only handle the edges of the PCB:** When handling the PCB, hold the PCB by the edges.

Installation Precautions

When installing the flat bezel panel PC, please follow the precautions listed below:

- **Power turned off:** When installing the flat bezel panel PC, make sure the power is off. Failing to turn off the power may cause severe injury to the body and/or damage to the system.
- **Certified Engineers:** Never open the equipment. For safety reasons, the equipment should be opened only by qualified skilled person.
- **Anti-static Discharge:** If a user open the rear panel of the flat bezel panel PC, to configure the jumpers or plug in added peripheral devices, ground themselves first and wear an anti-static wristband.

3.1 Installing Storage

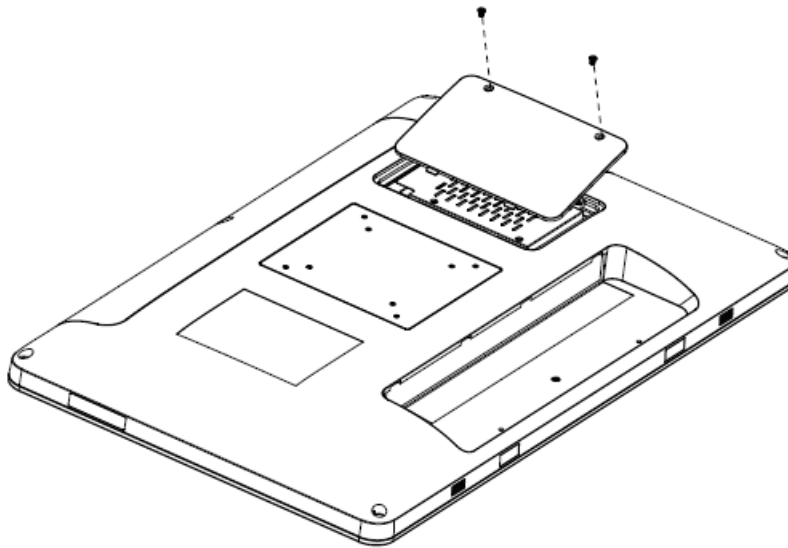

Step 1. Remove 2 screws to release the chassis cover and remove it.

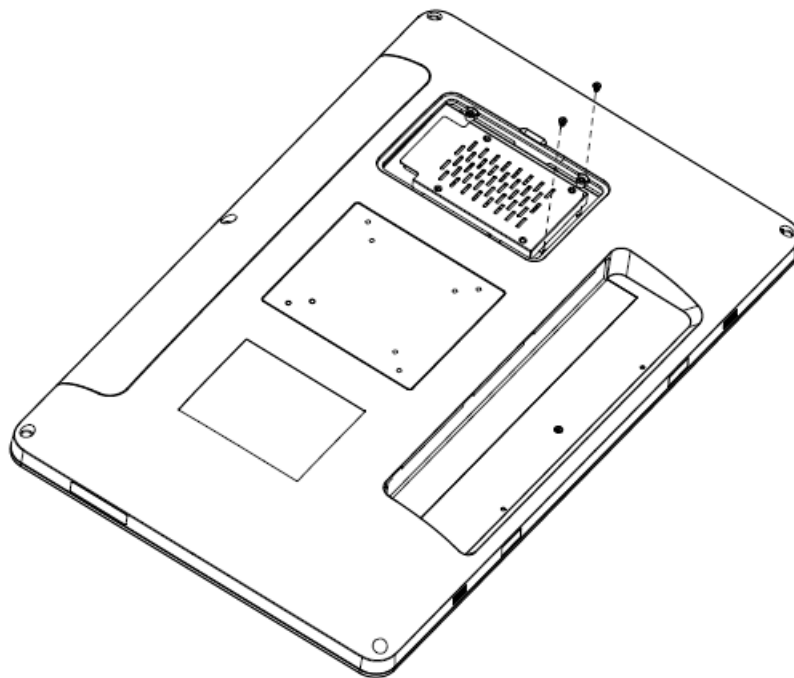

Step 2. Insert the HDD back and fasten 2 screws.

3.2 System Mounting

Warning! *More than one person should participate in mounting the panel PC to prevent accidental damage to the panel or personal injury.*



Safety Precautions

Observe the following common safety precautions before installing any electronic device:

- Use separate, non-intersecting paths to route power and networking wires. If power wiring and device wiring paths must be crossed make sure the wires are perpendicular at the intersection point.
- Keep the wires separated according to the interface. Wires that share similar electrical characteristics must be bundled together.
- Do not bundle input wiring with output wiring. Keep them separate.
- When necessary, it is strongly advised that you label wiring to all devices in the system.

4. Drivers Installation

All the drivers are available on Avalue Downloads Area (<https://www.avalu.com/en/support/download>). Type the model name and press Enter to find all the relevant software, utilities, and documentation.



Chipset **1**
Audio **2**
Graphics **1**
LAN **1**
Other Driver **3**
ME **1**

Chipset

No.	Release Date	Title, Description	Operating System	Download
01	2025-05-09	Intel MTL Chipset driver 10.1.19627.8423 Intel MTL Chipset driver 10.1.19627.8423	Windows 11 64bit	

Total **1** Files

Audio

No.	Release Date	Title, Description	Operating System	Download
01	2025-05-09	Realtek Audio Driver 9721.1 Realtek Audio Driver 9721.1	Windows 11 64bit	
02	2025-05-09	Intel(R)_SST_MTL_v20.40.10915.2 Intel(R)_SST_MTL_v20.40.10915.2	Windows 11 64bit	

Total **2** Files

(For reference only)



Note: Installation procedures and screen shots in this section are for your reference and may not be exactly the same as shown on your screen.

4.1 Install Chipset Driver

All drivers can be found on the Avalue Official Website:
www.avalue.com.



Note: The installation procedures and screen shots in this section are based on Windows 11 operation system.

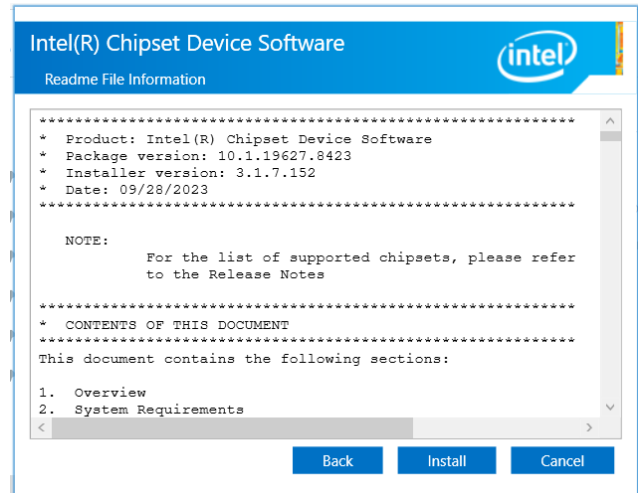

Step 3. Click Install.

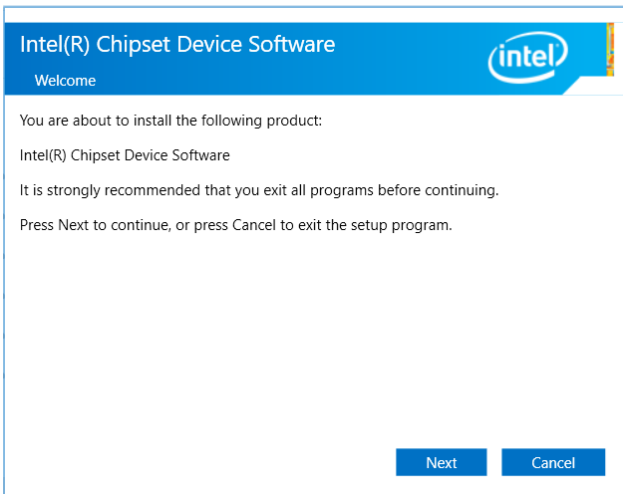

Step1. Click Next.

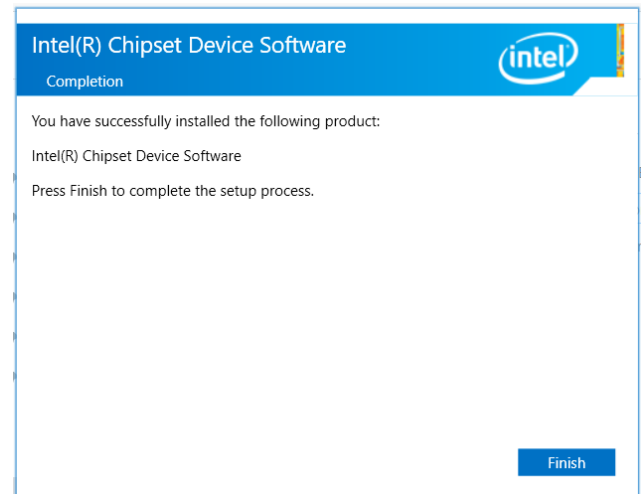

Step 4. Click Finish to complete setup.

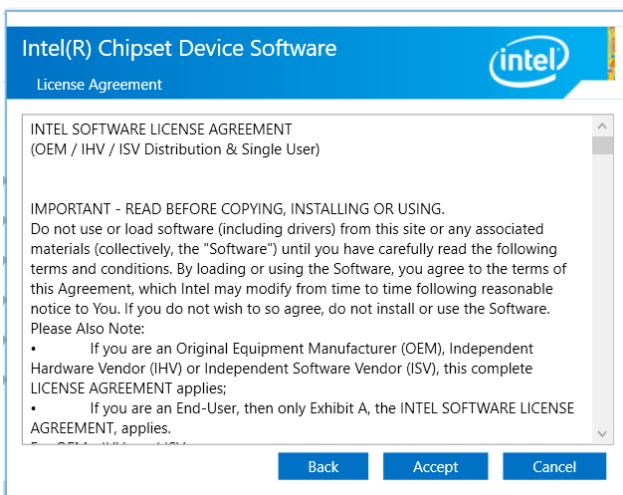

Step 2. Click Accept.

4.2 Install VGA Driver

All drivers can be found on the Avalue Official Website:
www.avalue.com.



Note: The installation procedures and screen shots in this section are based on Windows 11 operation system.

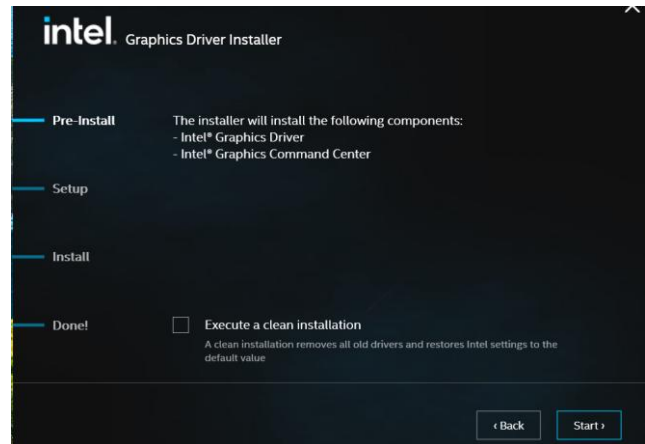

Step 3. Click **Accept**.

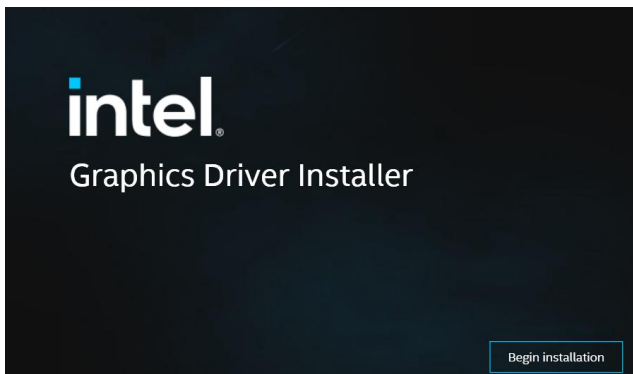

Step1. Click **Begin installation**.

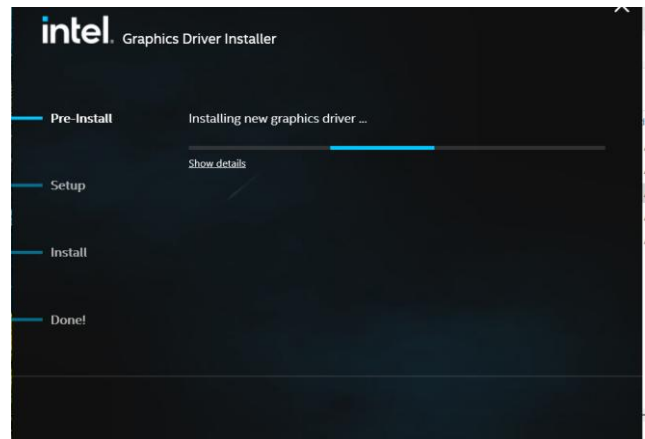

Step 4.

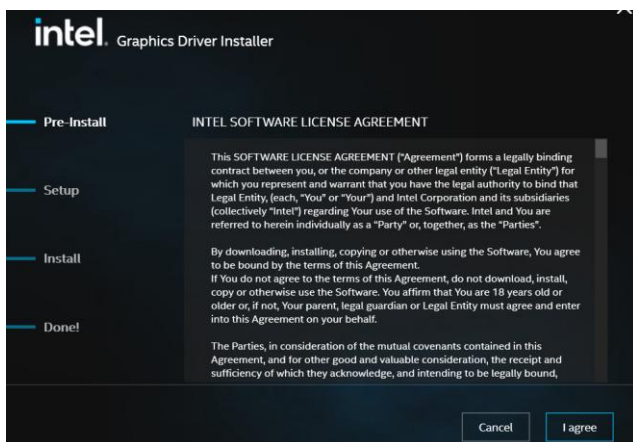

Step 2. Click **I agree**.

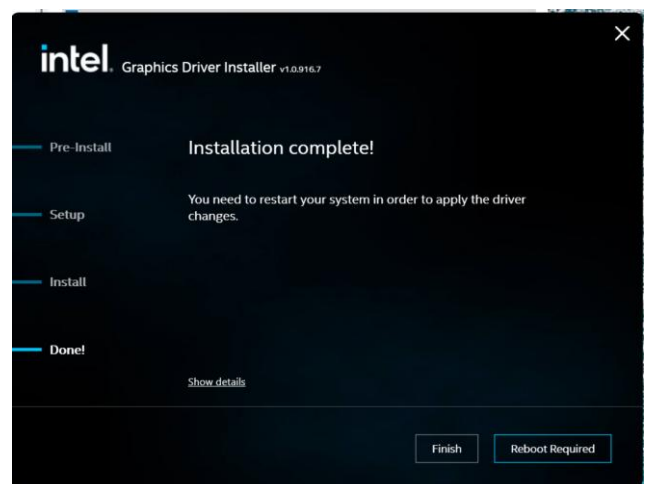

Step 5. Click **Finish** to complete setup.

4.3 Install ME Driver

All drivers can be found on the Avalue Official Website:
www.avalue.com.



Note: The installation procedures and screen shots in this section are based on Windows 11 operation system.

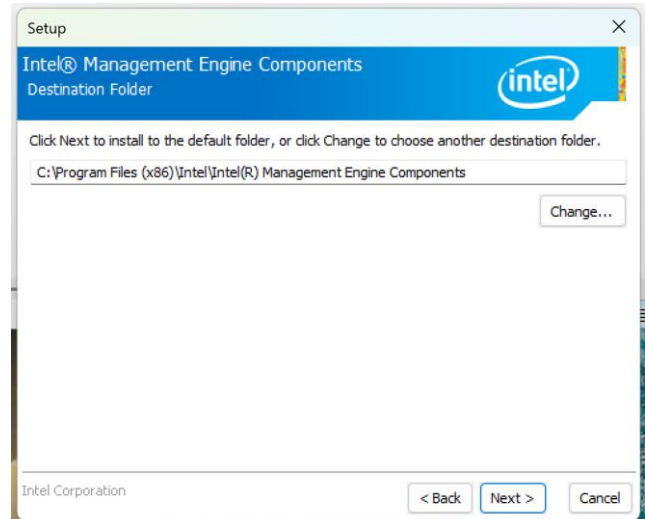

Step 3. Click Next.

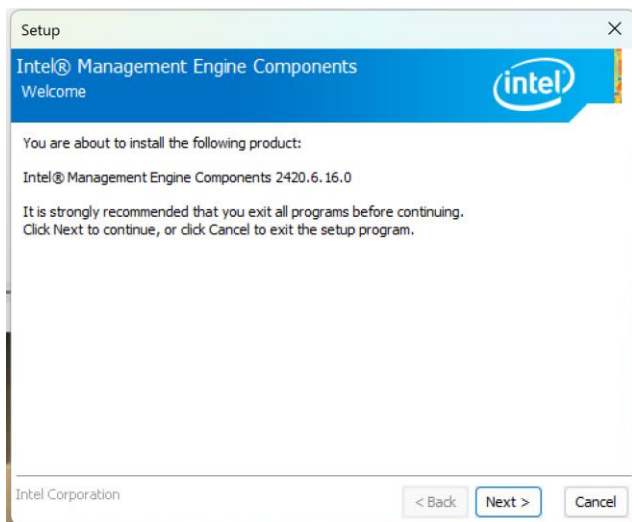

Step 1. Click Next to continue installation.

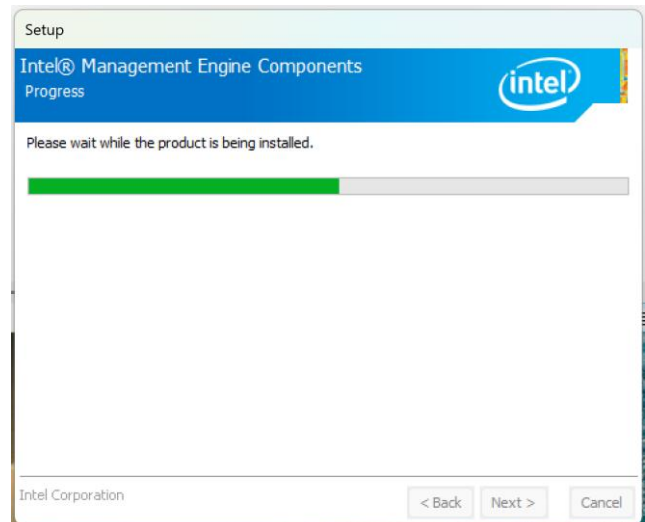

Step 4.

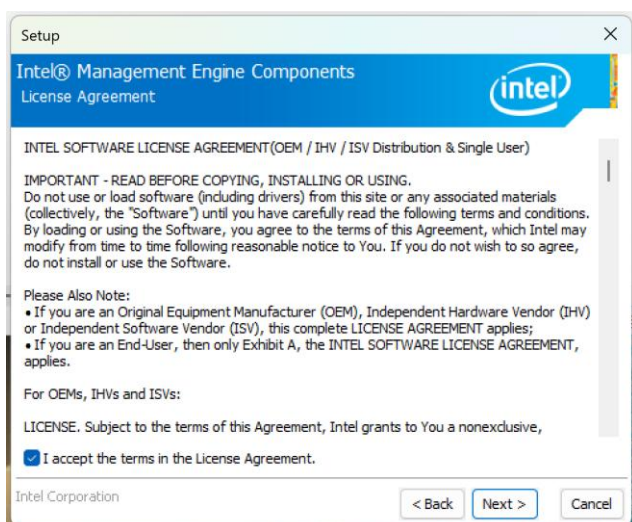

Step 2. Click Next.

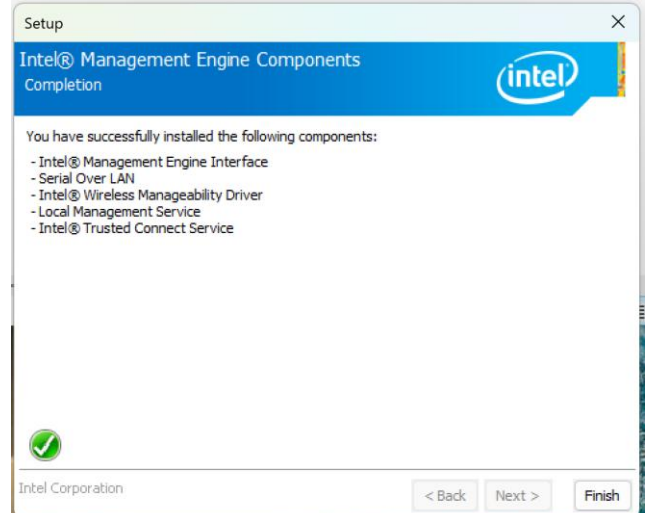

Step 5. Click Finish to complete setup.

4.4 Install Audio Driver

All drivers can be found on the Avalue Official Website:
www.avalue.com.



Note: The installation procedures and screen shots in this section are based on Windows 11 operation system.

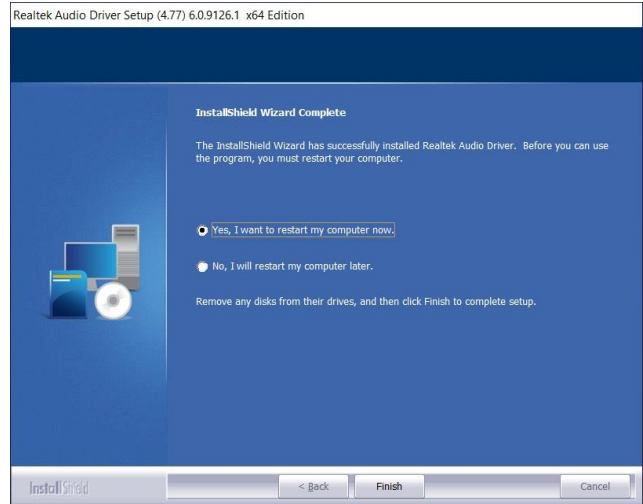

Step 3. Click **Finish** to complete setup.

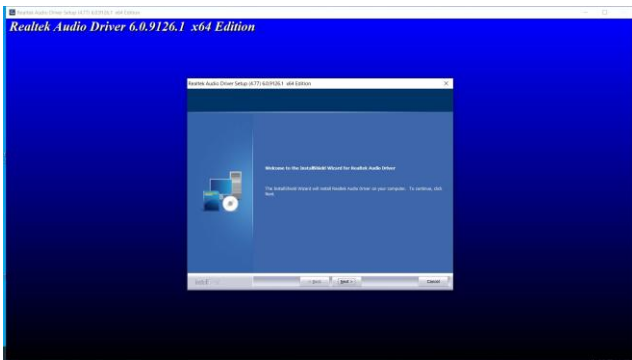

Step1. Click **Next**.

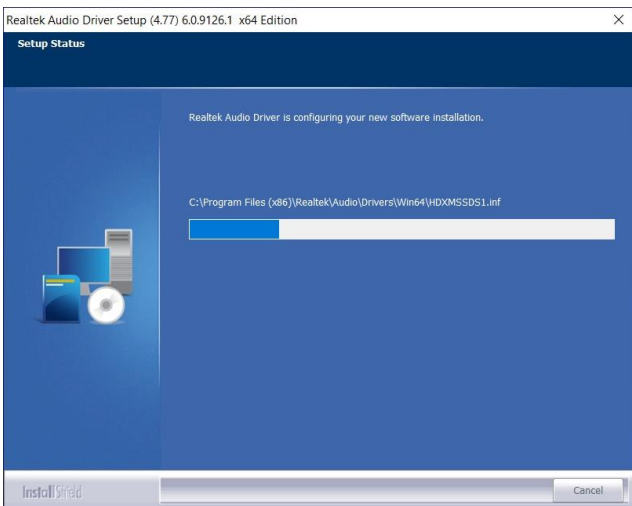

Step 2.

4.5 Install Serial IO Driver

All drivers can be found on the Avalue Official Website:
www.avalue.com.



Note: The installation procedures and screen shots in this section are based on Windows 11 operation system.

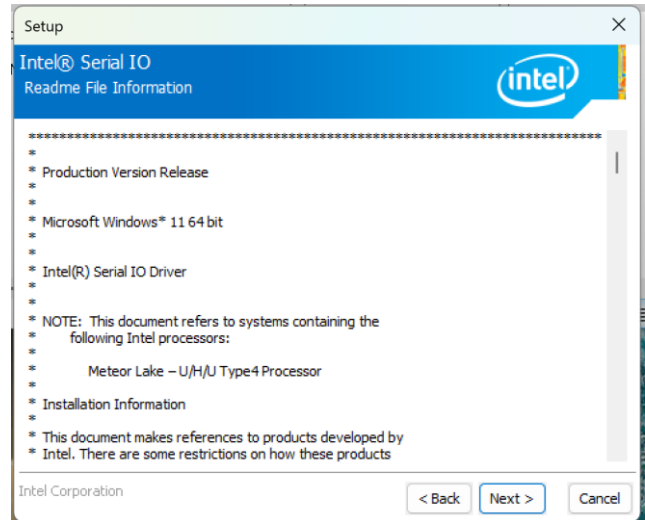

Step 3. Click Next.

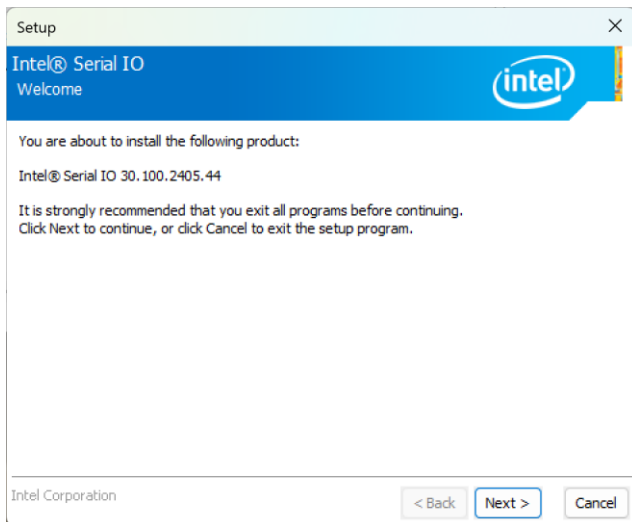

Step 1. Click Next to continue installation.

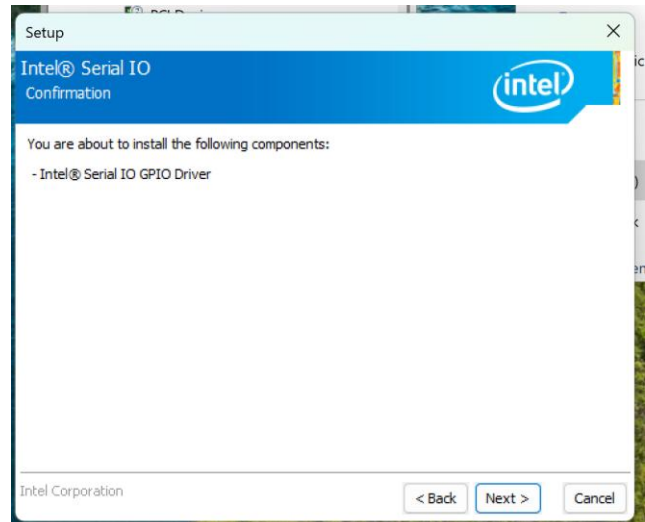

Step 4. Click Next.

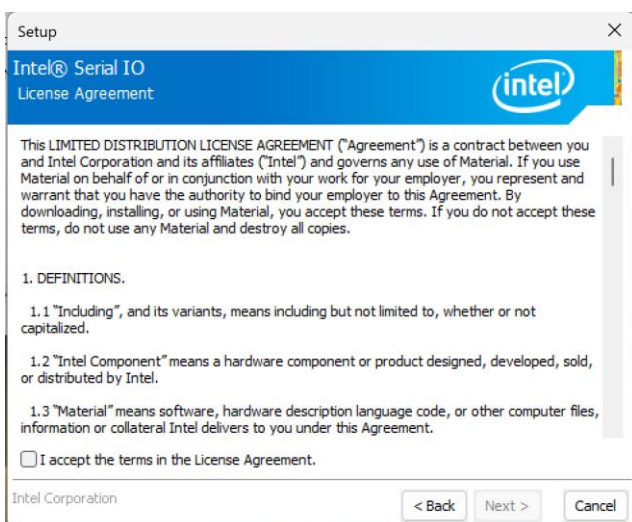

Step 2. Click Next.

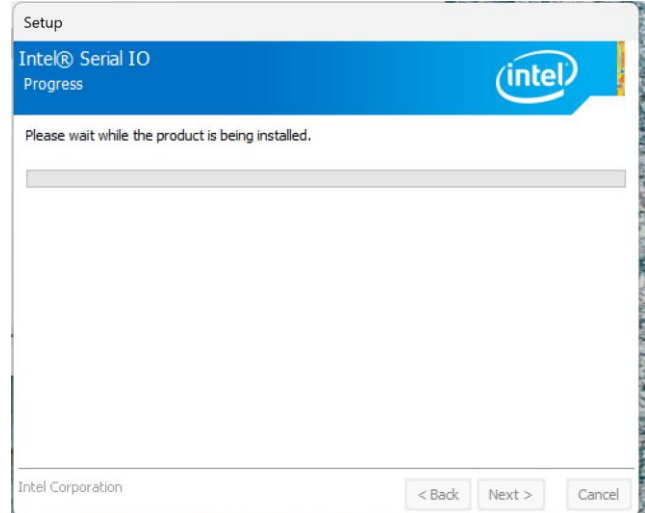

Step 5.

APC-2146

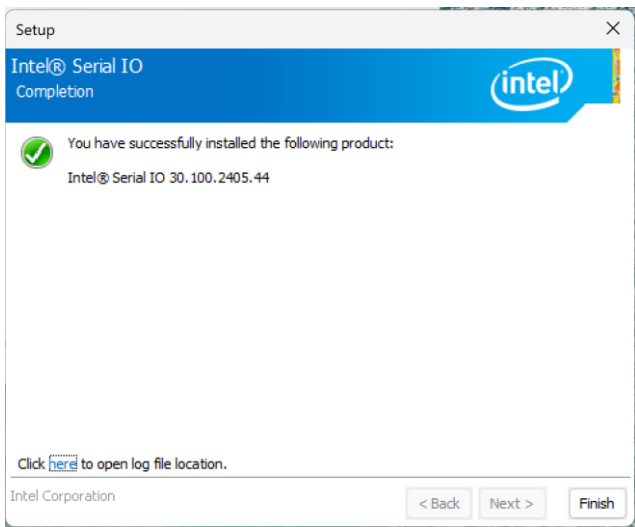

Step 6. Click **Finish** to complete setup.

4.6 Install Ethernet Driver

All drivers can be found on the Avalue

Official Website:

www.avalue.com.



Note: The installation procedures and screen shots in this section are based on Windows 11 operation system.

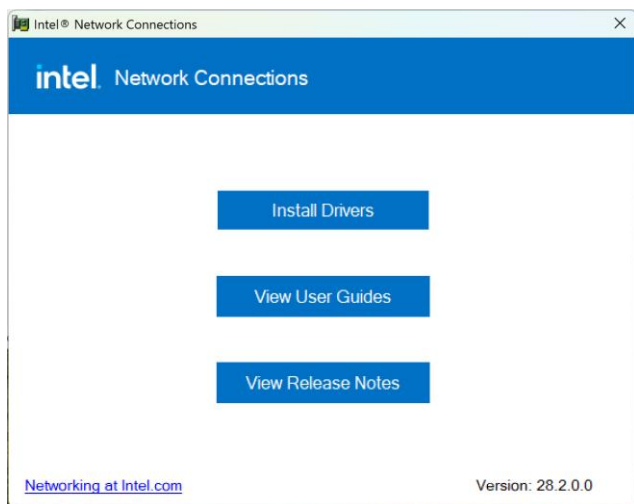

Step1. Click **Install Drivers** to continue installation.

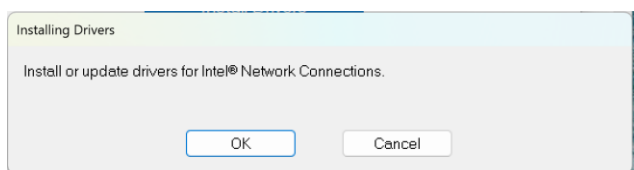

Step 2. Click **OK**.

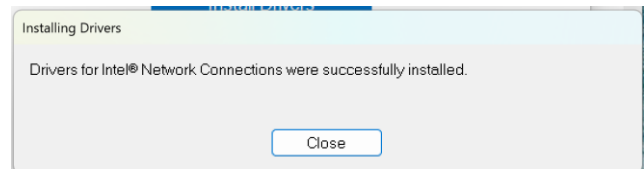

Step 3. Click **Close**.

4.7 Install Smart Sound Technology (ISST) Driver

All drivers can be found on the Avalue Official Website:
www.avalue.com.



Note: The installation procedures and screen shots in this section are based on Windows 11 operation system.

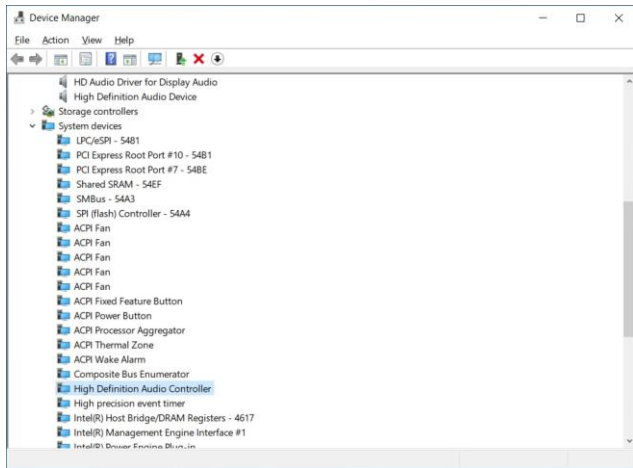

Step 1. Click High Definition Audio Controller.

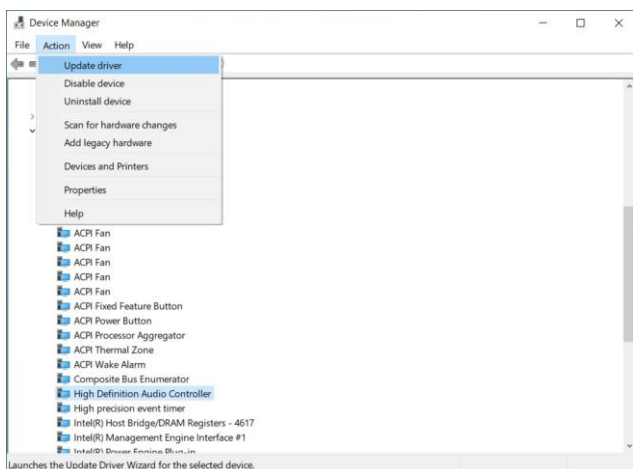

Step 2. Click Action Update driver.

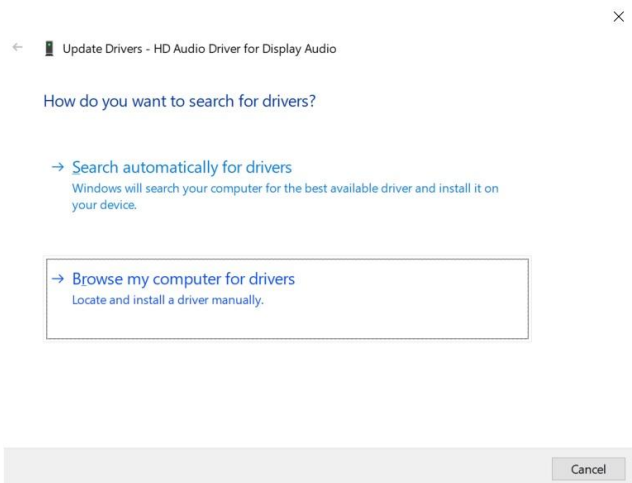

Step 3. Click Browse my computer for drivers.

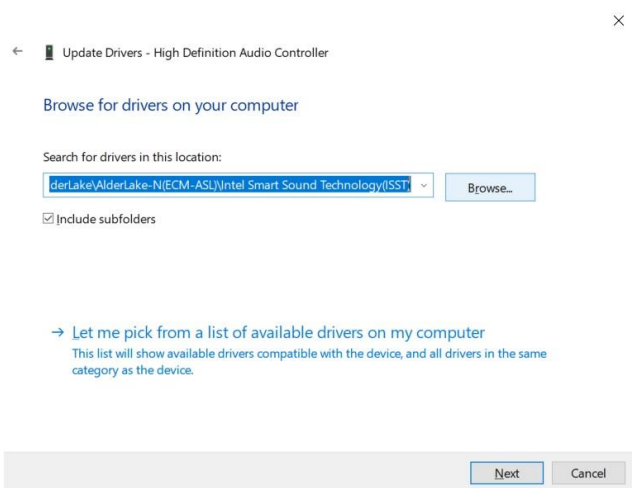

Step 4. Click Next.

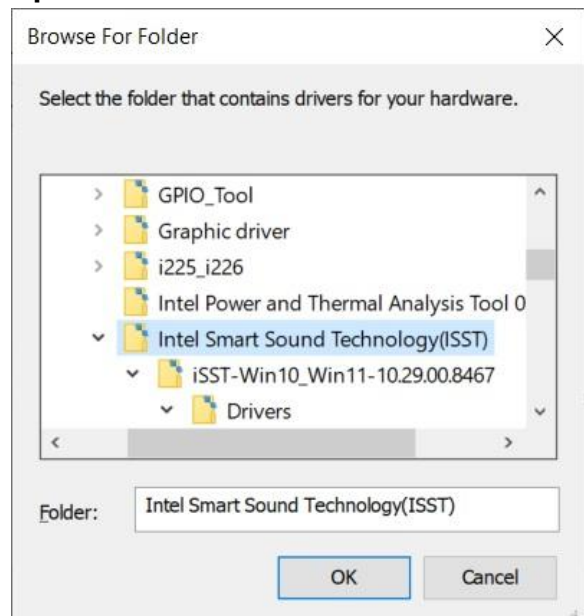

Step 5. Click OK.



Step 6.

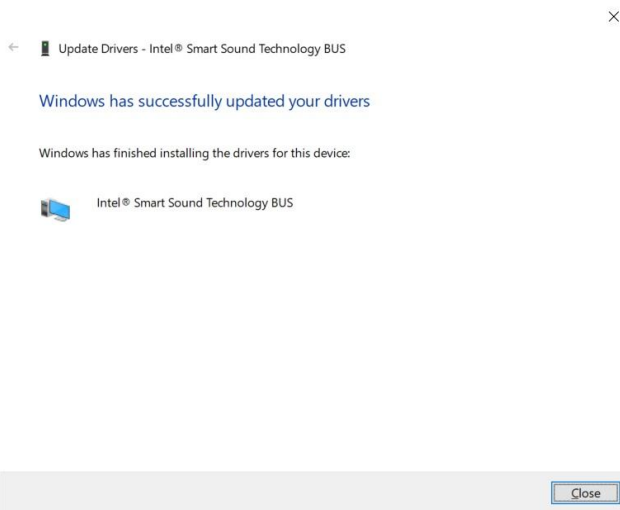

Step 7. Click **Close** to complete setup.

4.8 Install Intel@NPU Driver

All drivers can be found on the Avalue Official Website:
www.avalue.com.



Note: The installation procedures and screen shots in this section are based on Windows 11 operation system.

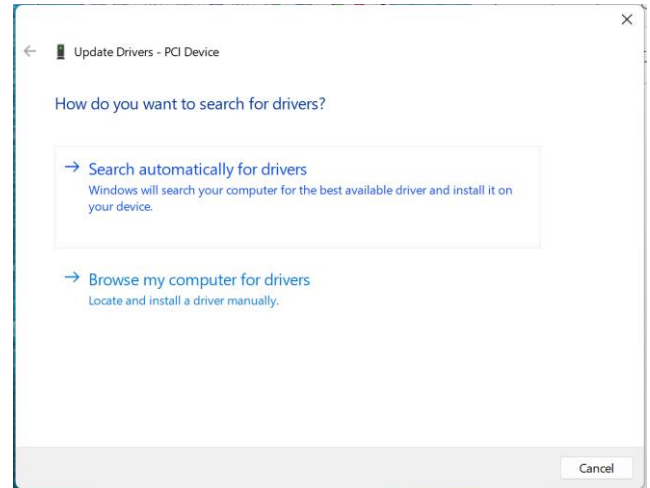

Step 2.

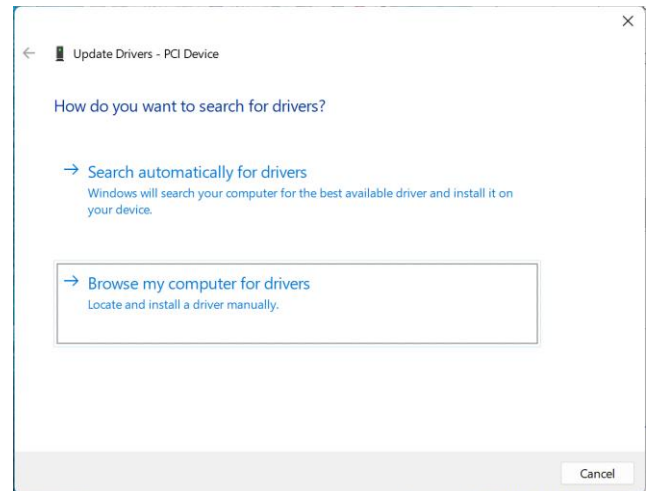

Step 3.

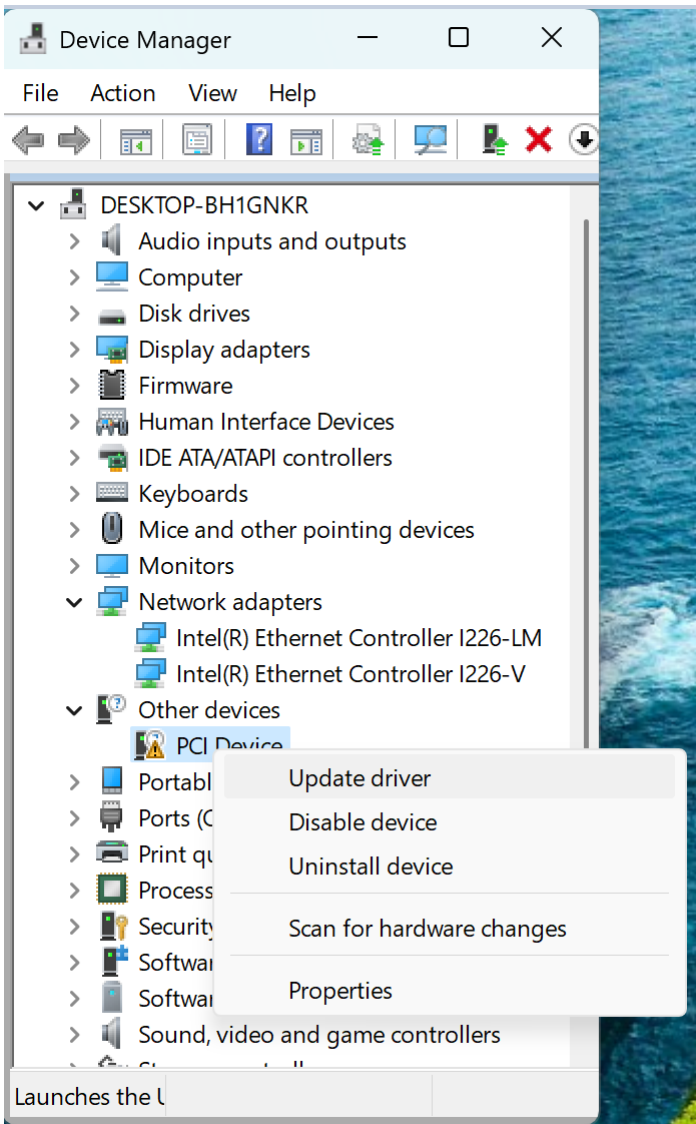
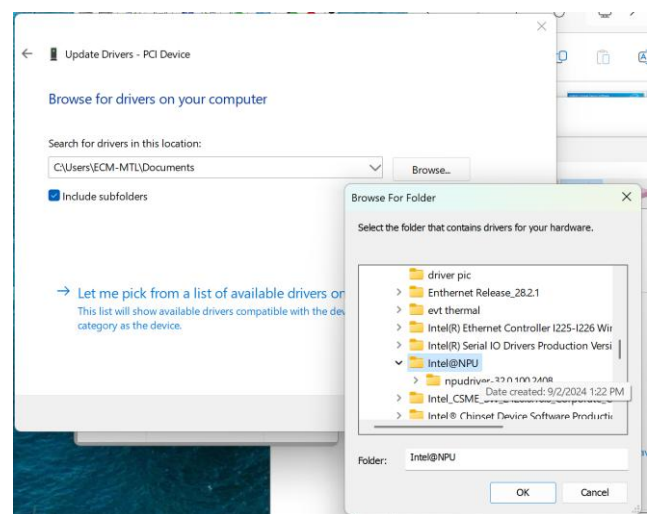

Step1. Click PCI Device.

Step 4. Click OK.

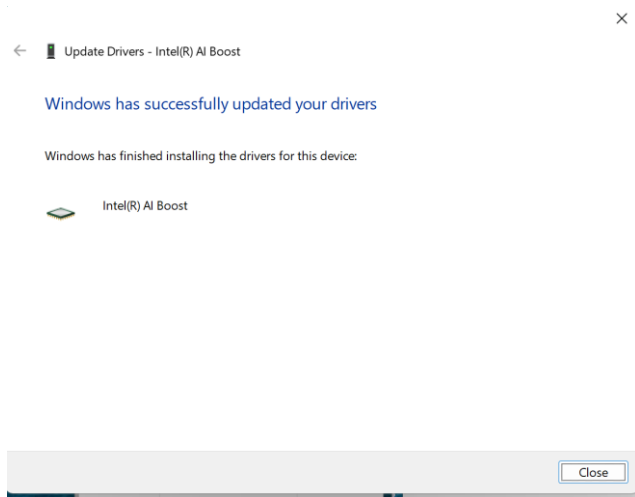

Step 5. Click **Close** to complete setup.

5. BIOS Setup

5.1 Introduction

The BIOS setup program allows users to modify the basic system configuration. In this following chapter will describe how to access the BIOS setup program and the configuration options that may be changed.

5.2 Starting Setup

AMI BIOS™ is immediately activated when you first power on the computer. The BIOS reads the system information contained in the NVRAM and begins the process of checking out the system and configuring it. When it finishes, the BIOS will seek an operating system on one of the disks and then launch and turn control over to the operating system.

While the BIOS is in control, the Setup program can be activated in one of two ways:

By pressing <ESC> or immediately after switching the system on, or

By pressing the < ESC> or key when the following message appears briefly at the left-top of the screen during the POST (Power On Self Test).

Press <ESC> or to enter SETUP

If the message disappears before you respond and you still wish to enter Setup, restart the system to try again by turning it OFF then ON or pressing the "RESET" button on the system case. You may also restart by simultaneously pressing <Ctrl>, <Alt>, and <Delete> keys.

5.3 Using Setup

In general, you use the arrow keys to highlight items, press <Enter> to select, use the PageUp and PageDown keys to change entries, press <F1> for help and press <Esc> to quit. The following table provides more detail about how to navigate in the Setup program using the keyboard.

Button	Description
↑	Move to previous item
↓	Move to next item
←	Move to the item in the left hand
→	Move to the item in the right hand
Esc key	Main Menu -- Quit and not save changes into NVRAM Status Page Setup Menu and Option Page Setup Menu -- Exit current page and return to Main Menu
+ key	Increase the numeric value or make changes
- key	Decrease the numeric value or make changes
F1 key	General help, only for Status Page Setup Menu and Option Page Setup Menu
F2 key	Previous Values
F3 key	Optimized defaults
F4 key	Save & Exit Setup

- **Navigating Through The Menu Bar**

Use the left and right arrow keys to choose the menu you want to be in.



Note: Some of the navigation keys differ from one screen to another.

- **To Display a Sub Menu**

Use the arrow keys to move the cursor to the sub menu you want. Then press <Enter>. A “➤” pointer marks all sub menus.

5.4 Getting Help

Press F1 to pop up a small help window that describes the appropriate keys to use and the possible selections for the highlighted item. To exit the Help Window press <Esc> or the <Enter> key again.

5.5 In Case of Problems

If, after making and saving system changes with Setup, you discover that your computer no longer is able to boot, the AMI BIOS supports an override to the NVRAM settings which resets your system to its defaults.

The best advice is to only alter settings which you thoroughly understand. To this end, we strongly recommend that you avoid making any changes to the chipset defaults. These defaults have been carefully chosen by both BIOS Vendor and your systems manufacturer to provide the absolute maximum performance and reliability. Even a seemingly small change to the chipset setup has the potential for causing you to use the override.

5.6 BIOS setup

Once you enter the Aptio Setup Utility, the Main Menu will appear on the screen. The Main Menu allows you to select from several setup functions and exit choices. Use the arrow keys to select among the items and press <Enter> to accept and enter the sub-menu.

5.6.1 Main Menu

This section allows you to record some basic hardware configurations in your computer and set the system clock.

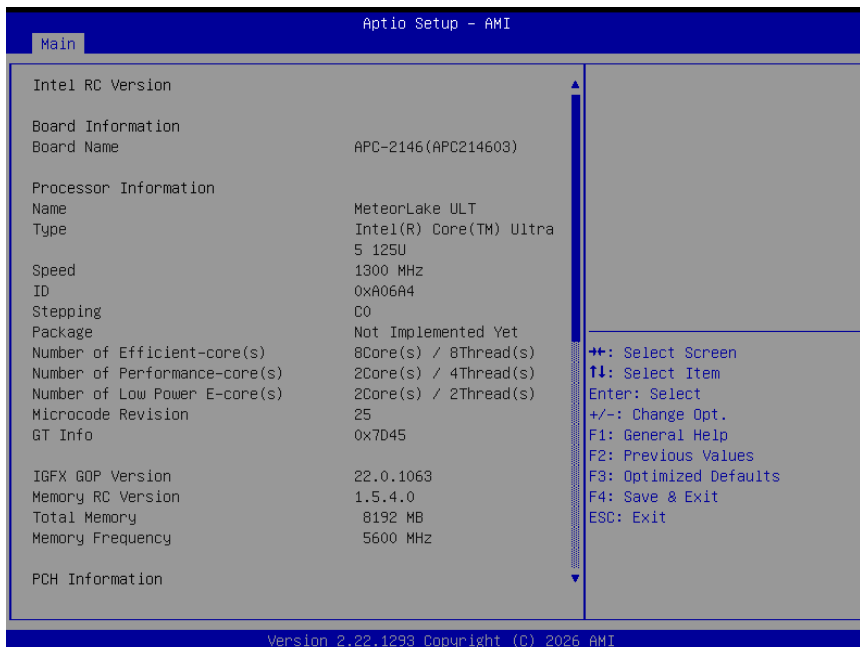
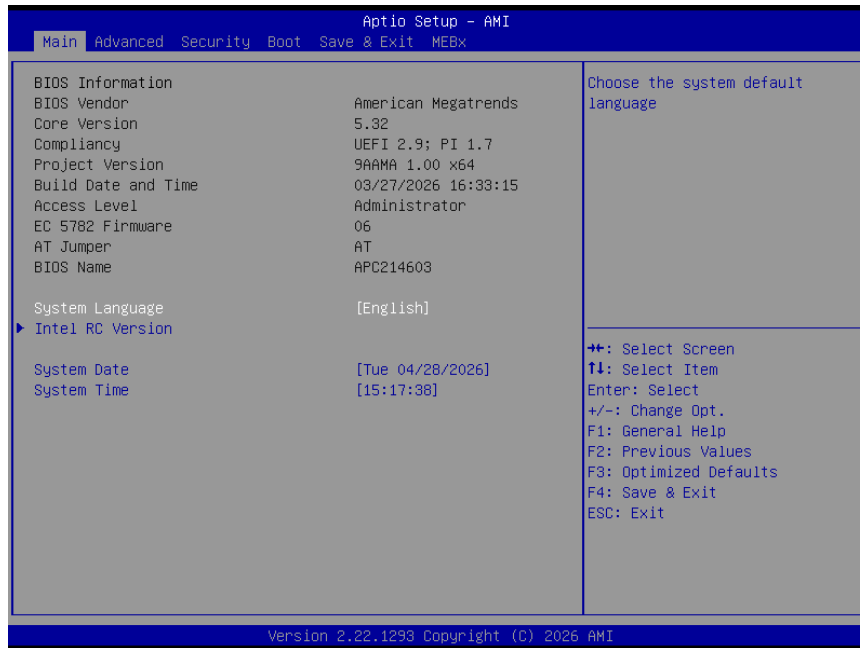

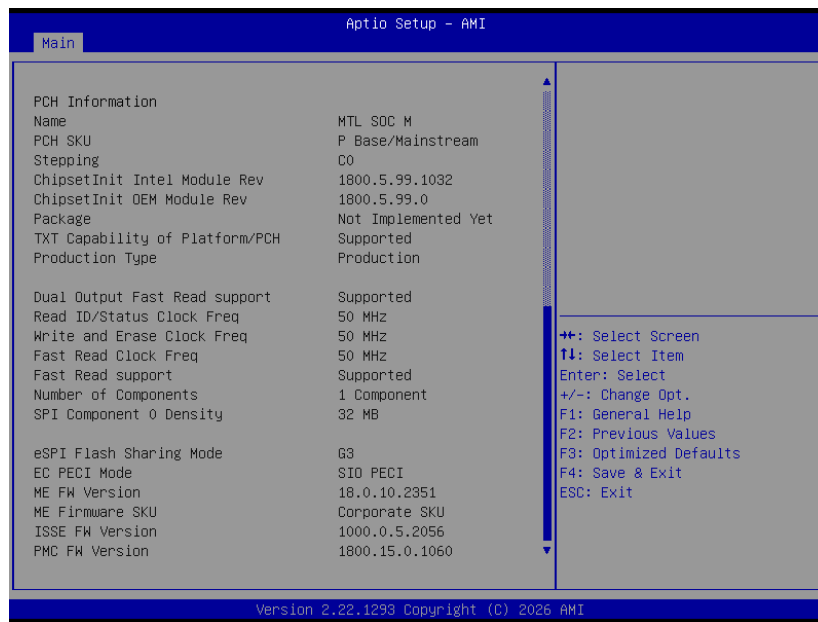

5.6.1.1 System Language

This option allows choosing the system default language.

5.6.1.2 System Date

Use the system date option to set the system date. Manually enter the Month, day and year.

5.6.1.3 System Time

Use the system time option to set the system time. Manually enter the hours, minutes and seconds.



Note: The BIOS setup screens shown in this chapter are for reference purposes only, and may not exactly match what you see on your screen.

Visit the Avalue website (www.avaluel.com) to download the latest product and BIOS information.

5.6.2 Advanced Menu

This section allows you to configure your CPU and other system devices for basic operation through the following sub-menus.

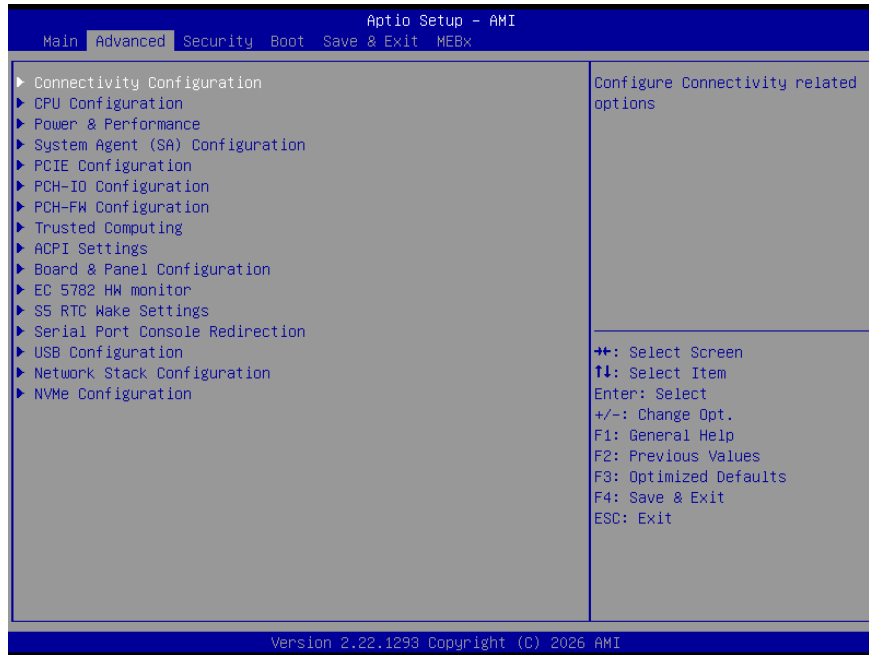

5.6.2.1 Connectivity Configuration



Item	Options	Description
CNVi Mode	Disable Integrated Auto Detection[Default],	This option configures Connectivity. [Auto Detection] means that if Discrete solution is discovered it will be enabled by default. Otherwise Integrated solution (CNVi) will be enabled; [Disable Integrated] disables Integrated Solution. NOTE: When CNVi is present, the GPIO pins that are used for radio interface cannot be assigned to the other native function.

5.6.2.2 CPU Configuration

Use the CPU configuration menu to view detailed CPU specification and configure the CPU.



Item	Options	Description
Intel (VMX) Virtualization Technology	Disabled Enabled[Default]	When enabled, a VMM can utilize the additional hardware capabilities provided by Vanderpool Technology.
Active Performance-cores	All[Default] /7/6/5/4/3/2/1	Number of P-cores to enable in each processor package. Note: Number of Cores and E-Cores are looked at together. When both are {0,0}, Pcode will enable all cores.
Active Efficient-cores	All[Default] /31/30/29/28/27/26/25/ 24/23/22/21/20/19/18/17 /16/15/14/13/12/11/10/9/ 8/7/6/5/4/3/2/1/0	Number of E-cores to enable in each processor package. Note: Number of Cores and E-Cores are looked at together. When both are {0,0}, Pcode will enable all cores.

5.6.2.2.1 Efficient-core Information

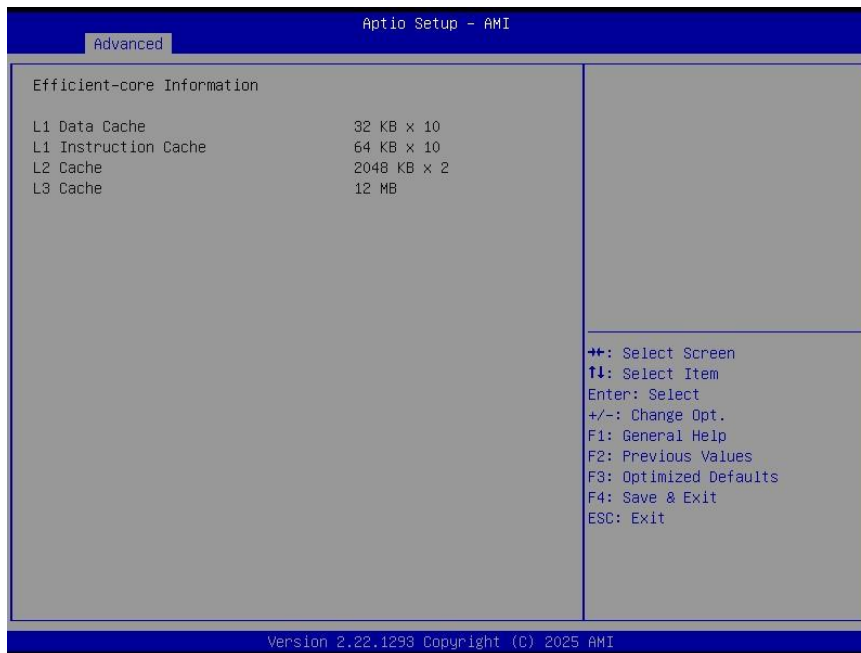

5.6.2.2.2 Performance-core Information

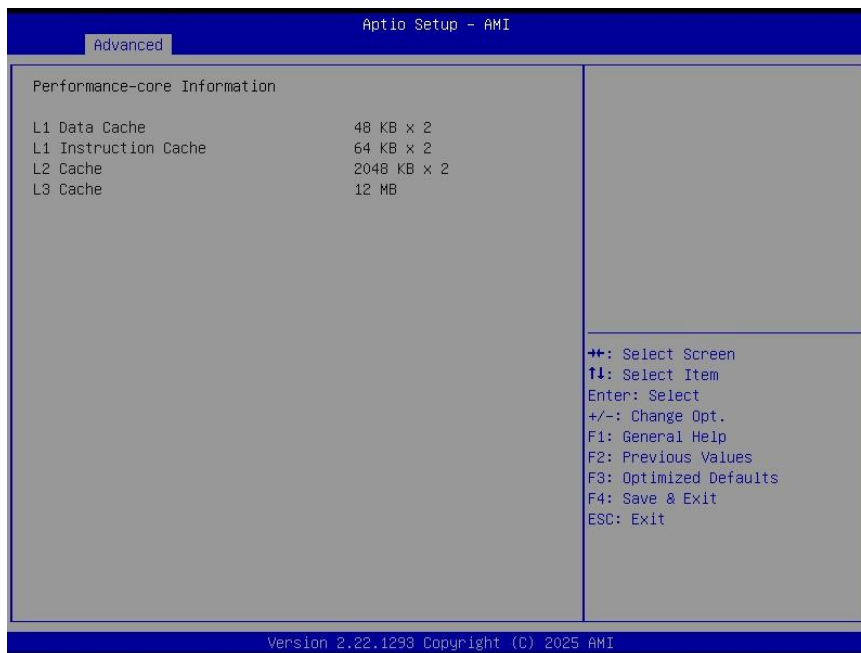

5.6.2.3 Power & Performance

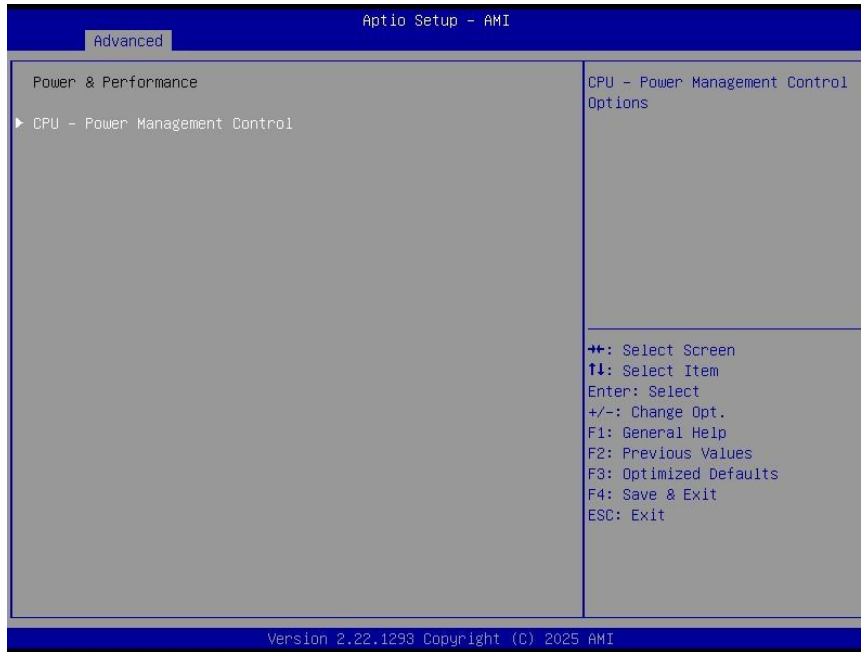

5.6.2.3.1 CPU - Power Management Control

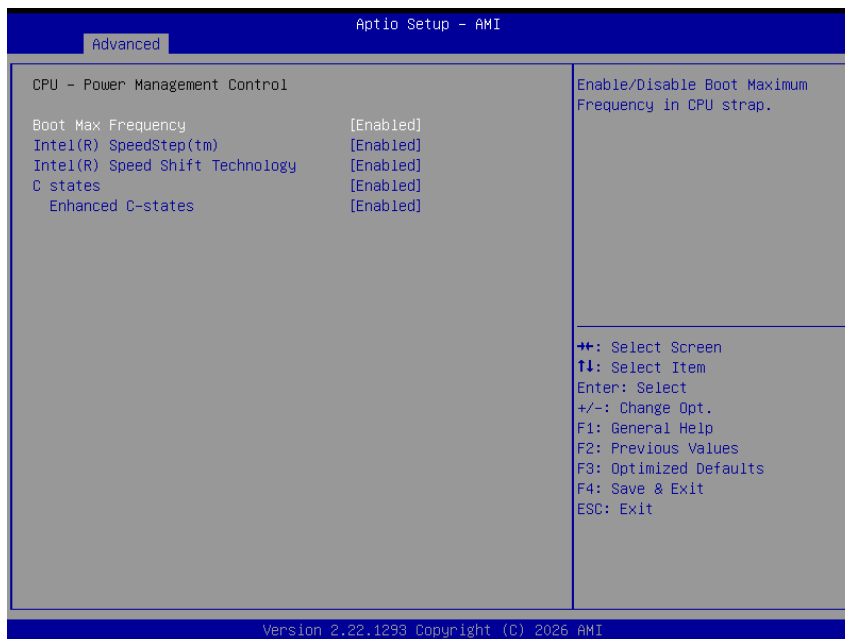

Item	Options	Description
Boot Max Frequency	Disabled Enabled[Default]	Enable/Disable Boot Maximum Frequency in CPU strap.
Intel(R) SpeedStep(tm)	Disabled Enabled[Default]	Allows more than two frequency ranges to be supported.

APC-2146

Intel(R) Speed Shift Technology	Disabled Enabled[Default]	Enable/Disable Intel(R) Speed Shift Technology support. Enabling will expose the CPPC v2 interface to allow for hardware controlled P-states.
C states	Disabled Enabled[Default]	Enable/Disable CPU Power Management. Allows CPU to go to C states when it's not 100% utilized.
Enhanced C-states	Disabled Enabled[Default]	Enable/Disable C1E. When enabled, CPU will switch to minimum speed when all cores enter C-State.

5.6.2.4 System Agent (SA) Configuration

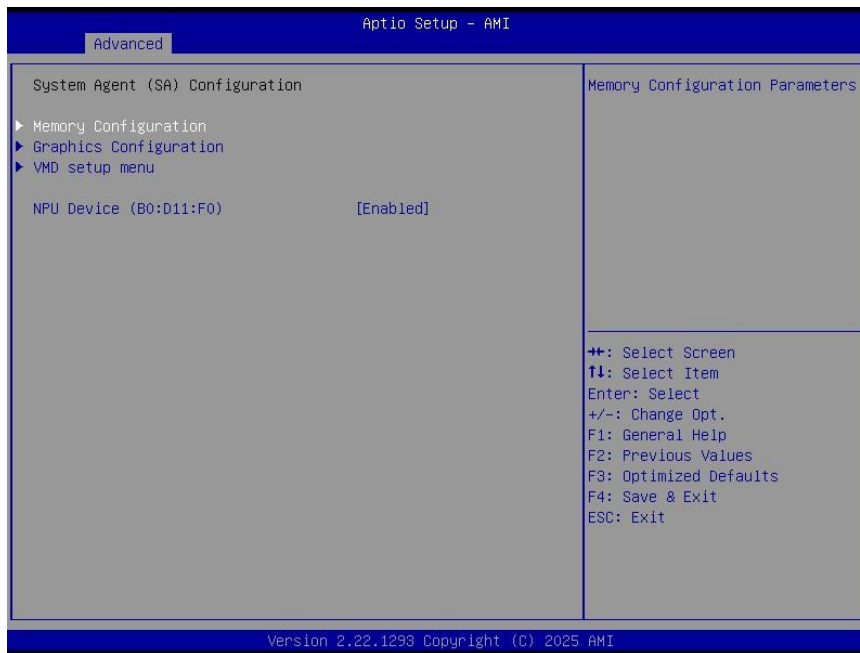

Item	Options	Description
NPU Device (B0:D11:F0)	Enabled[Default] Disabled	Enable/Disable NPU (Neural Processing Unit) Device.

5.6.2.4.1 Memory Configuration

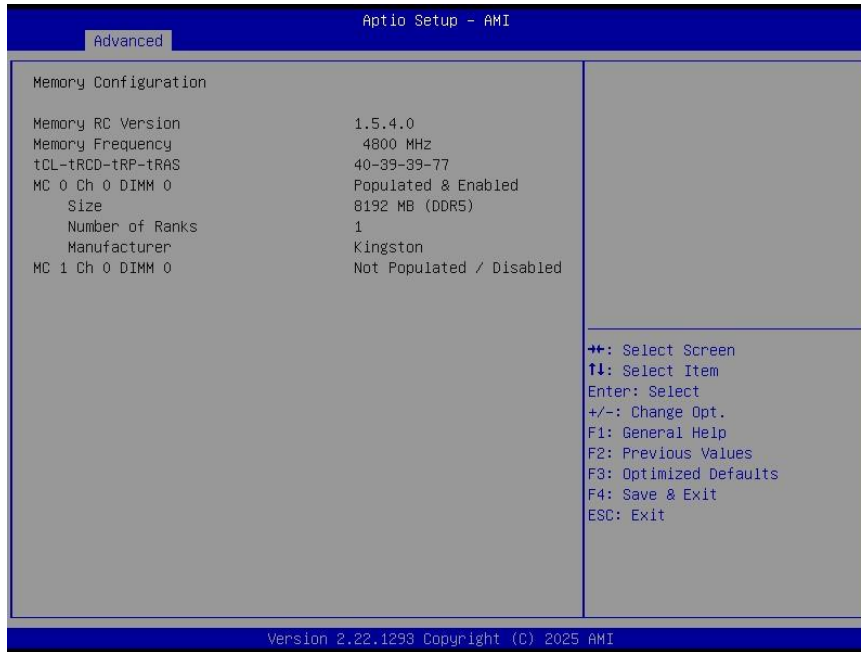

5.6.2.4.2 Graphics Configuration



Item	Options	Description
Primary Display	Auto[Default] IGFX	Select AUTO set IGD to be Primary Display if no external Graphics Device connected otherwise external Graphics Device detected on first PCIe port will be Primary Display or Select IGFX for IGD to be Primary Display Or Select HG for Hybrid Gfx.

5.6.2.4.3 VMD setup menu



Item	Options	Description
Enable VMD controller	Disabled[Default] Enabled	Enable/Disable VMD controller

5.6.2.5 PCIE Configuration



5.6.2.5.1 PCI Express Root Port PXPA3(M.2 KeyE)

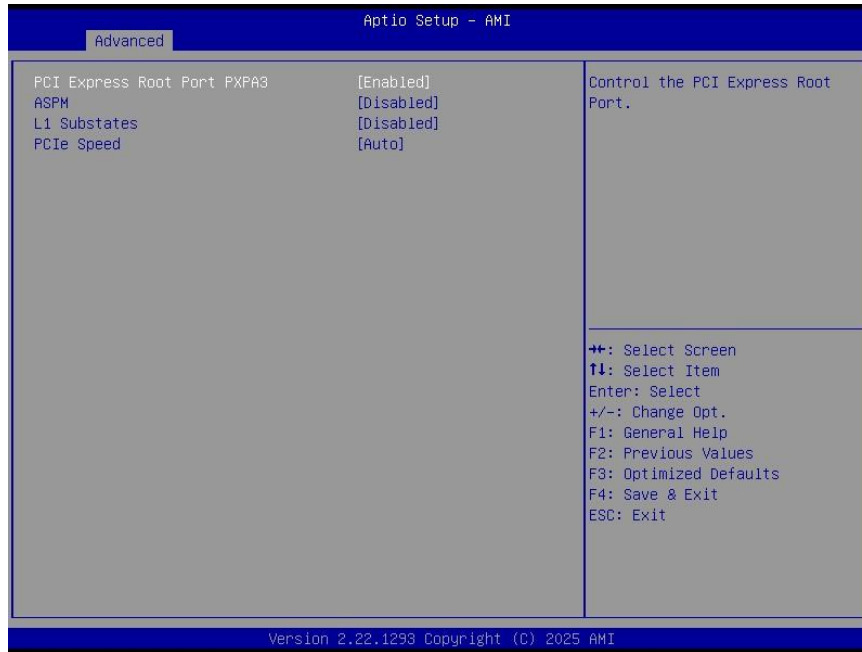

Item	Options	Description
PCI Express Root Port PXPA3	Disabled Enabled [Default]	Control the PCI Express Root Port.
ASPM	Disabled [Default] L0s L1 L0sL1 Auto	Set the ASPM Level: Force L0s – Force all links to L0s State AUTO – BIOS auto configure DISABLE – Disables ASPM
L1 Substates	Disabled [Default] L1.1 L1.1&L1.2	PCI Express L1 Substates settings.
PCIe Speed	Auto [Default] Gen1 Gen2 Gen3 Gen4 Gen5	Configure PCIe Speed

5.6.2.5.2 PCI Express Root Port PXPB1(M.2 KeyB)

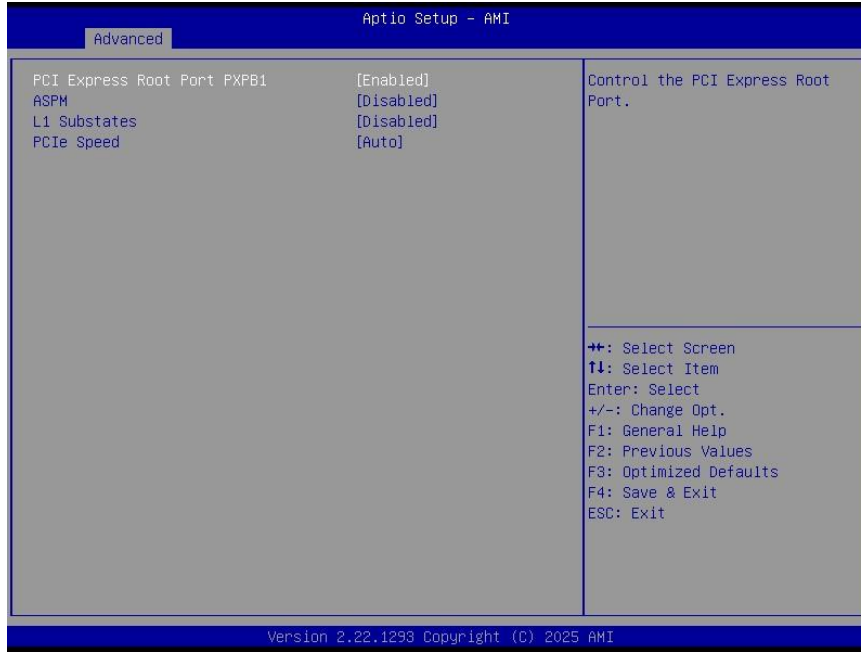

Item	Options	Description
PCI Express Root Port PXPB1	Disabled Enabled[Default]	Control the PCI Express Root Port.
ASPM	Disabled[Default] L0s L1 L0sL1 Auto	Set the ASPM Level: Force L0s – Force all links to L0s State AUTO – BIOS auto configure DISABLE – Disables ASPM
L1 Substates	Disabled[Default] L1.1 L1.1&L1.2	PCI Express L1 Substates settings.
PCIe Speed	Auto[Default] Gen1 Gen2 Gen3 Gen4 Gen5	Configure PCIe Speed

5.6.2.5.3 PCI Express Root Port PXPB3(LAN1-I226)

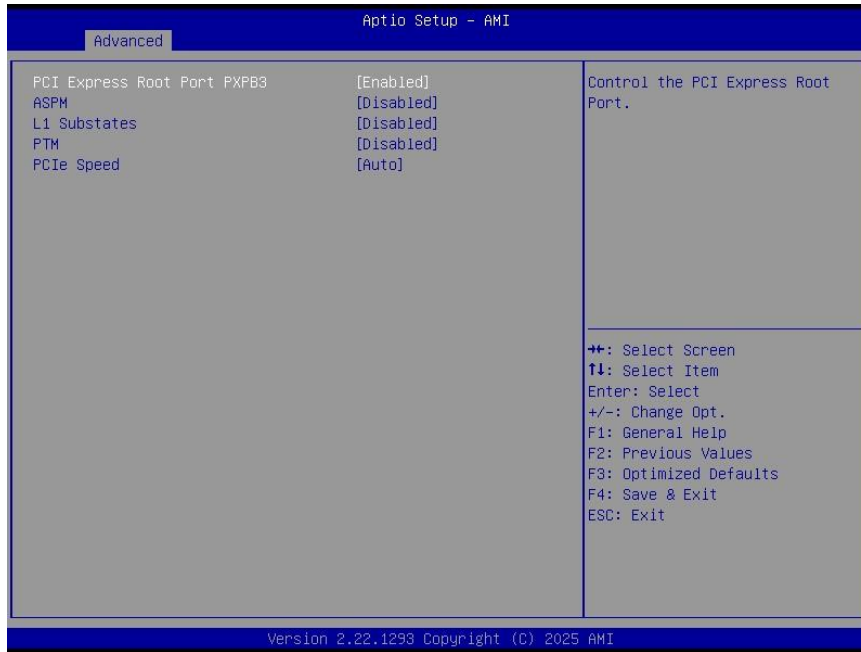

Item	Options	Description
PCI Express Root Port PXPB3	Disabled Enabled[Default]	Control the PCI Express Root Port.
ASPM	Disabled[Default] L0s L1 L0sL1 Auto	Set the ASPM Level: Force L0s – Force all links to L0s State AUTO – BIOS auto configure DISABLE – Disables ASPM
L1 Substates	Disabled[Default] L1.1 L1.1&L1.2	PCI Express L1 Substates settings.
PCIe Speed	Auto[Default] Gen1 Gen2 Gen3 Gen4 Gen5	Configure PCIe Speed

5.6.2.5.4 PCI Express Root Port PXPB4(LAN2-I226)

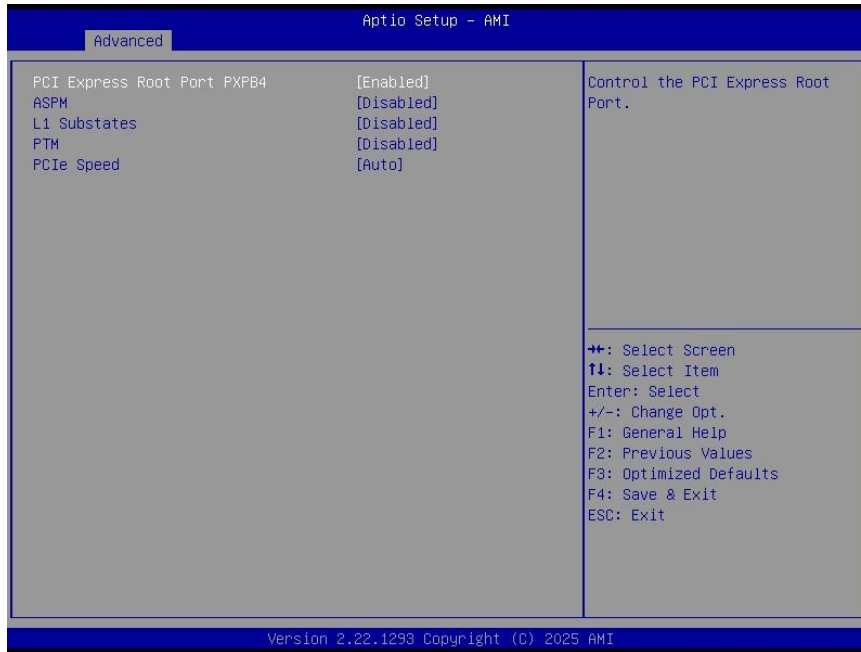

Item	Options	Description
PCI Express Root Port PXPB4	Disabled Enabled[Default]	Control the PCI Express Root Port.
ASPM	Disabled[Default] L0s L1 L0sL1 Auto	Set the ASPM Level: Force L0s – Force all links to L0s State AUTO – BIOS auto configure DISABLE – Disables ASPM
L1 Substates	Disabled[Default] L1.1 L1.1&L1.2	PCI Express L1 Substates settings.
PCIe Speed	Auto[Default] Gen1 Gen2 Gen3 Gen4 Gen5	Configure PCIe Speed

5.6.2.5.5 PCI Express Root Port PXPC(PCIE slot)



Item	Options	Description
PCI Express Root Port PXPC	Disabled Enabled[Default]	Control the PCI Express Root Port.
ASPM	Disabled[Default] L0s L1 L0sL1 Auto	Set the ASPM Level: Force L0s – Force all links to L0s State AUTO – BIOS auto configure DISABLE – Disables ASPM
L1 Substates	Disabled[Default] L1.1 L1.1&L1.2	PCI Express L1 Substates settings.
PCIe Speed	Auto[Default] Gen1 Gen2 Gen3 Gen4 Gen5	Configure PCIe Speed

5.6.2.5.6 PCI Express Root Port PXP(M.2 KeyM1)

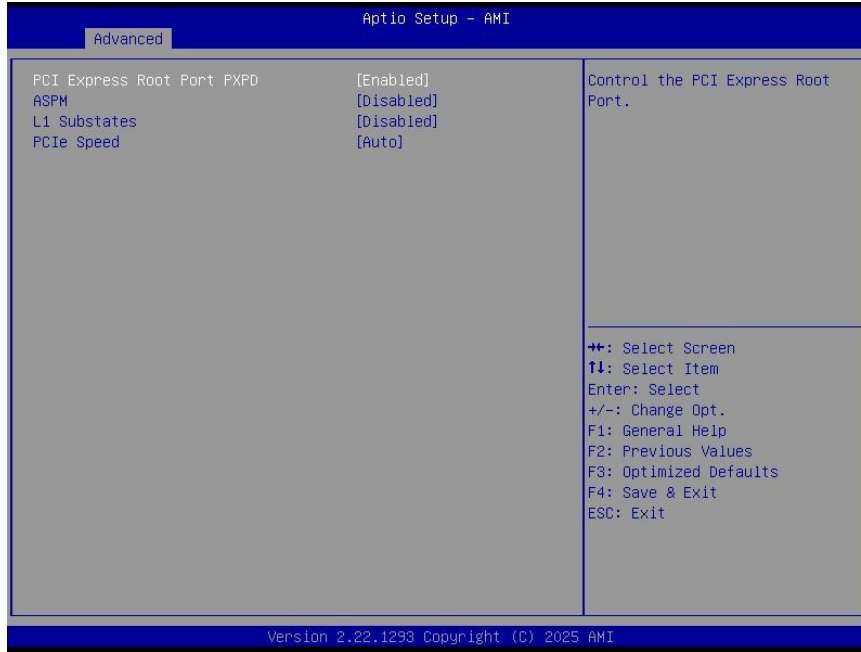

Item	Options	Description
PCI Express Root Port PXP	Disabled Enabled[Default]	Control the PCI Express Root Port.
ASPM	Disabled[Default] L0s L1 L0sL1 Auto	Set the ASPM Level: Force L0s – Force all links to L0s State AUTO – BIOS auto configure DISABLE – Disables ASPM
L1 Substates	Disabled[Default] L1.1 L1.1&L1.2	PCI Express L1 Substates settings.
PCIe Speed	Auto[Default] Gen1 Gen2 Gen3 Gen4 Gen5	Configure PCIe Speed

5.6.2.5.7 PCI Express Root Port PXPE(M.2 KeyM2)

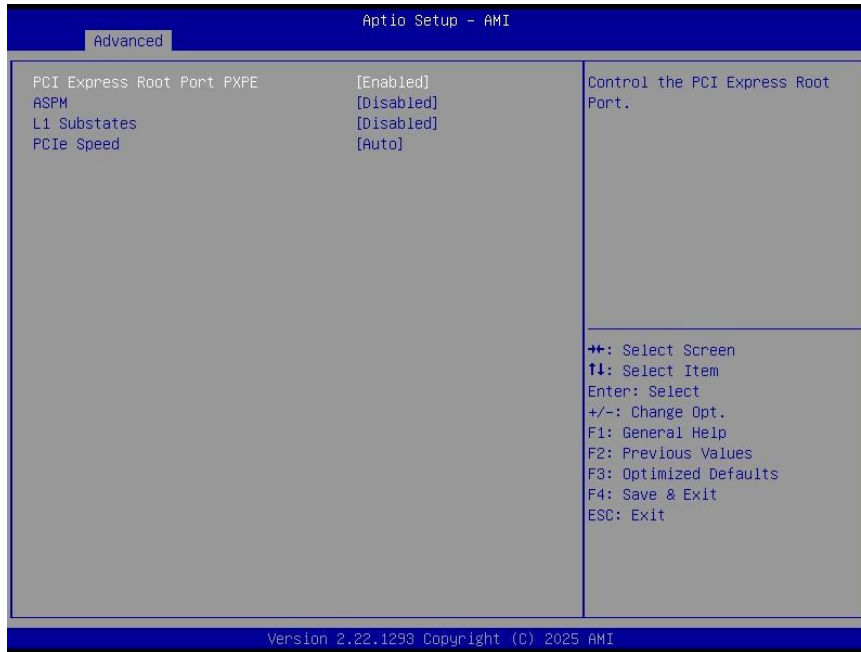

Item	Options	Description
PCI Express Root Port PXPE	Disabled Enabled[Default]	Control the PCI Express Root Port.
ASPM	Disabled[Default] L0s L1 L0sL1 Auto	Set the ASPM Level: Force L0s – Force all links to L0s State AUTO – BIOS auto configure DISABLE – Disables ASPM
L1 Substates	Disabled[Default] L1.1 L1.1&L1.2	PCI Express L1 Substates settings.
PCIe Speed	Auto[Default] Gen1 Gen2 Gen3 Gen4 Gen5	Configure PCIe Speed

5.6.2.6 PCH-IO Configuration



5.6.2.6.1 SATA Configuration

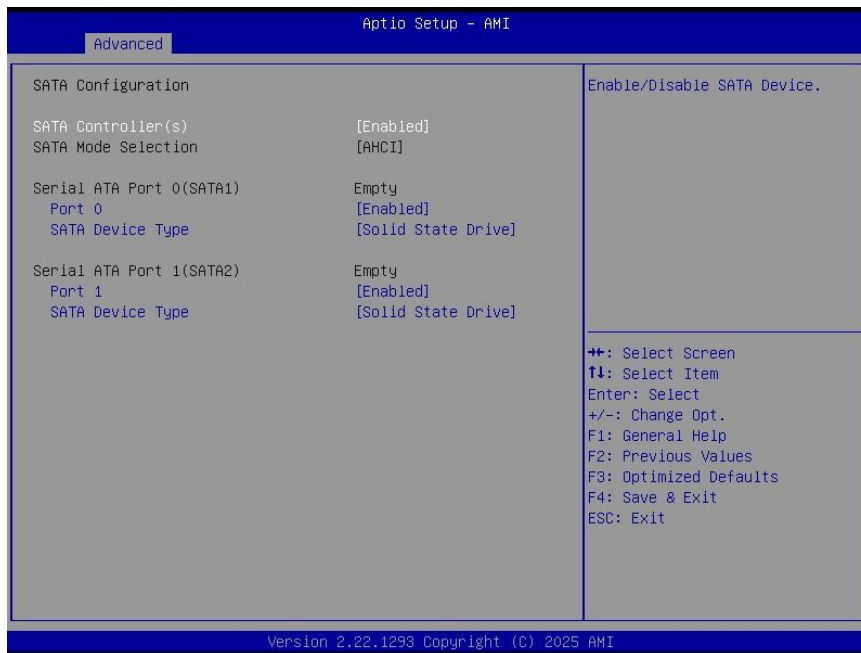

Item	Options	Description
SATA Controller(s)	Enabled[Default] Disabled	Enable/Disable SATA Device.
Port 0/1	Disabled Enabled[Default]	Enable/Disable SATA Port
SATA Device Type	Hard Disk Drive Solid State Drive[Default]	Identify the SATA port is connected to Solid State Drive or Hard Disk Drive

5.6.2.6.2 HD Audio Configuration

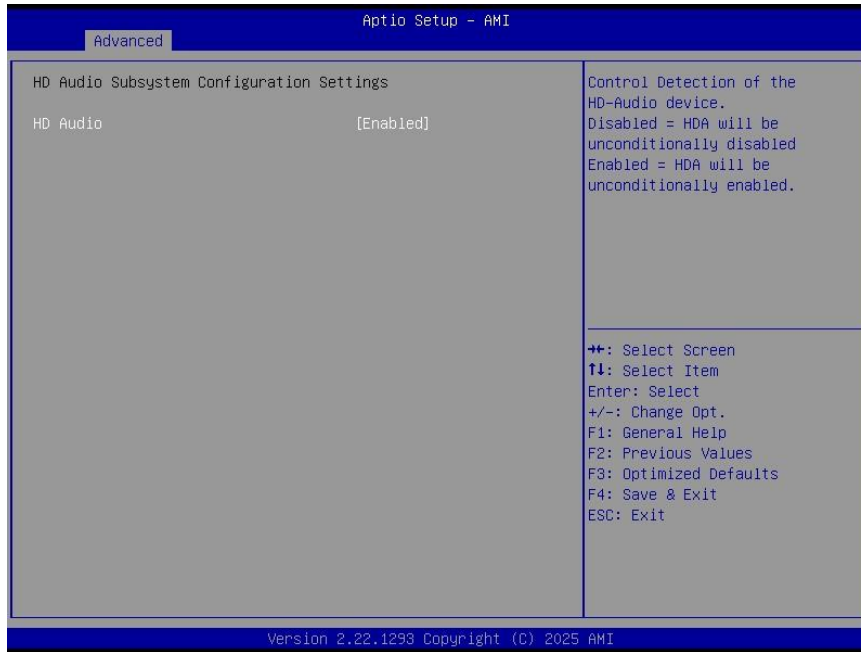

Item	Options	Description
HD Audio	Disabled Enabled[Default]	Control Detection of the HD-Audio device. Disabled = HDA will be unconditionally disabled Enabled = HDA will be unconditionally enabled.

5.6.2.7 PCH-FW Configuration

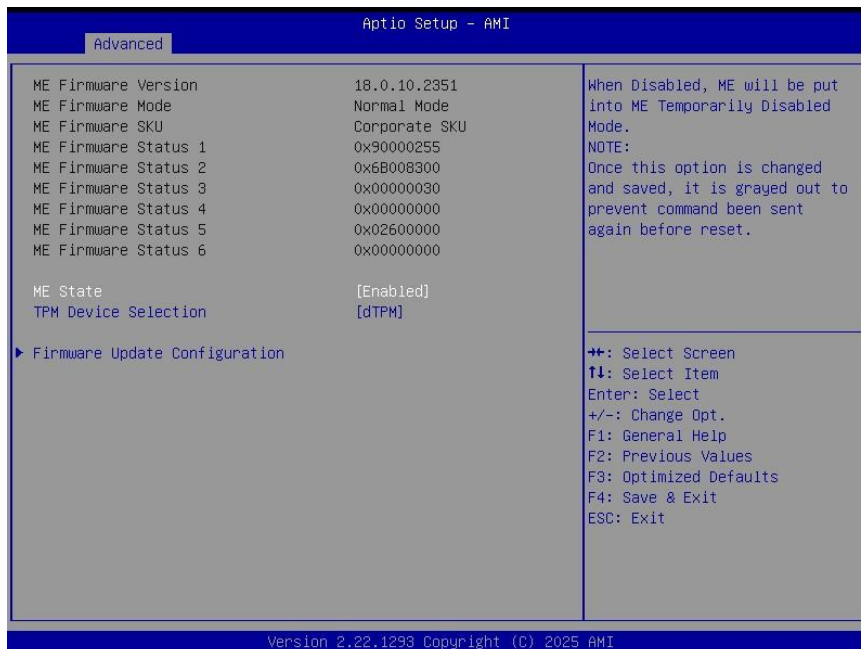

Item	Options	Description
ME State	Disabled Enabled[Default]	When Disabled, ME will be put into ME Temporarily Disabled Mode. NOTE: Once this option is changed and saved, it is grayed out to prevent command from being sent again before reset.

<p>TPM Device Selection</p>	<p>dTPM[Default] PTT</p>	<p>Selects TPM device: PTT or dTPM. PTT – Enables PTT in SkuMgr dTPM 1.2 – Disables PTT in SkuMgr Warning! PTT/dTPM will be disabled and all data saved on it will be lost.</p>
------------------------------------	------------------------------	---

5.6.2.7.1 Firmware Update Configuration

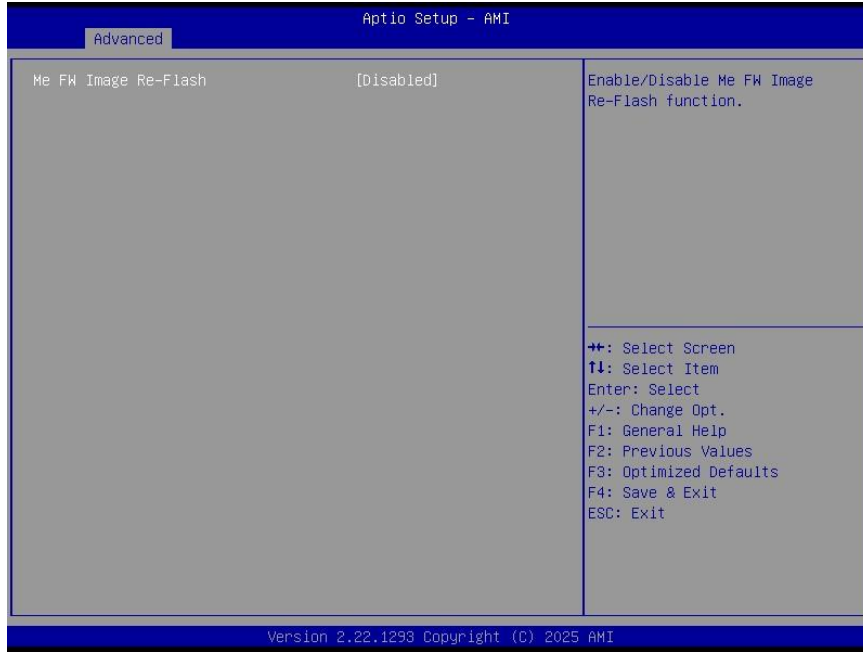

Item	Options	Description
<p>Me FW Image Re-Flash</p>	<p>Disabled[Default] Enabled</p>	<p>Enable/Disable Me FW Image Re-Flash function.</p>

5.6.2.8 Trusted Computing



Item	Options	Description
Security Device Support	Disable Enable[Default]	Enables or Disables BIOS support for security device. O.S. will not show Security Device. TCG EFI protocol and INT1A interface will not be available.

5.6.2.9 ACPI Settings

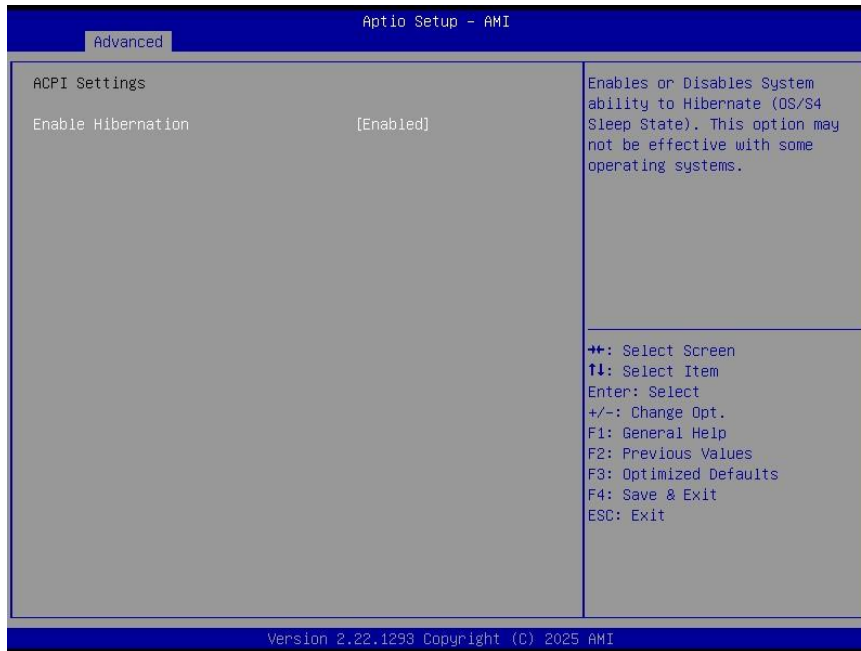

Item	Options	Description
Enable Hibernation	Disabled Enabled[Default],	Enables or Disables System ability to Hibernate (OS/S4 Sleep State). This option may not be effective with some OS.

5.6.2.10 Board & Panel Configuration



APC-2146

Item	Options	Description
Panel Brightness Control Method	BIOS OS driver[Default]	Panel Brightness Control Method. 1. BIOS 2. OS Driver
Power Off mode(EU 2013/617)	Traditional S5[Default] Off mode with WOLan1 Off mode w/o WOL(ErP)	Power Off mode (EU 2013/617).
PWR-On After PWR-Fail	Off[Default] On Last start	AC loss resume.
Wake Up by Ring	Disabled Enabled[Default]	Wake Up by Ring from S4/S5
Watch Dog	Disabled[Default] 30 Sec 40 Sec 50 Sec 1 Min 2 Min 10 Min 20 Min	Select WatchDog.
USB Standby Power	Disabled Enabled[Default]	Enabled/Disabled USB Standby Power during S4/S5

5.6.2.10.1 SHOW DMI INFO

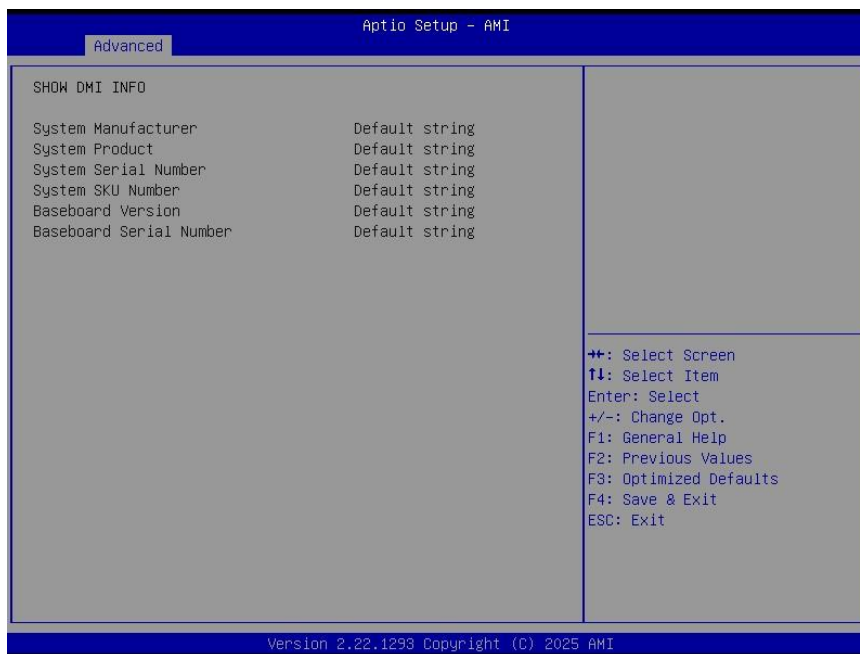

5.6.2.11 EC 5782 HW monitor

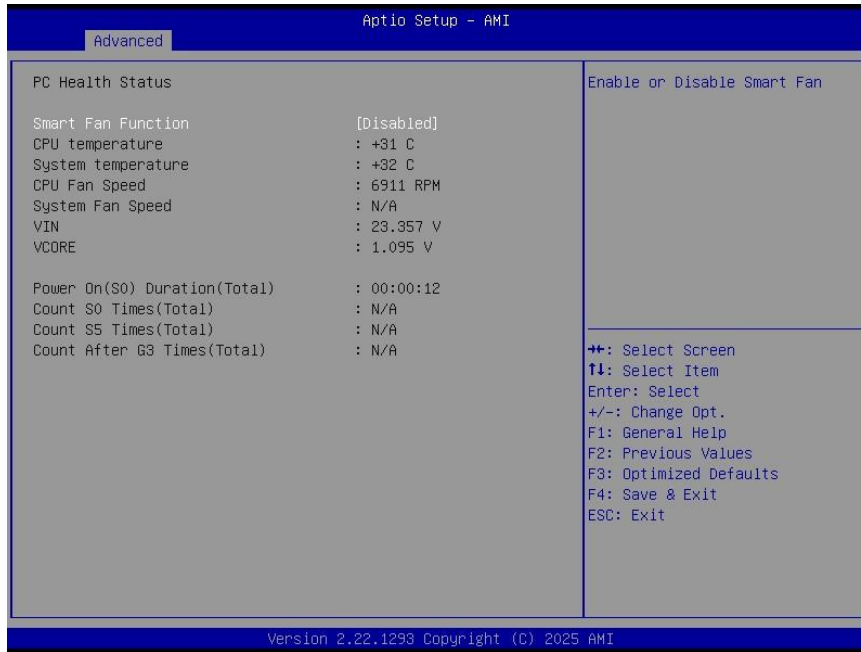

Item	Options	Description
Smart Fan Function	Disabled[Default], Enabled	Enable or Disable Smart Fan

5.6.2.12 S5 RTC Wake Settings



Item	Options	Description
Wake system from S5	Disabled[Default], Fixed Time Dinamic Time	Enable or disable System wake on alarm event. Select FixedTime, system will wake on the hr::min::sec specified. Select DynamicTime, System will wake on the current time + Increase minute(s)

5.6.2.13 Serial Port Console Redirection

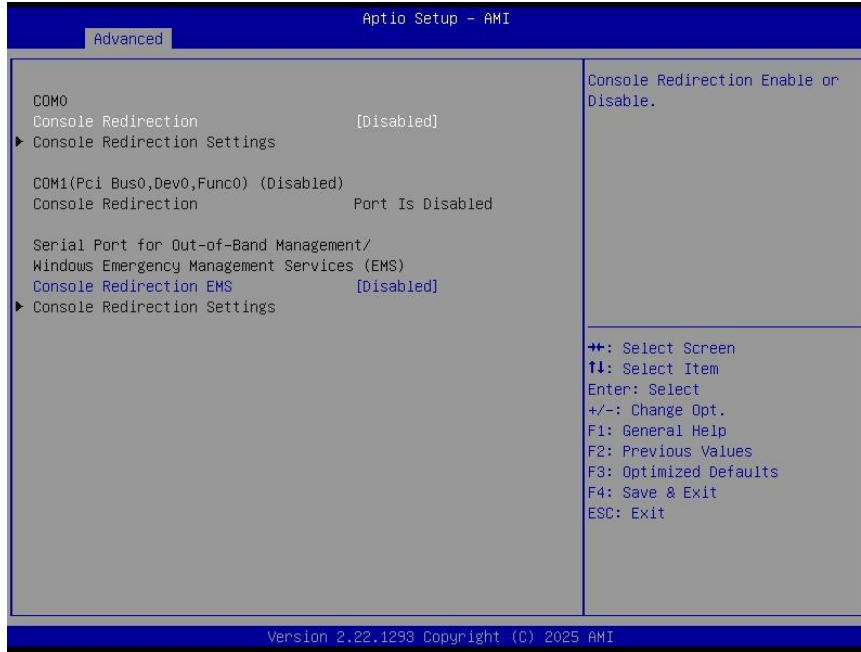

Item	Options	Description
Console Redirection	Disabled[Default], Enabled	Console Redirection Enable or Disable.
Console Redirection EMS	Disabled[Default], Enabled	Console Redirection Enable or Disable.

5.6.2.14 USB Configuration

The USB Configuration menu helps read USB information and configures USB settings.

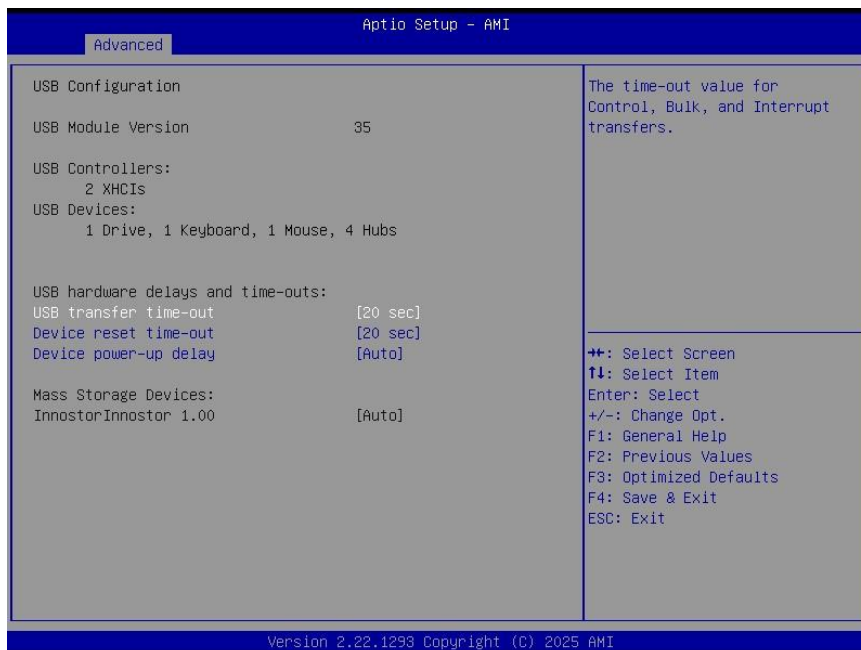

Item	Options	Description
USB transfer time-out	1 sec 5 sec 10 sec 20 sec [Default]	The time-out value for Control, Bulk, and Interrupt transfers.
Device reset time-out	10 sec 20 sec [Default] 30 sec 40 sec	USB mass storage device Start Unit command time-out.
Device power-up delay	Auto [Default] Manual	Maximum time the device will take before it properly reports itself to the Host Controller. 'Auto' uses default value: for a Root port it is 100ms, for a Hub port the delay is taken form Hub descriptor.

5.6.2.15 Network Stack Configuration



Item	Options	Description
Network Stack	Enabled Disabled [Default]	Enable/Disable UEFI Network Stack.

5.6.2.16 NVMe Configuration



5.6.3 Security



- **Administrator Password**

Set setup Administrator Password

- **User Password**

Set User Password

5.6.3.1 Security Boot

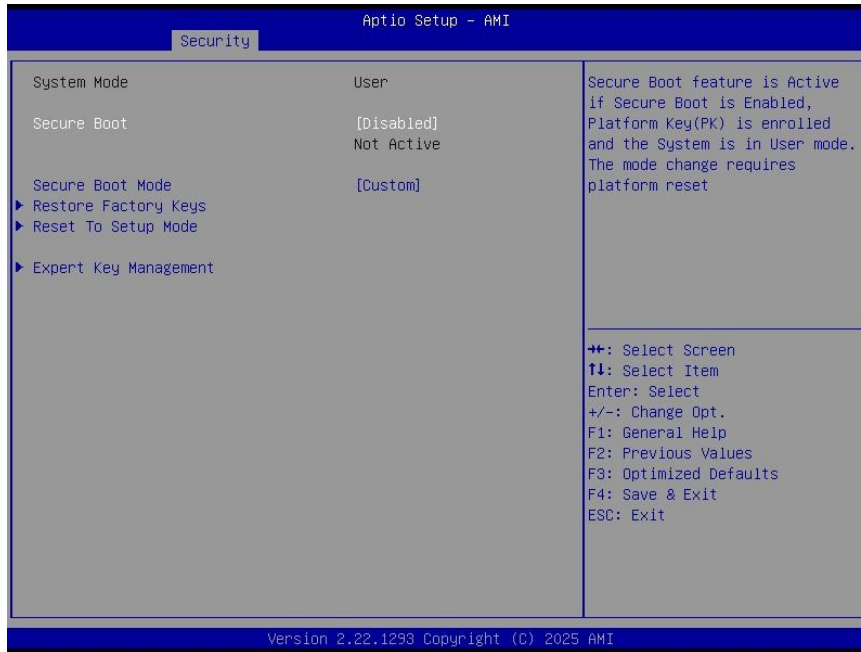

Item	Options	Description
Secure Boot	Disabled Enabled[Default]	Secure Boot feature is Active if Secure Boot is Enabled, Platform Key (PK) is enrolled and the System is in User mode. The mode change requires platform reset
Secure Boot Mode	Standard Custom[Default]	Secure Boot mode options: Standard or Custom. In Custom mode, Secure Boot Policy variables can be configured by a physically present user without full authentication

5.6.3.1.1 Expert Key Management

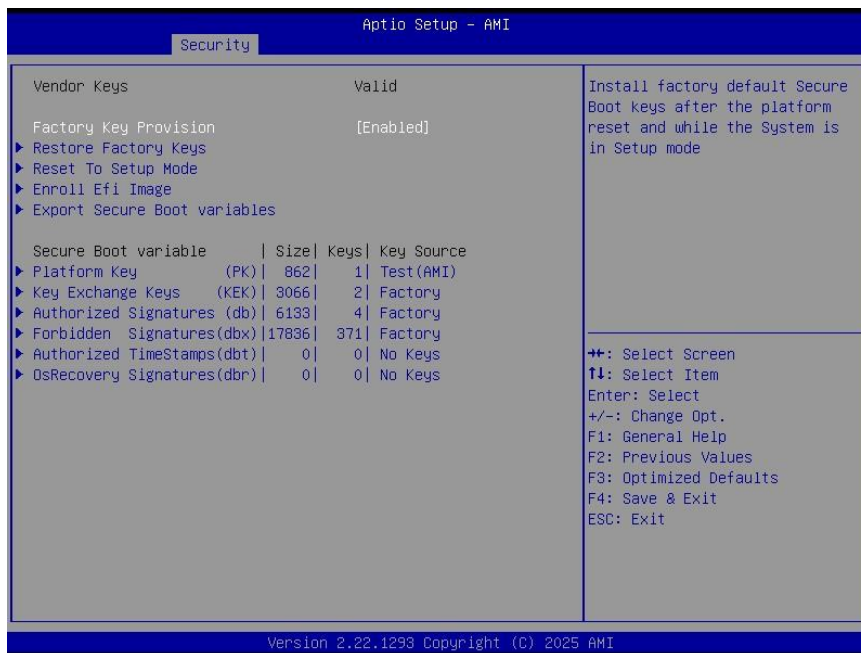

Item	Options	Description
Factory Key Provision	Disabled Enabled[Default]	Install factory default Secure Boot keys after the platform reset and while the System is in Setup mode

5.6.4 Boot

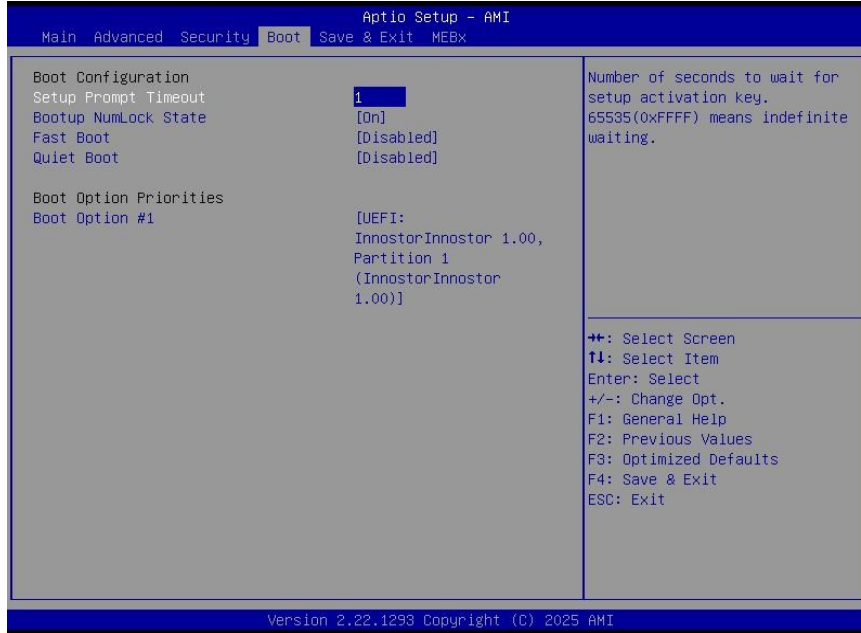

Item	Options	Description
Setup Prompt Timeout	1	Number of seconds to wait for setup activation key. 65535 (0xFFFF) means indefinite waiting.
Bootup NumLock State	On[Default] Off	Select the keyboard NumLock state
Fast Boot	Disabled[Default] Enabled	Enables or disables boot with initialization of a minimal set of devices required to launch active boot option. Has no effect for BBS boot options.
Quiet Boot	Disabled[Default] Enabled	Enables or disables Quiet Boot option
Boot Option #1	Sets the system boot order	

5.6.5 Save and Exit

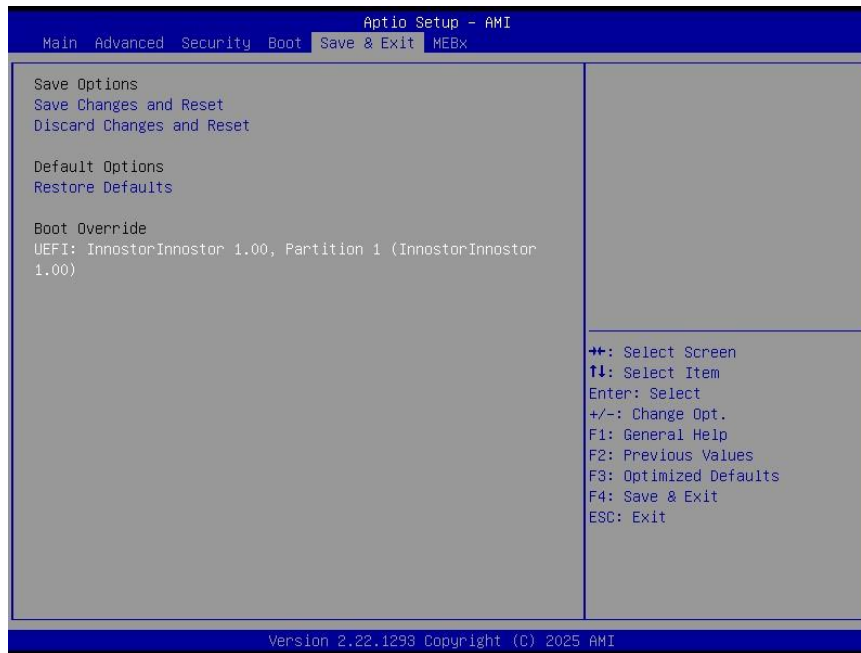

5.6.5.1 Save Changes and Reset

Reset the system after saving the changes.

5.6.5.2 Discard Changes and Reset

Any changes made to BIOS settings during this session of the BIOS setup program are discarded. The setup program then exits and reboots the controller.

5.6.5.3 Restore Defaults

This option restores all BIOS settings to the factory default. This option is useful if the controller exhibits unpredictable behavior due to an incorrect or inappropriate BIOS setting.

5.6.5.4 UEFI: InnostorInnostor 1.00, Partition 1 (Innostor Innostor 1.00)

APC-2146

5.6.6 MEBx



Item	Description
Intel(R) ME Password	MEBx Login

6. Maintenance & Troubleshooting

System Maintenance Introduction

If the components of the product fail they must be replaced.

Please contact the system reseller or vendor to purchase the replacement parts. Please follow the safety precautions outlined in the sections that follow:

General Safety Precautions

Please ensure the following safety precautions are adhered to at all times.

1. Follow the electrostatic precautions outlined below whenever the device is opened.
2. Make sure the power is turned off and the power cord is disconnected whenever the product is being installed, moved or modified.
3. To prevent the risk of electric shock, make sure power cord is unplugged from wall socket. To fully disengage the power to the unit, please disconnect the power cord from the AC outlet. Refer servicing to qualified service personnel. The AC outlet shall be readily available and accessible.
4. Do not apply voltage levels that exceed the specified voltage range. Doing so may cause fire and/or an electrical shock. Use a power cord that matches the voltage of the power outlet, which has been approved and complies with the safety standard of your particular country.
5. Electric shocks can occur if the product chassis is opened when it is running. To avoid risk of electric shock, this device must only be connected to a supply mains with protective earth.
6. Do not drop or insert any objects into the ventilation openings of the product.
7. If considerable amounts of dust, water, or fluids enter the device, turn off the power supply immediately, unplug the power cord, and contact your dealer or the nearest service center.
8. This equipment is not suitable for use in locations where children are likely to be present.
9. DO NOT:
 - Drop the device against a hard surface.
 - Strike or exert excessive force onto the LCD panel.
 - Touch any of the LCD panels with a sharp object.
 - In a site where the ambient temperature exceeds the rated temperature.

Anti-Static Precautions

WARNING:

Failure to take ESD precautions during the installation of the product may result in permanent damage to the product and severe injury to the user.

Electrostatic discharge (ESD) can cause serious damage to electronic components, including the product. Dry climates are especially susceptible to ESD. It is therefore critical that whenever the product is opened and any of the electrical components are handled, the following anti-static precautions are strictly adhered to.

- Wear an anti-static wristband: Wearing a simple anti-static wristband can help to prevent ESD from damaging any electrical component.
 - Self-grounding: Before handling any electrical component, touch any grounded conducting material. During the time the electrical component is handled, frequently touch any conducting materials that are connected to the ground.
 - Use an anti-static pad: When configuring or working with an electrical component, place it on an anti-static pad. This reduces the possibility of ESD damage.
 - Only handle the edges of the electrical component. When handling the electrical component, hold the electrical component by its edges. Please ensure the following safety precautions are adhered to at all times.
1. Follow the electrostatic precautions outlined below whenever the device is opened.
 2. Make sure the power is turned off and the power cord is disconnected

Maintenance and Cleaning

When maintaining or cleaning the product, please follow the guidelines below.

WARNING:

- For safety reasons, turn-off the power and unplug the panel PC before cleaning.
- If you dropped any material or liquid such as water onto the panel PC when cleaning, unplug the power cable immediately and contact your dealer or the nearest service center. Always make sure your hands are dry when unplugging the power cable.

Maintenance and Cleaning

Prior to cleaning any part or component of the product, please read the details below.

- Except for the LCD panel, never spray or squirt liquids directly onto any other components. To clean the LCD panel, gently wipe it with a piece of soft dry cloth or a slightly moistened cloth.
- The interior of the device does not require cleaning. Keep fluids away from the device interior.
- Be cautious of all small removable components when vacuuming the device.
- Never drop any objects or liquids through the openings of the device.
- Be cautious of any possible allergic reactions to solvents or chemicals used when cleaning the device.
- Avoid eating, drinking and smoking within vicinity of the device.

Cleaning Tools

Some components in the panel PC may only be cleaned using a product specifically designed for the purpose. In such case, the product will be explicitly mentioned in the cleaning tips. Below is a list of items to use when cleaning the panel PC.

- Cloth: Although paper towels or tissues can be used, a soft, clean piece of cloth is recommended when cleaning the device.
- Water or rubbing alcohol: A cloth moistened with water or rubbing alcohol can be used to clean the device.
- Using solvents: The use of solvents is not recommended when cleaning the device as they may damage the plastic parts.
- Vacuum cleaner: Using a vacuum specifically designed for computers is one of the best methods of cleaning the device. Dust and dirt can restrict the airflow in the device and cause its circuitry to corrode.
- Cotton swabs: Cotton swabs moistened with rubbing alcohol or water are excellent tools for wiping hard to reach areas.
- Foam swabs: Whenever possible, it is best to use lint free swabs such as foam swabs for cleaning.

Basic Troubleshooting

PEI Beep Codes

# of Beeps	Description
1	Memory not Installed
2	Recovery started
3	Typically for development use. The beep code is generated when DXE IPL PPI or DXE Core is not found.
4	Recovery failed
4	S3 Resume failed
7	Typically for development use. The beep code is generated when platform cannot be reset because reset PPI is not available.

DXE Beep Codes

# of Beeps	Description
1	Invalid password
4	Typically for development use. The beep code is generated when some of the Architectural Protocols are not available.
5	No Console Input or Output Devices are found
5	No Console Input Devices are found
6	Flash update is failed
7	Typically for development use. The beep code is generated when platform cannot be reset because reset protocol is not available.
8	Platform PCI resource requirements cannot be met

Platform Initialization (PI) Boot Phases

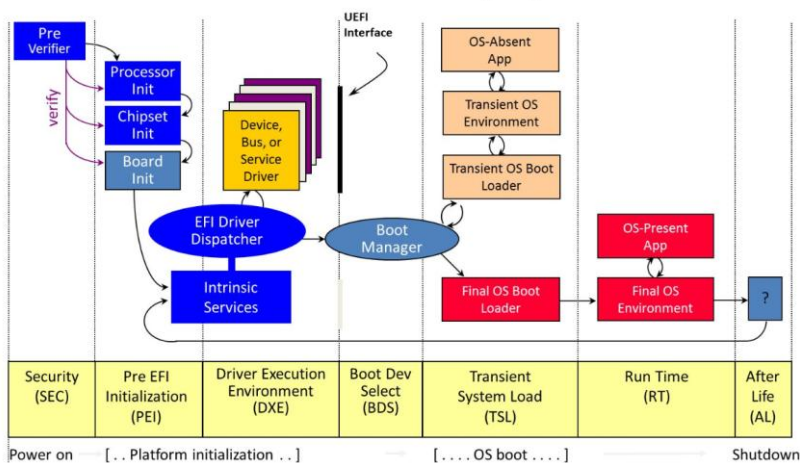

https://uefi.org/specs/PI/1.8/V2_Overview.html

7. Product Application

For detailed instructions on the operation of the Watchdog Timer and Digital I/O (DIO) features of this Panel PC, please refer to the comprehensive guide available in the "AvalueIOAPI" manual. Please reaching out to your respective distributors, Avalue technical support team, or Avalue customer service representatives for further information. Feel free to inquire about this supplementary resource to enhance your understanding of the Watchdog Timer and Digital I/O (DIO) Application for optimal utilization of your Panel PC.

8. Operating the Device

The Multi-Touch mode was pre-installed on the Panel PC and need tools for any customizations. Should you have specific requirements or encounter scenarios where a customized touch mode is necessary, we recommend reaching out to your local distributors, Avalue technical support team, or Avalue customer service representatives. These professionals can provide tailored guidance and assistance to address any unique needs related to Multi-Touch mode adjustments.