

User Manual

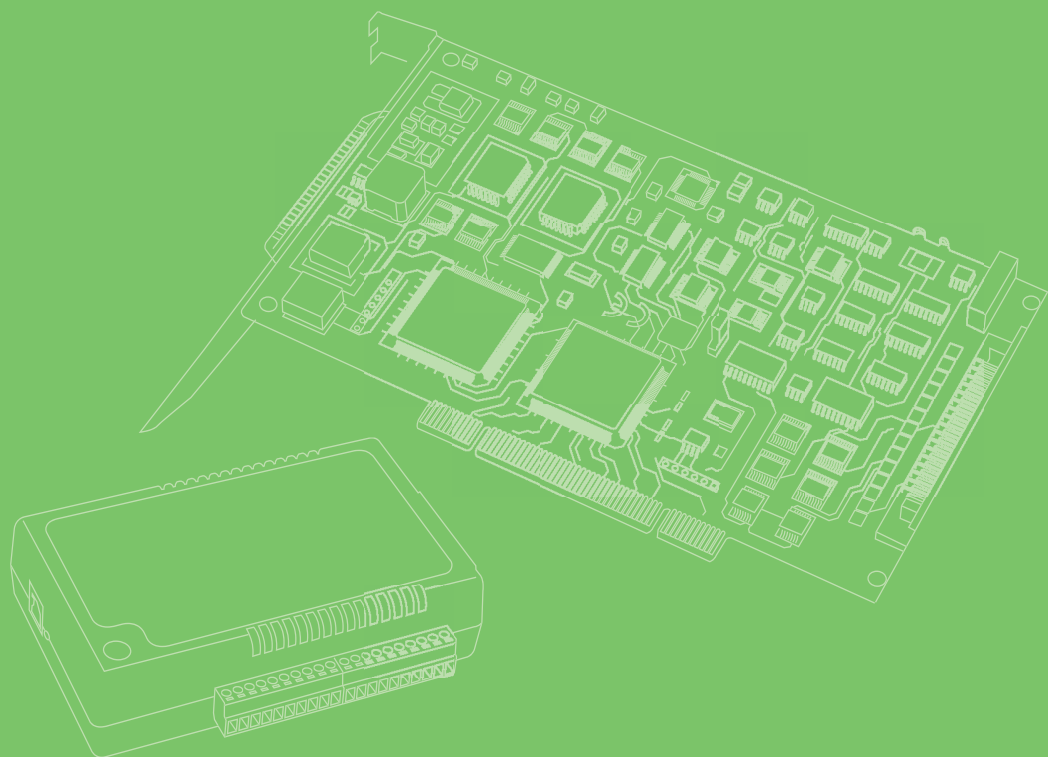

# EKI-1526 Series

16-Port Serial Device Server  
(Rackmount)

**ADVANTECH**

*Enabling an Intelligent Planet*

---

## Copyright

The documentation and the software included with this product are copyrighted 2025 by Advantech Co., Ltd. All rights are reserved. Advantech Co., Ltd. reserves the right to make improvements in the products described in this manual at any time without notice. No part of this manual may be reproduced, copied, translated, or transmitted in any form or by any means without the prior written permission of Advantech Co., Ltd. The information provided in this manual is intended to be accurate and reliable. However, Advantech Co., Ltd. assumes no responsibility for its use, nor for any infringements of the rights of third parties that may result from its use.

## Acknowledgments

Intel and Pentium are trademarks of Intel Corporation.

Microsoft Windows and MS-DOS are registered trademarks of Microsoft Corp.

All other product names or trademarks are properties of their respective owners.

## Product Warranty (5 years)

Advantech warrants the original purchaser that each of its products will be free from defects in materials and workmanship for five years from the date of purchase.

This warranty does not apply to any products that have been repaired or altered by persons other than repair personnel authorized by Advantech, or products that have been subject to misuse, abuse, accident, or improper installation. Advantech assumes no liability under the terms of this warranty as a consequence of such events.

Because of Advantech's high quality-control standards and rigorous testing, most customers never need to use our repair service. If an Advantech product is defective, it will be repaired or replaced free of charge during the warranty period. For out-of-warranty repairs, customers will be billed according to the cost of replacement materials, service time, and freight. Please consult your dealer for more details.

If you believe your product is defective, follow the steps outlined below.

1. Collect all the information about the problem encountered. (For example, CPU speed, Advantech products used, other hardware and software used, etc.) Note anything abnormal and list any onscreen messages displayed when the problem occurs.
2. Call your dealer and describe the problem. Please have your manual, product, and any helpful information readily available.
3. If your product is diagnosed as defective, obtain a return merchandise authorization (RMA) number from your dealer. This allows us to process your return more quickly.
4. Carefully pack the defective product, a completed Repair and Replacement Order Card, and a proof of purchase date (such as a photocopy of your sales receipt) into a shippable container. Products returned without a proof of purchase date are not eligible for warranty service.
5. Write the RMA number clearly on the outside of the package and ship the package prepaid to your dealer.

# Declaration of Conformity

## CE

This product has passed the CE test for environmental specifications when shielded cables are used for external wiring. We recommend the use of shielded cables. This type of cable is available from Advantech. Please contact your local supplier for ordering information.

Test conditions for passing also include the equipment being operated within an industrial enclosure. In order to protect the product from damage caused by electrostatic discharge (ESD) and EMI leakage, we strongly recommend the use of CE-compliant industrial enclosure products.

## FCC Class A

This equipment has been tested and found to comply with the limits for a Class A digital device, pursuant to part 15 of the FCC Rules. These limits are designed to provide reasonable protection against harmful interference when the equipment is operated in a commercial environment. This equipment generates, uses, and can radiate radio frequency energy and, if not installed and used in accordance with the instruction manual, may cause harmful interference to radio communications. Operation of this equipment in a residential area is likely to cause harmful interference. In this event, users are required to correct the interference at their own expense.

# Technical Support and Assistance

1. Visit the Advantech website at [www.advantech.com/support](http://www.advantech.com/support) to obtain the latest product information.
2. Contact your distributor, sales representative, or Advantech's customer service center for technical support if you need additional assistance. Please have the following information ready before calling:
  - Product name and serial number
  - Description of your peripheral attachments
  - Description of your software (operating system, version, application software, etc.)
  - A complete description of the problem
  - The exact wording of any error messages

# Warnings, Cautions, and Notes

**Warning!** Warnings indicate conditions that if not observed can cause personal injury!



**Caution!** Cautions are included to help prevent hardware damage and data losses. E.g.



“Batteries are at risk of exploding if incorrectly installed. Do not attempt to recharge, force open, or heat the battery. Replace the battery only with the same or equivalent type as recommended by the manufacturer. Discard used batteries according to the manufacturer’s instructions.”

**Note!** Notes provide additional optional information.



## Document Feedback

To assist us with improving this manual, we welcome all comments and constructive criticism. Please send all such feedback in writing to [support@advantech.com](mailto:support@advantech.com).

## Packing List

Before system installation, check that the items listed below are included and in good condition. If any item does not accord with the list, contact your dealer immediately.

- 1 x Device Server
- 1 x Rack mount kits, including two L-shape metal plates and twelve screws

## Optional Accessories

Part Number	Description
OPT1J-AE	30cm RJ45 to DB9 (male) cable
1702002600	Power Cable US Plug 1.8m
1702002605	Power Cable EU Plug 1.8m
1702031801-11	Power Cable UK Plug 1.8m
1700000596-11	Power Cable China Plug 1.8m
1702031836	Power Cable Australia Plug 1.8m

# Safety Instructions

1. Read these safety instructions carefully.
2. Retain this user manual for future reference.
3. Disconnect the equipment from all power outlets before cleaning. Use only a damp cloth for cleaning. Do not use liquid or spray detergents.
4. For pluggable equipment, the power outlet socket must be located near the equipment and easily accessible.
5. Protect the equipment from humidity.
6. Place the equipment on a reliable surface during installation. Dropping or letting the equipment fall may cause damage.
7. The openings on the enclosure are for air convection. Protect the equipment from overheating. Do not cover the openings.
8. Ensure that the voltage of the power source is correct before connecting the equipment to a power outlet.
9. Position the power cord away from high-traffic areas. Do not place anything over the power cord.
10. All cautions and warnings on the equipment should be noted.
11. If the equipment is not used for a long time, disconnect it from the power source to avoid damage from transient overvoltage.
12. Never pour liquid into an opening. This may cause fire or electrical shock.
13. Never open the equipment. For safety reasons, the equipment should be opened only by qualified service personnel.
14. If any of the following occurs, have the equipment checked by service personnel:
  - The power cord or plug is damaged.
  - Liquid has penetrated the equipment.
  - The equipment has been exposed to moisture.
  - The equipment is malfunctioning, or does not operate according to the user manual.
  - The equipment has been dropped and damaged.
  - The equipment show obvious signs of breakage.
15. Do not leave the equipment in an environment with a storage temperature of below  $-40^{\circ}\text{C}$  ( $-40^{\circ}\text{F}$ ) or above  $85^{\circ}\text{C}$  ( $185^{\circ}\text{F}$ ) as this may damage the components. The equipment should be kept in a controlled environment.
16. In accordance with IEC 704-1:1982 specifications, the sound pressure level at the operator's position does not exceed 70 dB (A).

**DISCLAIMER:** These instructions are provided according to IEC 704-1 standards. Advantech disclaims all responsibility for the accuracy of any statements contained herein.

---

## Safety Precautions - Static Electricity

Follow these simple precautions to protect yourself from harm and the products from damage.

- To avoid electrical shock, always disconnect the power from the PC chassis before manual handling. Do not touch any components on the CPU card or other cards while the PC is powered on.
- Disconnect the power before making any configuration changes. A sudden rush of power after connecting a jumper or installing a card may damage sensitive electronic components.

## Safety Precaution-Power Cord Safety

Please read the following safety information carefully before installing the Serial Device Server:

**Warning!** *Installation and removal of the unit must be carried out by qualified personnel only.*



- The unit must be connected to an earthed (grounded) outlet to comply with international safety standards.
- The unit must be powered by using listed power source, rated 12-48Vdc, 0.7A minimum and Tma 75'C comply with LPS or PS2.
- Do not connect the unit to an A.C, outlet (power supply) without an earth (ground) connection.
- The socket outlet must be near to the unit and easily accessible, You can only remove power from the unit by disconnecting the power cord from the outlet.

## Safety Precaution -Shock Hazard

Electrical current from power, telephone, and communication cables is hazardous.To avoid a shock hazard:

- Do not connect or disconnect any cables or perform installation, maintenance, or reconfiguration of this product during an electrical storm.
- Connect all power cords to a properly wired and grounded power source.
- Connect to properly wired power sources any equipment that will be attached to this product.
- When possible, use one hand only to connect or disconnect signal cables.Never turn on any equipment when there is evidence of fire, water, or structural damage.
- Disconnect the attached Ac power cords, Dc power sources, network connections, telecommunications systems, and serial cables before you open the device covers, unless you are instructed otherwise in the installation and configuration procedures.
- Connect and disconnect cables as described in the following table when you install, move, or open covers on this product or attached devices.

# Contents

<b>Chapter 1</b>	<b>Introduction.....</b>	<b>1</b>
1.1	Overview .....	2
1.2	Device Features .....	2
1.3	Specifications .....	3
	Table 1.1: Specifications .....	3
<b>Chapter 2</b>	<b>Getting Started.....</b>	<b>5</b>
2.1	Hardware Overview.....	6
2.1.1	Front View .....	6
	Figure 2.1 Front View .....	6
	Table 2.1: Front View .....	6
2.1.2	Rear View .....	6
	Figure 2.2 Rear View .....	6
	Table 2.2: .....	6
	Table 2.3: Rear View .....	6
2.1.3	LED Indicators .....	6
	Figure 2.3 System LED Panel .....	6
	Table 2.4: LED Indicators .....	7
2.1.4	Dimensions .....	7
	Figure 2.4 EKI-1526N Dimensions .....	7
2.2	Connecting Hardware .....	8
2.2.1	Rack Mount.....	8
	Figure 2.5 Installing the Rack Mount Brackets .....	8
	Figure 2.6 Installing the Serial Device Server.....	9
2.2.2	Serial Connection.....	10
	Table 2.5: EKI-1526N Serial Port Pin Assignments .....	10
	Figure 2.7 RJ45 Plug & RJ45 Connector Pin Assignment.....	10
	Figure 2.8 RJ45 to DB9 Cable Assignment .....	10
	Figure 2.9 RJ45 to DB9 (Male) Cable.....	10
2.2.3	Power Connection.....	11
	Figure 2.10Connecting AC Power .....	12
<b>Chapter 3</b>	<b>Utility Configuration .....</b>	<b>13</b>
3.1	Configuration Utility Overview .....	14
3.2	Installing the Configuration Utility.....	14
3.2.1	Installing the Software.....	14
	Figure 3.1 InstallShield Wizard 1 of 4 .....	15
	Figure 3.2 InstallShield Wizard 2 of 4 .....	15
	Figure 3.3 InstallShield Wizard 3 of 4 .....	16
	Figure 3.4 InstallShield Wizard 4 of 4 .....	16
3.3	Menu Bar.....	17
	Figure 3.5 Configuration Utility Overview .....	17
	Table 3.1: Configuration Utility Overview .....	17
3.4	Quick Tool Bar .....	18
	Figure 3.6 Quick Tool Bar Overview.....	18
	Table 3.2: Quick Tool Bar Overview.....	18
3.5	Utility Settings .....	19
3.5.1	Utility Settings .....	19
	Figure 3.7 View > Settings > Main Form Setting .....	19
	Table 3.3: Main Form Setting .....	19
	Figure 3.8 View > Settings > Device Manager .....	20

	Table 3.4: Device Manager .....	20
3.5.2	Discovering Your Device Server .....	21
	Figure 3.9 Network .....	21
	Figure 3.10 Open View of Serial Device Configuration Utility .....	21
	Figure 3.11 Selecting a Device .....	22
	Figure 3.12 Viewing Basic Settings .....	23
3.5.3	Network Settings .....	23
	Figure 3.13 Utility Overview .....	24
	Figure 3.14 Network Settings Overview .....	24
	Table 3.5: Network Settings .....	25
3.6	Administrator Settings .....	26
3.6.1	Locate the Serial Device Server .....	26
	Figure 3.15 Locate the Serial Device Server .....	26
3.6.2	Securing the Serial Device Server .....	26
	Figure 3.16 Lock the Serial Device Server .....	27
	Figure 3.17 Enter a Password .....	27
	Figure 3.18 Reset Device .....	28
	Figure 3.19 Unlock the Serial Device Server .....	28
3.6.3	Restore to Factory Default Settings .....	29
	Figure 3.20 Restore to Factory Default Settings .....	29
3.6.4	Resetting the Device .....	29
	Figure 3.21 Reset Device .....	30
3.6.5	Add to Favorite .....	30
	Figure 3.22 Add to Favorite .....	30
3.6.6	Auto Mapping .....	31
3.6.7	Manual Mapping .....	31
3.7	Create CA .....	31

## Chapter 4 Selecting An Operating Mode ..... 35

4.1	Overview .....	36
4.2	COM Port Redirector (Virtual COM Port) .....	36
	Figure 4.1 Virtual COM Mode .....	36
	Figure 4.2 Configuring Virtual COM Mode .....	37
4.2.1	Normal Mode .....	37
4.2.2	Round-Robin Mode .....	37
4.3	USDG Data Mode .....	38
4.3.1	USDG TCP Client Mode .....	38
	Figure 4.3 USDG TCP Client Mode .....	39
	Figure 4.4 Peers for Receiving Data .....	39
4.3.2	USDG Data TCP Server mode .....	39
	Figure 4.5 USDG TCP Server Mode .....	40
	Figure 4.6 USDG Data Mode .....	40
4.3.3	USDG UDP Server/Client Mode .....	40
4.4	USDG Control Mode .....	41
	Figure 4.7 USDG Control Mode .....	41
4.4.1	Hangup Character .....	41
4.4.2	Guard Time .....	42
	Table 4.1: Guard Time .....	42
4.5	RFC2217 Mode .....	42
4.6	SSH Console Mode .....	42

## Chapter 5 Setting up Virtual COM ..... 43

5.1	Setting COM Port Redirector .....	44
5.2	Virtual COM Port Mapping .....	44
5.2.1	Auto Mapping .....	44
	Figure 5.1 Selecting Auto Mapping .....	44
	Figure 5.2 Selecting Auto Mapping .....	45

	Figure 5.3 Mapping Selected Ports .....	45
	Figure 5.4 Viewing VCOM Mapping Results .....	45
5.2.2	Manual Mapping .....	46
	Figure 5.5 Selecting Manual Mapping .....	46
	Figure 5.6 Viewing Manual VCOM Mapping Results.....	46
	Figure 5.7 Viewing Manual VCOM Mapping Results.....	47
5.2.3	Configuration Wizard .....	47
	Figure 5.8 Selecting the Configuration Wizard .....	47
5.2.4	Confirming Virtual COM Settings.....	48
	Figure 5.9 Serial Port Listing on EKI-1526 Series Device .....	48
	Figure 5.10 System Port VCOM Mapping Configuration .....	49
	Figure 5.11 Verifying VCOM Mapping Configuration.....	49
5.2.5	Removing VCOM Ports.....	50
	Figure 5.12 Remove VCOM Port.....	50
5.2.6	Exporting and Importing VCOM Mapping .....	50
5.3	Running a Diagnostic Test .....	51

## **Chapter 6 Web Interface .....53**

6.1	Overview .....	54
6.2	Accessing the Web Page .....	54
	6.2.1 Accessing the Web Page via Configuration Utility .....	54
	Figure 6.1 Accessing the Web Page via Configuration Utility....	54
	6.2.2 Accessing the Web Page via Web Browser.....	55
6.3	System .....	55
	Figure 6.2 System.....	55
	Table 6.1: System.....	56
6.4	Service .....	57
	6.4.1 VCOM .....	57
	Figure 6.3 VCOM 1.0.....	57
	Figure 6.4 VCOM 2.0.....	57
	Table 6.2: VCOM.....	57
	6.4.2 USDG.....	58
	Figure 6.5 USDG1.0 .....	58
	Figure 6.6 USDG 2.0 .....	58
	Table 6.3: USDG .....	59
	6.4.3 Web Server.....	59
	Figure 6.7 Web Server.....	60
	Table 6.4: Web Server.....	60
	6.4.4 SSH Console Setting .....	61
	Figure 6.8 SSH Console Setting .....	61
	Table 6.5: SSH Console Setting .....	61
	6.4.5 LDAP and RADIUS Setting .....	61
	6.4.6 LDAP Setting .....	62
	Figure 6.9 LDAP Setting .....	62
	Table 6.6: LDAP Setting .....	62
	6.4.7 RADIUS Setting .....	63
	Figure 6.10 Radius Setting .....	63
	Table 6.7: Radius Setting .....	63
	6.4.8 User Management .....	63
	Figure 6.11 User Management .....	64
	Table 6.8: User Management .....	64
6.5	Ethernet Configuration .....	65
	Figure 6.12 Ethernet Configuration.....	65
	Table 6.9: Ethernet Configuration.....	65
6.6	Ethernet Bridge .....	66
	Figure 6.13 Ethernet Bridge Configuration .....	66
	Table 6.10: Ethernet Bridge.....	66
6.7	Port Configuration .....	67

6.7.1	Basic	67
	Figure 6.14Port Configuration > Basic	67
	Table 6.11: Basic	67
6.7.2	Operation	68
	Figure 6.15Port Configuration > Operation	68
	Table 6.12: Virtual COM Mode	68
	Figure 6.16Port Configuration > Operation > USDG Data Mode	69
	Table 6.13: USDG Data Mode	70
	Figure 6.17Port Configuration > Operation > USDG Control Mode	71
	Table 6.14: USDG Control Mode	71
	Figure 6.18Port Configuration > Operation > RFC2217 Mode	71
	Table 6.15: RFC2217 Mode	71
	Figure 6.19Port Configuration > Operation > SSH Console Mode	72
	Table 6.16: SSH Console Mode	72
6.8	Monitor	72
6.8.1	Setting (VCOM 1.0)	72
	Figure 6.20Monitor > Setting	72
	Table 6.17: Setting (VCOM 1.0)	73
6.8.2	Statistic (VCOM 1.0)	73
	Figure 6.21Monitor > Statistic	73
	Table 6.18: Statistic (VCOM 1.0)	73
6.8.3	Connected IP (VCOM 1.0)	74
	Figure 6.22Monitor > Connected IP	74
	Table 6.19: Connected IP (VCOM 1.0)	74
6.8.4	Status (VCOM 2.0)	74
	Figure 6.23Monitor > Status	74
	Table 6.20: Status (VCOM 2.0)	75
6.8.5	VCOM Statistics (VCOM 2.0)	75
	Figure 6.24Monitor > VCOM Statistics	75
6.8.6	VCOM Clients (VCOM 2.0)	75
	Figure 6.25Monitor > VCOM Clients	75
6.8.7	VCOM History (VCOM 2.0)	75
	Figure 6.26Monitor > VCOM History	75
6.8.8	Just-In-Time Diagnostics (VCOM 2.0)	76
	Figure 6.27Monitor > Just-In-Time Diagnostics	76
6.9	Auto Warning (Alarm)	76
6.9.1	Setting	76
	Figure 6.28Alarm > Setting	77
	Table 6.21: Setting	77
6.9.2	Event	78
	Figure 6.29Alarm > Event	78
	Table 6.22: Event	79
6.10	Syslogd	79
6.10.1	Syslogd Setting	79
	Figure 6.30Syslogd > Syslogd Setting	79
	Figure 6.31Syslogd > Syslogd Setting	80
	Table 6.23: Syslogd Setting	80
6.10.2	Syslogd Message	80
	Figure 6.32Syslogd > Syslogd Message	80
6.10.3	VCOM Status	81
	Figure 6.33Syslogd > VCOM Status	81
6.11	Tools	81
6.11.1	Ping	81
	Figure 6.34Tools > Ping	81
	Table 6.24: Ping	81
6.11.2	Certs Generator	82
6.11.3	Reboot	83
	Figure 6.35Tools > Reboot	83

6.12	Management .....	84
6.12.1	Log File .....	84
	Figure 6.36 Management > Log File .....	84
	Table 6.25: Log File .....	84
6.12.2	Change Password .....	84
	Figure 6.37 Management > Change Password .....	84
	Table 6.26: Change Password .....	85
6.12.3	Secure access IP .....	85
	Figure 6.38 Management > Secure access IP .....	85
	Table 6.27: Secure access IP .....	85
6.12.4	Export Device Settings .....	85
6.12.5	Import Device Settings .....	85
	Figure 6.39 Management > Import .....	86
	Table 6.28: Import Device Settings .....	86
6.12.6	Firmware Upgrade .....	86
	Figure 6.40 Management > Firmware Upgrade .....	87

## Chapter 7 Telnet and SSH .....89

7.1	Overview .....	90
7.2	Create a Telnet Connection .....	90
	Figure 7.1 Enable Telnet or SSH Function .....	90
	Figure 7.2 Open the Command Prompt .....	91
	Figure 7.3 Telnet Connection .....	91
7.3	Serial Console .....	92
7.3.1	Connecting the cable .....	92
7.3.2	COM Port Settings .....	92
	Figure 7.4 COM Port Settings .....	92
7.4	Command List .....	93
	Table 7.1: Command List .....	93
7.4.1	System .....	93
7.4.2	Port .....	93
7.4.3	Portadv .....	94
7.4.4	Mvcom .....	94
7.4.5	Mctrl .....	95
7.4.6	Mdata .....	95
7.4.7	Net .....	95
7.4.8	Password .....	96
7.4.9	Alarm .....	96
7.4.10	Monitor .....	96
7.4.11	Time .....	96
7.4.12	Service .....	96
7.4.13	Mrfc2217 .....	96
7.4.14	Apply .....	97
7.4.15	Exit .....	97
7.4.16	Help .....	97
7.4.17	Reboot .....	97

## Chapter 8 TCP and UDP Port .....99

8.1	List of Known TCP and UDP Port Numbers .....	100
	Table 8.1: List of Known TCP and UDP Port Numbers .....	100



# Chapter 1

Introduction

---

## 1.1 Overview

The EKI-1526 Series are network-based serial device servers that connect RS-232/422/485 serial devices, such as PLC, meters, sensors, and barcode readers, directly to a TCP/IP network.

Once connected through a EKI-1526 Series serial server, devices are able to send and receive data through a network. This extends the traditional COM ports of a PC, with access over a TCP/IP network. Through networking, you can control and monitor remote serial devices over either a LAN or WAN. Since the EKI-1526 Series is connected through a TCP/IP network, you may need to know some basic facts about networking in order to connect the server correctly.

The EKI-152x Series features two independent Ethernet ports and MAC addresses to provide a redundant network mechanism to avoid data loss. The EKI-1526 Series provides various operations: COM port redirection mode (Virtual COM Port mode), TCP Server/ Client mode, UDP mode, Control mode and RFC2217 mode. Detailed descriptions of each operation are provided in a later chapter.

## 1.2 Device Features

- 16-port RS-232/422/485 serial communication
- Provides 2 x 10/100 Mbps Ethernet ports for LAN redundancy
- Secure VCOM (Virtual COM), USDG (TCP and UDP) operation modes
- Configuration encryption and image encryption ensures trusted operations.
- Device-level redundancy with Virtual Gateway
- Supports up to 921.6 kbps, and any baud rate setting
- Support SSDP for effortless device discovery
- Provides rich configuration methods: Web Browser, Windows utility, Telnet console and Serial console
- SNMP MIB-II for network management
- Built-in buzzer for easy location
- Standard 1U rack-mount size
- Rear wiring
- Automatic RS-485 direction flow control

## 1.3 Specifications

**Table 1.1: Specifications**

Specifications		Description
Interface	I/O Port	<ul style="list-style-type: none"> <li>■ 2 x RJ-45</li> <li>■ 16 x RS-232/422/485</li> </ul> See Ethernet and Serial Communications in this table for further information.
	Power Connector	Power socket
Physical	Enclosure	SECC chassis
	Installation	Rack
	Dimensions (W x H x D)	438 x 43.6 x 153.9 mm
LED Display	System LED	Power, Status
	Port LED	<ul style="list-style-type: none"> <li>■ LAN: Speed, Link/Active</li> <li>■ Serial: Tx, Rx</li> </ul>
Environment	Operating Temperature	-40 ~ 70°C (-40 ~ 158°F)
	Storage Temperature	-20 ~ 80°C (-4 ~ 176°F)
	Ambient Relative Humidity	95% RH
Ethernet Communications	Compatibility	IEEE 802.3, IEEE 802.3u, IEEE 802.3ab
	Speed	10/100/1000 Mbps, auto MDI/MDIX
	Port Connector	8-pin RJ-45
	Protection	Built-in 1.5 KV magnetic isolation
Serial Communications	Port Type	RS-232/422/485-2w/485-4w, software selectable
	Port Connector	8-pin RJ-45
	Data Bits	5, 6, 7, 8
	Stop Bits	1, 1.5, 2
	Parity	None, Odd, Even, Space, Mark
	Flow Control	XON/XOFF, RTS/CTS
	Baud Rate	<ul style="list-style-type: none"> <li>■ 50 bps ~ 921.6 kbps, any baud rate setting</li> <li>■ 16 ports up to 230.4 kbps simultaneously</li> </ul>
Security	Authentication	RADIUS, LDAP, Local Management
	Security Protocols	SNMPv3, HTTPS (TLS 1.3), SSH
Power	Power Consumption	6.4W
	Power Input	100 ~ 240 VAC, 50 ~ 60 Hz

**Table 1.1: Specifications**

	OS Support for Utility	32-bit/64-bit Windows XP/7/8/8.1/10/11, Windows Server 2016/2019/2022	
	Utility	Advantech EKI Device Configuration Utility	
Software	Operation Modes	<ul style="list-style-type: none"> <li>■ Secure                             <ul style="list-style-type: none"> <li>– COM port redirection mode (Virtual COM)(VCOM 2.0)</li> <li>– TCP server (polling) mode (USDG 2.0)</li> <li>– TCP client (event handling) mode (USDG 2.0)</li> <li>– Pair connection (peer to peer) mode (USDG 2.0)</li> <li>– SSH Console Mode</li> </ul> </li> <li>■ Standard                             <ul style="list-style-type: none"> <li>– COM port redirection mode (Virtual COM)(VCOM 2.0)</li> <li>– TCP/UDP server (polling) mode (USDG 1.0)</li> <li>– TCP/UDP client (event handling) mode (USDG 1.0)</li> <li>– Pair connection (peer to peer) mode (USDG 1.0)</li> <li>– RFC2217 Mode</li> </ul> </li> </ul>	
		Configuration	Web Browser(HTTP/HTTPS), Windows utility, Telnet console, Serial console
		Management	SNMP MIB-II
		Regulatory Approvals	EMC

# Chapter 2

Getting Started

## 2.1 Hardware Overview

### 2.1.1 Front View

The following view shows the EKI-1526N.

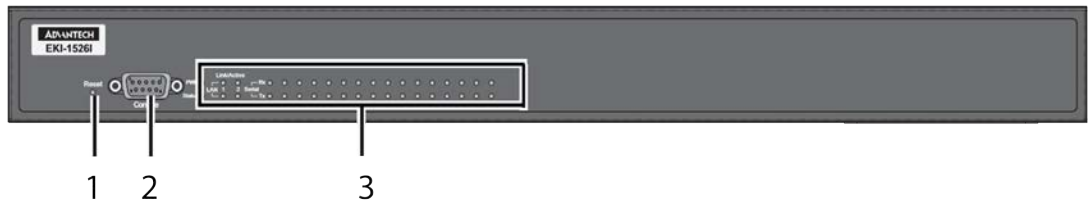

Figure 2.1 Front View

Table 2.1: Front View

No.	Item	Description
1	Reset button	Button allows for system soft reset (3 sec.).
2	Serial port	DB9 pinout, console port (female).
3	System LED panel	See "LED Indicators" on page 8 for further details.

### 2.1.2 Rear View

The following view shows the EKI-1526N.

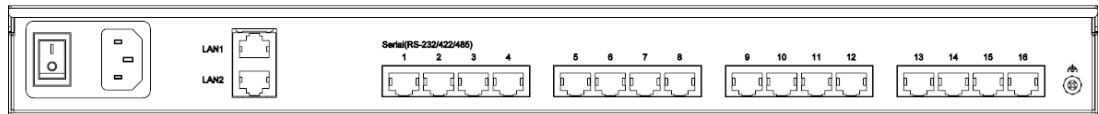

Figure 2.2 Rear View

Table 2.2: Table 2.3: Rear View

No.	Item	Description
1	Power button	Turn the device on and off.
2	AC power in	Supports 100 ~ 240 VAC, 50 ~ 60 Hz.
3	ETH port	2 x RJ-45 ports
4	Serial communication	16 x RJ-45 ports
5	Ground terminal	Screw terminal used to ground chassis.

### 2.1.3 LED Indicators

The following view shows the EKI-1526N.

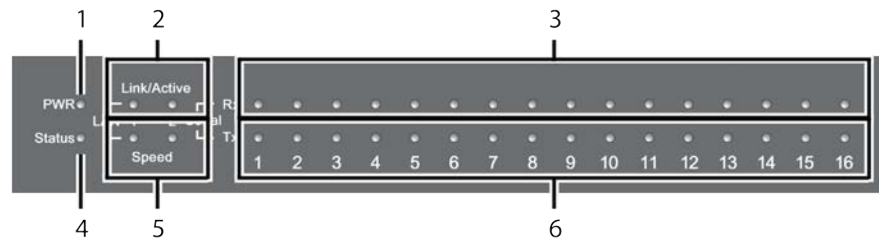

Figure 2.3 System LED Panel

**Table 2.4: LED Indicators**

No.	LED Name	LED Color	Status	Description
1	PWR	GREEN	ON	Power is on
			OFF	Power is off or power error condition exists
2	Link/Active	GREEN	ON	Valid network link
			OFF	Invalid network link
3	RX	GREEN	ON	Data being received
			OFF	No data transmitted
4	Status	GREEN	ON	The device server has been located by utility's location function
			BLINKING	System is ready (1cycle/sec.)
			OFF	System is powered off
5	Speed	GREEN	ON	1000 Mbps speed
		AMBER	ON	100 Mbps speed
			OFF	10 Mbps speed
6	TX	AMBER	ON	Data being transmitted
			OF	No data transmitted

## 2.1.4 Dimensions

The following view shows the EKI-1526N.

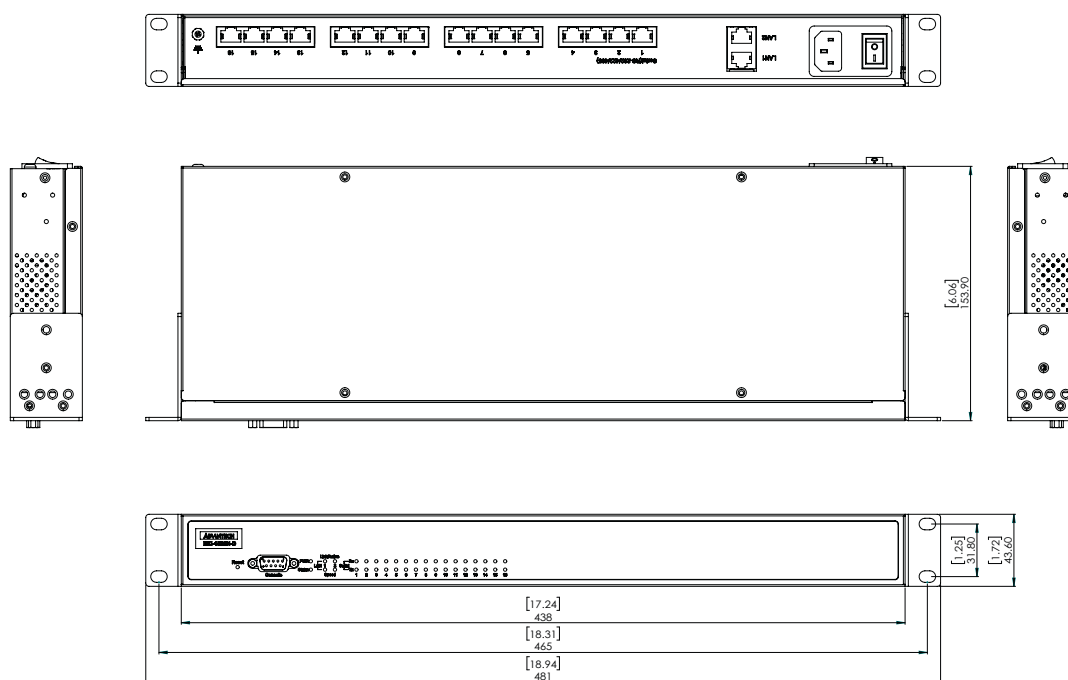

**Figure 2.4 EKI-1526N Dimensions**

## 2.2 Connecting Hardware

**Caution!** *Devices in use may become hot to the touch. To prevent damage or injury, allow the device time to cool down before attempting to service it.*



### 2.2.1 Rack Mount

1. Align the rack mount brackets with the holes on the Serial Device Server.
2. Secure the rack mount brackets with screws.

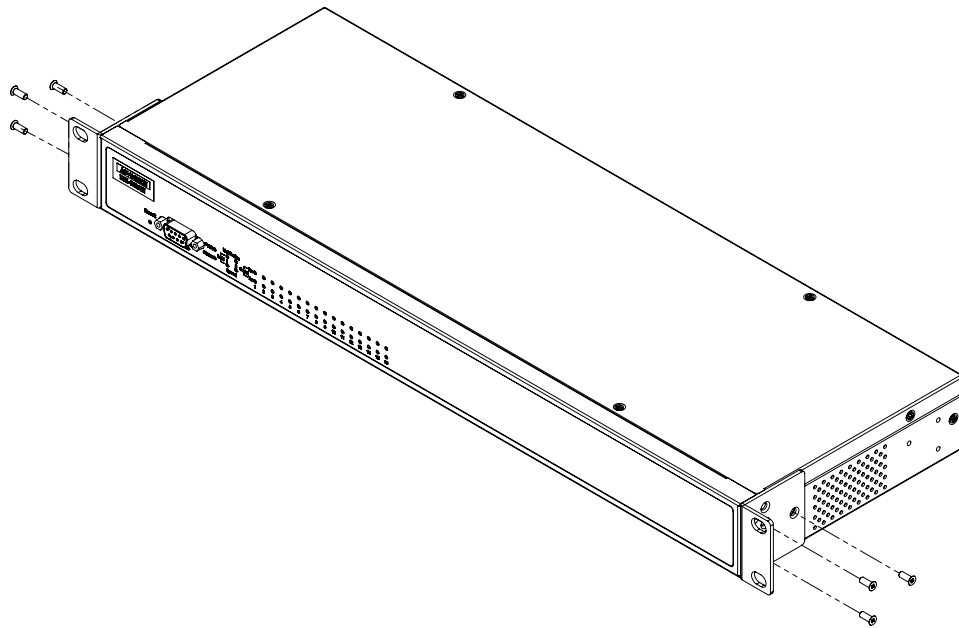

**Figure 2.5** Installing the Rack Mount Brackets

3. Align the Serial Device Server with the posts on the rack cabinet.
4. Secure the Serial Device Server with screws.

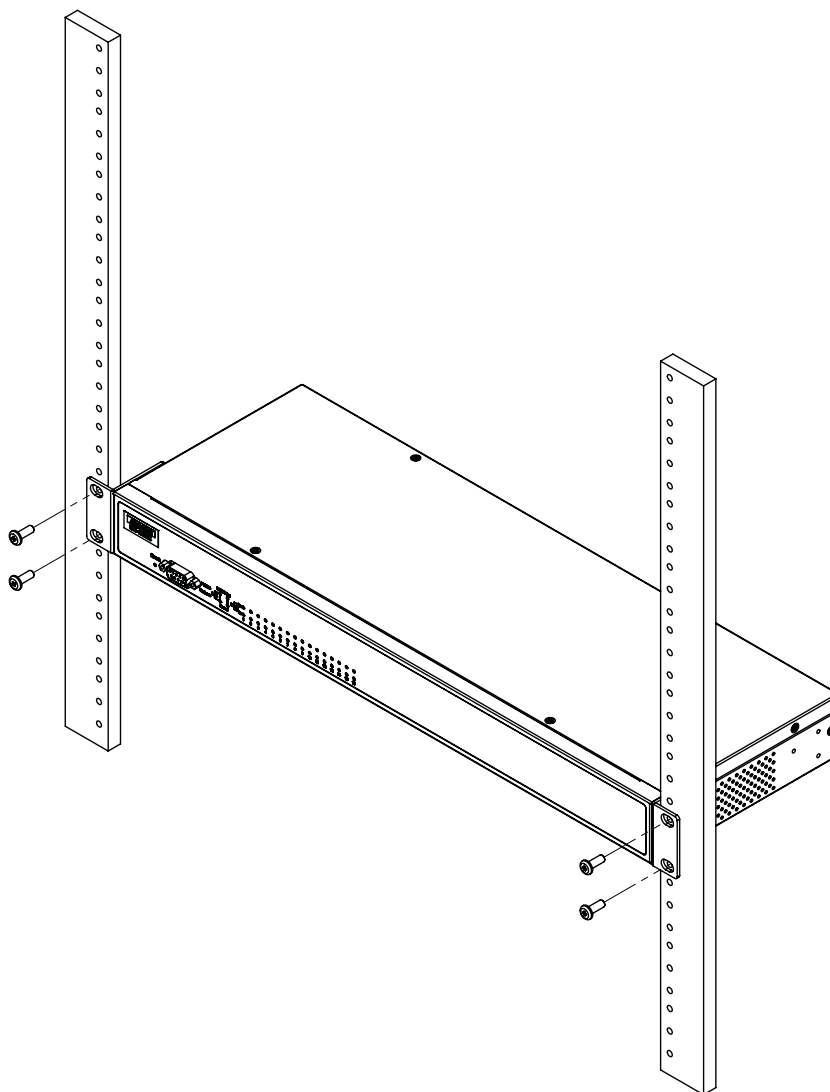

**Figure 2.6 Installing the Serial Device Server**

## 2.2.2 Serial Connection

the EKI-1526N provides 16 RJ-45 connectors. The RS-232/422/485 pin assignments are shown below.

**Table 2.5: EKI-1526N Serial Port Pin Assignments**

Pin	1	2	3	4	5	6	7	8	9
RS-232	DCD	RX	TX	DTR	GND	DSR	RTS	CTS	-
RS-422	TX-	TX+	RX+	RX-	GND				
RS-485	DATA-	DATA+			GND				

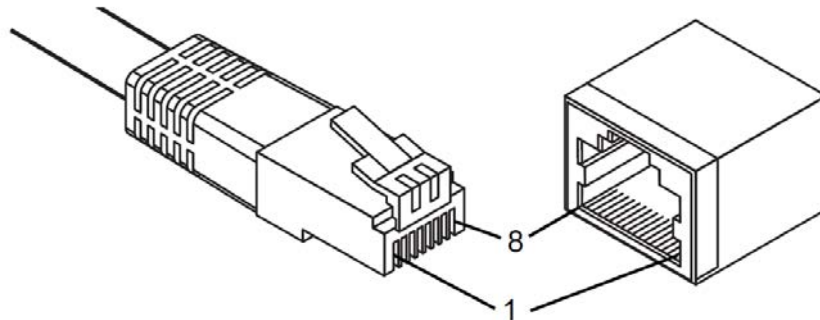

**Figure 2.7 RJ45 Plug & RJ45 Connector Pin Assignment**

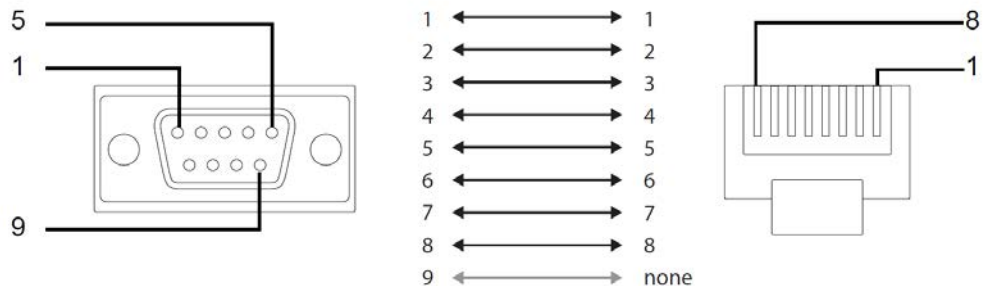

**Figure 2.8 RJ45 to DB9 Cable Assignment**

The optional accessory OPT1J-AE for EKI-1526N is an RJ-45 to DB9 (male) cable. Connect the serial data cable between the EKI-1526N and the serial devices.



**Figure 2.9 RJ45 to DB9 (Male) Cable**

## 2.2.3 Power Connection

**Warning!** *Power down and disconnect the power cord before servicing or wiring the serial device server.*



**Warning!** *Do not disconnect modules or cabling unless the power is first switched off.*



*The device only supports the voltage outlined in the type plate. Do not use any other power components except those specifically designated for the serial device server.*

**Warning!** *Disconnect the power cord before installation or cable wiring.*



**Warning!** *Risk of explosion if the battery is removed and/or replaced by an incorrect type.*



**Warning!** *Risk of defeating the safeguard if the battery is removed or replaced by an incorrect type.*



**Warning!** *Risk of explosion if the battery is disposed in fire or hot environment or mechanically damaged--denting, crushing, and piercing the cell case.*



**Warning!** *Risk of explosion or leakage of flammable liquid or gas if the battery is left in an extremely high temperature environment.*



**Warning!** *Dispose of used batteries in accordance with your local environmental regulations*



**Caution!** *Electrical current from power, telephone, and communication cables is hazardous.*



*To avoid a shock hazard:*

- *Do not connect or disconnect any cables or perform installation, maintenance, or reconfiguration of this product during an electrical storm.*
- *Connect all power cords to a properly wired and grounded power source.*
- *Connect to properly wired power sources any equipment that will be attached to this product.*
- *When possible, use one hand only to connect or disconnect signal cables.*
- *Never turn on any equipment when there is evidence of fire, water, or structural damage.*
- *Disconnect the attached AC power cords, DC power sources, network connections, telecommunications systems, and serial cables before you open the device covers, unless you are instructed otherwise in the installation and configuration procedures.*
- *Connect and disconnect cables as described in the following table when you install, move, or open covers on this product or attached devices.*

The following is only available for EKI-1526N AC power line with its AC connector. If the power is properly supplied, you can turn on the power switch and the PWR LED will light green.

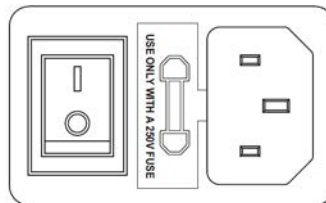

**Figure 2.10 Connecting AC Power**

# Chapter 3

## Utility Configuration

## 3.1 Configuration Utility Overview

Advantech EKI series serial device servers provide an easy-to-use utility to configure your serial device server through an Ethernet connection. For secure administration, it can also restrict the access rights for configuration to only one host PC. With this secure function enabled, other PCs will not have permission for configuration. After the installation program on the Advantech EKI Device Configuration Utility is finished, the serial device servers are ready for use and configuration.

Advantech EKI Device Configuration Utility is an excellent device server management tool. You can connect and configure the local and remote Advantech serial device servers easily. The utility provides access to the following functions:

- Configure the network settings (you can set the IP address, Gateway address, and Subnet mask).
- View and set the serial port parameters (configure operating mode, baud rate, serial port settings and operating mode settings).
- Perform diagnostic tests (virtual COM port testing, port status list).
- Perform administrative functions (export and import the serial device server setting, manage access IP, a descriptive name, upgrade firmware).

**Note!** *The EKI-1526 can be configured via the Web Interface or the EKI Utility running on a PC. The Web Interface is the primary setup tool, offering both basic and advanced configuration features. For Web Interface configuration, please refer to Chapter 6.*



## 3.2 Installing the Configuration Utility

The Advantech EKI Device Configuration Utility is available for download. Please download the latest version from Advantech's website at <http://www.advantech.com>.

**Note!** *This application requires Microsoft .NET Framework version 4.0 or later.*



*Windows 10 (post-2019) and Windows 11 already include .NET 4.8 by default, so no additional installation is normally required.*

### 3.2.1 Installing the Software

1. Please download the Advantech EKI Device Configuration Utility from the Advantech website at <http://www.advantech.com>. and then run the following setup program to begin the installation process: EKI\_Device\_Configuration\_Utility\_[version].exe
2. If there is an existing COM port mapping utility on the host PC, remove it at this time. A system reboot may be necessary before continuing the installation.
3. Once the InstallShield Wizard screen displays, click Next to proceed with the installation.

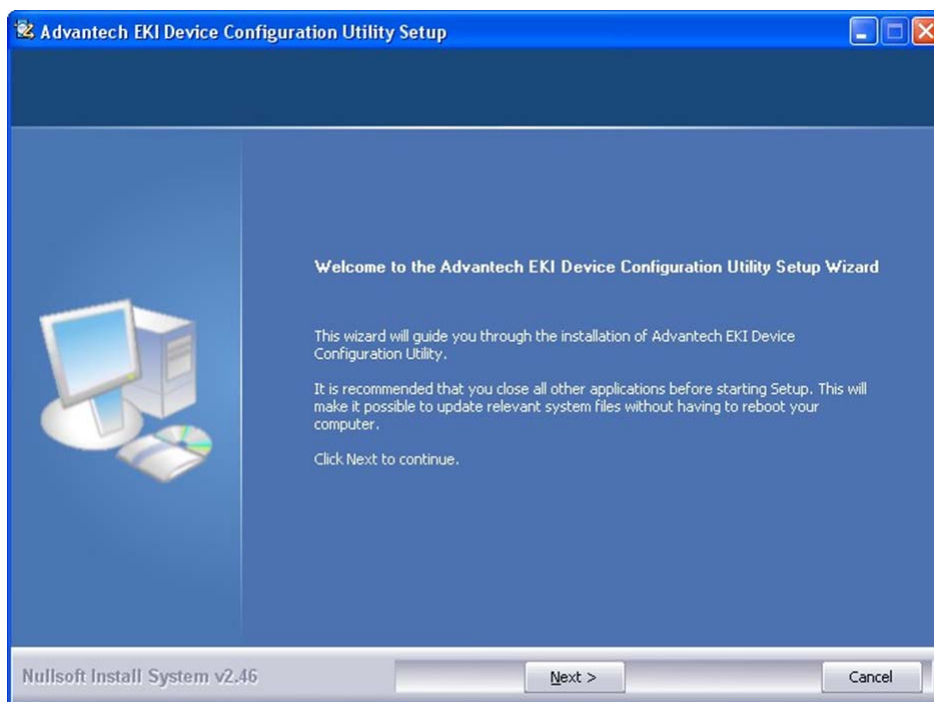

**Figure 3.1 InstallShield Wizard 1 of 4**

4. The Software License Agreement displays, press I Agree to continue or Cancel to stop the installation.

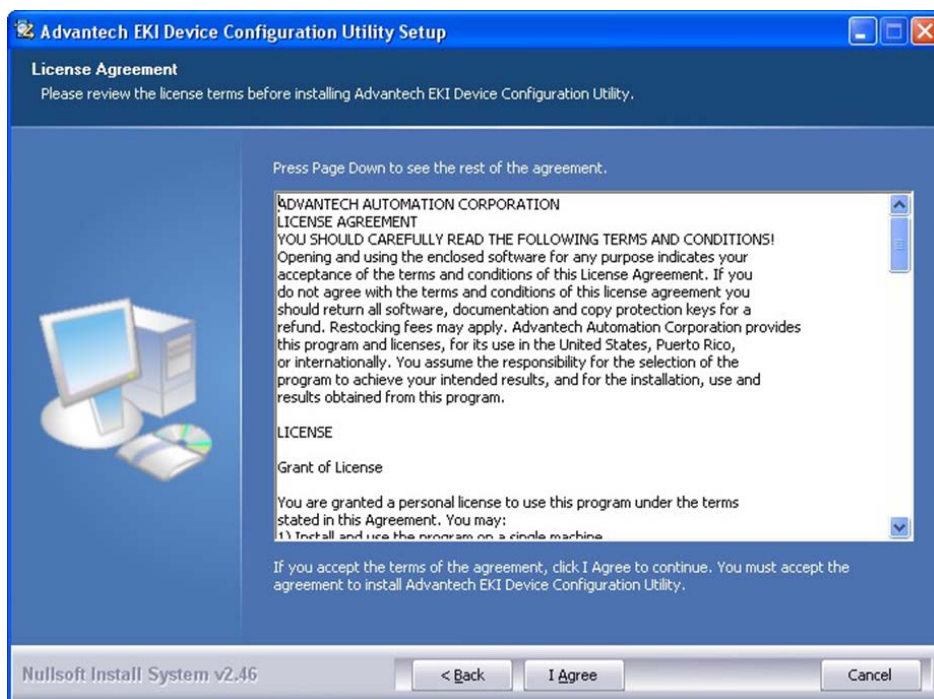

**Figure 3.2 InstallShield Wizard 2 of 4**

The InstallShield continues and a status screen display. The default installation path is C:\Program Files\EKI Device Configuration Utility.

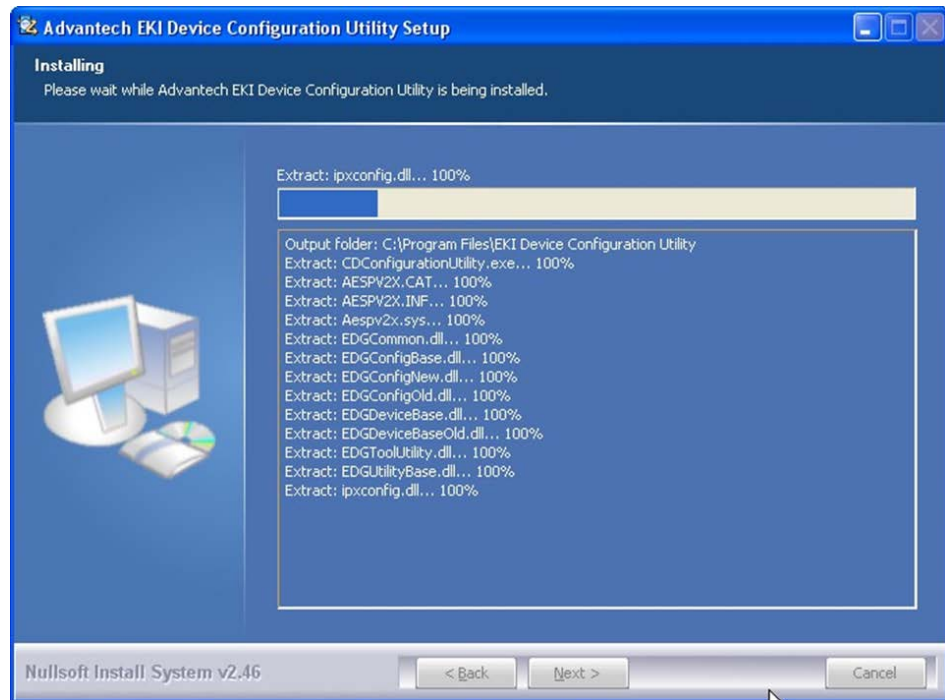

**Figure 3.3 InstallShield Wizard 3 of 4**

5. Once the installation of the package is finished a Configuration Utility Setup screen display. Click Finish to conclude the process and exit the InstallShield Wizard.

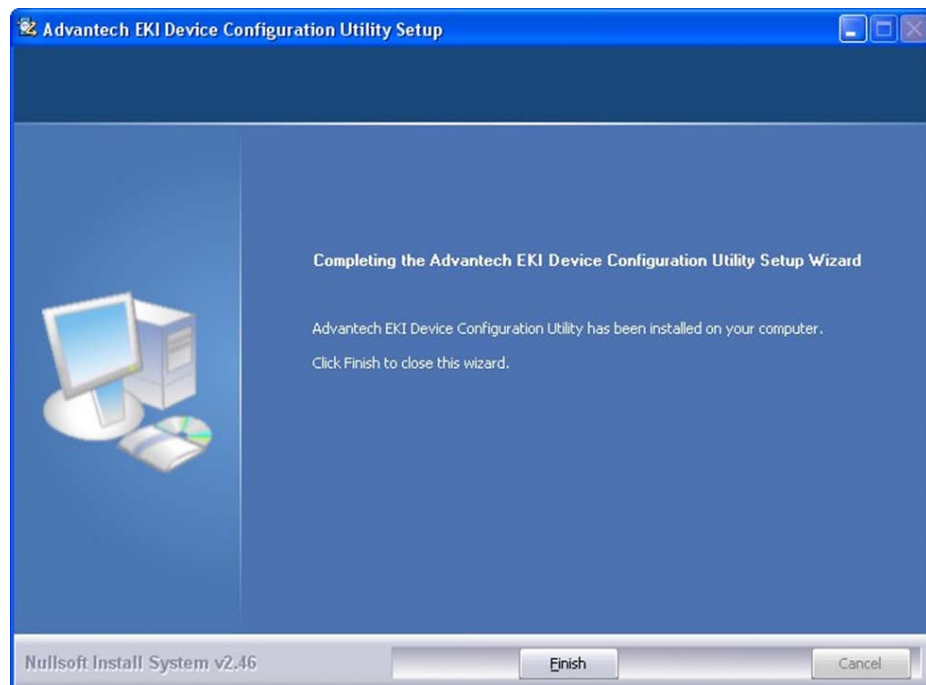

**Figure 3.4 InstallShield Wizard 4 of 4**

### 3.3 Menu Bar

You can open the Configuration Utility from the Windows Start Menu by clicking Start > All Programs > EKI Device Configuration Utility > EKI Device Configuration Utility. The Configuration Utility displays as shown in the following figure.

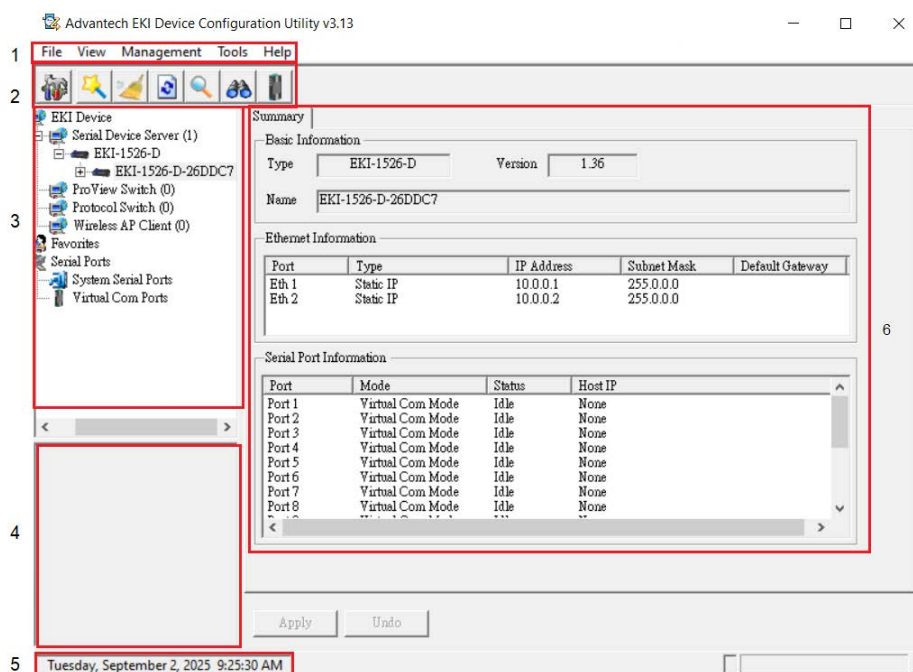

**Figure 3.5 Configuration Utility Overview**

**Table 3.1: Configuration Utility Overview**

No	Item	Description
1	Menu Bar	Displays File, View, Management, Tools and Help.
2	Quick Tool Bar	Useful management functions shortcuts.
3	Serial Device Server List Area	Available devices are listed in this area. Devices and COM ports can be organized or grouped in this area.
4	Information Panel	Click on the devices or move cursor to the devices, the related information is shown in this area.
5	Status Bar	Displays the current time.
6	Configuration Area	Click on the item on the Device Server List Area, the configuration page displays.

## 3.4 Quick Tool Bar

The Advantech EKI Device Configuration Utility makes use of a Quick Tool Bar menu to allow quick access to the management functions. See the following figure for further information.

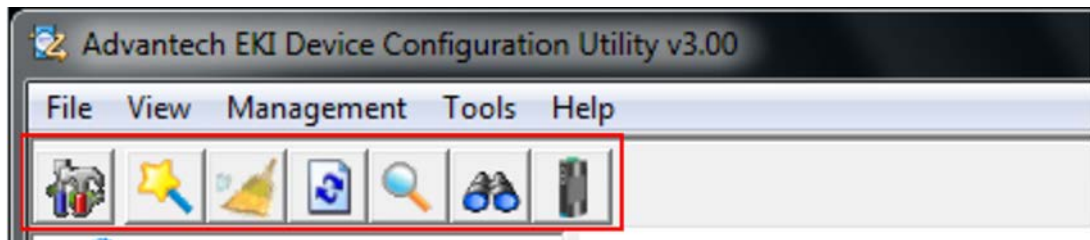









Figure 3.6 Quick Tool Bar Overview

Table 3.2: Quick Tool Bar Overview

Icon	Item	Description
	Utility Settings Clear	Configure the general settings for the Main Form Setting and Device Manager menus. Refer to "Utility Settings" on page 40.
	Configuration Wizard	Start the software wizard (setup assistant) to lead you through the VCOM configuration process for device server product.
	Clear Device List and Search Again	Click to clear listed device servers in the Serial Device Server List Area and initiate a new search. NOTE: A continuous click of the icon results in the following message: Please do not refresh so frequently.
	Search Again	Click to search for serial device servers on the local LAN.
	Add IP Address to Favorite	Click to include the selected IP Address into the Favorites list group.
	Search for a Range of IP Addresses	Click to begin a range search. Enter the beginning and ending IP addressed to being a search within the string parameters.
	Manual Direct Mapping Virtual COM Port	Click to add a target by selecting the Device Type and inputting the IP address without physically connecting the serial device server to the network.

## 3.5 Utility Settings

### 3.5.1 Utility Settings

#### 3.5.1.1 Main Form Setting

Click **View > Settings** to configure utility settings.

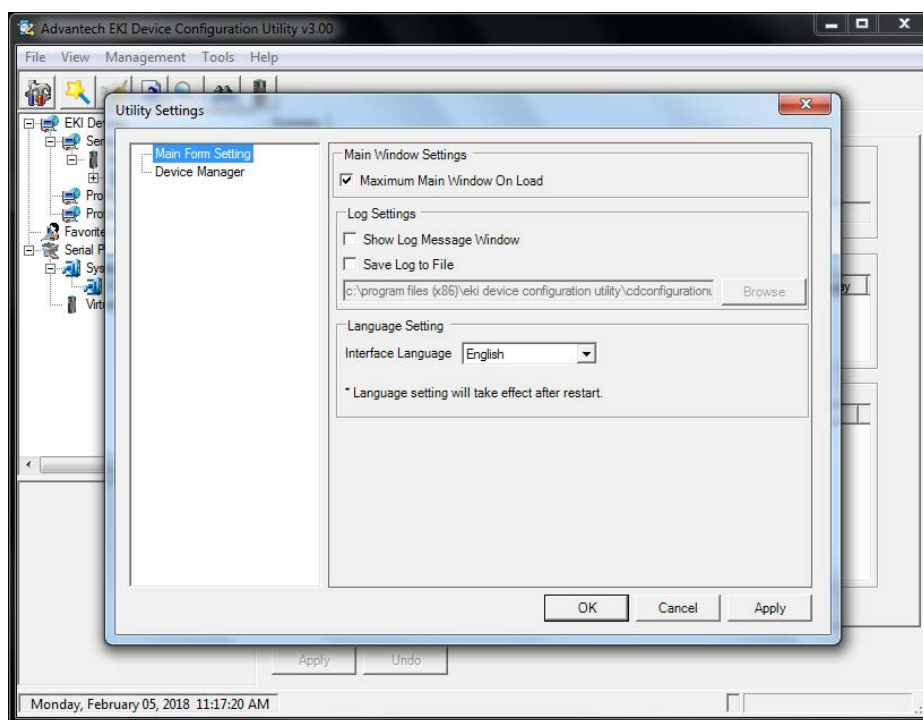
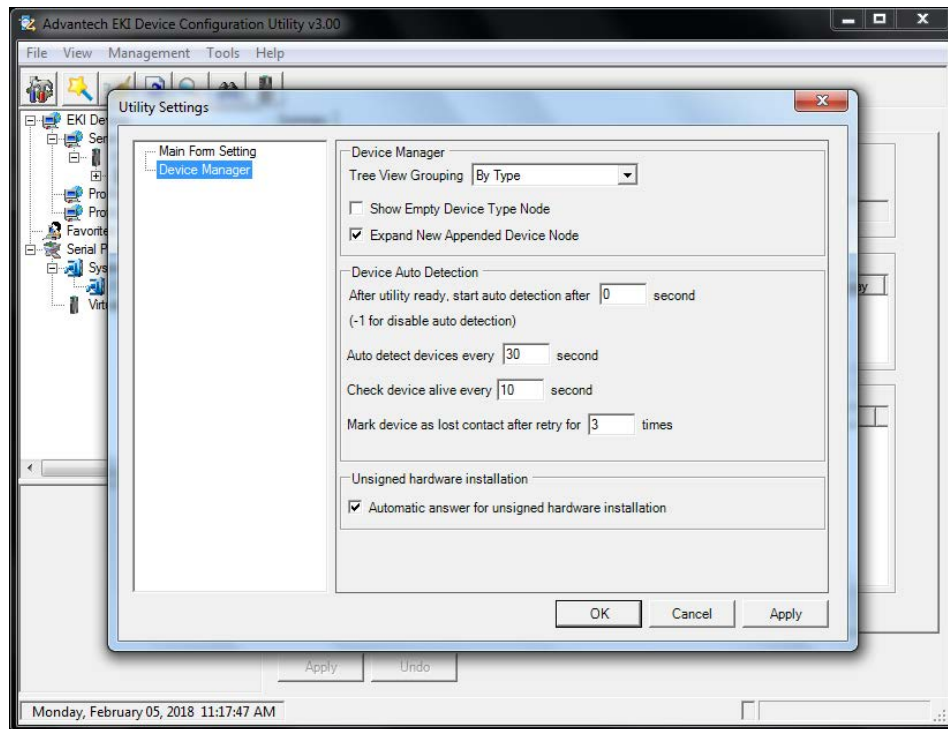

**Figure 3.7 View > Settings > Main Form Setting**

**Table 3.3: Main Form Setting**

Item	Description
<b>Main Window Settings</b>	
Maximum Main Window On Load	Check the box to enable the limiting of main windows on-load to the maximum value.
<b>Log Settings</b>	
Show Log Message Window	Check the check box to activate the AdvLogMessage form. The Form Log message displays.
Save Log to File	Check the check box to save log to file.
Browse	If the Save Log to File option is enabled, click Browse to select a file to save log data.
<b>Language Settings</b>	
Interface Language	Click the drop-down menu to select an interface language: Traditional Chinese, Simplified Chinese or English. NOTE: A restart is required for the settings to take effect.
OK	Click <b>OK</b> to save and exit the Utility Settings menu.
Cancel	Click <b>Cancel</b> to discard the changes.
Apply	Click <b>Apply</b> to save the main form settings.

### 3.5.1.2 Device Manager



**Figure 3.8 View > Settings > Device Manager**

**Table 3.4: Device Manager**

Item	Description
Device Manager	
Tree View Grouping	Click the drop-down menu to enable or disable grouping.
Show Empty Device Type Node	Check the check box to show empty device type node or not.
Expand New Appended Device Node	Check the check box to expand a new appended device node.
Device Auto Detection	
Auto detect devices every X second	Enter a value to specify the time to auto detect devices.
Check device alive every X second	Enter a value to specify the time to check device alive
Mark device as lost contact after retry for X times	Enter a value to specify the time to mark device as lost contact.
Unsigned Hardware Installation	
Automatic answer for unsigned hardware installation	Check the check box to enable or disable answer automatically for unsigned hardware installation
OK	Click <b>OK</b> to save and exit the utility setting.
Cancel	Click <b>Cancel</b> to discard the changes.
Apply	Click <b>Apply</b> to save the utility setting.

## 3.5.2 Discovering Your Device Server

**Note!** *The EKI-152x supports SSDP (Simple Service Discovery Protocol). After enabling the SSDP function on the EKI-152x configuration web-page, users can use Windows Network Discovery to easily discover the EKI-152x.*

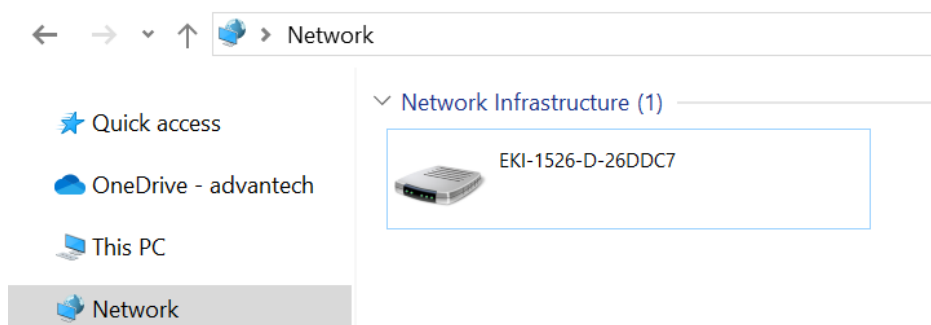

Figure 3.9 Network

### 3.5.2.1 Auto Searching

Advantech Serial Device Server Configuration Utility will automatically search all the EKI-1526 Series device servers on the network and show them on the Serial Device Server List Area of the utility. The utility provides an auto-search function to show your device (s) by simply executing the configuration utility program from the Start Menu.

From here all device on the same network domain will be searched and displayed on Device Server List Area. You can click on the device name to show the features of the specific device.

Click on the “+” before the model name, and the utility will expand the tree structure to show the individual device name. Click on the “-” minus symbol before the model name, and the utility will collapse the tree structure.

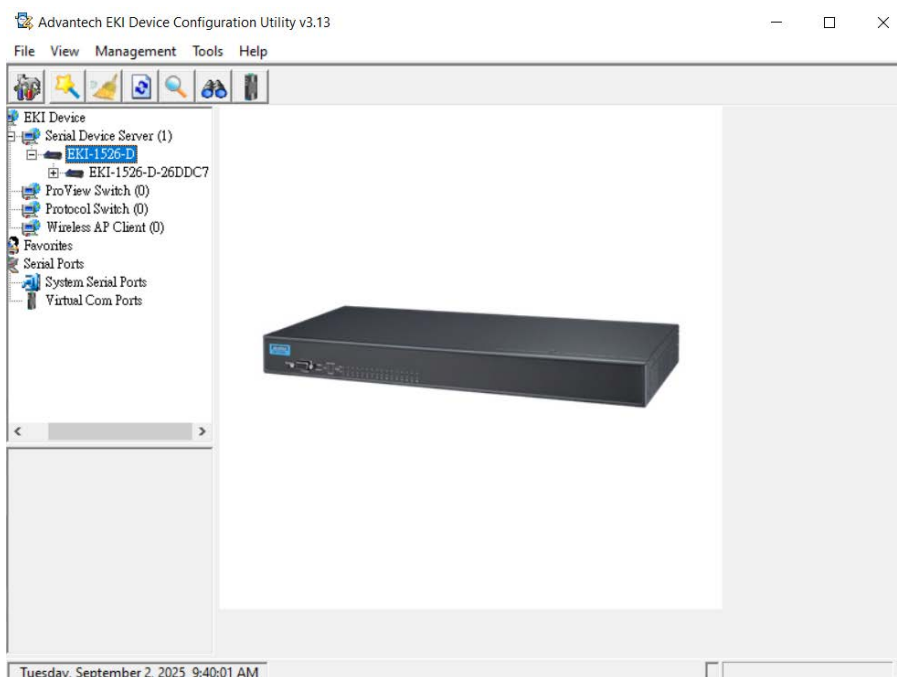

Figure 3.10 Open View of Serial Device Configuration Utility

In the previous figure, the EKI-1526 Series device server is listed as EKI-1526-D-26DDC7.

**Note!** *When you run the configuration utility for the first time, the default device name is obtained from the serial device's MAC identification number. The name can be altered through the configuration utility.*

Select the device in this sub-tree. The first tab on the Configuration Area shows the summary of “Basic Information” included device type, version, and name, “Ethernet Information”, and “Serial Port Information”. The serial port information frame displays the operation mode, status and connected host IP.

Click on the “+” before the device name, and the utility will expand the interfaces on this device server.

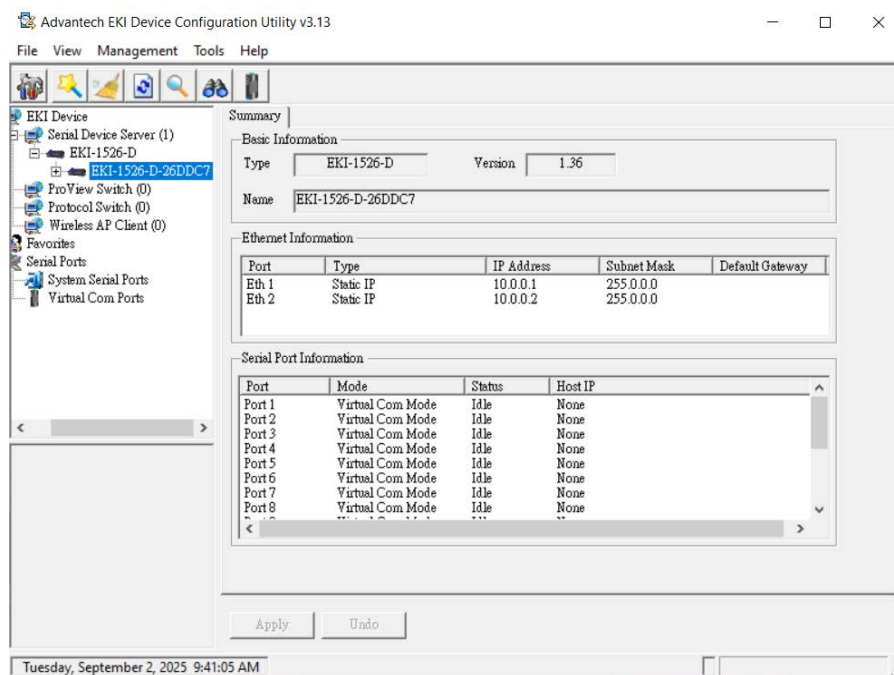

**Figure 3.11 Selecting a Device**

Click on each item to enter the configuration page to change the setting. The configuration will be introduced on following sections.

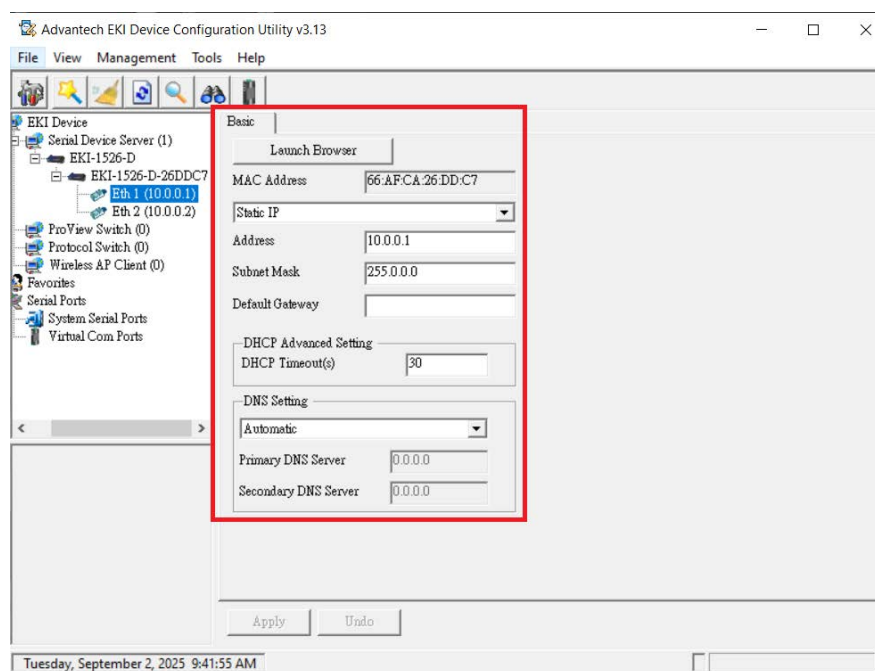

Figure 3.12 Viewing Basic Settings

### 3.5.3 Network Settings

Prior to setting up the server's IP address determine the IP address mode.

There are four mode types available:

- Static IP: mode to assign a specific assigned address
- DHCP / AutoIP: mode to automatically assign IP addresses through a DHCP server
- BOOTP / AutoIP: mode to automatically assign an IP address through the configuration server
- DHCP/BOOTP/AutoIP: mode to automatically assign an IP address using a Bootstrap Protocol or DHCP server.

The server is set with the following default IP configuration:

- 10.0.0.1 (Eth1)
- 10.0.0.2 (Eth2)

The EKI-1526 Series includes a software utility option, which you can install on your system, for configuration through computer-based software. The EKI-1526 Series also includes a web interface option for configuration through a standard web browser.

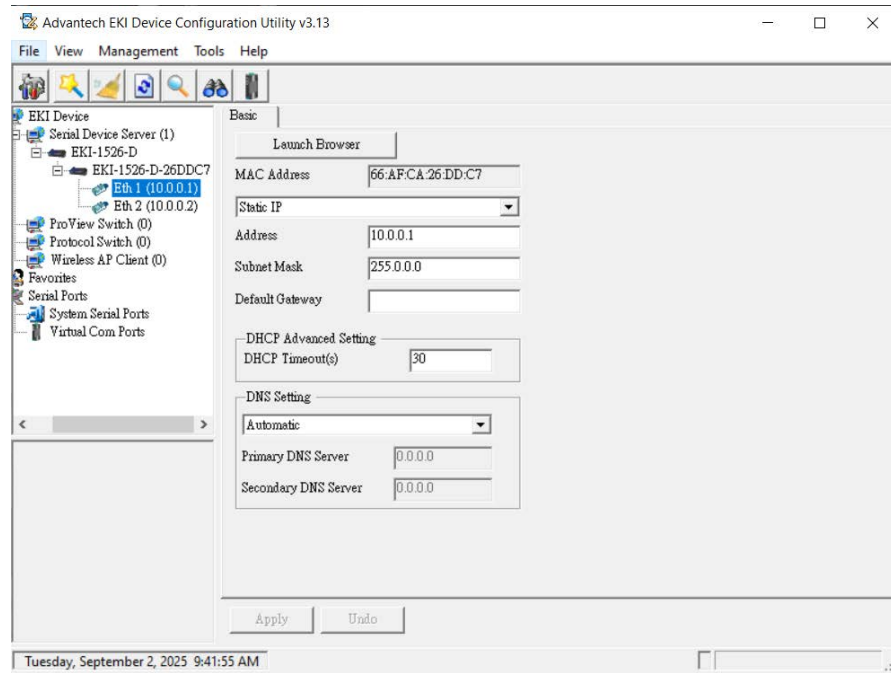

**Figure 3.13 Utility Overview**

You can choose from four possible IP Configuration modes --- Static, DHCP, BOOTP, and DHCP/BOOTP.

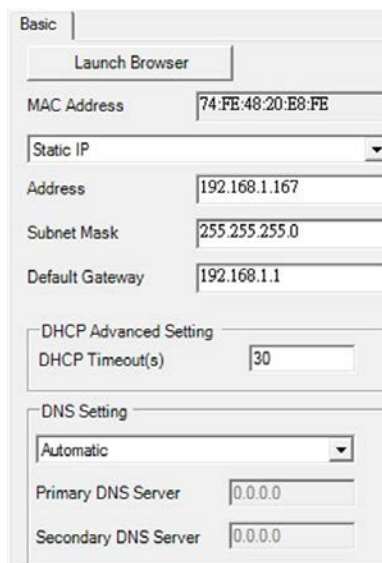

**Figure 3.14 Network Settings Overview**

**Table 3.5: Network Settings**

Item	Description
Static IP	Static IP User defined IP address, Subnet Mask, and Default Gateway.
DHCP + Auto-IP	DHCP Server assigned IP address, Subnet Mask, Default Gateway, and DNS.
BOOTP + Auto-IP	BOOTP Server assigned IP address.
DHCP + BOOTP + Auto-IP	DHCP Server assigned IP address, Subnet Mask, Default Gateway, and DNS, or BOOTP Server assigned IP address. (If the DHCP Server does not respond)
DNS Setting	In order to use DNS feature, you need to set the IP address of the DNS server to be able to access the host with the domain name. The EKI-1526 Series device server provides Primary DNS Server and Secondary DNS Server configuration items to set the IP address of the DNS server. Secondary DNS Server is included for use when Primary DNS server is unavailable.
DHCP Advanced Setting	When you enabling DHCP protocol to get IP address, it will be waited DHCP server to give IP within DHCP time out. The default value is 180 seconds.

**Note!** *When you have finished the configuration of these settings for each category, please press the “Apply” button in order to make these settings effective on the Serial Device Server.*



## 3.6 Administrator Settings

### 3.6.1 Locate the Serial Device Server

When several serial device servers are connected to the network, identification of a specific serial device is possible through the Locate function.

To locate the serial device server:

1. From the device list frame, locate the desired device and right-click on it to display the settings menu.
2. Select **Locate** from the menu.

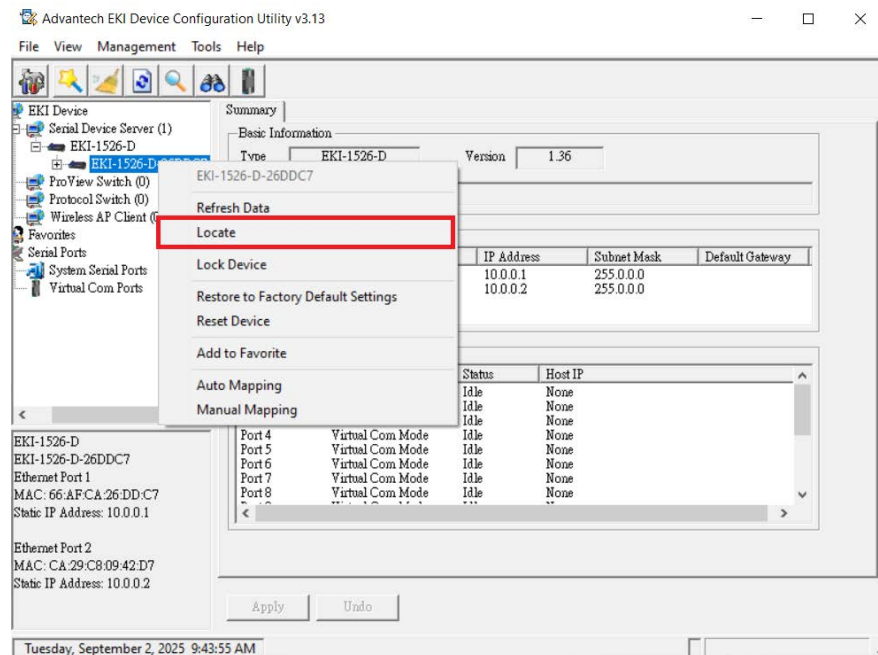

Figure 3.15 Locate the Serial Device Server

The unit's Status LED will turn solid amber and the buzzer will sound until you click **Stop Locate**.

### 3.6.2 Securing the Serial Device Server

#### 3.6.2.1 Lock the Serial Device Server

The configuration utility provides the "Lock Device" function to make it more secure.

To lock the serial device server:

1. Right-click a desired device to display the settings menu.
2. Select **Lock Device**.

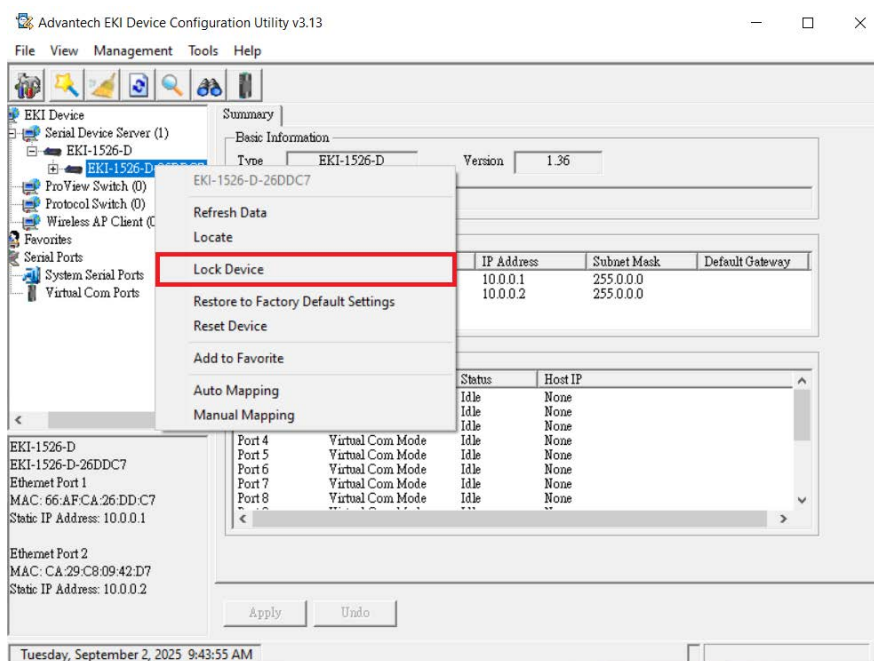

**Figure 3.16 Lock the Serial Device Server**

3. Enter a password. Retype the password entry to confirm the profile password.

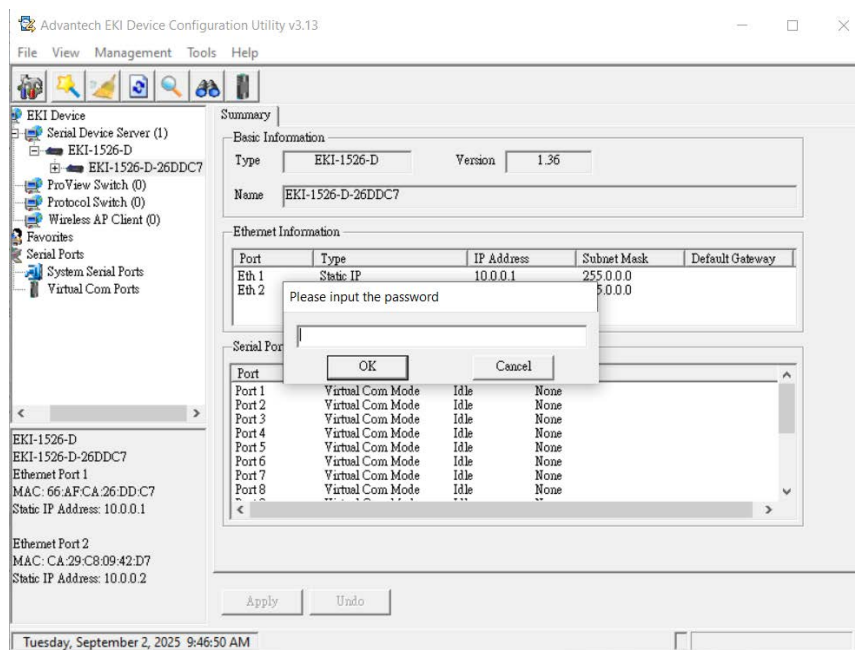

**Figure 3.17 Enter a Password**

4. Right-click a desired device to display the settings menu. Select Reset Device to restart the serial device server and store your setting password into the memory.

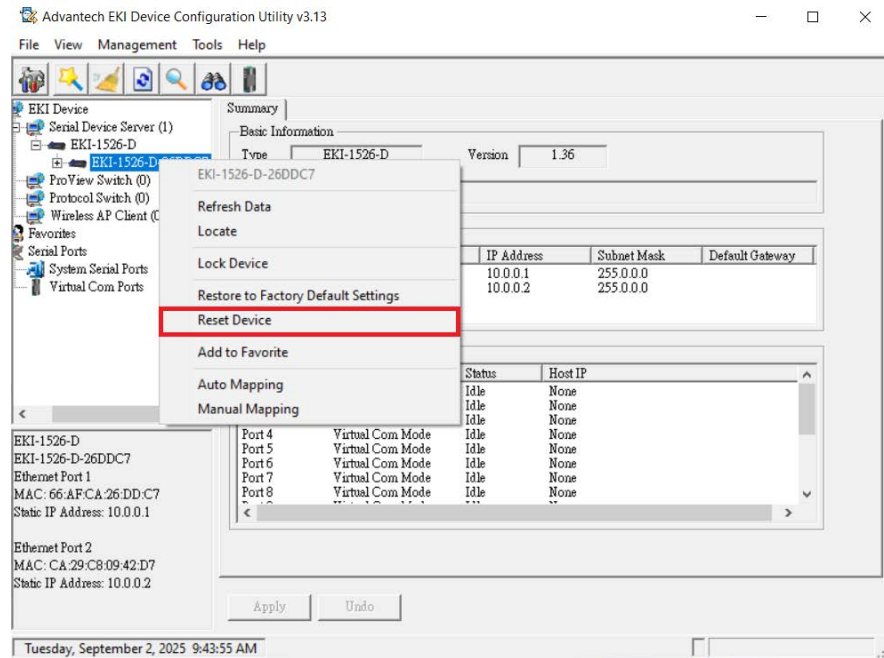
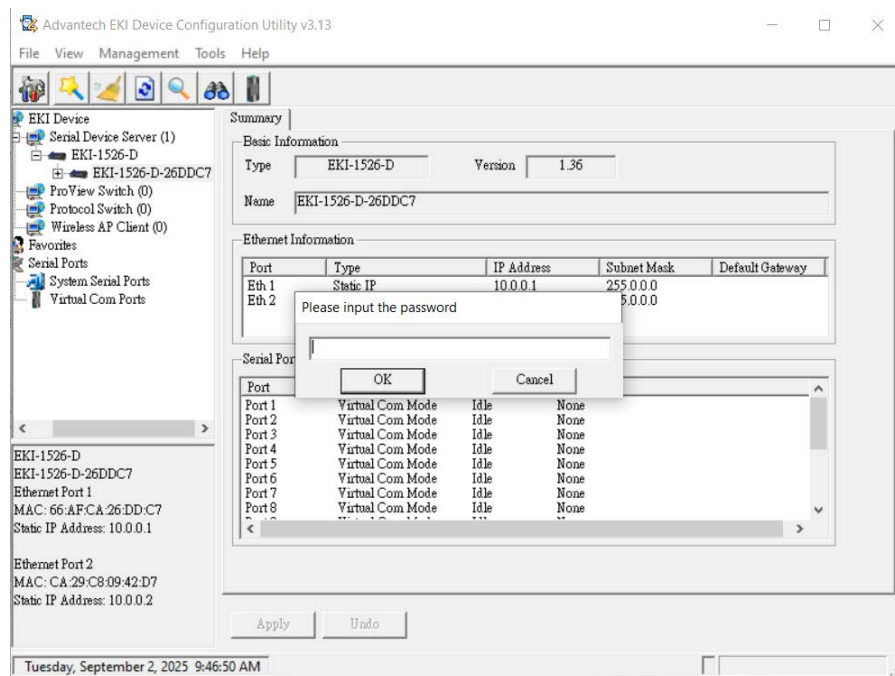

**Figure 3.18 Reset Device**

### 3.6.2.2 Unlock the Serial Device Server

To unlock the serial device server:

1. Right-click a desired device to display the settings menu.
2. Select Unlock Device.
3. Enter the password as entered in the Lock Device procedure.



**Figure 3.19 Unlock the Serial Device Server**

If you forgot the password, you must restore the setting of the serial device server to the factory defaults, which will be introduced in the next section.

### 3.6.3 Restore to Factory Default Settings

The configuration utility provides the function to restore the serial device server to factory default settings.

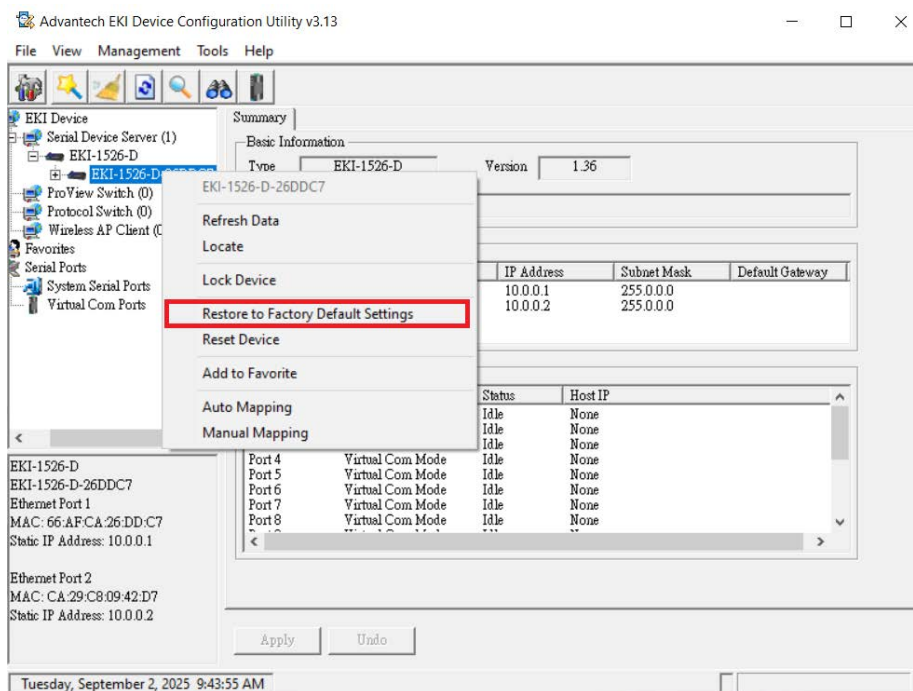

Figure 3.20 Restore to Factory Default Settings

The confirm message will display after clicking Restore to Factory Default Settings. If you really want to restore the serial device server to factory default settings, please click Yes button to continue.

Power off the serial device server within ten seconds. After reconnecting the power, all settings will be reset to the factory default. If the power supply remains connected for more than ten seconds, the serial device server will not be changed.

### 3.6.4 Resetting the Device

The **Reset Device** is available to allow you to reset the serial device server. The function disconnects both the Ethernet and serial connections.

The function also allows the serial device server to save new configuration settings to flash memory. Once a new setting is changed, you can use the Save function to accept the changes. You will need to reset the device to save the settings to flash memory.

To reset the device:

1. Right-click a desired device to display the settings menu.
2. Select **Reset Device**.

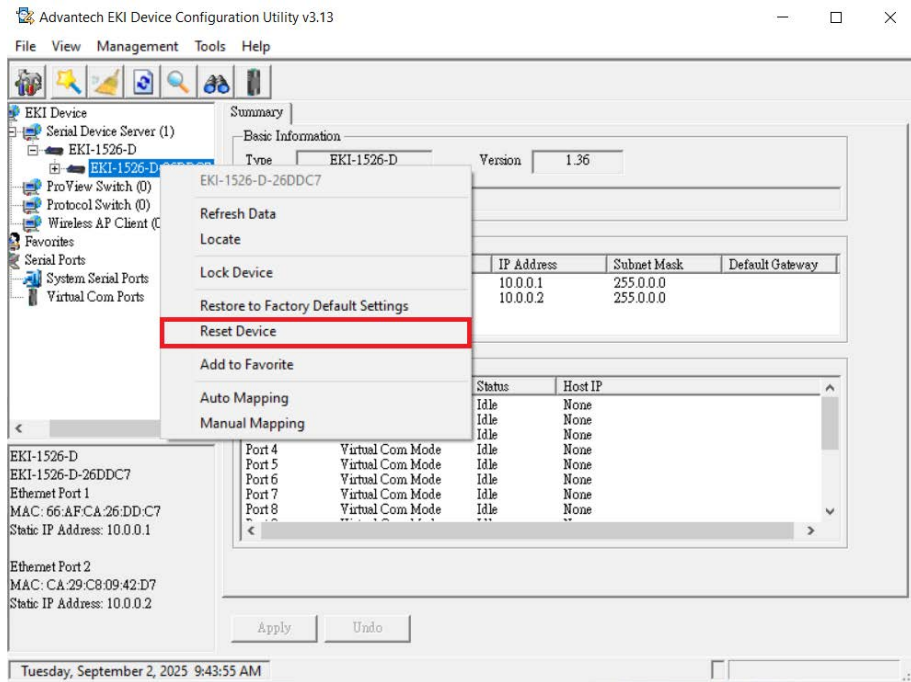
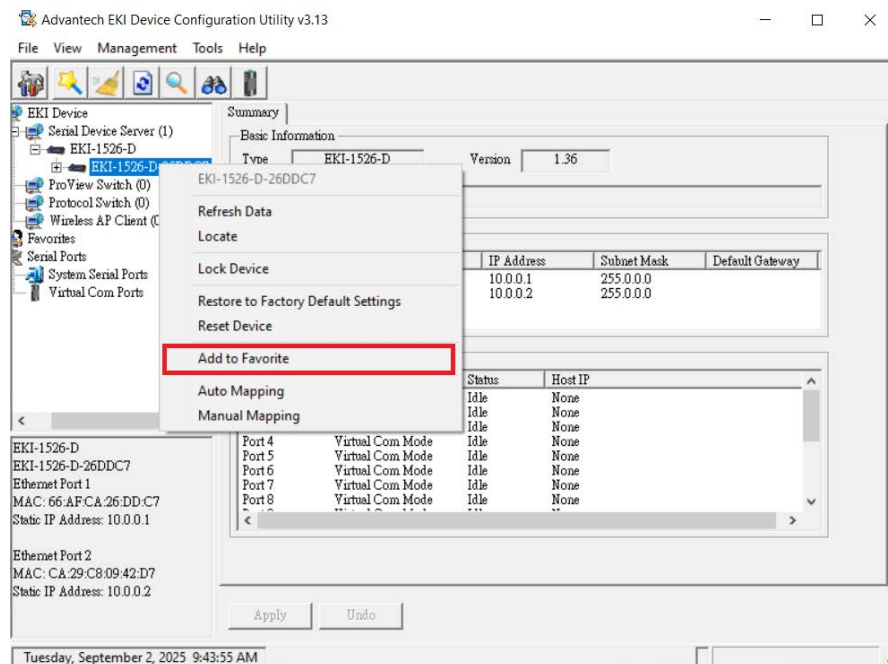

**Figure 3.21 Reset Device**

The device resets. Once the process is complete, the serial device server displays under the Serial Device Server listing once again.

### 3.6.5 Add to Favorite

The Add to Favorite function allows to easily map available devices to Favorite's. By bookmarking specific devices, you can create quickly accessible shortcuts for existing critical devices from the vast pool of locally or remotely networked EKI-1526 Series devices.



**Figure 3.22 Add to Favorite**

### 3.6.6 Auto Mapping

See “Auto Mapping” on page 44 for further details.

### 3.6.7 Manual Mapping

See “Manual Mapping” on page 46 for further details.

## 3.7 Create CA

Generate the Certificates by EKI Utility on Windows

### 1. Check System Settings

Right-click This PC and select Properties. This will open the System page in the Control Panel. Alternative methods may also be used.

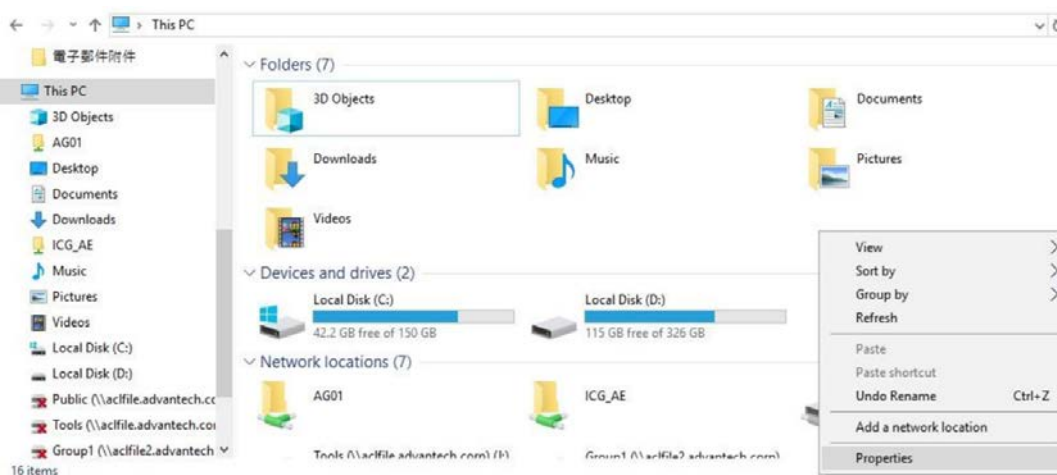

### 2. Advanced System Settings

In the System page, click Advanced System Settings. Navigate to the Advanced tab and click Environment Variables.

### 3. Modify Environment Variables

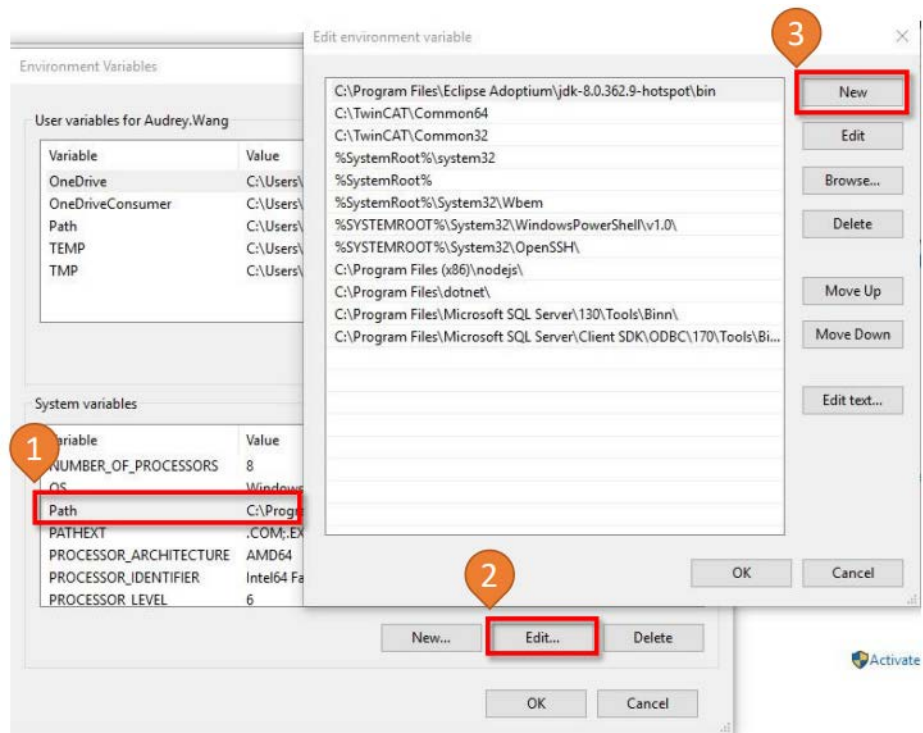

#### 4. Generate Certificates Using EKI Utility

After adding the environment variable, open **EKI Utility** and go to **Tools > Create CA**.

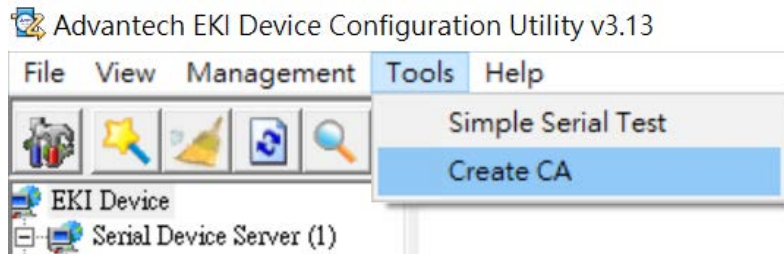

The screenshot shows a configuration dialog box with four main sections: TLS Version, RootCA, Server, and Client. Each section has a checked checkbox and a text input field. The RootCA section also includes two buttons: 'Select PEM' and 'Select KEY'. At the bottom are 'OK' and 'Cancel' buttons.

Section	Option	Value
TLS Version	<input checked="" type="checkbox"/> TLS v1.3	
RootCA	<input checked="" type="checkbox"/> Create new RootCA	
Server	<input checked="" type="checkbox"/> Create new Server Cert.	server_tls13
	Name	server_tls13
Client	<input checked="" type="checkbox"/> Create new Client Cert.	client_tls13
	Name	client_tls13

Select the folder to store the generated certificate files. Select a folder to store the generated certificate files.



# Chapter 4

Selecting An  
Operating Mode

## 4.1 Overview

The EKI-1526 Series is designed to network-enable any RS-232/422/485 serial device, and provides industry-grade hardware and easy-to-use software to make connecting serial devices to an Ethernet network a surprisingly simple process.

These units immediately upgrade your existing serial devices for integration into the Internet world. The EKI-1526 Series features many powerful functions, such as high-speed data transfer, access-control, auto-detection of all EKI-1526 Series products, and more.

After the simple installation steps to attach your network and serial device to the appropriate connectors on the serial device servers and driver installation, you will be able to communicate with the serial devices via its own application software and with the EKI-1526 Series device server. COM port redirector, USDG TCP server mode, TCP client mode, UDP server mode, UDP client mode, RFC2217 mode are all different methods of making a serial connection across using one or more serial device servers.

## 4.2 COM Port Redirector (Virtual COM Port)

Advantech EKI Device Configuration Utility is a serial COM port redirector that creates virtual COM ports and provides access to serial device connected to Advantech serial device server. You can configure the serial device server and enable the Virtual COM port using one integrated utility. Advantech EKI Device Configuration Utility allows you to configure Microsoft applications to communicate with network enabled serial device servers as easily as if they were physically installed in or directly connected on the PC.

The Advantech redirector can create up to 255 virtual COM ports. Application to the host can open a virtual COM port to access the serial device servers at the same time. The redirector will handle each active virtual COM port as a separate TCP connection to Advantech serial device servers.

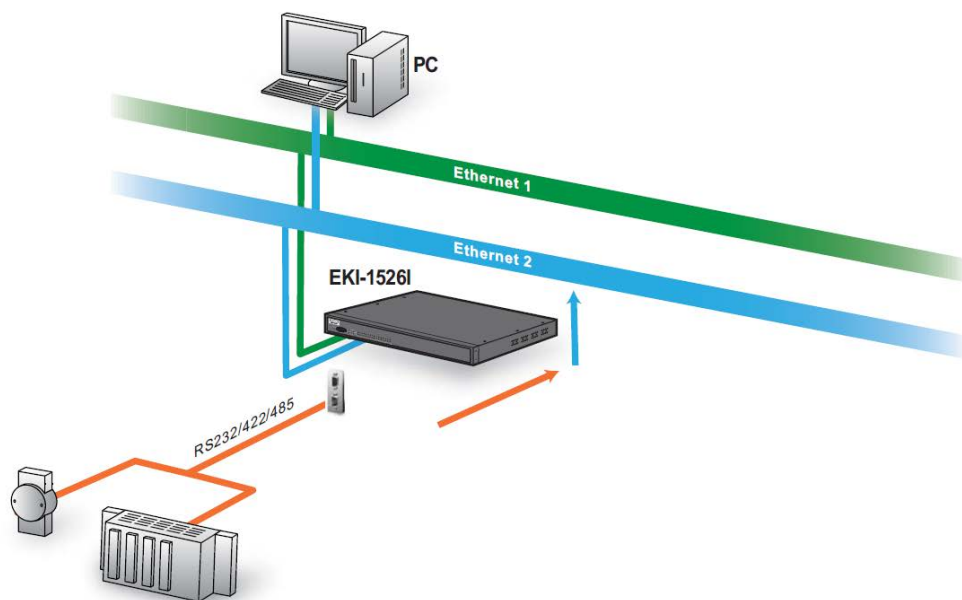
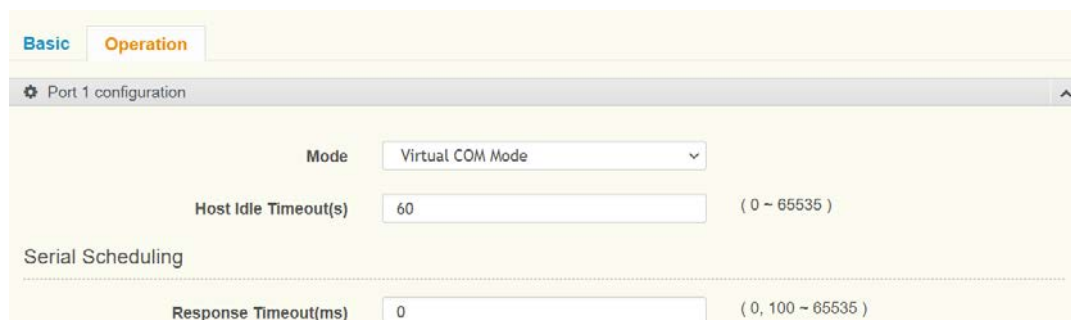

Figure 4.1 Virtual COM Mode

The EKI-1526 Series provides Multi-access function through an Ethernet connection path, allowing a maximum of five connections to open one serial port simultaneously. In this mode all connections must use the same serial setting. If one serial setting within this configuration is configured differently, the data communication will not function correctly.



**Figure 4.2 Configuring Virtual COM Mode**

The Host Idle Timeout setting monitors the connection between the host and the device. If the Host Idle Timeout setting time is reached, the device server will release the resources allocated to the port mapping. This prevents a stalled host from affecting the connective device.

**Note!** *The default value of "Host Idle Timeout" is 60 seconds.*



The Multi-access function has two modes. One is **Normal mode** and the other is **Round-Robin mode**.

### 4.2.1 Normal Mode

By setting the Response Timeout parameter to 0, the EKI-1526 Series will operate in normal mode. When multiple hosts simultaneously open the serial port, only the first connected host obtains management control; the remaining connections have data communication functionality only. Each serial port supports up to five simultaneous connections, allowing multiple hosts to transmit and receive data through the same serial port at the same time. Every host can transmit data to the same serial port, and the EKI-1526 Series will also transmit data to every host. When multiple hosts transmit data to the same serial port simultaneously, the received data from Ethernet and the serial port outputs are mixed. When the EKI-1526 Series receives data from the serial port, it transmits the data to all connected hosts simultaneously.

### 4.2.2 Round-Robin Mode

If the Response Timeout value is between 0 and 65,535, the EKI-1526 Series operates in Round-Robin mode. Each serial port supports up to five simultaneous connections, allowing hosts to transmit and receive data through the same serial port at the same time. Every host can transmit data to the same serial port, and the EKI-1526 Series processes the data in the order it arrives. The EKI-1526 Series processes the first host's request and replies. The serial device server determines the end of the serial acknowledgment through a response timeout.

---

When the EKI-1526 Series serial device server does not receive a response from the serial port after a response timeout query, the device replies with an acknowledgment and then processes the next host request. With an increased number of hosts, response time may be lengthy, increasing the Response Timeout period.

**Frame Break** is an important parameter for Round-Robin mode. It is a smart method for reducing ineffective waiting periods and streamlining the transmission process.

If the **Frame Break** function is disabled, EKI-1526 Series devices will wait for a Response Timeout period, whether or not the device has transmitted data. During this period, host commands are queued and processed in the order received.

If Frame Break is enabled and the serial port remains idle longer than the Frame Break period, the EKI-1526 Series assumes the communication is complete and continues with the next query. This is an efficient way to reduce waiting time and improve performance..

**Note!** *The Respond Timeout is used in some multiple access applications, for applications with single access by a TCP client, this option is not needed.*



## 4.3 USDG Data Mode

The EKI-1526 Series can function as either a Data TCP server or a Data TCP client. Both operations support TCP and UDP protocol. The EKI-1526 Series allows you to treat your serial devices as if they were networking devices. You can issue commands or transmit data from serial devices, connected to a EKI-1526 Series device, to any devices that are connected to the Internet.

### 4.3.1 USDG TCP Client Mode

In TCP Client mode, the TCP connection is established from the EKI-1526 Series device server. This operation mode supports a maximum of 16 simultaneous connections for each serial port on the EKI-1526 Series, either to a single host or multiple hosts. You can configure the IP address and TCP port number of the network hosts connected to the EKI-1526 Series device server using the Advantech Serial Device Server Configuration Utility.

After configuring the devices, when the EKI-1526 Series device server receives data from the serial port, it connects to the configured hosts.

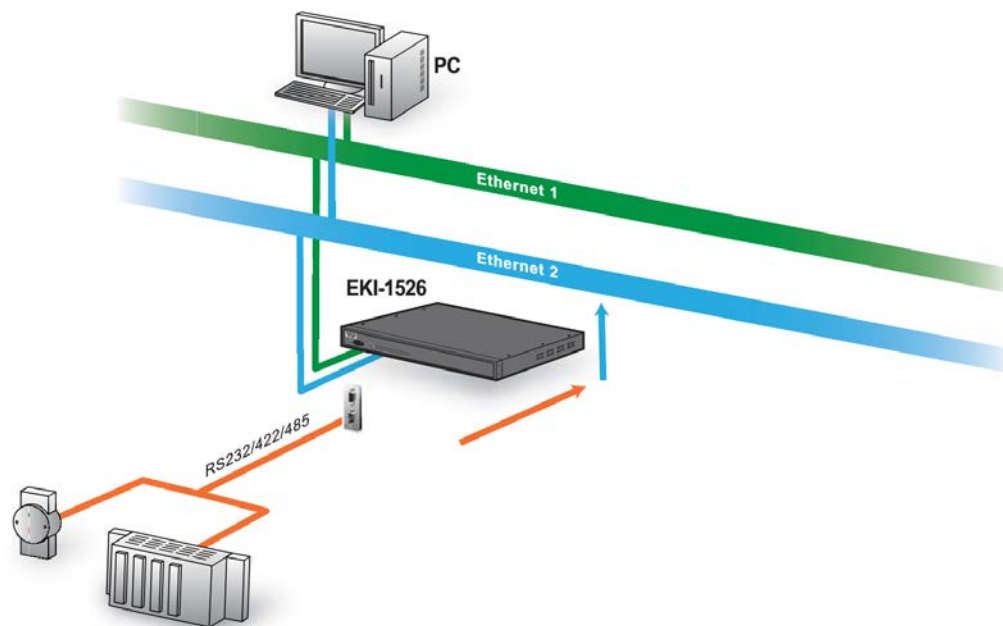

**Figure 4.3 USDG TCP Client Mode**

In USDG Data TCP Client mode, you may need to enable the peer numbers you would like to receive. You can set a maximum sixteen network devices to which you may connect. You need to fill out the IP Address and Port (including local port and peer port) of each network device to which you want to connect.

In the Peer for Receiving Data menu, entering “0” as the value for the Local Port will assign a random TCP Port for an EKI-1526 Series device.

Transmit Target Peers

Peer Number

#	Local Port	Peer IP address	Port

**Figure 4.4 Peers for Receiving Data**

### 4.3.2 USDG Data TCP Server mode

In TCP server mode, the TCP connection is initiated from the host to the EKI-1526 Series device server. This operation mode supports a maximum of five simultaneous connections for each serial port on an EKI-1526 Series device server from a single or multiple hosts. However, a multi-host connection simultaneously transmits the data from a single serial port.

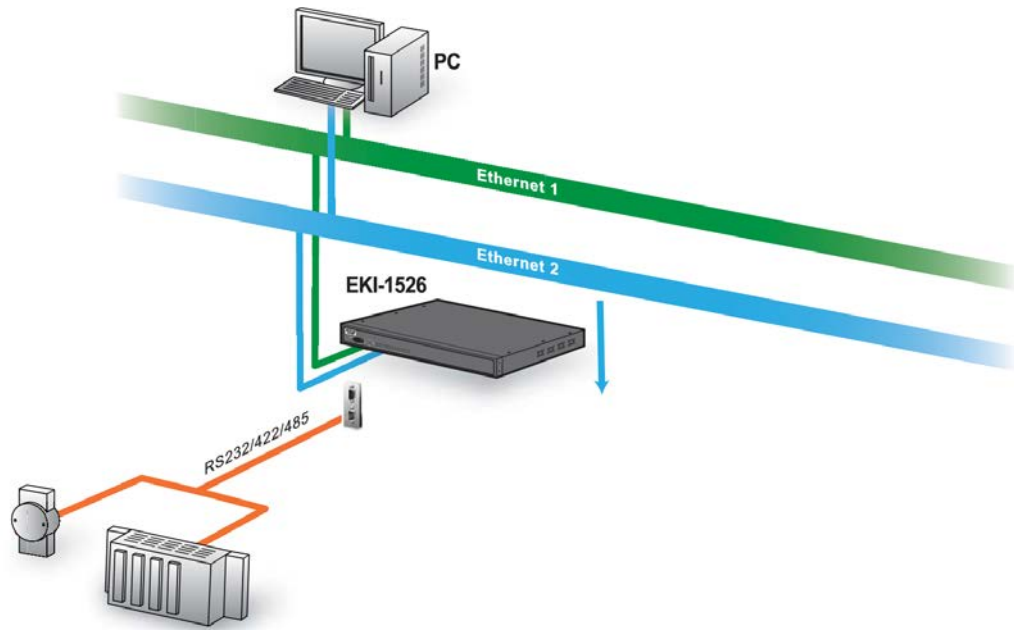

Figure 4.5 USDG TCP Server Mode

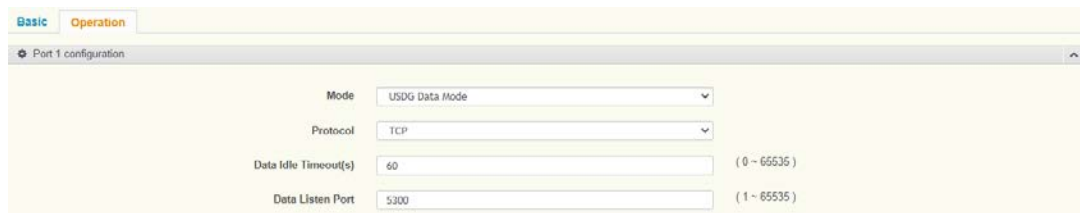

Figure 4.6 USDG Data Mode

### 4.3.3 USDG UDP Server/Client Mode

The USDG UDP mode is primarily used for the broadcasting of messages over a network. In UDP server mode, data is transmitted from the Host connected to the EKI-1526 Series USDG UDP Port (Default Port 5300). In the default UDP client mode, EKI-1526 Series device servers simultaneously transmit UDP messages to a maximum of 16 peers.

For detailed information on USDG Data Mode features and settings, please refer to Chapter 6: Web Interface Port Configuration > Port 1 (or Port 2) Operation > USDG Data Mode page (6.7.22).

## 4.4 USDG Control Mode

In controlling mode, the EKI-1526 Series device server presents a modem interface to the attached serial device: it accepts AT-style modem commands to connect / disconnect to other networking device.

If you want a serial device running application program to connect/disconnect to different devices on request, this function is available through the USDG Control mode.

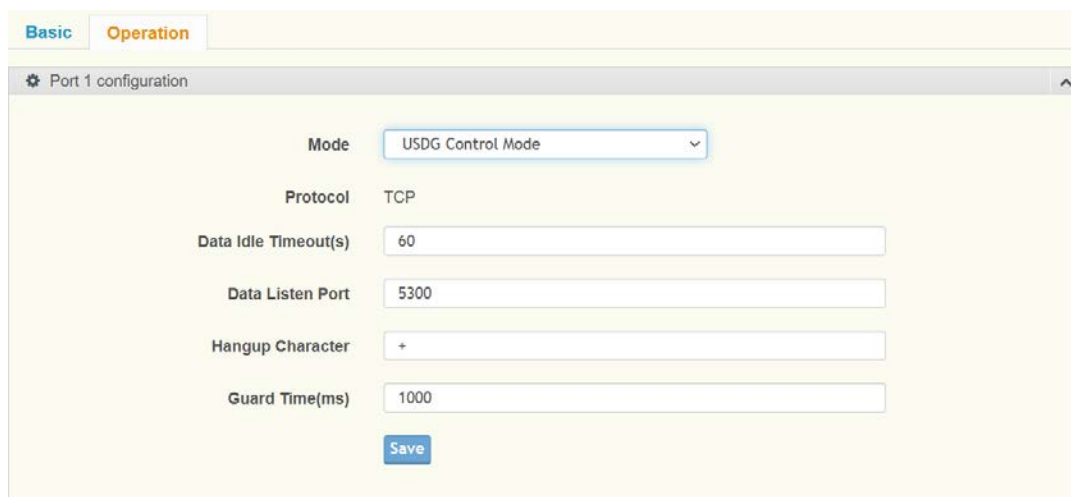

The screenshot shows a web-based configuration interface for 'Port 1 configuration'. It features two tabs: 'Basic' and 'Operation', with 'Operation' selected. The configuration fields are as follows:

Field	Value
Mode	USDG Control Mode
Protocol	TCP
Data Idle Timeout(s)	60
Data Listen Port	5300
Hangup Character	+
Guard Time(ms)	1000

A 'Save' button is located at the bottom of the configuration area.

Figure 4.7 USDG Control Mode

### 4.4.1 Hangup Character

The default character is “+”. After you have connected to another serial device an via EKI-1526 Series device, you may need to disconnect, using the command “+++”. To do this, press “+” three times and wait for the Guard timeout <default value is 1000ms>; the device will disconnect. You can set “Guard Time” to define the idle time.

## 4.4.2 Guard Time

The default value is 1000 ms.

Example: <Guard Time>+++<Guard Time>

**Table 4.1: Guard Time**

Command	Function
ATD <IP address><TCP port><CR>	Forms a TCP connection to the specified host. Ex: ATDT 192.0.55.22:5201 In above example, the EKI-1526 Series device server forms a raw TCP connection to the networking device (192.0.55.22). The TCP port is 5201.
ATA <CR>	Answering an incoming call
+++<CR>	Returns the user to the command prompt when entered from the serial port during a remote host connection.
<LF><CR> OK <LF><CR>	Commands are executed correctly
<LF><CR> CONNECT <LF><CR>	Connect to other device
<LF><CR> RING ddd.ddd.ddd <LF><CR>	Detect the connection request from other device, which IP address is ddd.ddd.ddd.ddd.
<LF><CR> DISCONNECT <LF><CR>	Disconnect from other device
<LF><CR> ERROR <LF><CR>	Incorrect commands
<LF><CR> FAIL <LF><CR>	If you issue an ATDT command and can not connect to the device, it will response "FAIL".

## 4.5 RFC2217 Mode

RFC2217 mode is similar to virtual COM mode in that a driver is used to establish a transparent connection between a host computer and a serial device by mapping the serial port on EKI-1526 Series devices to a local COM port on a host computer. RFC2217 defines general COM port control options based on the Telnet protocol. Third party drivers supporting RFC2217 are widely available on the Internet and can be used to implement virtual COM mapping to the serial port of your device.

## 4.6 SSH Console Mode

SSH console mode is designed to expose the serial console interface via SSH protocol; this function allows users to set up out-of-band management for network switches routers and firewalls. It can also be helpful for building test beds for centralized research and development labs.

# Chapter 5

Setting up Virtual COM

## 5.1 Setting COM Port Redirector

Advantech COM port mapping software is a serial COM port redirector that creates virtual COM ports and provides access to serial devices connected to an Advantech serial device server. Your serial device applications can communicate with serial devices connected to the Advantech serial device servers without software changes. Since the virtual COM ports work like standard Windows COM ports, your application software sees no difference between a local serial device and one connected to an Advantech serial device server.

The COM redirector utility and the virtual COM port management utility are integrated into one utility with same GUI. The Advantech Serial Device Server Configuration Utility can create all Virtual COM ports using the Auto Mapping function or by using the manual mapping function.

## 5.2 Virtual COM Port Mapping

### 5.2.1 Auto Mapping

1. On your desktop, navigate to **Start > EKI Device Configuration Utility** and click **Advantech EKI Device Configuration Utility** to open the utility.
2. Under Serial Device Servers, locate your server and click the icon to expand the listing.
3. Select the target device and right-click on it to open up the options menu window.
4. Locate Auto Mapping and select it.

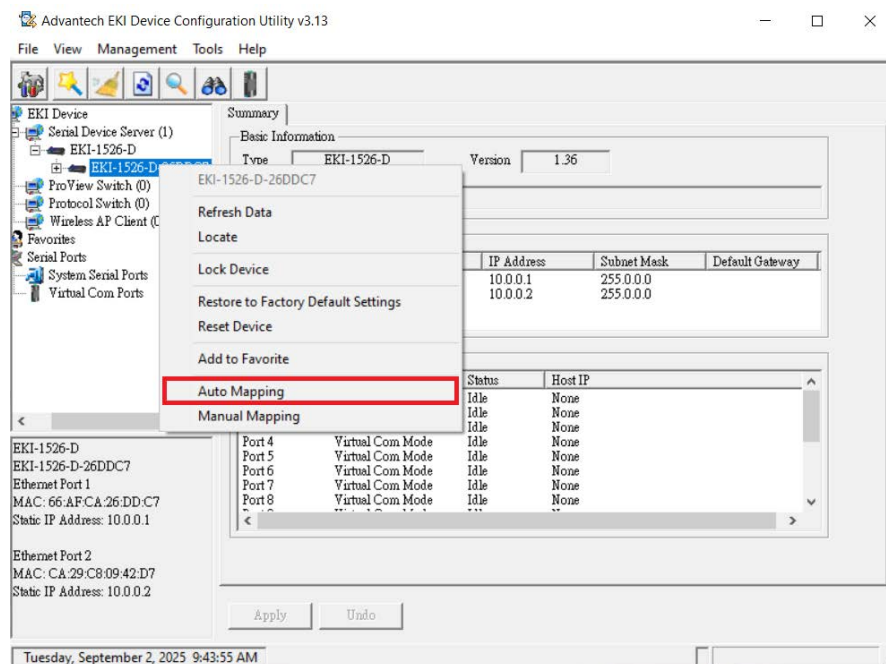

Figure 5.1 Selecting Auto Mapping

The **Batch Automatic Mapping Virtual COM Port** window displays.

5. Locate From System Port and click the drop-down menu to select the target COM port.

- From the network address list, select the address options to map.

The selected address displays the Device Port and (EKI-1526 Series device server physical serial port) and the system port which will be the VCOM port for the PC.

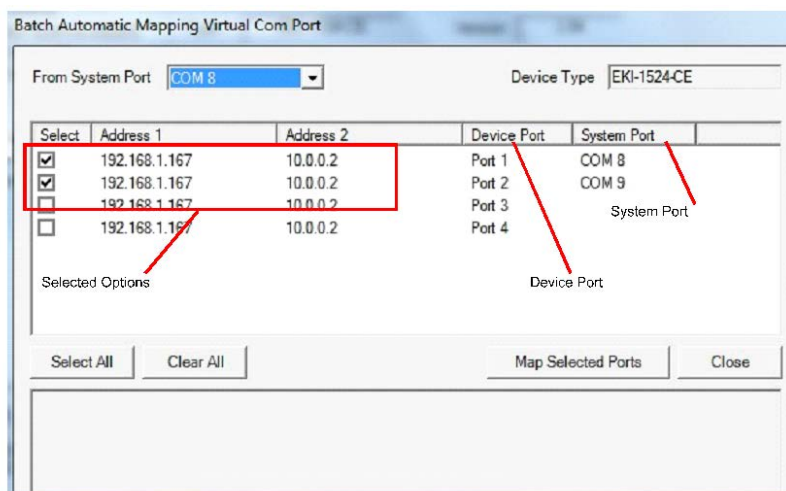

**Figure 5.2 Selecting Auto Mapping**

- From the network address list, select the address options to map.
- Click Map Selected Ports to set the configuration.

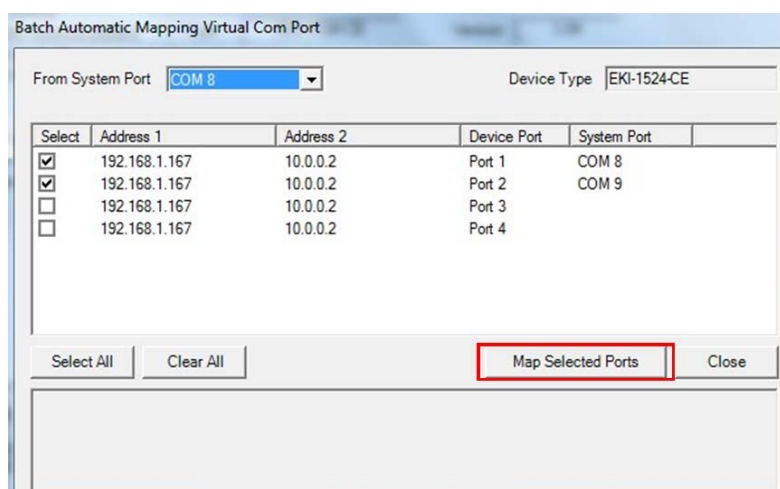

**Figure 5.3 Mapping Selected Ports**

Once the mapping function is initialized, a successful mapping process results in the virtual mapping of the designated physical serial port and VCOM PC port. See the following figure.

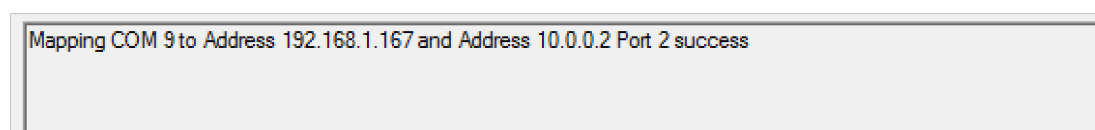

**Figure 5.4 Viewing VCOM Mapping Results**

## 5.2.2 Manual Mapping

1. On your desktop, navigate to Start > Configuration Utility and click utility.
2. Under Serial Device Servers, locate your server and click the icon to expand the listing.
3. Select the target device and right-click on it to open up the options menu window.
4. Locate Manual Mapping and select it.

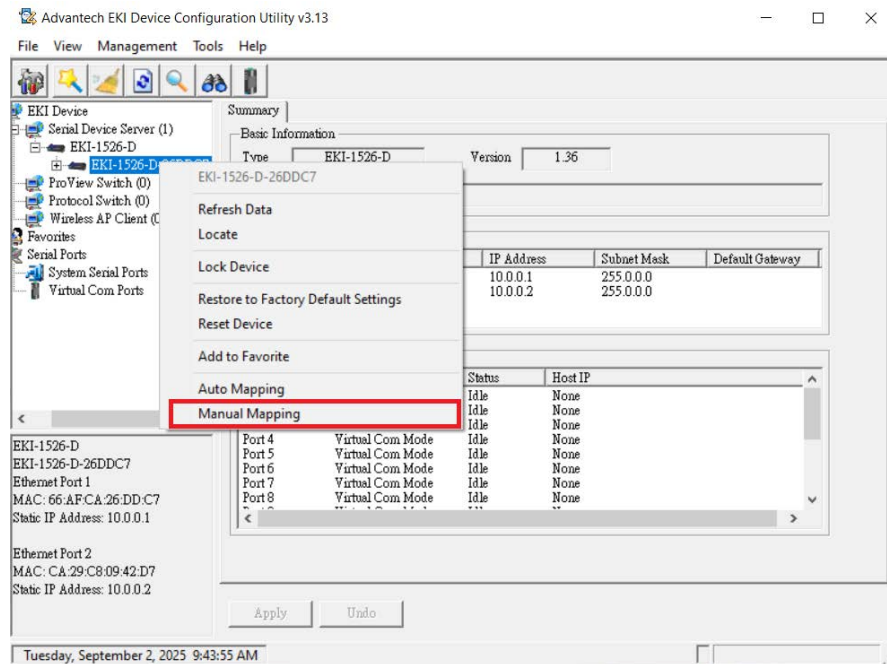

Figure 5.5 Selecting Manual Mapping

The Manual Mapping Virtual COM Port window displays.

5. In the Device > Serial Port drop-down menu, select the target port to map. This is the physical serial port on the EKI-1526 Series device.
6. In the Host > COM Port drop-down menu, select the target COM port to map. This is the virtual port on the target PC.

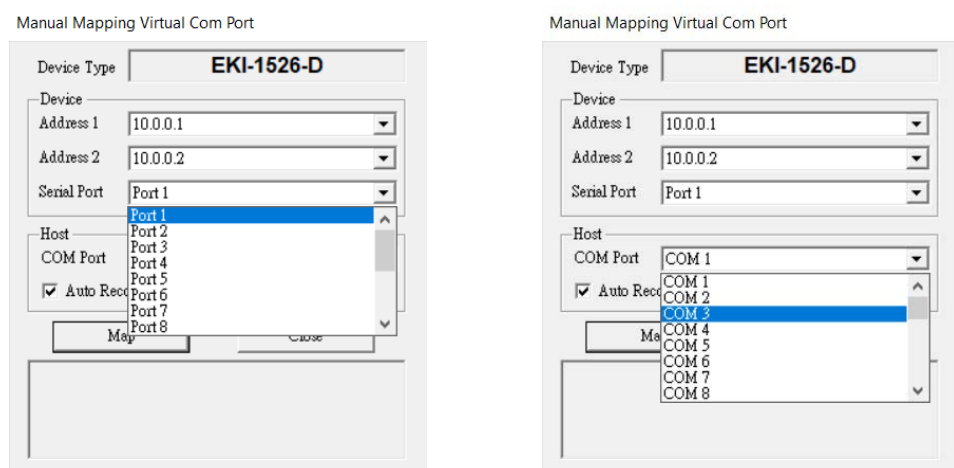
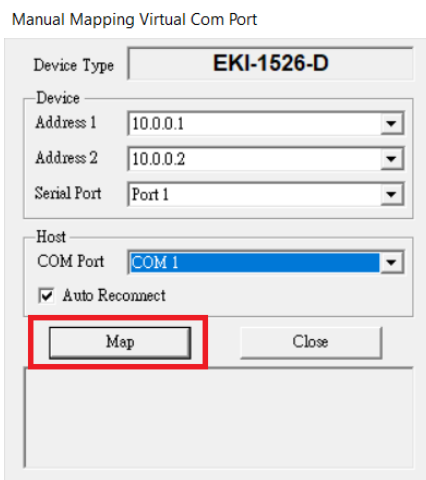

Figure 5.6 Viewing Manual VCOM Mapping Results

- Click Map it to continue the process. The mapping process may require a short time. Once this step is completed, the Manual Mapping Virtual COM Port window displays again to map the VCOM port on the target PC. Once the mapping function is initialized, a successful mapping process results in the virtual mapping of the designated physical serial port and VCOM PC port. See the following figure.

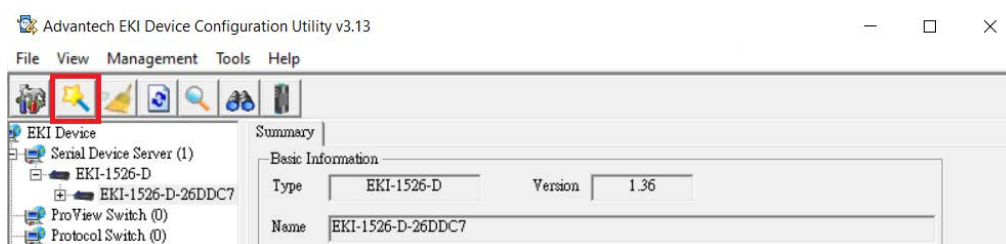

**Figure 5.7 Viewing Manual VCOM Mapping Results**

To allow for an automatic connection after a reboot or a power up, click the Auto Reconnect option to enable this function.

### 5.2.3 Configuration Wizard

- On your desktop, navigate to **Start > EKI Device Configuration Utility** and click **Advantech EKI Device Configuration Utility** to open the utility.
- Under Serial Device Servers, locate your server and click the icon to expand the listing.
- From the tool bar, select Configuration Wizard.



**Figure 5.8 Selecting the Configuration Wizard**

The Wizard screen displays and lists available devices.

- Select the target device and click **Next** to continue. The Wizard Device Settings window displays.
- Under Serial Port Settings, click the **Type** drop-down menu and select the port type. Review the settings under the Ethernet fields and verify them.
- Click **Next** to continue or **Previous** to return to the previous screen. The selected settings are displayed in the following Wizard window.

7. Locate the radio button correlating to the target port to modify and click on it to select it. Verify the Device Port (EKI-1526 Series device physical serial port) and System Port (virtual COM port for PC) settings before continuing.
8. Click **Finish** to complete the process. A Wizard complete! screen displays indicating the completion of a successful procedure.

## 5.2.4 Confirming Virtual COM Settings

1. On your desktop, navigate to **Start > EKI Device Configuration Utility** and click **Advantech EKI Device Configuration Utility** to open the utility.
2. Locate Serial Ports menu in the menu pane and click on the Expand icon next to Virtual COM Ports to view a list of the mapped ports.
3. Select a VCOM port to view its settings.

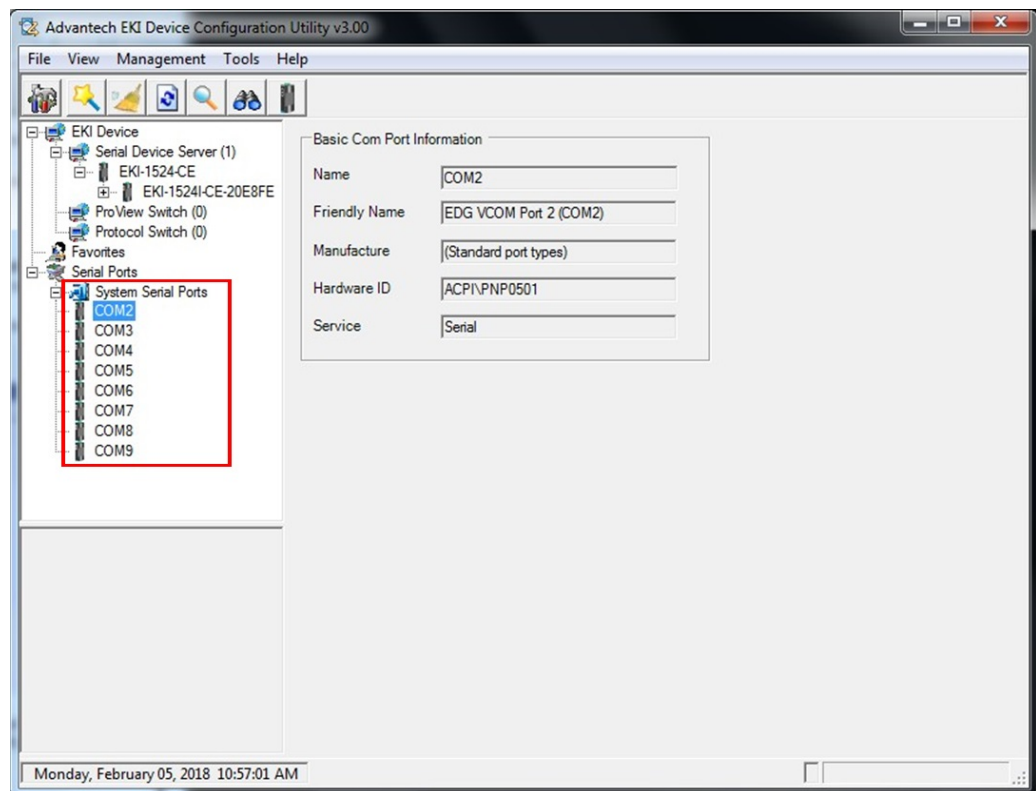

**Figure 5.9 Serial Port Listing on EKI-1526 Series Device**

For the next step, you will need to open the device manager on your system. Using the Device Manager, you can both view and change the COM port settings.

**Note!** *The following instructions were developed in a Windows 7 environment; the Windows XP equivalent is displayed in parentheses (). Instructions may vary according to the operating system used.*



4. On your desktop, click on the **Start** button and then on **Control Panel**. A window displays showing all the available control panels.
5. Click on **Hardware and Sound (Hardware)**. A list of all available hardware configuration options displays.

6. Under **Devices and Printers**, click on the **Device Manager** link. A new window displays showing a list of all the available devices on your computer.
7. Locate **Ports (COM & LPT)** and click on the expand icon. A list of all available serial and parallel port devices display.

The newly mapped VCOM port should be listed under the same mapped settings used in the previous steps.

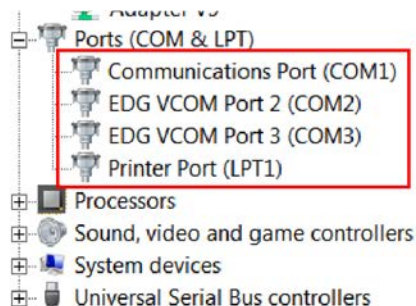

**Figure 5.10 System Port VCOM Mapping Configuration**

The newly mapped VCOM port is listed under the same mapped settings used in the previous steps. The settings correspond to the VCOM port configuration on the EKI-1526 Series device, see the following figure.

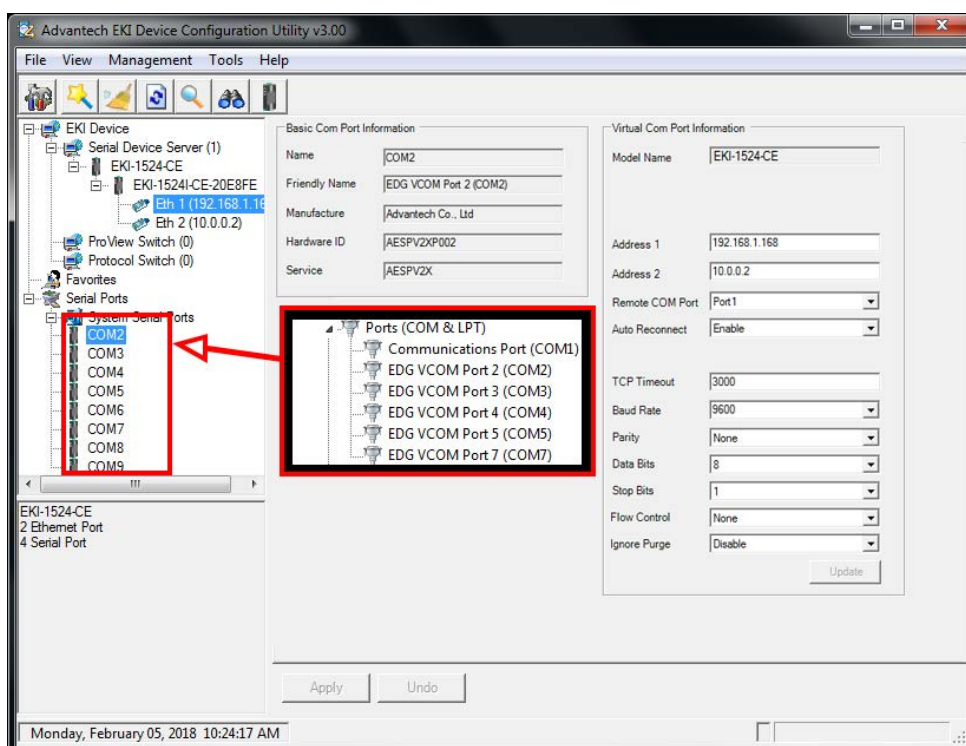

**Figure 5.11 Verifying VCOM Mapping Configuration**

If the settings do not correspond, the VCOM mapping is not correct. See “Virtual COM Port Mapping” on page 62 to re-map the VCOM ports.

## 5.2.5 Removing VCOM Ports

1. On your desktop, navigate to **Start > EKI Device Configuration Utility** and click **Advantech EKI Device Configuration Utility** to open the utility.
2. Under Serial Ports, click the expand icon on Virtual COM Ports to view the configured port list.
3. Locate the port to remove and right-click on it to open the options menu.
4. Scroll down to **Remove This Port** and click on it to initiate the procedure.

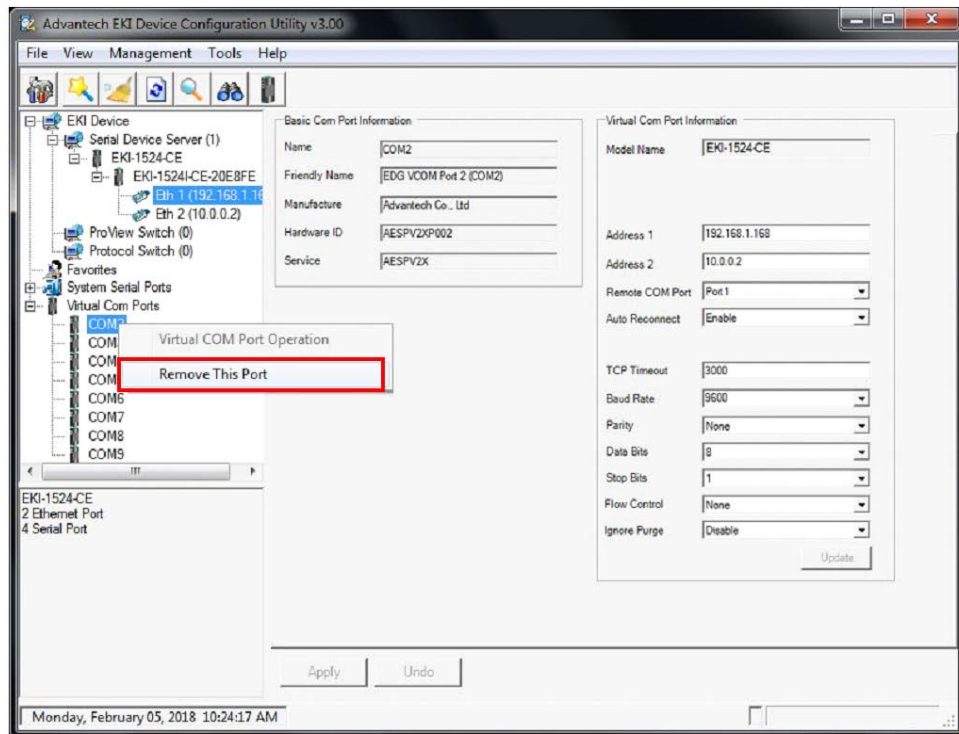

Figure 5.12 Remove VCOM Port

A Remove Port confirmation window displays.

5. Click OK to continue with the removal process or Cancel to return to the previous menu.  
Once the procedure is completed, a prompt displays the successful removal of the port from the VCOM mapping list.

## 5.2.6 Exporting and Importing VCOM Mapping

Importing and exporting Virtual COM Port Mapping is useful when the factory has already used a number of serial device servers in VCOM mode. You can easily upgrade to a new utility, and don't need to re-map the Virtual COM Ports. For example, when you would like to upgrade from Utility 1.71 to Utility 3.0, you can export your own mapped Virtual COM Ports in Utility 1.71 and save them as a \*.cpm file. After upgrading to Utility 3.0, import your \*.cpm file and restore your own Virtual COM Ports.

**Note!** This Virtual COM Port Mapping tool can only recover Virtual COM Ports that have been mapped previously. For newly installed serial device servers, please follow the virtual COM Port mapping steps.



1. On your desktop, navigate to **Start > EKI Device Configuration Utility** and click **Advantech EKI Device Configuration Utility** to open the utility.
2. Locate Serial Ports menu in the menu pane and click on the Expand icon next to Virtual COM Ports to view a list of the mapped ports.
3. Select a VCOM port.
4. Click Import Virtual COM Port Mapping or Export Virtual COM Port Mapping in the File menu.

## 5.3 Running a Diagnostic Test

The loopback test allows you to determine if the EKI-1526 Series device server is configured correctly to identify any failed nodes in the network. The test allows you to send a signal from the server and return (looped back) it back to the server.

1. Connect the loopback connector to a COM port on the EKI-1526 Series device server.
2. On your desktop, navigate to **Start > EKI Device Configuration Utility** and click **Advantech EKI Device Configuration Utility** to open the utility.
3. Under Serial Ports, click the expand icon on Virtual COM Ports to view the configured port list.
4. Open the ICOMToolsPlus utility to open the EKI-1526 Series device server settings.
5. Set the COM port configuration to match the Port Configuration.
6. Click the Start menu.

A successful loop back test incrementally displays the Bytes/sec values on both displayed menus.



# Chapter 6

Web Interface

## 6.1 Overview

The EKI-1526 Series serial device server can be configured through a web interface. By using a standard web browser, the same procedure as with the Windows configuration utility can be used. In the browser's address field, enter the IP Address of your EKI-1526 Series serial device server. The default IP setting is 10.0.0.1, but you should use the IP which you have previously assigned for this device. Once the IP is entered, you will be presented with the following windows.

**Note!** *Before using the web-based configuration, make sure your host PC Ethernet network IP domain is as same as the serial device server, or it can establish the TCP connection with the serial device server.*



**Note!** *It is recommended that you use Microsoft Internet Explorer 7.0 or higher.*



**Note!** *Any changes made to the web page functionality will only take effect after a reboot.*



## 6.2 Accessing the Web Page

### 6.2.1 Accessing the Web Page via Configuration Utility

To access the web page via configuration utility:

1. Select Ethernet under the desired device.
2. Click **Launch Browser**.

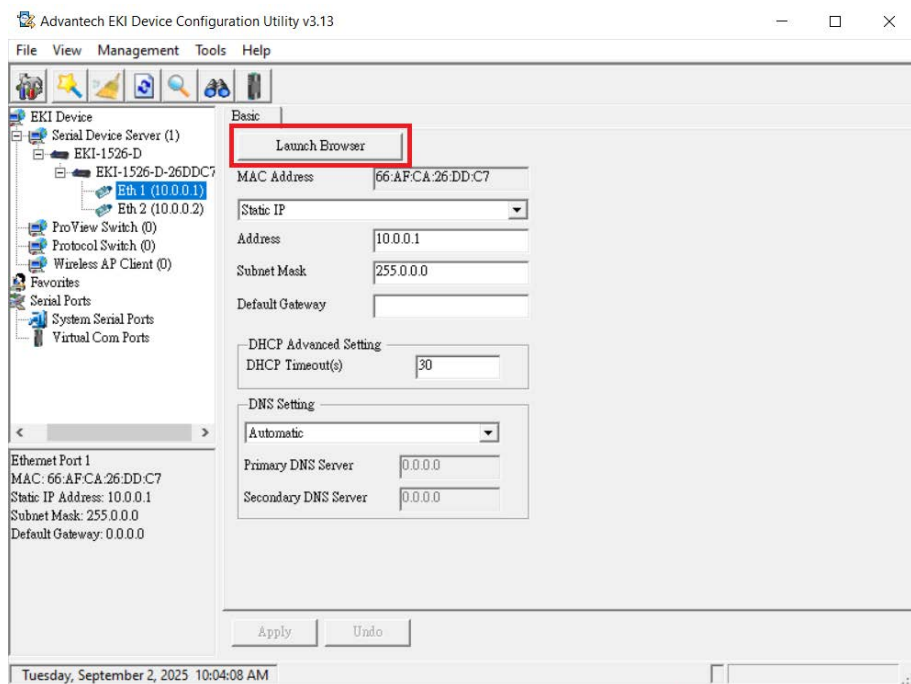

Figure 6.1 Accessing the Web Page via Configuration Utility

## 6.2.2 Accessing the Web Page via Web Browser

Once the device is installed and connected, power on the device. The following information guides you through the logging in process.

1. Launch your web browser on the PC.
2. In the browser's address bar, type the device's default IP address (Eth1: 10.0.0.1, Eth2: 10.0.0.2).  
The main menu is shown.

## 6.3 System

You can change the Device Name and Device Description on this page. You can also enable or disable the Telnet and SNMP functions. Moreover, you can set the Time zone related settings.

To access this page, click **System**.

The screenshot displays the 'System Configuration' web interface. It includes the following sections and settings:

- Firmware version:** 1.32
- Revision number:** 6950
- Device Name:** Device Name
- Device Description:** Device Description
- VCOM Ignore Device ID:**  Disable  Enable
- Telnet:**  Disable  Enable
- SSH:**  Disable  Enable
- SNMP:**  Disable  Enable
- SSDP:**  Disable  Enable
- Local Time:**
  - Year: 2024
  - Month: 12
  - Day: 10
  - Hour: 17
  - Minute: 54
  - Second: 5
- Time Zone:** (GMT +0)
- Time Server:** Time Server
- Daylight Saving Time:**  Disable  Enable
- Start Time:** First, Sunday, January, HH:MM
- End Time:** First, Sunday, January, HH:MM
- Time Zone Offset:** min. (-120 - 120)
- Virtual Gateway Settings:**
  - Virtual Gateway:**  Disable  Enable
  - Interface:** Eth 1
  - Virtual IP:** Virtual IP
  - ID:** 1 (1 - 255)
  - Priority:** Primary

A 'Save' button is located at the bottom of the form.

**Figure 6.2 System**

The following table describes the items in the previous figure.

**Table 6.1: System**

Item	Description
Firmware Version	Displays the current firmware version of the device.
Revision Number	Displays the revision number of the device.
Device Name	Enter the device name: up to 31 alphanumeric characters.
Device Description	Enter the device description.
VCOM Ignore Device ID	Click <b>Enabled</b> or <b>Disabled</b> to enable or disable VCOM ignore device ID.
Telnet	Click <b>Enabled</b> or <b>Disabled</b> to set remote access through the Telnet Service function.
SSH*	Click <b>Enabled</b> or <b>Disabled</b> to set remote access through the SSH Service function.
SNMP	Click <b>Enabled</b> or <b>Disabled</b> to define the SNMP daemon.
SSDP	When enabled, the gateway is discoverable on a Windows network. When disabled, the gateway is discoverable by the EKI Device Configuration Utility.
Local Time	Enter the year, month, day, hour, minute and second. <ul style="list-style-type: none"> <li>■ The year must be entered in 4-digit format.</li> <li>■ The time must be entered in 24-hour format.</li> <li>■ All six fields must have values.</li> </ul>
Time Server	Enter the address of the SNTP server. This is a text string of up to 64 characters containing the encoded unicast IP address or hostname of a SNTP server. Unicast SNTP requests will be sent to this address. If this address is a DNS hostname, then that hostname should be resolved into an IP address each time a SNTP request is sent to it.
Daylight Saving Time*	To use automatic Daylight-Saving Time adjustment, enable the feature then select the starting and ending times and time zone offset.
<b>Virtual Gateway Settings</b>	
Virtual Gateway COM Port Redundancy	
Interface	Select an Ethernet Interface (Eth1/Eth2)
Virtual IP	Enter an IP address for the virtual gateway. This address will be used to access the group of gateways as one device. Enter the same Virtual IP address for all devices participating in the virtual gateway.
Virtual Gateway*	Enter a Modbus ID for the Virtual Gateway. Enter the same ID for all devices participating in the virtual gateway.
Priority	Select a priority for this device (i.e., Primary, Secondary, Third or Fourth). Only one device will be active at any time. If the highest priority device becomes unavailable, the next lower priority device will become active.
Save	Click <b>Save</b> to save the values and update the screen.

## 6.4 Service

The Service tab contains menu options for configuring the VCOM, USD, Web Server, SSH Console Setting, and RADIUS/LDAP/Local user management.

### 6.4.1 VCOM

VCOM retains its earlier functionality, along with the advanced VCOM Security features. The default is VCOM 2.0 protocol version to enable new parameters across several areas of the UI and enhances serial data transmission.



Figure 6.3 VCOM 1.0

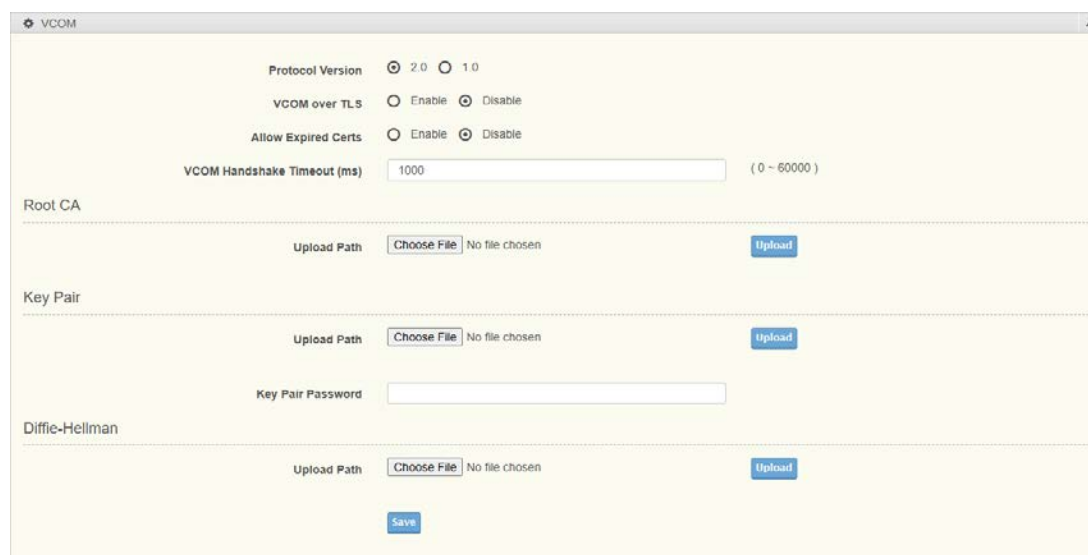

Figure 6.4 VCOM 2.0

The following table describes the items in the previous figure.

Table 6.2: VCOM	
Item	Description
VCOM over TLS	Click to enable or disable virtual COM using a TLS connection encrypts all data sent between serial interface.
Allow Expired Certs	Click to enable or disable using expired certificate. However, there are many security risks to using an expired SSL certificate.
VCOM Handshake Timeout (ms)	Enter the VCOM Handshake Timeout time to ensure a secure connection by preventing TLS handshake errors, as it defines the duration (ms) a virtual COM port waits for a successful handshake before terminating the connection if unsuccessful.
Root CA	The Root CA signs certificates that are used to authenticate the identity of the devices or servers in a TLS-secured communication.

**Table 6.2: VCOM**

Upload Path	Click Browse to select a Root CA public key for the VCOM over TLS. Click Upload to import the selected file. Click Delete to remove the selected file. Click + Show Details to view the details of the selected key.
Key Pair	A Key Pair consists of a private key and a public key. The public key is embedded in its TLS certificate (signed by a CA), and the private key is used to decrypt incoming data encrypted with the public key.
Upload Path	Click Browse to select a Key Pair for the VCOM over TLS. Click Upload to import the selected file. Click Delete to remove the selected file. Click + Show Details to view the details of the selected key.
Key Pair Password	Enter a password to protect the private key within the Key Pair.
Diffie-Hellman	Allows the server and client to securely agree on a shared encryption key for their session without transmitting it over the network.
Upload Path	Click Browse to select a Key Pair for the VCOM over TLS Click Upload to import the selected file. Click Delete to remove the selected file. Click + Show Details to view the details of the selected key.
Save	Click Save to save the values and update the screen.

## 6.4.2 USDG

USDG retains its earlier functionality, along with the advanced USDG Security features. The default is USDG 2.0 protocol version to enable new parameters across several areas of the UI and enhances data transmission.



**Figure 6.5 USDG1.0**

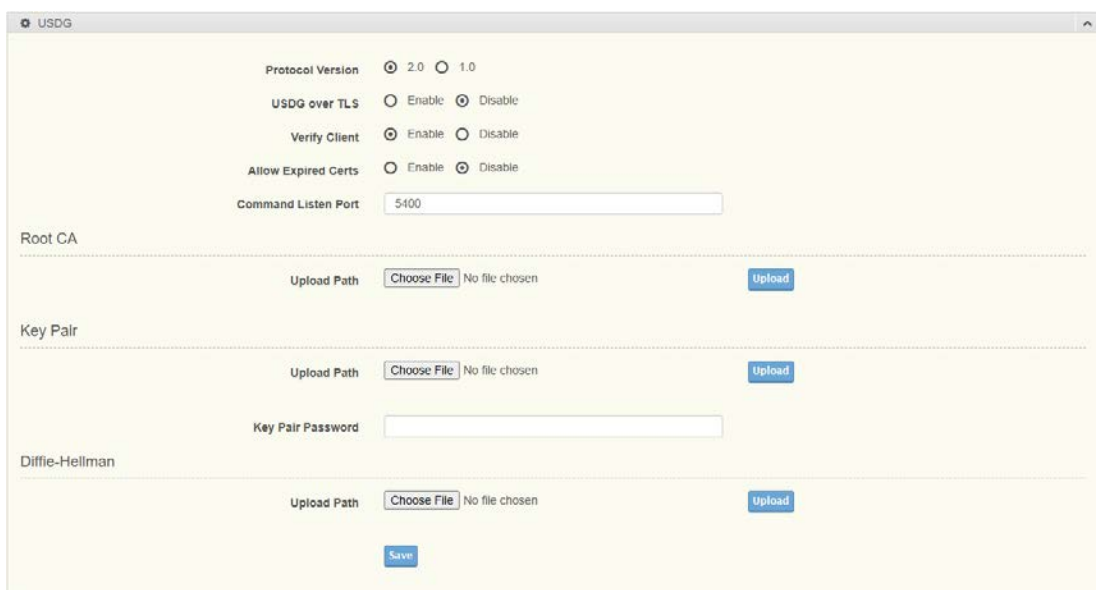

**Figure 6.6 USDG 2.0**

The following table describes the items in the previous figure.

Table 6.3: USDG	
Item	Description
USDG over TLS	Click to enable or disable virtual COM using a TLS connection encrypts all data sent between serial interface.
Verify Client	Verify the client's signature.
Allow Expired Certs	Click to enable or disable using expired certificate. However, there are many security risks to using an expired SSL certificate.
Command Listen Port	Enter a value to identify the command listen port for accepting connected request of other network device. Each port has its own command listen port to accept connection requests from other network devices, so the command listen port cannot be set to the same value. The Command Listen Port is different from the Data Listen port. <Default Port is 5400>
Root CA	The Root CA signs certificates that are used to authenticate the identity of the devices or servers in a TLS-secured communication.
Upload Path	Click Browse to select a Root CA public key for the USDG over TLS. Click Upload to import the selected file. Click Delete to remove the selected file. Click + Show Details to view the details of the selected key.
Key Pair	A Key Pair consists of a private key and a public key. The public key is embedded in its TLS certificate (signed by a CA), and the private key is used to decrypt incoming data encrypted with the public key.
Upload Path	Click Browse to select a Key Pair for the USDG over TLS. Click Upload to import the selected file. Click Delete to remove the selected file. Click + Show Details to view the details of the selected key.
Key Pair Password	Enter a password to protect the private key within the Key Pair.
Diffie-Hellman	Allows the server and client to securely agree on a shared encryption key for their session without transmitting it over the network.
Upload Path	Click Browse to select a Diffie-Hellman for the USDG over TLS. Click Upload to import the selected file. Click Delete to remove the selected file. Click + Show Details to view the details of the selected key.
Save	Click Save to save the values and update the screen.

### 6.4.3 Web Server

The EKI-152x web interface uses the unsecure http protocol by default, but can be configured to use https for added security. When HTTPS is enabled, communication between the web browser and the EKI device is encrypted using an SSL certificate.

An HTTPS connection is required if you plan to update the device firmware using the web interface instead of using the utility provided with the firmware.

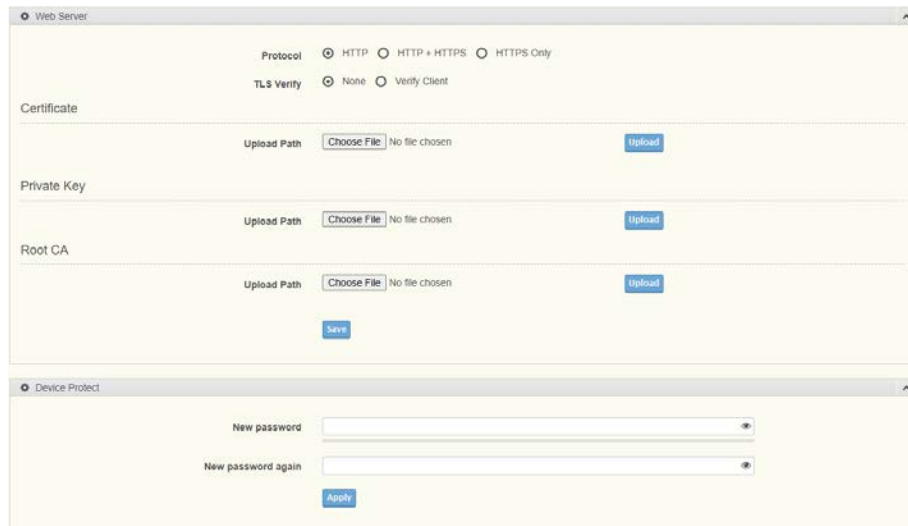
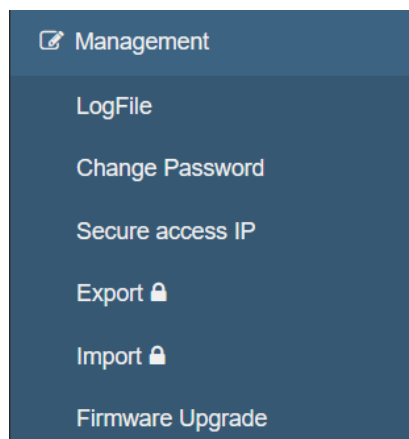

**Figure 6.7 Web Server**

The following table describes the items in the previous figure.

**Table 6.4: Web Server**

Item	Description
Protocol	Choose HTTP, HTTP + HTTPS, or HTTPS Only for the web server, with HTTPS offering secure, encrypted communication through valid certificates.
TLS Verify	The TLS Verify function is required for the HTTPS protocol; select Verify Client for mutual authentication, or None if this function is not needed.
Certificate	After enabling https support, choose a .pem file containing your SSL certificate and click Upload.
Private Key	After enabling https support, choose a .pem file containing your private key and click Upload.
Root CA	After enabling HTTPS support, uploading Root CA to securely establish an HTTPS connection.
Save	Click Save to save the values and update the screen.
Device Protect	Set a password to enable the Device Protect function, which encrypts the device configuration file; after activation, the export and import functions will display a lock icon. (Please keep the password)



**Note!** *HTTPS will not work without a certificate and private key and Root CA. The SSL certificate and private key should both be contained in one .pem file.*



*Upload the same file as both Certificate and Private Key.*

*(Refer to Section 3.7 Create CA or Section 6.11.2 Certs Generator for certificate generation methods.)*

**Note!** *Generate the Certificates by EKI Utility on Windows. EKI Utility version should be v3.07 or later to support this function.*



**Note!** *All new configurations will take effect after rebooting. To reboot the device, click Tools > Reboot.*



#### 6.4.4 SSH Console Setting

The SSH Console Setting function allows for the setup of the system wide configurations related to the SSH console service.

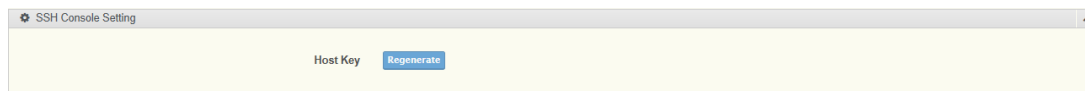

Figure 6.8 SSH Console Setting

Table 6.5: SSH Console Setting

Item	Description
Host Key	Click Regenerate to reissue the CA key for the SSH console service.

#### 6.4.5 LDAP and RADIUS Setting

The gateway can use the LDAP protocol or RADIUS protocol for user management, or user management can be controlled locally. Setting up LDAP or RADIUS integration is an advanced topic with security implications. We recommend that the LDAP or RADIUS setting be configured by your network administrator.

## 6.4.6 LDAP Setting

**Figure 6.9 LDAP Setting**

The following table describes the items in the previous figure.

**Table 6.6: LDAP Setting**

Item	Description
LDAP Server	Enter the string to indicate the IP address or DNS of the LDAP server.
LDAP Key	Enter the string to indicate the user name prefix to define the LDAP DN key.
LDAP Timeout	Enter the string to indicate the interval period between permission updates for each SSH connection.
LDAP Rapid	Enter the string to indicate the interval period between permission checks when the device detects a permission change on a SSH connection.
LDAP over TLS	Click to enable (default) or disable the LDAP over TLS function.
Root CA	
Upload Path	Click Browse to select a Root CA public key for the LDAP server. Click Upload to import the selected file. Click Delete to remove the selected file. Click + Show Details to view the details of the selected key.
Access Setting	
Port	Displays the port number of the access setting.
Config DN	Displays the DN of the directory, which holds users with permission to configure basic functions of this serial interface
Save	Click <b>Save</b> to save the values and update the screen.

## 6.4.7 RADIUS Setting

The screenshot shows the 'Radius Setting' web interface. It contains several input fields and a table. The 'Radius Server IP Address' field is empty. The 'Radius Server Port' field contains '1812' with a range '( 1 - 65535 )' to its right. The 'Radius Server Secret Passphrase' field is empty. The 'Radius Server EAP Type' is a dropdown menu set to 'MD5'. The 'Radius Timeout' field contains '60' with a range '( 0 - 86400 )'. The 'Radius Rapid' field contains '10' with a range '( 0 - 120 )'. Below these is the 'Super Access Setting' section with a 'Radius Super User Header' field containing 'ex. root/'. The 'Access Setting' section is a table with three columns: 'Port', 'Read Only Header', 'Read Write Header', and 'Config Header'. The first two columns are highlighted in yellow. The table has two rows, both with empty input fields. A 'Save' button is located at the bottom center of the form.

**Figure 6.10 Radius Setting**

The following table describes the items in the previous figure.

**Table 6.7: Radius Setting**

Item	Description
Radius Server IP Address	Enter the string to indicate the value for the address of the RADIUS server.
Radius Server Port	Enter the string to indicate the port for the RADIUS server.
Radius Server Secret Passphrase	Enter the string to indicate the passphrase used by the Radius server.
Radius Server EAP Type	Click the drop-down menu to select the value for the EAP type of the Radius server. Options: <ul style="list-style-type: none"> <li>■ MD5</li> <li>■ PEAP</li> <li>■ TTLS</li> </ul>
Radius Timeout	Enter the string to indicate the periodic time period used for checking with the RADIUS server.
Radius Super User Header	Highest authority user header
Access Setting	
Port	Displays the port number of the access setting.
Config DN	Displays the DN of the directory, which holds users with permission to configure basic functions of this serial interface
Save	Click <b>Save</b> to save the values and update the screen.

## 6.4.8 User Management

Users can be managed via LDAP, Radius or Local user management settings. If local user management is used, the user list is managed from this screen. A Web Enhanced Password must be set on the Passwords page in order to activate user management. That web password will show up on this page as the 'root' user.

**Figure 6.11 User Management**

The following table describes the items in the previous figure.

Table 6.8: User Management		
Item	Description	
Method	LDAP, Radius or Local User. The remaining settings on this page is only relevant when Local User is selected.	
Local Timeout	The system will check the privilege settings for all connected users on this timeout interval. If there's a privilege change (e.g., the user is no longer allowed), the user will be disconnected. A new user logging in will trigger a privilege check of all connected users immediately regardless of the Timeout value.	
Local Rapid	When the system discovers a privilege change, it will wait for the Rapid interval to check all users again, and will continue until all connected users have the correct privilege	
Local User Access Settings	Add	Add a new local user. Specify username and password, and enable/disable the Config attribute for each port.
	Edit	Modify the password or attributes for an existing user.
	Delete	Remove an existing user.
	Username	Enter a user name.
	Password	Enter a password.
Attribute	Enable each port that this user should be able to configure. A user must have config permission on at least one port in order to save the username in this list.	
Save	Click <b>Save</b> to save the values and update the screen.	

**Note!** All new configurations will take effect after rebooting. To reboot the device, click **Tools > Reboot**.



Changing user management setting may cause you to lose access to the device! Make sure you have access permissions with your new settings.

## 6.5 Ethernet Configuration

Choose either **Eth 1** or **Eth 2** (EKI-1211 only has **Eth 1**) in the Ethernet Configuration page. Enter the corresponding values for your network environment. Remember to press **Save** after entering all values. To access this page, click **Ethernet Configuration**.

The screenshot shows the 'Eth1 Configuration' window. It is divided into three sections: IPv4 Configuration, DNS Configuration, and Current Status. In the IPv4 Configuration section, the Mode is set to 'Static IP'. The MAC Address is 74-FE-48-7E-6B-F8. The IP Address is 10.0.0.1, Subnet Mask is 255.0.0.0, and Default Gateway is 0.0.0.0. In the DNS Configuration section, the 'Automatic' radio button is selected. The Current Status section shows IP 1 as 10.0.0.1 and IP 2 as fe80::76fe:48ff:fe7e:bb88. A 'Save' button is located at the bottom of the form.

**Figure 6.12 Ethernet Configuration**

The following table describes the items in the previous figure.

**Table 6.9: Ethernet Configuration**

Item	Description
<b>IPv4 Configuration</b>	
Mode	Select the IP Address Setting mode: <ul style="list-style-type: none"> <li>■ Static IP - Set a fixed IP configuration</li> <li>■ DHCP/AutoIP - IP configuration set by DHCP server</li> <li>■ BootP/AutoIP - IP configuration set by BOOTP server</li> <li>■ DHCP/BootP/AutoIP - accept IP configuration from either DHCP or BOOTP server</li> </ul>
MAC Address	Bridge - set up a bridge connection between the two Ethernet ports Enter the MAC address to which packets are statically forwarded.
IP Address	Enter a value to specify the IP address of the interface. The defaults are: Eth1, 10.0.0.1; Eth2, 10.0.0.2.
Subnet Mask	Enter a value to specify the IP subnet mask for the interface. The default is 255.0.0.0.
Default Gateway	Enter a value to specify the default gateway for the interface
<b>DNS Configuration</b>	
DNS	<ul style="list-style-type: none"> <li>■ Automatic: Get DNS server assignment from the DHCP server (no DNS will be assigned if the Mode is set to Static IP)</li> <li>■ Specific: Enter primary and secondary DNS server addresses</li> </ul>
<b>Current Status</b>	
IP 1	Displays the current IP address 1 of the device.
IP 2	Displays the current IP address 2 of the device.
Save	Click <b>Save</b> to save the values and update the screen.

**Note!** All new configurations will take effect after rebooting. To reboot the device, click *Tools > Reboot*.



## 6.6 Ethernet Bridge

In Ethernet Bridge mode, both Ethernet interfaces use the same IP address. Either Spanning Tree Protocol (STP) or Redundancy Mode can be used to prevent loops and provide a backup communications path.

**Figure 6.13 Ethernet Bridge Configuration**

The following table describes the items in the previous figure.

Table 6.10: Ethernet Bridge	
Item	Description
<b>IPv4 Configuration</b>	
Mode	Static IP is the only valid option for the Ethernet Bridge.
MAC Address	Enter the MAC address to which packets are statically forwarded.
IP Address	Enter a value to specify the IP address of the interface. The default is 10.0.0.3.
Subnet Mask	Enter a value to specify the IP subnet mask for the interface. The default is 255.0.0.0.
Default Gateway	Enter a value to specify the default gateway for the interface.
<b>Spanning Tree Protocol Configuration</b>	
STP	Enable to use Spanning Tree Protocol to control which Ethernet port is active. All devices on the network build a spanning tree and determine which ports should be blocked to prevent loops.
Redundant Mode	Enable to let the EKI-152x control which Ethernet port is active. The
<b>DNS Configuration</b>	

**Table 6.10: Ethernet Bridge**

DNS	Click the radio button to select the DNS mode: Automatic or Specific.
Current Status	
IP 1	Displays the current IP address 1 of the device.
Save	Click <b>Save</b> to save the values and update the screen.

**Note!** All new configurations will take effect after rebooting. To reboot the device, click **Tools > Reboot**.



## 6.7 Port Configuration

The serial port configuration menu has Basic, Operation Mode, and Advanced Settings.

### 6.7.1 Basic

The Basic menu allows for the configuration of the serial interface type, baud rate, parity, data / stop bits, and flow control for port configuration. To access this page, click **Port Configuration > Basic**.

The screenshot shows the 'Port 1 configuration' page with the 'Basic' tab selected. The configuration options are as follows:

Field	Value
Type	RS232
Baud Rate	9600
Parity	None
Data Bits	8
Stop Bits	1
Flow Control	None

A 'Save' button is located below the configuration fields.

**Figure 6.14 Port Configuration > Basic**

The following table describes the items in the previous figure.

**Table 6.11: Basic**

Item	Description
Type	Click the drop-down menu to select a serial interface: RS232, RS422, RS485 or RS485 4-WIRE
Baud Rate	Enter a value to specify the baud rate. The value should conform to the current transmission speeds of connected devices when setting the baud rate.
Parity	Click the drop-down menu to select the parity: None, Odd, Even, Mark or Space.
Data Bits	Click the drop-down menu to select the data bits: 5, 6, 7, or 8.

**Table 6.11: Basic**

Stop Bits	Click the drop-down menu to select the stop bits: 1, 1.5 or 2.
Flow Control	Click the drop-down menu to select the flow control mode: None, Xon/Xoff, RTS/CTS
Save	Click Save to save the values and update the screen.

## 6.7.2 Operation

The operation menu allows for the configuration of the mode type and related attributes for port configuration.

To access this page, click **Port Configuration > Operation**.

### 6.7.2.1 Virtual COM Mode

The screenshot shows the 'Port 1 configuration' page under the 'Operation' tab. The 'Mode' is set to 'Virtual COM Mode'. The 'Host Idle Timeout(s)' is 60. Under 'Serial Scheduling', the 'Response Timeout(ms)' is 0. Under 'Serial RX Frame', 'Character Timeout' is enabled, and 'End Character (HEX)', 'Length', and 'Break Time (ms)' are disabled. Under 'Serial Data Forwarding', 'Serial RX Forwarding' is set to 'Multicast', 'Serial Token Idle Timeout(ms)' is disabled, and 'TX Broadcast' is disabled. A 'Save' button is at the bottom.

**Figure 6.15 Port Configuration > Operation**

The following table describes the items in the previous figure.

**Table 6.12: Virtual COM Mode**

Item	Description
Mode	Click the drop-down menu to select the port configuration mode: Virtual COM Mode, USDG Data Mode, USDG Control Mode, RFC2217 Mode or SSH Console Mode
Host Idle Timeout(s)	Enter a value to define the host idle timeout period.
<b>Serial Scheduling</b>	
Response Timeout(s)	Enter a value to define the response timeout period.
<b>Serial RX Frame</b>	
Character Timeout	Enable or disable to send pack immediately by character-timeout.
End Character (HEX)	Click the option to send pack immediately by end-character.
Length	The length to request for Serial RX Frame
Break Time (ms)	Enter a value to specify the frame break time.
<b>Serial Data Forwarding</b>	

**Table 6.12: Virtual COM Mode**

Serial RX Forwarding	Unicast or multicast data from the serial device to one or multiple host computers, and the serial device can also receive data from one or multiple host computers, making this mode ideal for message display applications.
Serial Token Idle Timeout(ms)	Enter a value for serial communication will wait without receiving any data or tokens before it considers the communication idle or inactive.
TX Broadcast	Enable or Disable TX Broadcast to transmit data from one device and broadcast it to multiple destinations or devices over a serial communication interface. Multicast: All devices in the network can see the data. Unicast: Only the devices connected to the PC can see the data.

### 6.7.2.2 USDG Data Mode

The screenshot displays the 'Port 1 configuration' web interface under the 'Operation' tab. The 'Mode' is set to 'USDG Data Mode' and the 'Protocol' is 'TCP'. The 'Data Idle Timeout(s)' is 60, 'Data Listen Port' is 5300, 'Telnet IAC' is disabled, 'TCP User Timeout (s)' is 3, 'Keepalive' is disabled, 'Keep Idle Time (s)', 'Keep Interval (s)', and 'Keep Count' are all disabled. The 'Serial Scheduling' section has 'Response Timeout(ms)' set to 0. The 'Serial RX Frame' section has 'Character Timeout' disabled, 'End Character (HEX)', 'Length', and 'Break Time (ms)' all disabled. The 'Serial TX Frame' section has 'End Character (HEX)' and 'Length' disabled, and 'Modbus RTU Command' disabled. The 'Serial Data Forwarding' section has 'Serial RX Forwarding' set to 'Multicast', 'Serial Token Idle Timeout(ms)' disabled, and 'TX Broadcast' disabled. The 'Transmit Target Peers' section has 'Peer Number' set to 0. At the bottom, there is a table for 'Transmit Target Peers' with columns for '#', 'Local Port', 'Peer IP address', and 'Port', and a 'Save' button below it.

**Figure 6.16 Port Configuration > Operation > USDG Data Mode**

The following table describes the items in the previous figure.

**Table 6.13: USDG Data Mode**

<b>Item</b>	<b>Description</b>
Protocol	Click the drop-down menu to select the protocol: TCP or UDP.
Data Idle Timeout (s)	Enter a value to define the data idle timeout period.
Data Listen Port	Enter a value to identify the channel for remote initiating connections.
Telnet IAC	Enable Telnet IAC to allow USDG to support Telnet without producing garbled characters.
TCP User Timeout (s)	Enter a value for the TCP connection will wait before determining that a data transmission has failed due to a lack of acknowledgment.
Keepalive	If Disabled, the gateway assumes the host is always available. If Enabled, the following settings control the TCP Keep Alive function.
Keep Idle Time (s)	When no data is transmitted over this interval, initiate the Keep Alive function
Keep Interval (s)	When Keep Alive is activated, send a TCP Keep Alive message at the specified interval.
Keep Count	Disconnect with the host after the specified number of consecutive TCP Keep Alive requests fail to receive a response.
<b>Serial Scheduling</b>	
Response Timeout(s)	Enter a value to define the response timeout period.
<b>Serial RX Frame</b>	
Character Timeout	Enable or disable to send pack immediately by character-timeout.
End Character (HEX)	Click the option to send pack immediately by end-character.
Length	The length to request for Serial RX Frame
Break Time (ms)	Enter a value to specify the frame break time.
<b>Serial TX Frame</b>	
End Character (HEX)	Click the option to send pack immediately by end-character.
Length	The length to request for Serial RX Frame
Modbus RTU Command	Enable or disable sending Modbus RTU commands to a Modbus RTU end device, with data parsed according to the Modbus command format to ensure proper interpretation.
<b>Serial Data Forwarding</b>	
Serial RX Forwarding	Unicast or multicast data from the serial device to one or multiple host computers, and the serial device can also receive data from one or multiple host computers, making this mode ideal for message display applications.
Serial Token Idle Timeout(ms)	Enter a value for serial communication will wait without receiving any data or tokens before it considers the communication idle or inactive.
TX Broadcast	Enable or Disable TX Broadcast to transmit data from one device and broadcast it to multiple destinations or devices over a serial communication interface. Multicast: All devices in the network can see the data. Unicast: Only the devices connected to the PC can see the data.
<b>Transmit Target Peers</b>	
Peer Number	Click the drop-down menu to select the number of network device which you want to connect. Maximum is 16 network devices.

### 6.7.2.3 USDG Control Mode

The screenshot shows the 'Port 1 configuration' window in the 'Operation' tab. The 'Mode' dropdown is set to 'USDG Control Mode'. Below it, the 'Protocol' is set to 'TCP'. There are four input fields: 'Data Idle Timeout(s)' with the value '60', 'Data Listen Port' with the value '5300', 'Hangup Character' with the value '+', and 'Guard Time(ms)' with the value '1000'. A blue 'Save' button is located at the bottom center of the configuration area.

**Figure 6.17 Port Configuration > Operation > USDG Control Mode**

The following table describes the items in the previous figure.

**Table 6.14: USDG Control Mode**

Item	Description
Protocol	TCP protocol of the USDG control mode.
Data Idle Timeout (s)	Enter a value to define the data idle timeout period.
Data Listen Port	Enter a value to identify the channel for remote initiating connections.
Hang up Character	The default character is "+". After you have connected to another serial device via an EKI device, you may need to disconnect, using the command "+++". To do this, press "+" three times and wait for the idle timeout <default value is 100ms>; the device will disconnect. You can set "Guard Time" to define the idle time.
Guard Time (ms)	Enter a value to identify the guard time.

### 6.7.2.4 RFC2217 Mode

The screenshot shows the 'Port 1 configuration' window in the 'Operation' tab. The 'Mode' dropdown is set to 'RFC2217 Mode'. Below it, the 'Listen Port' is set to '5500' and the 'Host Idle Timeout(s)' is set to '1'. A blue 'Save' button is located at the bottom center of the configuration area.

**Figure 6.18 Port Configuration > Operation > RFC2217 Mode**

The following table describes the items in the previous figure.

**Table 6.15: RFC2217 Mode**

Item	Description
Listen Port	Enter a value to identify the channel for remote initiating connections.
Host Idle Timeout (s)	Enter a value to define the host idle timeout period.
Save	Click Save to save the values.

### 6.7.2.5 SSH Console Mode

If not configured, the account can only log in via HTTPS. If configured, it allows for permission management on the serial port.

LDAP, RADIUS, or local user authentication methods can be used for SSH logins.

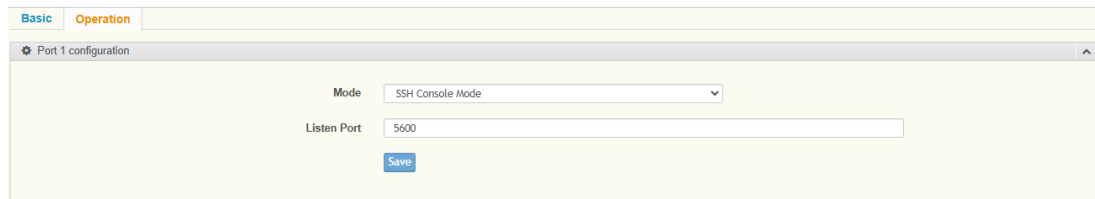

Figure 6.19 Port Configuration > Operation > SSH Console Mode

The following table describes the items in the previous figure.

Table 6.16: SSH Console Mode

Item	Description
Listen Port	In the Listen Port field, enter a value to bind the TCP port to the value. In the following figure a SSH client example is shown displaying the specified Port destination as configured in the Listen Port setting. To connect the EKI, the SSH client must also be configured to use TCP port 5600.
Save	Click Save to save the values.

## 6.8 Monitor

The EKI-1526 Series device server allows monitoring of the serial ports' status. The serial port's operation mode and status is available for display. The IP address of the host PC which is communicating with serial port is also displayed.

The Monitor function provides a method to monitor the serial device server's status (operation mode, baud rate, data bits, stop bits, parity and RTS/XON/DTR).

Monitoring information is divided into three main message types: Setting/Statistic/Connected IP.

### 6.8.1 Setting (VCOM 1.0)

The Monitor Setting page allows for easy viewing of the port's statistics. To access this page, click **Monitor > Setting**.

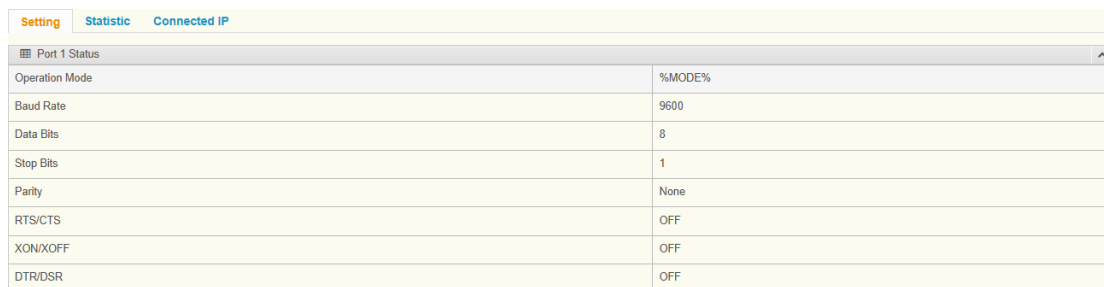

Port 1 Status	
Operation Mode	%MODE%
Baud Rate	9600
Data Bits	8
Stop Bits	1
Parity	None
RTS/CTS	OFF
XON/XOFF	OFF
DTR/DSR	OFF

Figure 6.20 Monitor > Setting

The following table describes the items in the previous figure.

Table 6.17: Setting (VCOM 1.0)	
Item	Description
Operation Mode	Display the current operation mode of the selected port.
Baud Rate	Display the current baud rate of the selected port.
Data Bits	Display the current data bits of the selected port.
Stop Bits	Display the current stop bits of the selected port.
Parity	Display the current parity of the selected port.
RTS/CTS	Display the current RTS/CTS status of the selected port.
XON/XOFF	Display the current XON/OFF status of the selected port.
DTR/DSR	Display the current DTR/DSR status of the selected port.

### 6.8.2 Statistic (VCOM 1.0)

The Monitor Statistic page allows for easy viewing of the port's TX/RX data count. To access this page, click **Monitor > Statistic**.

Port 1 Status	
Tx Count	0
Rx Count	0
Total Tx Count	0
Total Rx Count	0
RTS	OFF
CTS	ON
DTR	OFF
DSR	ON
DCD	ON

**Figure 6.21 Monitor > Statistic**

The following table describes the items in the previous figure.

Table 6.18: Statistic (VCOM 1.0)	
Item	Description
Tx Count	Display the current Tx count of the selected port.
Rx Count	Display the current Rx count of the selected port.
Total Tx Count	Display the current total Tx count of the selected port.
Total Rx Count	Display the current total Rx count of the selected port.
RTS	Display the current RTS status of the selected port.
CTS	Display the current CTS status of the selected port.
DTR	Display the current DTR status of the selected port.
DSR	Display the current DSR status of the selected port.
DCD	Display the current DCD status of the selected port.

### 6.8.3 Connected IP (VCOM 1.0)

The Monitor Connected IP page allows for easy viewing of all connected device's IP address.

To access this page, click **Monitor > Connected IP**.

Connected IP	IP Address
IP 1	
IP 2	
IP 3	
IP 4	
IP 5	
IP 6	
IP 7	
IP 8	
IP 9	
IP 10	
IP 11	
IP 12	
IP 13	
IP 14	
IP 15	
IP 16	

**Figure 6.22 Monitor > Connected IP**

The following table describes the items in the previous figure.

**Table 6.19: Connected IP (VCOM 1.0)**

Item	Description
Connected IP	Displays the IP designation for the device.
IP Address	Displays the current connected IP address of the selected port.

### 6.8.4 Status (VCOM 2.0)

VCOM Protocol Version 2.0 is chosen, information on the serial port function is presented in the Status section.

Information Name	Information Value
TX	0
RX	0
Modem	RTS DTR
Baud Rate	9600
Data Bits	8
Stop Bits	1
Parity	None
RTS/CTS	ON
XON/XOFF	OFF
DTR/DSR	OFF

**Figure 6.23 Monitor > Status**

The following table describes the items in the previous figure.

**Table 6.20: Status (VCOM 2.0)**

Item	Description
TX	Display the TX count of the selected port.
RX	Display the RX count of the selected port.
Modem	Display any active modem signals (RTS, CTS, DTR, DSR, DCD)
Baud Rate	Display the current baud rate of the selected port.
Data Bits	Display the current data bits of the selected port.
Stop Bits	Display the current stop bits of the selected port.
Parity	Display the current parity of the selected port.
RTS/CTS	Display the current RTS/CTS status of the selected port.
XON/XOFF	Display the current XON/OFF status of the selected port.
DTR/DSR	Display the current DTR/DSR status of the selected port.

### 6.8.5 VCOM Statistics (VCOM 2.0)

The maximum response time measurement is shown in the VCOM Statistics section of the page. You can check the actual maximum response time of the nodes, and adjust the timeout parameters accordingly.

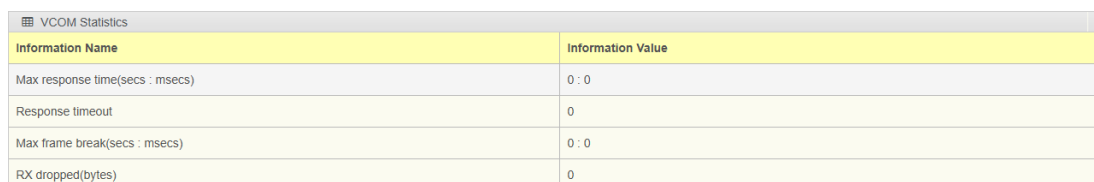

Information Name	Information Value
Max response time(secs : msecs)	0 : 0
Response timeout	0
Max frame break(secs : msecs)	0 : 0
RX dropped(bytes)	0

**Figure 6.24 Monitor > VCOM Statistics**

### 6.8.6 VCOM Clients (VCOM 2.0)

Display diagnostic information for VCOM clients, including addresses and connection start times.

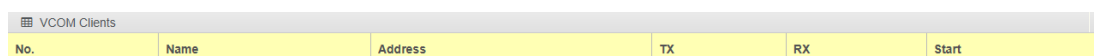

No.	Name	Address	TX	RX	Start
-----	------	---------	----	----	-------

**Figure 6.25 Monitor > VCOM Clients**

### 6.8.7 VCOM History (VCOM 2.0)

Display diagnostic information for connected VCOM clients, including addresses and connection start and end times.



No.	Address	TX	RX	Start	End
-----	---------	----	----	-------	-----

**Figure 6.26 Monitor > VCOM History**

## 6.8.8 Just-In-Time Diagnostics (VCOM 2.0)

The Just-In-Time (JIT) Diagnostics features of the device server assist in troubleshooting communication issues.

The JIT Event Analyzer allows for the dynamic insertion of multiple event trackers into a communication session at runtime for in-depth analysis, while JIT System Statistics continuously records data from each end device and TCP session, providing valuable insights for performance tuning and future audits. Additionally, the JIT Diagnostics feature helps resolve communication issues between the EKI network and downstream serial devices by enabling remote analysis and checking device status before disconnection.

JIT diagnostics can be enabled on Service > VCOM page, selecting VCOM 2.0, and saving your changes.

On the Syslogd > Syslogd Setting page, enable Syslogd and save your changes.

Reboot the device (Tools > Reboot) to apply the changes. JIT logs will then be displayed on the Syslogd > Syslogd Message page.

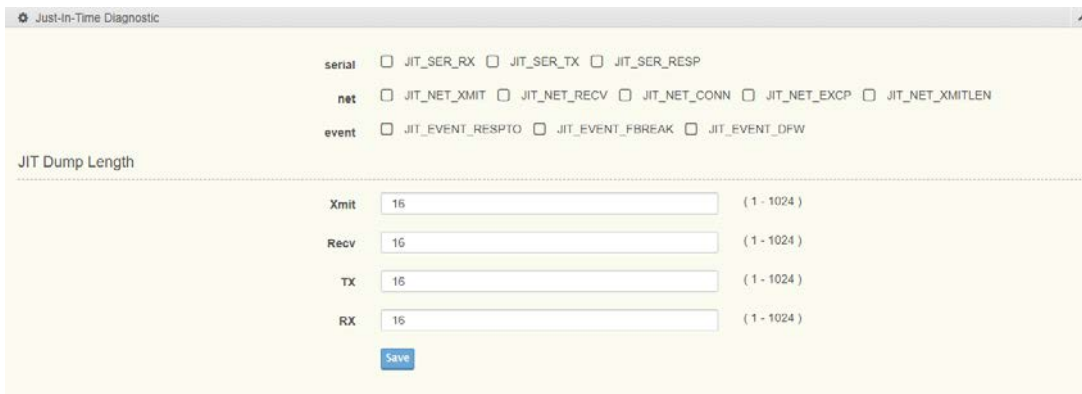

Figure 6.27 Monitor > Just-In-Time Diagnostics

## 6.9 Auto Warning (Alarm)

You can set the e-mail server and SNMP Trap server in the setting page, and set the event type in the Event page.

### 6.9.1 Setting

The Alarm Setting menu includes three alarm setting menus for event notification: Mail Sever, SNMP Trap Server, and the SNMP Agent Setting.

At the top of the list is the Mail Server setting which allows you to specify the mail server to be used by the serial device server in order to deliver notifications to selected Email accounts.

The SNMP Trap Server settings allows you to specify the management station of a significant event by way of an unsolicited SNMP message.

The Simple Network Management Protocol (SNMP) is used by the serial device server to collect detailed information about the serial device server. To access this page, click **Alarm > Setting**.

The screenshot shows the 'Alarm Setting' web interface. It is divided into three main sections:

- Mail Server:** Includes a 'Mail Server' text field, a 'From Email address' field (pre-filled with 'admin@advantech.com'), and four 'Email address' fields (1-4).
- SNMP Trap Server:** Includes a 'Trap Server' text field, a 'Trap Server Port' field (pre-filled with '162'), a 'Trap Version' section with radio buttons for 'v1' (selected), 'v2c', and 'v3', and a 'Trap Community' text field (pre-filled with 'public').
- SNMP Agent Setting:** Includes 'Read Community' and 'Write Community' text fields, 'SNMPv3 User Name' and 'SNMPv3 Password' text fields, 'SNMPv3 Authentication Type' with radio buttons for 'MD5' (selected) and 'SHA', 'SNMPv3 Privacy Type' with radio buttons for 'DES' (selected) and 'AES', and 'Contact' and 'Location' text fields.

A 'Save' button is located at the bottom of the form.

**Figure 6.28 Alarm > Setting**

The following table describes the items in the previous figure.

**Table 6.21: Setting**

Item	Description
<b>Mail Server</b>	
Mail Server	Enter the SMTP mail server.
From Email Address	Enter the email address.
Email Address 1	Enter the email address 1 to receive alarm emails.
Email Address 2	Enter the email address 2 to receive alarm emails.
Email Address 3	Enter the email address 3 to receive alarm emails.
Email Address 4	Enter the email address 4 to receive alarm emails.
<b>SNMP Trap Server</b>	
Trap Server	Enter the SNMP Trap server address.
Trap Server Port	Enter the SNMP Trap server port.
Trap Version	Click the radio button to select the SNMP version credentials: v1 or v2c or v3.
Trap Community	Enter the community string to be passed for the specified event.
<b>SNMP Agent Setting</b>	
Read Community	Enter the read-only, public, community string.
Write Community	Enter the write-only, private, community string.
SNMPv3 User Name	Enter the user's name for network search of SNMPv3.
SNMPv3 Password	Enter the password for network search of SNMPv3.
SNMPv3 Authentication Type	Select authentication based on the MD5 or SHA.

**Table 6.21: Setting**

SNMPv3 Privacy Type	Select data encryption type based on DES or AES.
Contact	Enter the individual designated the contact point for this event.
Location	Enter the designated location/department of the setting.
Save	Click Save to save the values and update the screen.

### 6.9.2 Event

The Alarm Event page allows the selection of triggers for system, DCD and DSR events for the alarm function.

To access this page, click **Alarm > Event**.

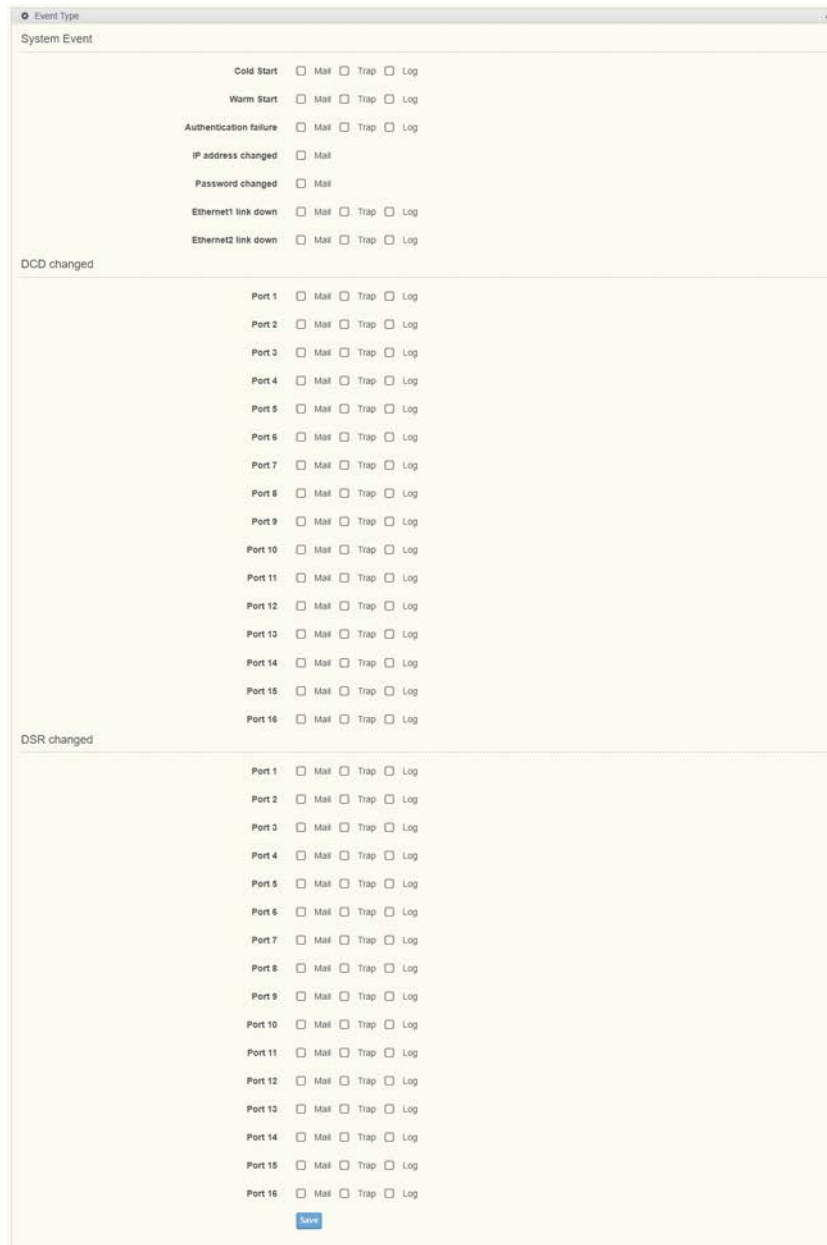

**Figure 6.29 Alarm > Event**

The following table describes the items in the previous figure.

Table 6.22: Event	
Item	Description
<b>System Event</b>	
Cold Start	Click the option to select a warning type when the device server's power is cut off and reconnected.
Warm Start	Click the option to select a warning type when the device server is reboot.
Authentication Failure	Click the option to select a warning type when an incorrect password is entered.
IP address Changed	Click the option to select a warning type when the IP address is changed.
Password Changed	Click the option to select a warning type when the password is changed.
Ethernet1 Link Down	Click the option to select a warning type when the Ethernet 1 port is disconnected.
Ethernet2 Link Down	Click the option to select a warning type when the Ethernet 2 port is disconnected.
<b>DCD Changed</b>	
Port	Click the option to select a warning type of the selected port when a change in the DCD (Data Carrier Detect) signal indicates that the modem connection status has changed.
<b>DSR Changed</b>	
Port	Click the option to select a warning type of the selected port when a change in the DSR (Data Set Ready) signal indicates that the data communication equipment is powered off.
Save	Click Save to save the values and update the screen.

## 6.10 Syslogd

The EKI-1526 Series device server provides the functionality to allow network devices to send event messages to a logging server, also known as a Syslog server, by way of the Syslogd function. The Syslog protocol is supported by a wide range of devices and can be used to log different types of events.

### 6.10.1 Syslogd Setting

Users can enable the syslogd function to record historical events or messages locally or on a remote syslog server.

To access this page, click **Syslogd > Syslogd Setting**.

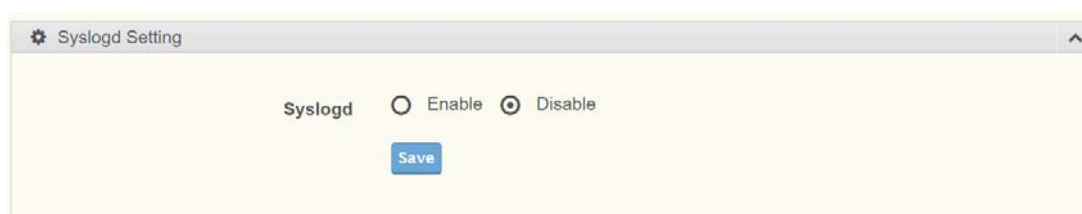

**Figure 6.30 Syslogd > Syslogd Setting**



**Figure 6.31 Syslogd > Syslogd Setting**

The following table describes the items in the previous figure.

Table 6.23: Syslogd Setting	
Item	Description
Syslogd	Click Enabled or Disabled to set the logging service status.
Syslogd Remote	Enable to send syslogd messages to a remote syslog server. Note that syslogd messages will not display in the local window when the remote feature is active.
Syslogd Remote IP Address	Enter Syslogd Remote IP address.
VCOM	Display syslog messages relay to VCOM 1.0 mode
USDG	Display syslog messages relay to USDG 1.0 mode
Save	Click Save to save the values and update the screen.

### 6.10.2 Syslogd Message

After enabling the syslogd function, users can check the history in the syslogd message page.

To access this page, click **Syslogd > Syslogd Message**.

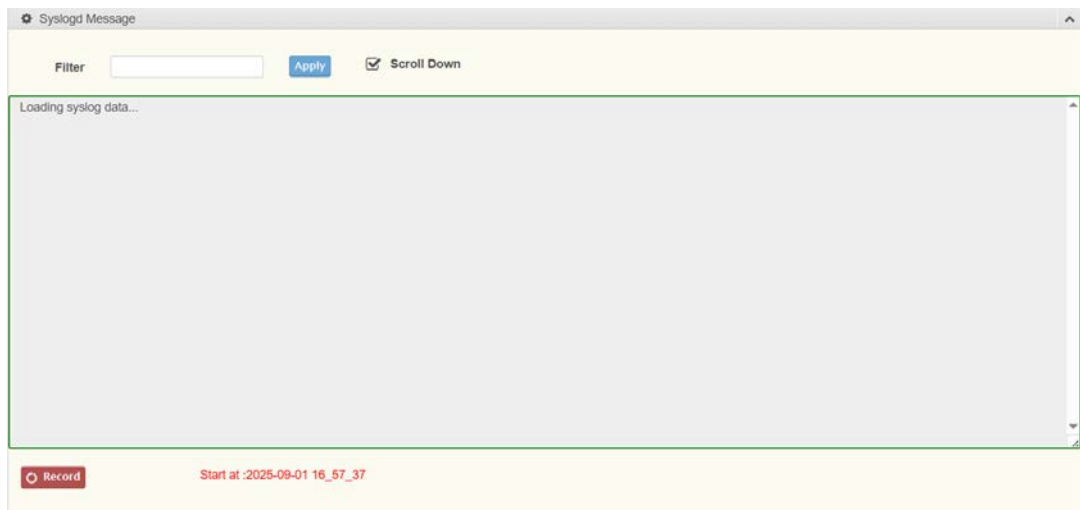

**Figure 6.32 Syslogd > Syslogd Message**

The message types selected on the Syslogd Setting page will be displayed. If Just-In-Time (JIT) Diagnostics are enabled, those messages will also appear here.

The Record function will create a temporary file in the browser to record the logs in the Syslogd Message window. Recording will continue until the button is clicked again, then the file will be downloaded to your PC as a text file.

### 6.10.3 VCOM Status

If the VCOM TLS handshake fails and the port cannot be identified, the error message will appear here.

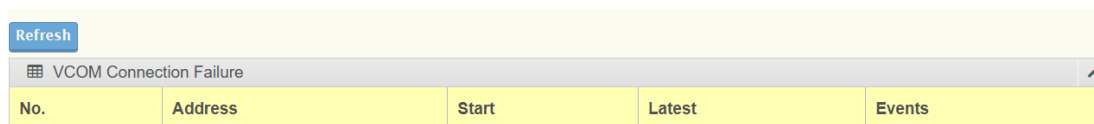

Figure 6.33 Syslogd > VCOM Status

## 6.11 Tools

The EKI-1526 Series device server provides tools for access to ping and reset functions.

### 6.11.1 Ping

The Ping page can help users diagnose Ethernet problems. Users can use the ping page to ask the device to ping a specific target to check the Ethernet network status. The Ping page allows you to configure the test log page. To access this page, click **Tools > Ping**.

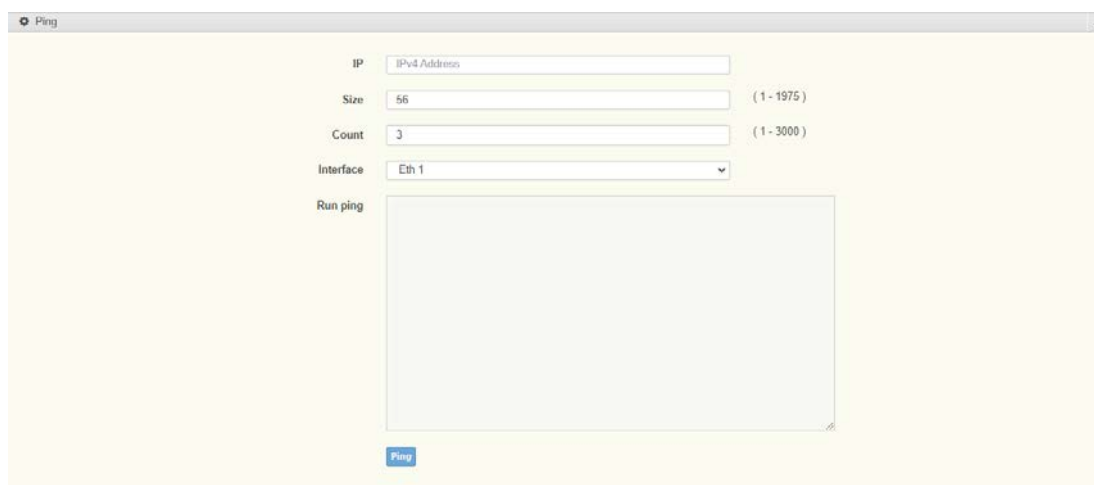

Figure 6.34 Tools > Ping

The following table describes the items in the previous figure.

Table 6.24: Ping	
Item	Description
IP	Enter the IP address or host name of the station to ping. The initial value is blank. The IP Address or host name you enter is not retained across a power cycle. Host names are composed of series of labels concatenated with periods. Each label must be between 1 and 63 characters long, maximum of 64 characters.

**Table 6.24: Ping**

Size	Enter the size of ping packet. The default value is 56. The value ranges from 8 to 5120. The size entered is not retained across a power cycle.
Count	Enter the number of echo requests to send. The default value is 4. The value ranges from 1 to 5. The count entered is not retained across a power cycle.
Interface	Select the Ethernet port to use for the ping.
Run ping	Display the ping reply format.

### 6.11.2 Certs Generator

All security-related functions require the corresponding certificate files to be imported into the device in order to properly enable **HTTPS**, **VCOM**, and **USDG** features.

Certificates can be generated in multiple ways:

Using EKI Utility (Tools > Create CA), on Windows OS, or using VCOM Driver on Linux OS or using the WebGUI Certs Generator page. Certs Generator page provides the ability to create certificates and deploy them with one click to the selected security functions.

To access this page, click **Tools > Certs Generator**.

1. Under Generate RootCA Cert and Download:

Fill in the required information.

Press the **Generate and Download** button.

A confirmation dialog will appear showing **Download Success** to verify that the file **x\_rootca.tar** has been successfully downloaded.

The screenshot shows the 'Certs Generator' web interface. At the top, there is a gear icon and the title 'Certs Generator'. Below that is an 'Action' dropdown menu currently set to 'Generate RootCA Certs and Download'. The main section is titled 'Generate TLS files' and contains several input fields for certificate information: 'Common Name(CN)\*' with the value 'adv\_icwg\_rootca', 'Country or Region(C)\*' with 'TW', 'Days Valid' with '365' (and a range '( 1 - 3650 )' to its right), 'State or Province(ST)' with 'e.g. Test State', 'Locality or City(L)' with 'e.g. Taipei', 'Organization(O)' with 'e.g. Advantech', 'Organizational Unit(OU)' with 'e.g. ICWG', and 'Email Address' with 'e.g. your\_email@example.com'. Below these fields are two buttons: 'Generate and Download' and 'Clear All'. The bottom section is titled 'Deploy Devices' and features a dropdown menu set to 'Deploy to Web Server' and a 'Deploy' button.

2. Generate Target Cert and Download

Fill in the required information.

Press the **Generate and Download** button.

A confirmation dialog will appear showing **Download Success** to verify that the file **x\_target.tar** has been successfully downloaded.

Click the **Deploy** button to quickly deploy the certificate to the corresponding function.

### 6.11.3 Reboot

The configuration will take effect after clicking Save button. All configurations are saved to flash memory after a system reboot. Press the Reboot button and the system will give a reset response. It will take a few seconds to reconnect with the new values.

To access this page, click **Tools > Reboot**.

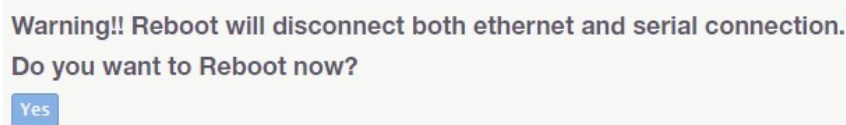

**Figure 6.35 Tools > Reboot**

Click **Yes** to reboot the serial device server. Any configuration changes you have made since the last time you saved will be lost.

## 6.12 Management

The EKI-1526 Series device server allows for easy installation and maintenance and reliable maintenance access from anywhere. With the reliable management tools available, you can streamline staffing and troubleshooting requirements to a centralized system.

### 6.12.1 Log File

If users enable the system event or serial event to log in file, users can download the log file from here.

To access this page, click **Management > Log File**.



**Figure 6.36 Management > Log File**

The following table describes the items in the previous figure.

**Table 6.25: Log File**

Item	Description
System Log File	Click the drop-down menu to select a specific action for the system log file. Available options: Download System Log, Remove System Log, Download and Remove System Log.
Export	Click Export to download the log file.

### 6.12.2 Change Password

The Change Password function allows you to easily update your current password from a single menu.

To access this page, click **Management > Change Password**.

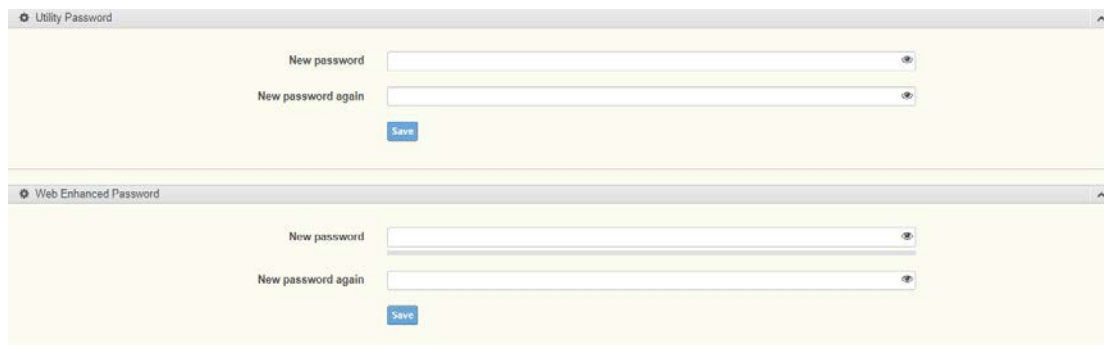

**Figure 6.37 Management > Change Password**

The following table describes the items in the previous figure.

**Table 6.26: Change Password**

Item	Description
<b>Utility Password</b>	
New Password	Enter the character set for the define password type.
New Password Again	Retype the password entry to confirm the profile password.
Save	Click Save to save the values and update the screen.
<b>Web Enhanced Password</b>	
New Password	Enter the character set for the define password type.
New Password Again	Retype the password entry to confirm the profile password.
Save	Click Save to save the values and update the screen.

If you have set a password, when you access the web configuration you need to key in the password. It is not necessary to enter the user name in the dialog. If you want to disable the password protection, change the password to the default option **None** (leave the new password column blank). Be sure to press the **Save** button and reboot the Modbus gateway to make the change effective.

**Note!** *If a password is set, a 20-minute session timer will start each time you log in to the web interface. To reset the timer before it expires, click the Session Timeout display at the top of the Web UI. When the session timer expires, you will be automatically logged out of the web interface.*



### 6.12.3 Secure access IP

To access this page, click Management > Secure access IP.



**Figure 6.38 Management > Secure access IP**

The following table describes the items in the previous figure.

**Table 6.27: Secure access IP**

Item	Description
Access IP Number	Enter a value to define access IP number
Save	Click Save to save the values and update the screen.

### 6.12.4 Export Device Settings

Export the server configuration settings to a .conf file.

To access this page, click **Management > Export**.

Click **Export** to export the serial device server settings.

### 6.12.5 Import Device Settings

Import the server configuration settings to a .conf file. To access this page, click **Management > Import**.

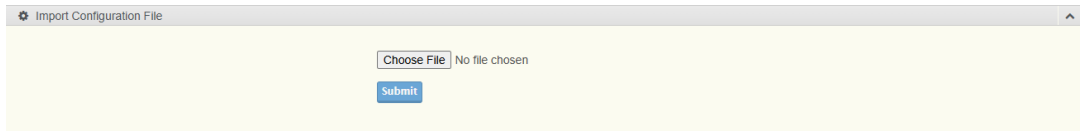

**Figure 6.39 Management > Import**

The following table describes the items in the previous figure.

**Table 6.28: Import Device Settings**

Item	Description
Choose File	Click Choose File to select the configuration file.
Submit	Click Submit to back up the settings.

### 6.12.6 Firmware Upgrade

RAUC enables a secure and reliable firmware upgrade mechanism.

1. Set the local time correctly

To access this page, click **System**.

Ensure the device system time is accurate to avoid certificate validation errors during the upgrade process.

2. Start the upgrade

Go to **Management > Firmware Upgrade** and Upload the firmware file.

Select the firmware bundle file (e.g., EKI-1526-D\_D1.36\_r7105.raucb).

Click **Upload** to transfer the file to the device.

Click the **Flash** button to initiate the upgrade process.



After the upgrade is completed successfully, the device will automatically reboot with the new firmware.

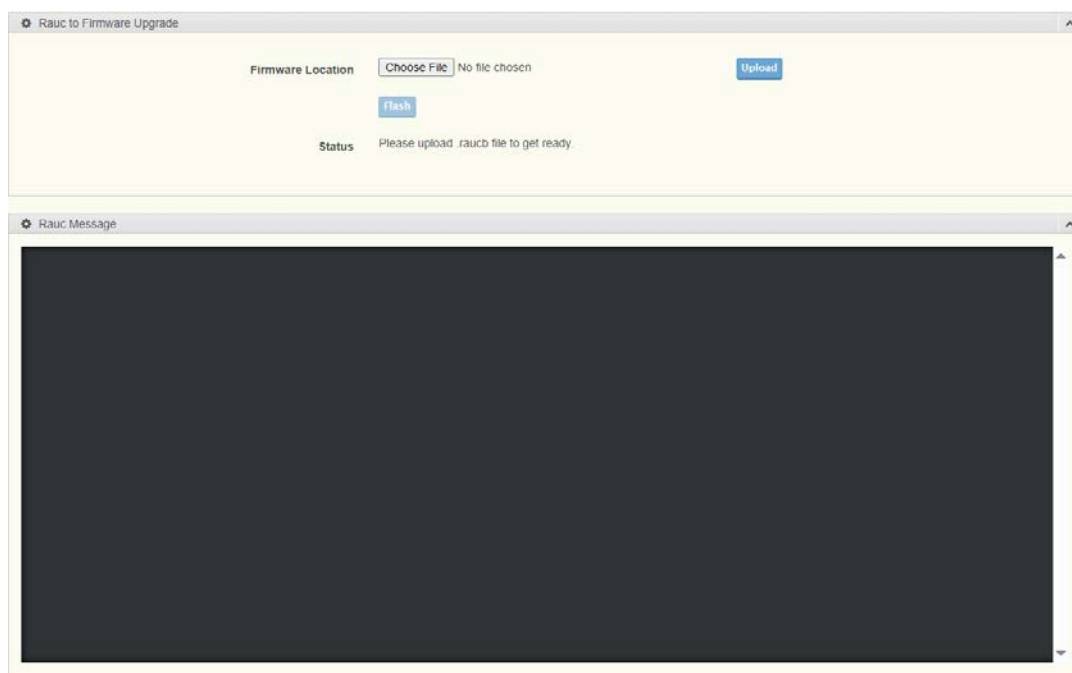

**Figure 6.40 Management > Firmware Upgrade**



# Chapter 7

Telnet and SSH

## 7.1 Overview

EKI-152x device server not only allows users to log in and configure the device via EKI Utility or Web GUI, but it also provides Telnet or SSH access to the EKI-152x, allowing users to view the device server through commands.

**Note!** *For security reasons, we recommend using SSH instead of Telnet. SSH (Secure Shell) is an encrypted network protocol that establishes a secure tunnel for network transmission, providing encrypted remote connections.*



## 7.2 Create a Telnet Connection

Enable the Telnet function in the EKI-152x Web GUI.

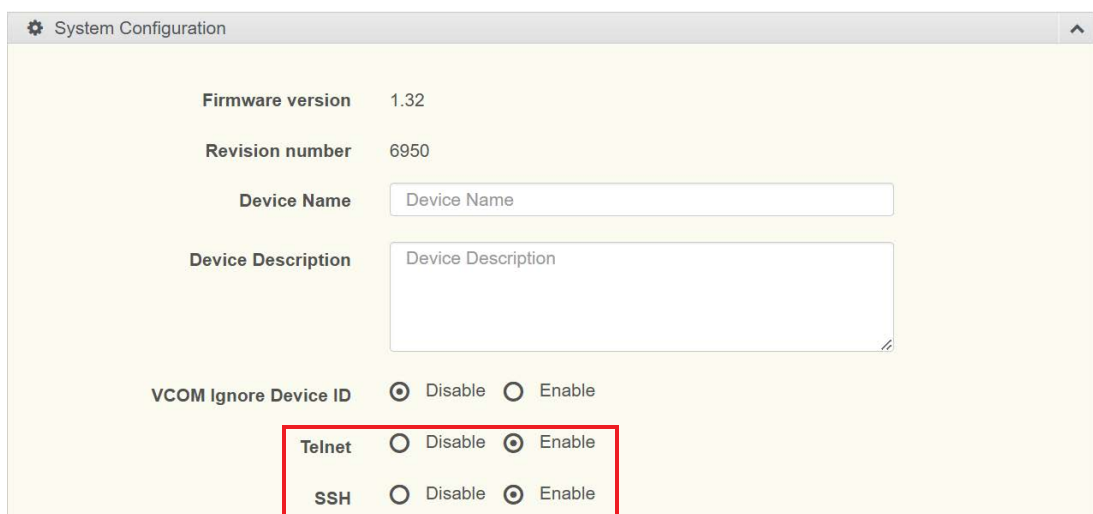
A screenshot of the 'System Configuration' web interface. The page has a light yellow background and a grey header with a gear icon and the text 'System Configuration'. The main content area contains several configuration fields: 'Firmware version' (1.32), 'Revision number' (6950), 'Device Name' (a text input field), and 'Device Description' (a larger text area). Below these are three radio button options: 'VCOM Ignore Device ID' (with 'Disable' selected), 'Telnet' (with 'Enable' selected), and 'SSH' (with 'Enable' selected). A red rectangular box highlights the 'Telnet' and 'SSH' options and their radio buttons.

**Figure 7.1 Enable Telnet or SSH Function**

Then, search for the "Command Prompt" application in your computer's search bar and open it.

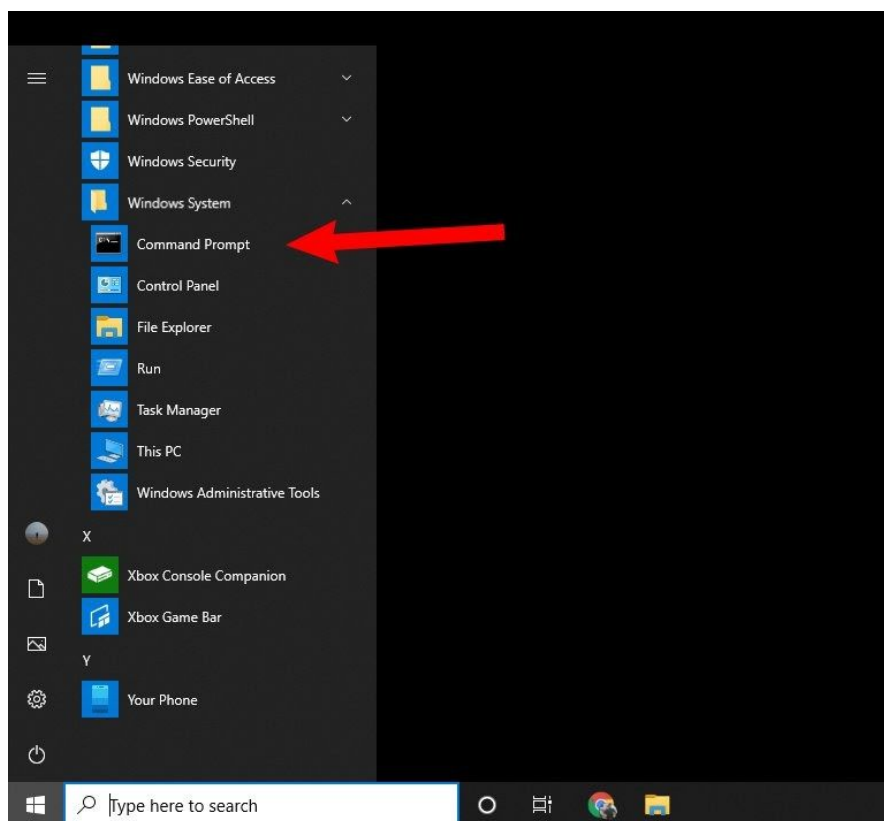

**Figure 7.2 Open the Command Prompt**

In the Command Prompt, type "telnet" followed by the EKI-152x device's local network IP address, and press Enter. For example, if the EKI-152x local network IP is 10.0.0.1, type "telnet 10.0.0.1" and press Enter.

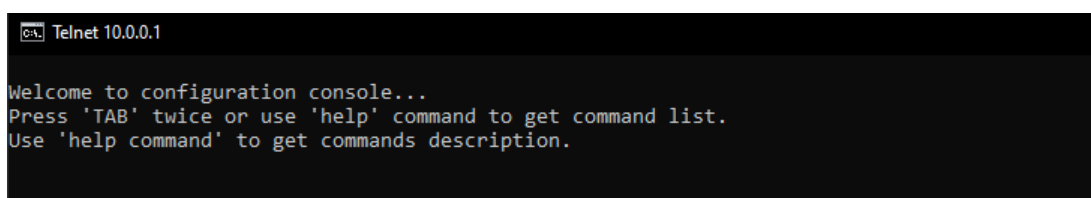

**Figure 7.3 Telnet Connection**

At the command prompt, you can type a "help" followed by the Enter button, or <Tab> twice, to display the command list. You can toggle between the different command menu options.

## 7.3 Serial Console

### 7.3.1 Connecting the cable

You can connect to the EKI-1526 serial device server's console port with a RS-232 DB9 M-type communication cable, with the other end connecting to the host's serial port. Make sure the connection is OK and then download and run the PuTTY on your host.

### 7.3.2 COM Port Settings

To connect the EKI-1526 device server for console configuration, the port setting should match the EKI-1526 device sever default settings.

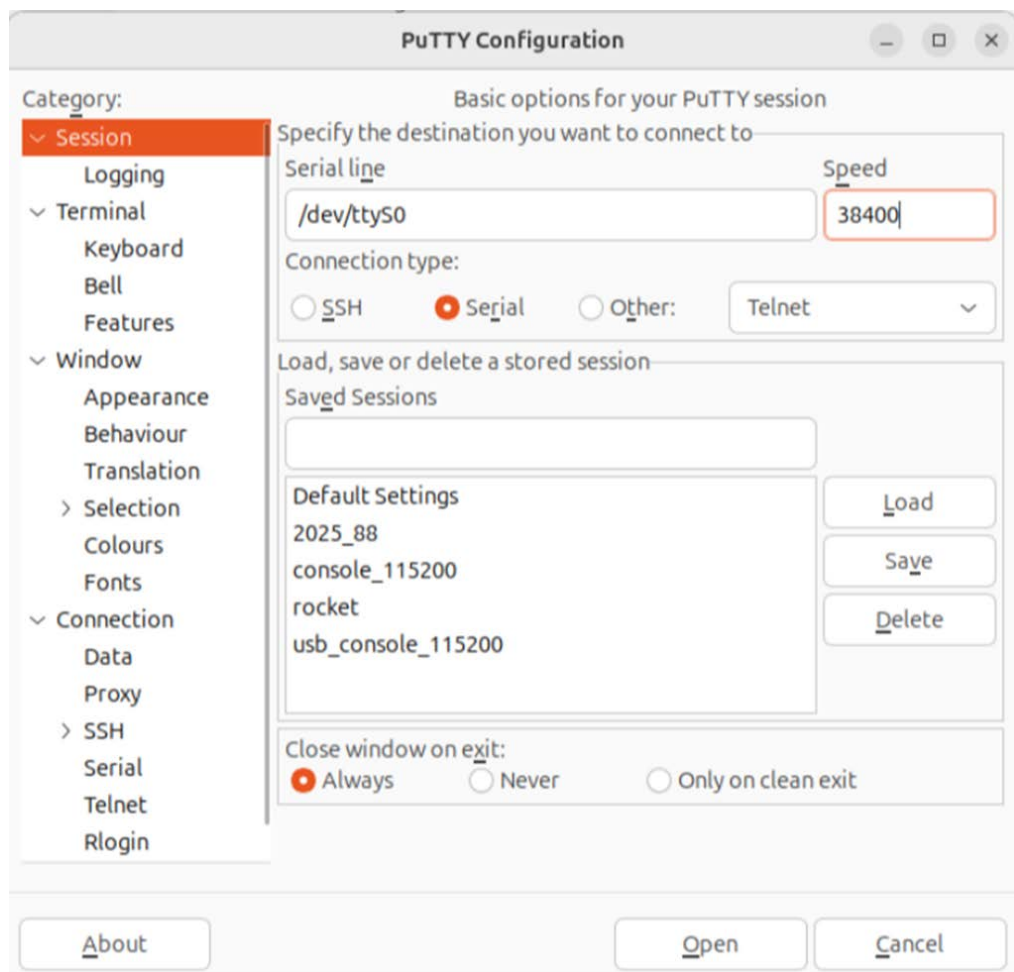

Figure 7.4 COM Port Settings

Console configuration default Settings:

- Serial line: “ \* ” of “ttyADV\*”
- Speed: 38400

## 7.4 Command List

**Table 7.1: Command List**

Command	Function Description
system	Show or configure the system information
port	Show or configure the serial ports information
portadv	Show or configure the serial ports advanced settings
mvcom	Show or configure the serial ports in Virtual COM mode
mctr	Show or configure the serial ports in Control mode (USDG)
mdata	Show or configure the serial ports in Data mode (USDG)
net	Show or configure the Ethernet ports settings
password	Set or change the password
alarm	Show or configure the auto warning functions including mail alarm and SNMP alarm
monitor	Monitor the serial ports status
mrfc2217	Show all port modes and mode information.
apply	Write settings to the flash memory and reboot the system immediately
exit	Terminate the shell session
help	Display command list help information
reboot	Write settings and reboot the system immediately.

### 7.4.1 System

Usage: system

Show current device status and informations.

Usage: system name [Maximum length 31 bytes]

Set current device name.

Usage: system desc [Maximum length 127 bytes]

Set current device description.

### 7.4.2 Port

Usage: port [nn|all]

Show port status and informations.

Usage: port [nn] desc [Maximum length 127 bytes]

Set serial port description.

Usage: port [nn|all] type [232|422|485] flow []

Set serial port type and flow control.

- flow 0:None.
- flow 1:XOn/XOff. – flow 2:RTS/CTS.
- flow 3:DTR/DSR.

Usage: port [nn|all] baud [50-921600] parity [] data [5-8] stop [1|1.5|2]

Set serial baud rate, parity and numbers of data bits, numbers of stop bits.

Acceptable baud: 50 75 110 150 300 600 1200 1800 2400 4800 7200 9600 14400 19200 38400 57600 115200 230400 460800 921600

- parity n: None Parity.
- parity e: Even Parity.

- parity o: Odd Parity.
  - parity m: Mark Parity.
  - parity s: Space Parity.
- Usage: port [nn|all] mode [vcom|ctrl|data]  
 Set serial port as virtual COM port or control mode or data mode.

### 7.4.3 Portadv

- \$ help portadv  
 Show port advanced setting.
- Usage: portadv [nn|all] delayT []  
 Set delay time(ms).
- Usage: portadv [nn|all] ignorepurge [TRUE|FALSE] dischato [TRUE|FALSE] dismulti-  
 con [TRUE|FALSE]  
 Enable or disable the feature of ignore purge.  
 Disable character timeout detection, and disable multiple connection.
- Usage: portadv [nn|all] databuf []  
 Set databuffer threshold.
- Usage: portadv [nn|all] timeout [] rtl [] ttl [] fcl [] fch []  
 Set port timeout, and set portrtl, portttl, portfcl, portfch.
- Usage: portadv [nn|all] fifosize [size|null]  
 Set port Writed size of FIFO, null for disable.
- Usage: portadv [nn|all] rts [] Set port RTS status.
- value 0: None Setting.
  - value 1: Setting power on.
  - value 2: Setting accept on.
  - value 4: Setting transmission on.
- Usage: portadv [nn|all] dtr [] Set port DTR status.
- value 0: None Setting.
  - value 1: Setting power on.
  - value 2: Setting accept on.
  - value 4: Setting transmission on.

### 7.4.4 Mvcom

- Usage: mvcom  
 Show all port mode and mode informations.
- Usage: mvcom [nn|all]  
 Set port [nn|all] as virtual COM port mode.
- Usage: mvcom [nn|all] idleto []  
 Set host idle timeout(s).
- Usage: mvcom [nn|all] respto [] framebk []  
 Set response timeout(ms) and frame break(ms).
- Usage: mvcom [nn|all] bysize []
- Usage: mvcom [nn|all] bytime []
- Usage: mvcom [nn|all] bychar [NULL|]  
 Set datapackage as size(bytes) or time(ms) and character(HEX) .
- value 0: None Setting.

### 7.4.5 Mctrl

Usage: mctrl

Show port mode and mode informations.

Usage: mctrl [nn|all]

Set port [nn|all] as control mode.

Usage: mctrl [nn|all] idleto [] tcpp [] atp [] guardt [] hangchr []

Set data idle timeout(s) data listen port command listen port guard time(ms)  
hangup character.

### 7.4.6 Mdata

Usage: mdata

Show port mode and mode informations.

Usage: mdata [nn|all]

Set port [nn|all] as data mode.

Usage: mdata [nn|all] protocol [TCP|UDP]

Set transmit protocol as TCP or UDP.

Usage: mdata [nn|all] idleto [] lsport [] atport []

Set data idle timeout(s) listen port and AT command port.

Usage: mdata [nn|all] respto [] framebk []

Set response timeout(ms) and frame break(ms).

Usage: mdata [nn|all] bysize [] bytime [] bychar [NULL] bychartimeout [ON|OFF]

Set datapackage as size(bytes) or time(ms) or character(HEX) and character-timeout.

– value 0: None Setting.

Usage: mdata [nn|all] autopeerip [ON|OFF]

Set auto connect to peer ip as on or off.

Usage: mdata [nn|all] peernum [1-16] peer [d.d.d.d:d] ...

Set peer IP address and port for receive data.

### 7.4.7 Net

Usage: net [1|2]

Show device network status and informations.

Usage: net [1|2] mode [static|dhcp|bootp|all]

Set network operating mode.

Usage: net [1|2] ip [d.d.d.d] netmask [d.d.d.d] gw [d.d.d.d]

Set IP address and subnet mask and gateway.

Usage: net [1|2] dns [auto|specific]

Enable/Disable DNS.

Usage: net [1|2] dns1 [d.d.d.d]

Set network DNS1.

Usage: net [1|2] dns2 [d.d.d.d]

Set network DNS2.

Usage: net [1|2] to [d]

Set network timeout.

---

## 7.4.8 Password

Usage: password

Display two different Usage.

Usage: password new [1-31 characters]

Set new password.

Usage: password old [\*\*...] new [1-31 characters]

Confirm the old password and set new password.

## 7.4.9 Alarm

Usage: alarm

Show current alarm informations.

Usage: alarm mail server [null|address] from [null|address] to1 [null|address] to2 [null|address] to3 [null|address] to4 [null|address]

Set current mail server configuration.

Usage: alarm trap server [null|address] ver [1|2] community [null|name]

Set current trap server configuration.

Usage: alarm agent rcommunity [null|name] wcommunity [null|name] contact ull|name] location [null|name]

Set current snmp agent configuration.

Usage: alarm event mail [cstart] [wstart] [auth] [ip] [passwd] [eth1] [eth2]

Set current mail event configuration.

Usage: alarm event trap [cstart] [wstart] [auth] [eth1] [eth2]

Set current trap event configuration.

Usage: alarm port [1|2|..] dcd [none|mail|trap|all] dsr [none|mail|trap|all]

Set current port alarm configuration.

## 7.4.10 Monitor

Usage: monitor port [1|2|..] setting Monitor COM port setting

Usage: monitor port [1|2|..] statistic

Monitor COM port statistic data

Usage: monitor port [1|2|..] ip Monitor connected IP

## 7.4.11 Time

Usage: time

Show current time informations.

Usage: time [YYYYMMDDhhmmss]

Set current time configuration.

Usage: time ntp [timeserver]

Set current time server configuration.

## 7.4.12 Service

Usage: service telnet [enable|disable] Enable/Disable telnet function

Usage: service snmp [enable|disable] Enable/Disable SNMP function

## 7.4.13 Mrfc2217

Usage: mrfc2217

Show all port mode and mode informations.

Usage: mrfc2217 [nn|all]

Set port [nn|all] as RFC2217 mode.

Usage: mrfc2217 [nn|all] idleto [] lsport []

Set host idle timeout(s) and listen port.

#### 7.4.14 Apply

Usage: apply

Save the settings to flash and reboot right now.

#### 7.4.15 Exit

Usage: exit

Terminate shell session

#### 7.4.16 Help

Usage: help [cmd]

Display help information of command cmd

#### 7.4.17 Reboot

Usage: reboot

Write settings and reboot the system immediately.



# Chapter 8

TCP and UDP Port

## 8.1 List of Known TCP and UDP Port Numbers

**Table 8.1: List of Known TCP and UDP Port Numbers**

<b>Port</b>	<b>Protocol</b>	<b>Service</b>
5048	(TCP/UDP)	Configuration Utility
5058	(TCP/UDP)	Configuration Utility
5202	(TDP)	VCOM/RVCOM
9999	(TDP)	Firmware Download
22	(TDP)	SSH
23	(TDP)	Telnet
25	(TDP)	SMTP (Mail Client)
53	(TCP/UDP)	DNS
67	(UDP)	BOOTP Server/DHCP
68	(UDP)	BOOTP Client/DHCP
80	(TDP)	Web Interface/HTTP
123	(TDP)	NTP
161	(TDP)	SNMP
162	(TCP/UDP)	SNMP Trap
443	(TDP)	HTTPS
502	(TDP)	Modbus/TCP (Default)
514	(TDP)	Syslog
546	(TCP/UDP)	DHCPv6 Client
547	(TCP/UDP)	DHCPv6 Server



## [www.advantech.com](http://www.advantech.com)

Please verify specifications before quoting. This guide is intended for reference purposes only.

All product specifications are subject to change without notice.

No part of this publication may be reproduced in any form or by any means, such as electronically, by photocopying, recording, or otherwise, without prior written permission from the publisher.

All brand and product names are trademarks or registered trademarks of their respective companies.

© Advantech Co., Ltd. 2025