

User Manual

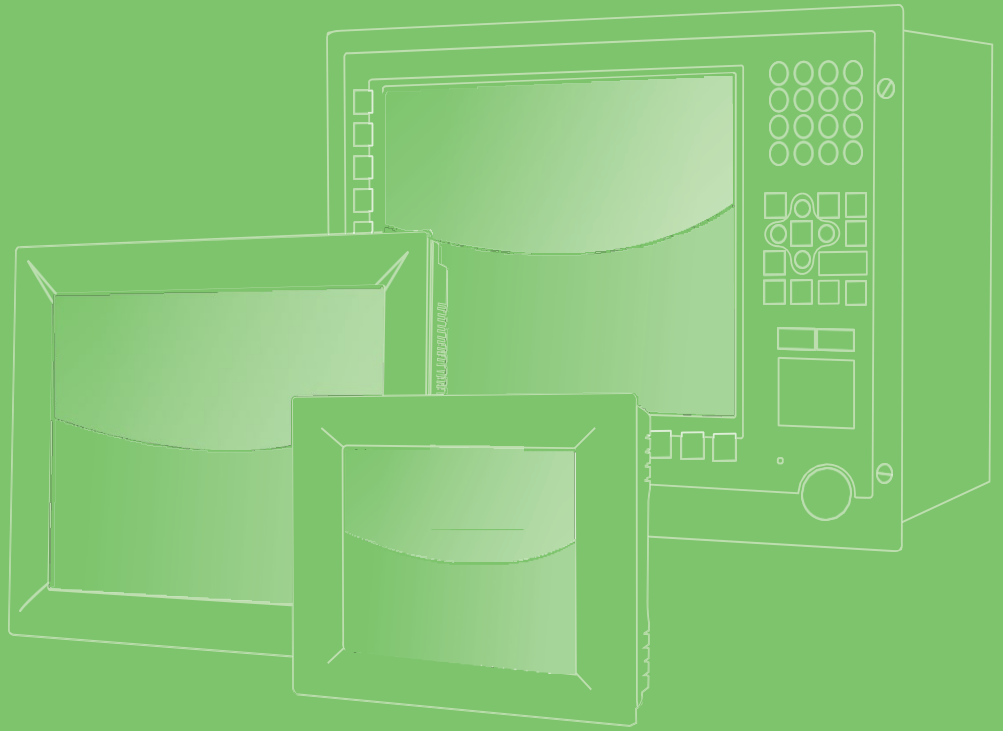

TPC-307W

7" Touch Panel Computer

製造商: 研華股份有限公司

地址: 台北市內湖區陽光街365巷33號

電話: 02-27927818

ADVANTECH

Enabling an Intelligent Planet

Copyright

The documentation and the software included with this product are copyrighted 2025 by Advantech Co., Ltd. All rights are reserved. Advantech Co., Ltd. reserves the right to make improvements in the products described in this manual at any time without notice. No part of this manual may be reproduced, copied, translated or transmitted in any form or by any means without the prior written permission of Advantech Co., Ltd. Information provided in this manual is intended to be accurate and reliable. However, Advantech Co., Ltd. assumes no responsibility for its use, nor for any infringements of the rights of third parties, which may result from its use.

Acknowledgements

Intel and Atom are trademarks of Intel Corporation.
Microsoft Windows and MS-DOS are registered trademarks of Microsoft Corp.
All other product names or trademarks are properties of their respective owners.

This manual is applicable to the following models:

TPC-307W series

- TPC-307W-PE20A

Part No.	Edition 1
Printed in Taiwan	August 2025

Product Warranty (2 years)

Advantech warrants to you, the original purchaser, that each of its products will be free from defects in materials and workmanship for two years from the date of purchase.

This warranty does not apply to any products which have been repaired or altered by persons other than repair personnel authorized by Advantech, or which have been subject to misuse, abuse, accident or improper installation. Advantech assumes no liability under the terms of this warranty as a consequence of such events.

Because of Advantech's high quality-control standards and rigorous testing, most of our customers never need to use our repair service. If an Advantech product is defective, it will be repaired or replaced at no charge during the warranty period. For out-of-warranty repairs, you will be billed according to the cost of replacement materials, service time and freight. Please consult your dealer for more details.

If you think you have a defective product, follow these steps:

1. Collect all the information about the problem encountered. (For example, CPU speed, Advantech products used, other hardware and software used, etc.) Note anything abnormal and list any onscreen messages you get when the problem occurs.
2. Call your dealer and describe the problem. Please have your manual, product, and any helpful information readily available.
3. If your product is diagnosed as defective, obtain an RMA (return merchandise authorization) number from your dealer. This allows us to process your return more quickly.
4. Carefully pack the defective product, a fully-completed Repair and Replacement Order Card and a photocopy proof of purchase date (such as your sales receipt) in a shippable container. A product returned without proof of the purchase date is not eligible for warranty service.
5. Write the RMA number visibly on the outside of the package and ship it prepaid to your dealer.

Declaration of Conformity

CE

This product has passed the CE test for environmental specifications when shielded cables are used for external wiring. We recommend the use of shielded cables. This type of cable is available from Advantech. Please contact your local supplier for ordering information.

FCC Class A

Note: This equipment has been tested and found to comply with the limits for a Class A digital device, pursuant to part 15 of the FCC Rules. These limits are designed to provide reasonable protection against harmful interference when the equipment is operated in a commercial environment. This equipment generates, uses, and can radiate radio frequency energy and, if not installed and used in accordance with the instruction manual, may cause harmful interference to radio communications. Operation of this equipment in a residential area is likely to cause harmful interference in which case the user will be required to correct the interference at his own expense.

甲類資訊技術設備

警告：為避免電磁干擾，本產品不應安裝或使用於住宅環境。

A 級产品

警告：在居住环境中，运行此设备可能会造成无线电干扰。

Technical Support and Assistance

1. Visit the Advantech web site at www.advantech.com/support where you can find the latest information about the product.
2. Contact your distributor, sales representative, or Advantech's customer service center for technical support if you need additional assistance. Please have the following information ready before you call:
 - Product name and serial number
 - Description of your peripheral attachments
 - Description of your software (operating system, version, application software, etc.)
 - A complete description of the problem
 - The exact wording of any error messages

Warnings, Cautions and Notes

Warning! Warnings indicate conditions, which if not observed, can cause personal injury!



Les avertissements indiquent des conditions qui, si elles ne sont pas respectées, peuvent provoquer des blessures !

Caution! Cautions are included to help you avoid damaging hardware or losing data. e.g.



There is a danger of a new battery exploding if it is incorrectly installed. Do not attempt to recharge, force open, or heat the battery. Replace the battery only with the same or equivalent type recommended by the manufacturer. Discard used batteries according to the manufacturer's instructions.

Des précautions sont incluses pour vous aider à éviter d'endommager le matériel ou de perdre des données. par exemple.

Il existe un risque d'explosion d'une nouvelle batterie si elle n'est pas correctement installée. N'essayez pas de recharger, d'ouvrir de force ou de chauffer la batterie. Remplacez la batterie uniquement par une pile identique ou équivalente recommandée par le fabricant. Jetez les piles usagées conformément aux instructions du fabricant.

Note! Notes provide optional additional information.



Safety Instructions

1. Read these safety instructions carefully.
2. Keep this User Manual for later reference.
3. Disconnect this equipment from any AC outlet before cleaning. Use a damp cloth. Do not use liquid or spray detergents for cleaning.
4. For plug-in equipment, the power outlet socket must be located near the equipment and must be easily accessible.
5. Keep this equipment away from humidity.
6. Put this equipment on a reliable surface during installation. Dropping it or letting it fall may cause damage.
7. The openings on the enclosure are for air convection. Protect the equipment from overheating. **DO NOT COVER THE OPENINGS.**
8. Make sure the voltage of the power source is correct before connecting the equipment to the power outlet. By means of a power cord connected to a socket-outlet with earthing connection.
9. Position the power cord so that people cannot step on it. Do not place anything over the power cord.
10. All cautions and warnings on the equipment should be noted.
11. If the equipment is not used for a long time, disconnect it from the power source to avoid damage by transient overvoltage.
12. Never pour any liquid into an opening. This may cause fire or electrical shock.
13. Never open the equipment. For safety reasons, the equipment should be opened only by qualified service personnel.
14. If one of the following situations arises, get the equipment checked by service personnel:
 - a. The power cord or plug is damaged.
 - b. Liquid has penetrated into the equipment.
 - c. The equipment has been exposed to moisture.
 - d. The equipment does not work well, or you cannot get it to work according to the user's manual.
 - e. The equipment has been dropped and damaged.
 - f. The equipment has obvious signs of breakage.
15. Do not leave this equipment in an environment where the storage temperature may fluctuate below $-20\text{ }^{\circ}\text{C}$ ($-4\text{ }^{\circ}\text{F}$) or above $60\text{ }^{\circ}\text{C}$ ($140\text{ }^{\circ}\text{F}$).
16. **DANGER OF EXPLOSION IF BATTERY IS INCORRECTLY REPLACED. REPLACE ONLY WITH THE SAME OR EQUIVALENT TYPE RECOMMENDED BY THE MANUFACTURER, DISCARD USED BATTERIES ACCORDING TO THE MANUFACTURER'S INSTRUCTIONS.**
17. In accordance with the IEC 704-1:1982 specifications, the sound pressure level at the operator position does not exceed 70 dB (A).
18. **DISCLAIMER:** These instructions are provided according to IEC 704-1. Advantech disclaims all responsibility for the accuracy of any statements contained herein.
19. This product is not intended for use by children (this product is not a toy).
20. This equipment is not suitable for use in locations where children are likely to be present.
21. The wire of the protective bonding conductor shall be green-and-yellow, 22AWG/0.3mm² minimum.
22. This product is intended to be supplied by a UL listed (Certificate) power supply with a mating connector, output rated 24Vdc, 2.5A, Tma 60 degree C minimum and altitude 2000m. If need further assistance, please contact manufacture or UL File owner or brand owner for additional information.

安全指示

1. 請仔細閱讀此安全操作說明。
2. 請妥善保存此用戶手冊供日後參考。
3. 用濕抹布清洗設備前，請從插座拔下電源線。請不要使用液體或去汙噴霧劑清洗設備。
4. 對於使用電源線的設備，設備周圍必須有容易接觸到的電源插座。
5. 請不要在潮濕環境中使用設備。
6. 請在安裝前確保設備放置在可靠的平面上，意外跌落可能會導致設備損壞。
7. 設備外殼的開口是用於空氣對流，從而防止設備過熱。請不要覆蓋這些開口。
8. 當您連接設備到電源插座上前，請確認電源插座的電壓是否符合要求。
9. 請將電源線佈置在人們不易絆到的位置，並不要在電源線上覆蓋任何雜物。
10. 請注意設備上的所有警告和注意標示。
11. 如果長時間不使用設備，請將其同電源插座斷開，避免設備被超標的電壓波動損壞。
12. 請不要讓任何液體流入通風口，以免引起火災或者短路。
13. 請不要自行打開設備。為了確保您的安全，請由經過認證的工程師來打開設備。
14. 如遇下列情況，請由專業人員來維修：
 - 電源線或者插頭損壞；
 - 設備內部有液體流入；
 - 設備曾暴露在過於潮濕的環境中使用；
 - 設備無法正常工作，或您無法通過用戶手冊來使其正常工作；
 - 設備跌落或者損壞；
 - 設備有明顯的外觀破損。
15. 請不要把設備保存在超出我們建議的溫度範圍的環境，即不要低於 -20°C (-4°F) 或高於 60°C (140°F)，否則可能會損壞設備。
16. 注意：如果電池放置不正確，將有爆炸的危險。因此，只可以使用製造商推薦的同一種或者同等型號的電池進行替換。請按照製造商的指示處理舊電池。
17. 根據 IEC 704-1:1982 的規定，操作員所在位置的音量不可高於 70dB(A)。
18. 限制區域：請勿將設備安裝於限制區域使用。
19. 免責聲明：該安全指示符合 IEC 704-1 的要求。研華公司對其內容的準確性不承擔任何法律責任。
20. 使用過度恐傷害視力。
21. 使用 30 分鐘請休息 10 分鐘。
22. 未滿 2 歲幼兒不看螢幕，2 歲以上每天看螢幕不要超過 1 小時。
23. 本產品為國內裝置使用時，其電源僅限使用架構電源模組所提供電源直流輸入，不得使用交流電源及附加其他電源轉換裝置提供電源這者，其電源輸入電壓及電流請依說明書規定使用。
24. 本產品由帶有對接連接器的 UL 認證電源供電，額定輸出為 24Vdc, 2.5A, Tma 最低溫度為攝氏 60 度，海拔高度為 2000m。如果需要進一步協助，請聯絡製造商或 UL 文件所有者或品牌所有者以獲取更多資訊。

Safety Precaution - Static Electricity

For Skilled person follow these simple precautions to protect yourself from harm and the products from damage.

- To avoid electrical shock, always disconnect the power from your PC chassis before you work on it. Don't touch any components on the CPU card or other cards while the PC is on.
- Disconnect power before making any configuration changes. The sudden rush of power as you connect a jumper or install a card may damage sensitive electronic components.

Content

Chapter 1	General Information	1
1.1	Introduction	2
1.2	Specifications	2
1.2.1	General	2
1.2.2	System Kernel	2
1.2.3	Communication Interface	2
1.2.4	LCD Panel	3
1.2.5	Touchscreen	3
1.2.6	Environment	3
1.2.7	EMC and Safety	3
1.2.8	Power	3
1.2.9	External I/O	3
1.3	Dimensions and Cutout	4
Chapter 2	Installation	5
2.1	Transport and Unpacking	6
2.1.1	Transport	6
2.1.2	Unpacking	6
	Figure 2.1 Power Connector and Power Lines	6
	Figure 2.2 Power Connector	7
	Figure 2.3 Power LED	7
2.2	Panel Mount	8
	Figure 2.4 Panel Mounting – Positioning	8
	Figure 2.5 Panel Mounting – Clamp with Screw	8
	Figure 2.6 Panel Mounting – Clamp Fixing	9
2.3	VESA Mount	9
	Figure 2.7 VESA Mounting	9
2.4	Cabinet Installation and Earth Grounding Setup	10
2.4.1	Installing TPC into Cabinet	10
	Figure 2.8 Cabinet Installation	10
2.4.2	System Wiring	10
2.5	System Configuration	11
2.5.1	Rear Bracket Removal	11
2.5.2	AT/ATX Jumper Setting (PSON1)	12
	Table 2.1: AT/ATX Function	12
2.5.3	Enabling Wake On Touch	13

Appendix A Connectors14

A.1	Jumper and Connector Location	15
A.1.1	Board Layout.....	15
	Figure A.1 Board Layout - Top View	15
	Table A.1: Connector and Jumpers	15
A.2	Jumper Settings and Descriptions.....	16
A.2.1	CMOS Clear Function (JCMOS1).....	16
	Table A.2: CMOS Clear Function	16
A.2.2	LCD Resolution Select (SW1).....	16
	Table A.3: LCD Resolution Select	16
A.3	Connector Pin Definition.....	17
A.3.1	Power Button Connector (BTN1)	17
	Table A.4:Power Button Connector (BTN1)	17
A.3.2	Internal USB Connector (USB2H1 & USB2H2).....	17
	Table A.5: Internal USB Connector (USB2H1 & USB2H2)	17
A.3.3	LED Indicator Connector (LED2)	17
	Table A.6: LED Indicator Connector (LED2)	17
A.3.4	RTC Battery Connector (BAT1).....	18
	Table A.7: RTC Battery Connector (BAT1)	18
A.3.5	COM1 RS-232 Connector (COM1).....	18
	Table A.8: Internal COM Port Connector (COM1)	18
A.3.6	COM2 RS-232/422/485 Connector (COM2).....	19
	Table A.9: COM2 RS-232/422/485 Connector (COM2)	19
A.3.7	Power Input Connector (DCIN1).....	19
	Table A.10: Power Input Connector (DCIN1)	19

Appendix B BIOS Setup.....20

B.1	Entering Setup.....	21
B.2	Main Setup	22
B.3	Advanced BIOS Features Setup	23
B.3.1	CPU Configuration	24
B.3.2	Power & Performance	25
B.3.3	PCH-FW Configuration	26
B.3.4	Trusted Computing.....	27
B.3.5	ACPI Settings.....	28
B.3.6	NCT61260 Super IO Configuration.....	29
B.3.7	NCT61260 HW Monitor.....	30
B.3.8	USB Configuration	31
B.3.9	Network Stack Configuration	32
B.3.10	NVMe Configuration.....	33
B.4	Chipset Configuration	34

B.4.1	System Agent (SA) Configuration	34
B.4.2	PCH-IO Configuration	35
B.5	Security.....	36
B.6	Boot	37
B.7	Save & Exit.....	38

Chapter 1

General Information

1.1 Introduction

The TPC-307W Elkhart Lake series touch panel computer is a human machine interface (HMI) equipped with an Intel® Atom™ X6211E dual core processor.

- Industrial-grade 7" WSVGA TFT LCD with 50K lifetime and LED backlight
- Fanless design
- Intel® Elkhart Lake (EHL) Atom™ X6211E 1.30 GHz, dual core processor
- Compact, fanless embedded system with aluminum alloy front bezel
- Wide operating temperature range -20 ~ 60 °C (-4 ~ 140 °F)
- True-flat, IP66-rated front panel
- True-flat touchscreen with P-CAP multi-touch control
- Supports AC/DC input with optional power adapter
- Chassis grounding protection

1.2 Specifications

1.2.1 General

- **BIOS:** AMI UEFI
- **Cooling System:** Fanless design
- **Dimensions (W x H x D):** 205 x 146.92 x 55.7mm (8.07 x 5.78 x 2.20 inch)
- **Weight (Net):** 1.5 kg (3.3 lb)
- **Enclosure:**
 - Front bezel: Die cast aluminum alloy
 - Back housing: SECC
- **Mounting:** VESA mount (75 x 75), panel, wall
- **OS Support:** Windows 10 Enterprise LTSB

1.2.2 System Kernel

- **CPU:**
 - Intel® Elkhart Lake (EHL) Atom™ X6211E 1.30 GHz, dual core
- **Memory:**
 - 1 x DDR4 SO-DIMM (up to 16GB)
- **Watchdog Timer:** Programmable as 1 ~ 255 second

1.2.3 Communication Interface

- **Serial Port:**
 - 1 x RS-232 (COM 1)
 - 1 x RS-232/422/485 (COM 2)
- **LAN Port:** 2 x 10/100/1000BASE-T RJ45 LAN
- **Expansion Slots:** 1 x M.2 E Key 2230 (USB/PCIe)
- **Storage Slots:** 1 x M.2 M Key 2242/2280 (SATA/PCIe)
- **Others:**
 - 2 x USB 3.0 Type-A
 - 2 x USB 2.0 Type-A
 - 1 x Line out

1.2.4 LCD Panel

- **Display Type:** WSGA TFT LED LCD
- **Display Size:** 7"
- **Max. Resolution:** 1024 x 600
- **Max. Colors:** 16.7M
- **Luminance (cd/m²):** 500
- **Viewing Angle (H/V°):** 160°/140°
- **Backlight Life:** 50,000 hrs
- **Contrast Ratio:** 800:1

1.2.5 Touchscreen

- **Light Transmission:** 90% ± 3%
- **Type:** Projected capacitive (P-CAP) multi-touch

1.2.6 Environment

- **Operating Temperature:** -20 ~ 60 °C (-4 ~ 140 °F)
The Temperature of Safety Certification is from -20 ~ 50 °C (-4 ~ 140 °F)
- **Storage Temperature:** -30 ~ 70 °C (-22 ~ 158 °F)
- **Humidity:** 10 ~ 95% RH @ 40 °C, non-condensing
- **Ingress Protection:** Compliant with IP66 on front panel
- **Vibration Protection:** 1 Grms random vibration (5 ~ 500 Hz) during operation (with M.2 2242)

1.2.7 EMC and Safety

- **EMC:** CE, FCC Class A, BSMI
- **Safety:** UL, CCC

1.2.8 Power

- **Input Voltage:** 24VDC ± 20%
- **Power Consumption:** 19.2 W (typical)

1.2.9 External I/O

The arrangement of I/O ports is shown below.

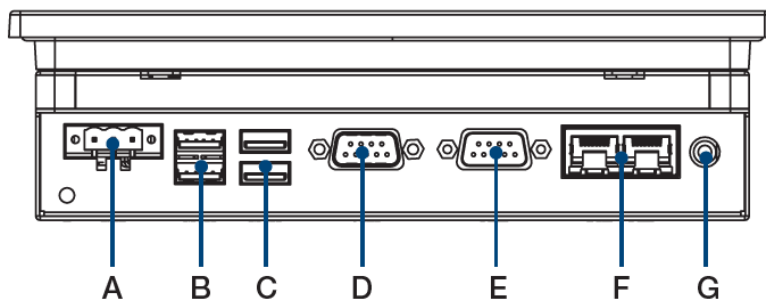

- | | |
|-------------------|---------------------------|
| A. Power receptor | E. RS-232/422/485 (COM 2) |
| B. USB 3.0 | F. LAN (10/100/1000) |
| C. USB 2.0 | G. Line Out |
| D. RS-232 (COM 1) | |

1.3 Dimensions and Cutout

- **Dimensions (W x H x D):** 205 x 146.92 x 55.7mm (8.07 x 5.78 x 2.20 inch)

Unit: mm

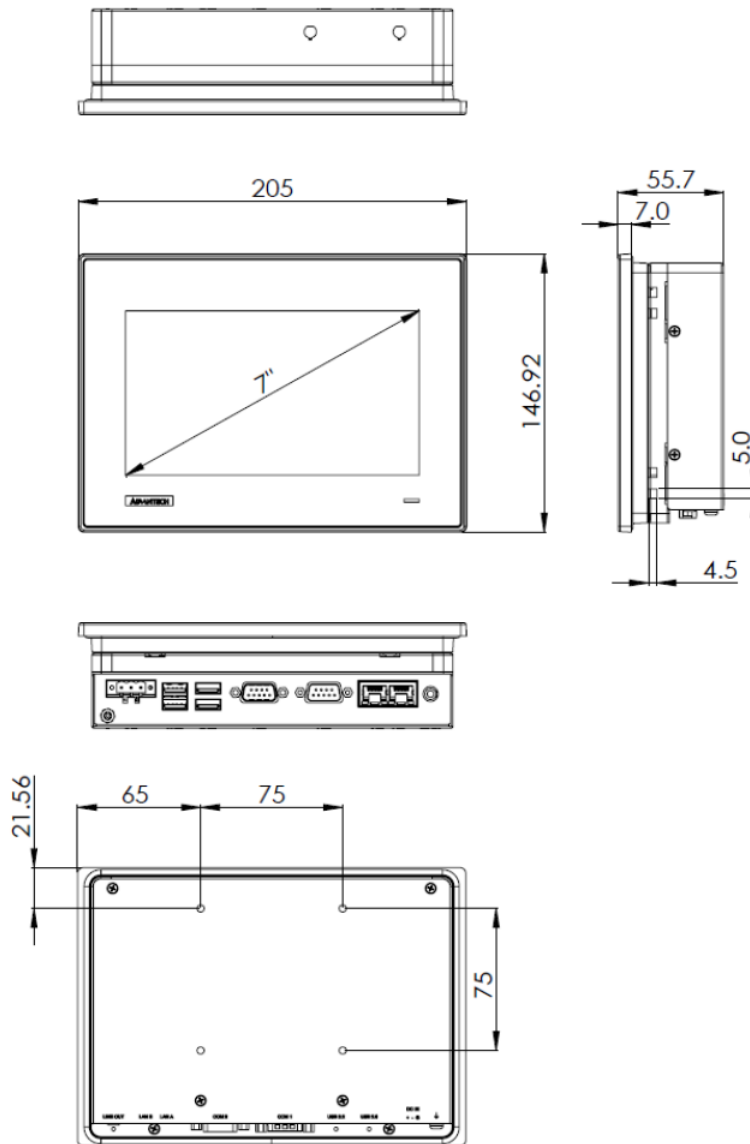

- **Cutout Dimensions:** 192 x 138.5 mm (7.56 x 5.45 inch)

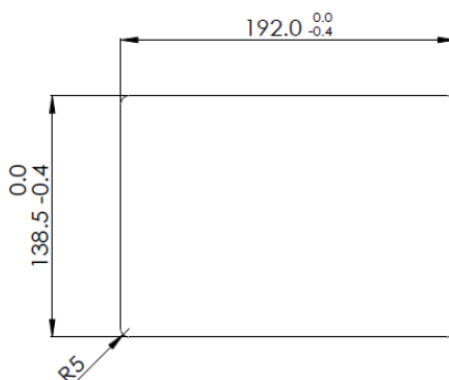

Chapter 2

Installation

2.1 Transport and Unpacking

2.1.1 Transport

When accepting a delivery, please check the packaging for visible transportation damage and check the delivery for completeness by comparing it with your order form. If you notice any shipping damage or inconsistencies between the contents and your order, please inform the responsible delivery service immediately. During transportation, the TPC system should be protected from excessive mechanical stress. If the TPC system is transported or stored without packaging, shocks, vibrations, pressure, and moisture may impact the unprotected unit. Additionally, damaged packaging indicates that ambient conditions have already had a massive impact on the device. Therefore, please use the original packaging during transportation and storage. If the TPC system is transported in cold weather or is exposed to extreme variations in temperature, ensure that moisture (condensation) does not build up on or inside the HMI device. Moisture can result in short circuits and damage to the device. To avoid this, store the TPC system in a dry environment and bring the system to room temperature before powering it up. If condensation occurs, a delay time of approximately 12 hours must be allowed to ensure that the system is completely dry before being switched on.

2.1.2 Unpacking

1. Unpack the TPC-307W device.
2. Configure the power mode if necessary (default: AT mode). See Section 2.5.
3. Connect the power connector to the 24 VDC power lines of a power adapter or in-house power source. DC power source shall be complied with ES1 and PS2 requirements, output rating is 24 Vdc, minimum 2.5A, with minimum operating temperature 60°C, and has to be evaluated according to IEC/UL 60950-1 and/or IEC/UL 62368-1.

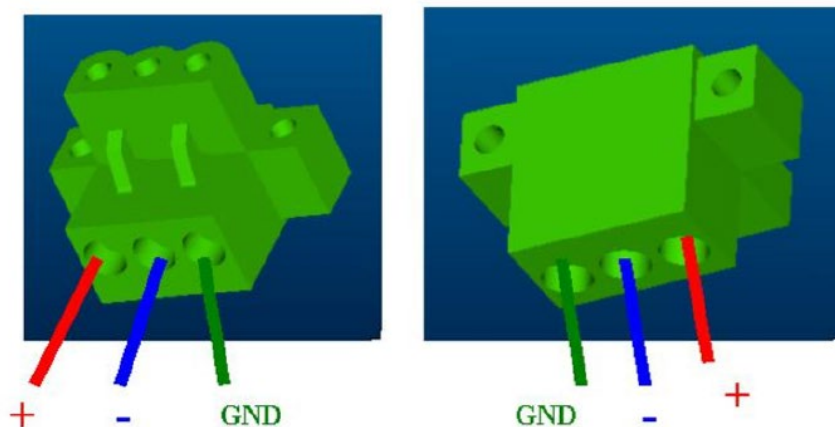



Figure 2.1 Power Connector and Power Lines

Warning! *The system may get damaged when the power is turned on and the power source is not connected to the correct pins.*
 *Le système peut être endommagé lorsque l'alimentation est allumée et que la source d'alimentation n'est pas connectée aux broches appropriées.*

4. Plug the power lines into the system power receptor.

The terminal block is suitable for 12-24 AWG. Torque value 3 lb-in. Use copper conductors only. Must be installed by skilled person.

At. No.	Wire Range	Wire Type	FW	TQ Lb In.	V	A	UG	CA
MC420, MC421 (1C)	16-26	Cu	2	3	300	10	B, C	2(105), 4*

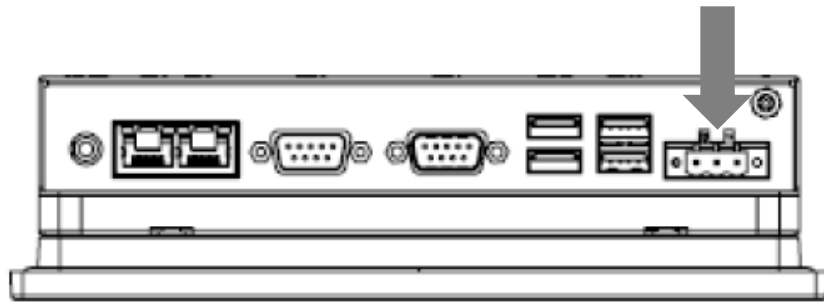
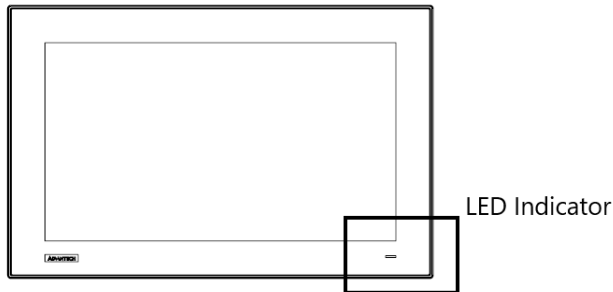

Figure 2.2 Power Connector

5. Power on the system. The power LED turns to blue.



LED Indicator:
 Off - "dark"
 ON - "blue"
 Standby - "orange"

Figure 2.3 Power LED

6. Calibrate the touchscreen.

2.2 Panel Mount

There is an adhesive waterproof gasket on the front bezel. Make sure the waterproof gasket is in position before installing the TPC-307W panel computer into the panel opening.

1. Install the TPC into the panel opening. For adequate air circulation, the TPC requires a certain clearance on all sides. The following diagram illustrates the minimum clearance (100mm) and the air inlet and outlet directions (blue arrows). The suggested mounting panel thickness is less than 6mm (0.236").

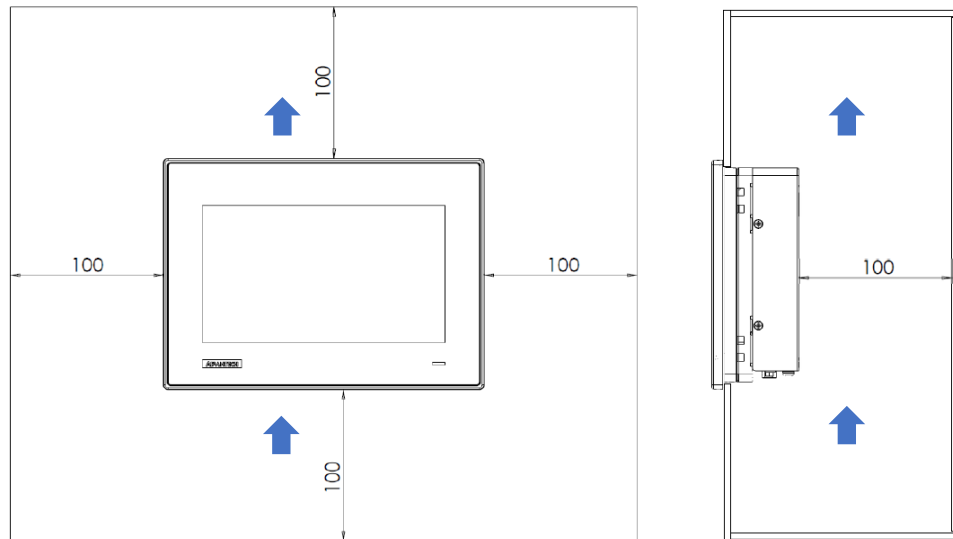

Unit: mm

Figure 2.4 Panel Mounting – Positioning

2. Find the four clamps and four long screws in the accessory pack. Insert the screws (M4 x 25mm) into each clamp and tighten them to fasten the clamp in place.

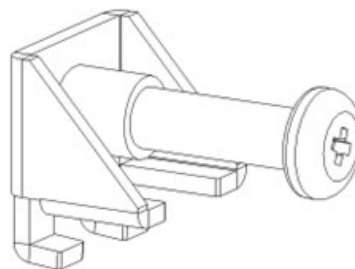

Figure 2.5 Panel Mounting – Clamp with Screw

- Hook the clamp into the holes around the four sides of the bezel and fasten the screws (torque: 2 kgf-cm). These screws will push the mounting panel and secure the unit.

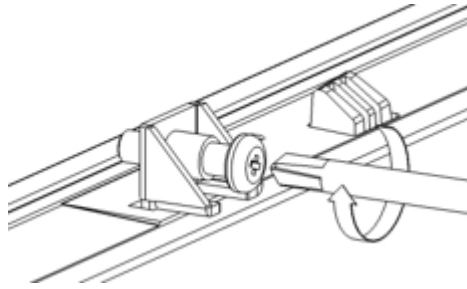

Figure 2.6 Panel Mounting – Clamp Fixing

2.3 VESA Mount

The TPC-307W's rear cover features four VESA mounting (75 x 75 mm) holes. The VESA mounting kit needs to be installed by 4pcs M4x10L screws. Please use suitable mounting apparatus to avoid risk of injury.

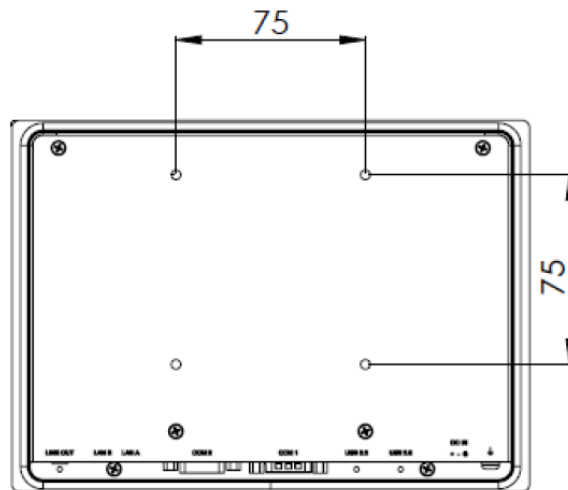

Figure 2.7 VESA Mounting

2.4 Cabinet Installation and Earth Grounding Setup

Follow the following steps to setup TPC-307W system, and please pay attention that Ground pin of TPC-307W system should be connected to earth ground. Under this circumstance, TPC-307W system could have the best performance such as EMI immunity, ESD immunity, surge immunity and also system isolation. If the TPC-307W system is embedded in the cabinet, the TPC-307W system's ground, cabinet's ground and earth ground should be connected together.

2.4.1 Installing TPC into Cabinet

1. Connect the cabinet to earth ground.
2. Embed null TPC-307W system into the cabinet without any I/O cable and power.

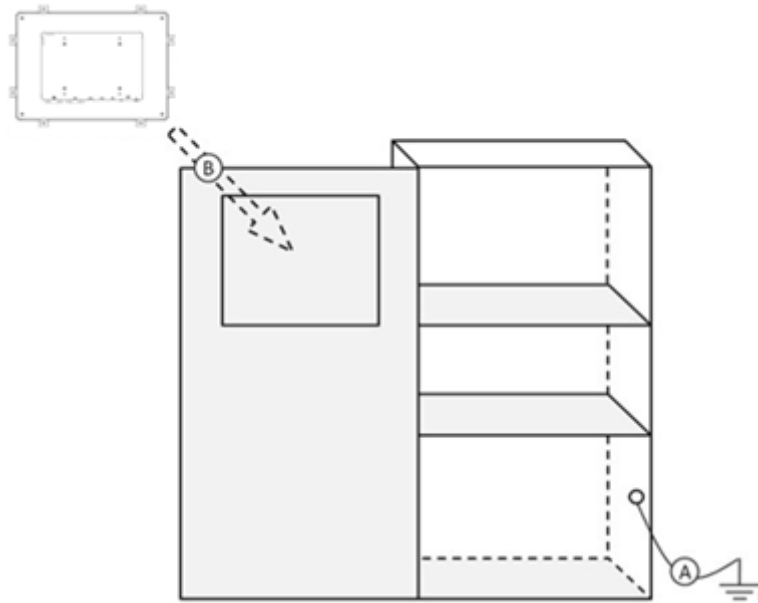

Figure 2.8 Cabinet Installation

2.4.2 System Wiring

1. Connect the cabinet to earth ground.
2. Ensure that all cabinet has been grounded together.
3. Connect the ground of the power supply to the cabinet.
4. Connect the ground pin of the TPC-307W system to the cabinet.
5. Connect the I/O to the controller if needed.
6. Connect the V+ and V- of power supply to the TPC-307W system.
7. While completing step 1 to 6 step by step, you can supply power to the TPC-307W system now.

NOTE! Make sure all wires follow the installation guidelines to avoid performance issues.



2.5 System Configuration

TPC-307W is a compact touch panel with IIoT functions for industrial applications. The system setup will be completed by the dealer or system integrator prior to delivery. However, users may still need to access the system to adjust configuration, such as the interfaces or boot modes. Before powering on, please open the rear bracket and select the correct power mode.

2.5.1 Rear Bracket Removal

The rear bracket is a part of the system that requires removal before changing the settings or installing new modules. It is secured to the system by 8 screws as shown below. After taking out all the screws, gently lift the rear bracket and place it aside. Care should be taken not to damage the system or the bracket during this process.

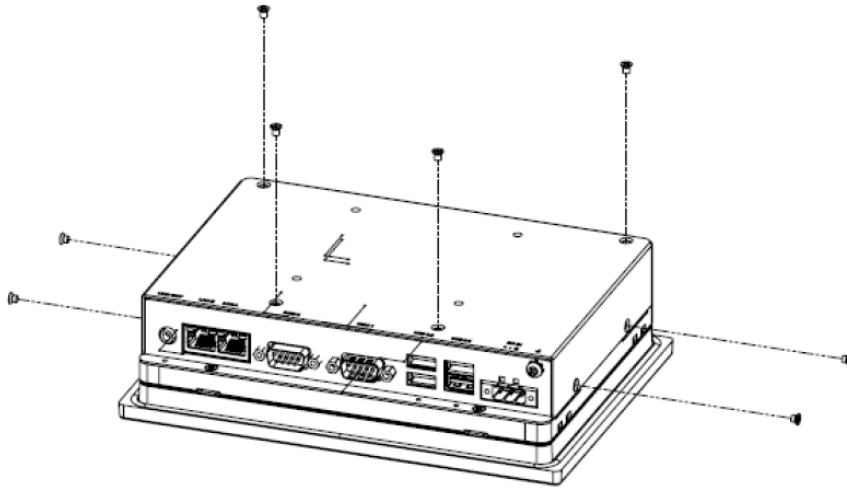

2.5.2 AT/ATX Jumper Setting (PSON1)

Power mode can be set via this jumper on the TPC-307W motherboard as shown below.

Table 2.1: AT/ATX Function

Description	This jumper is used to select Power ON mode
Default	(1-2)
(2-3)	ATX
(1-2)	AT

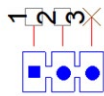

(1-2) AT power

PSON1
PH_3x1V_2.00mm



(2-3) ATX power

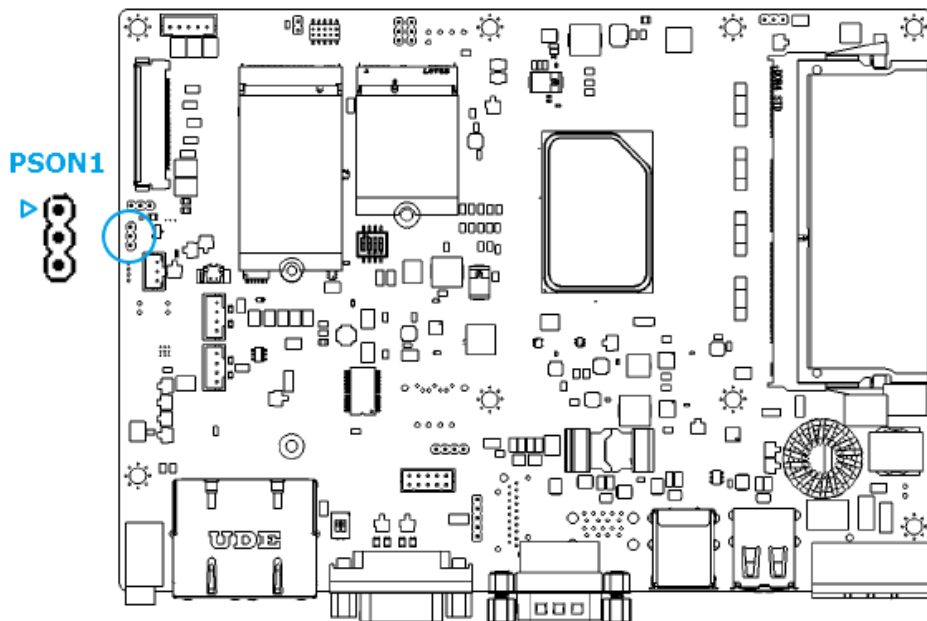

Warning! *Incorrect or undefined switches can cause damage to the system when powered on.*



Des commutateurs incorrects ou non définis peuvent endommager le système lors de la mise sous tension.

2.5.3 Enabling Wake On Touch

To use the Wake On Touch feature, you must disable the **ErP Function** in the BIOS. Follow the steps below:

1. Restart your system and enter the BIOS setup (usually by pressing **Del** during startup).
2. Navigate to:
Chipset > PCH-IO Configuration
3. Locate the **ErP Function** setting and set it to **Disabled**.

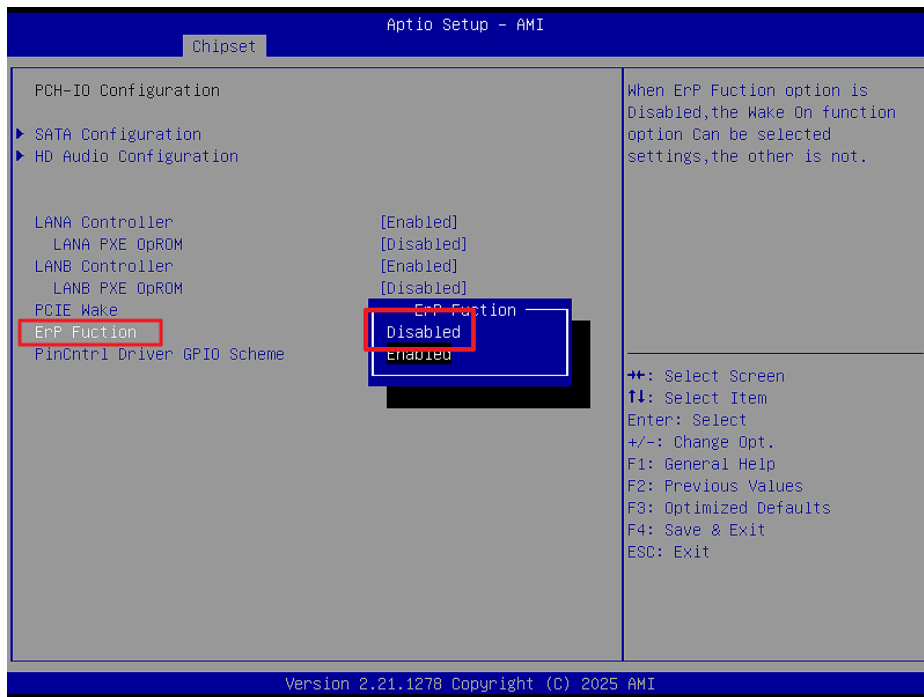

4. Save and exit the BIOS.

Once ErP is disabled, the Wake On Touch feature will be enabled.

Appendix **A**

Connectors

A.1 Jumper and Connector Location

A.1.1 Board Layout

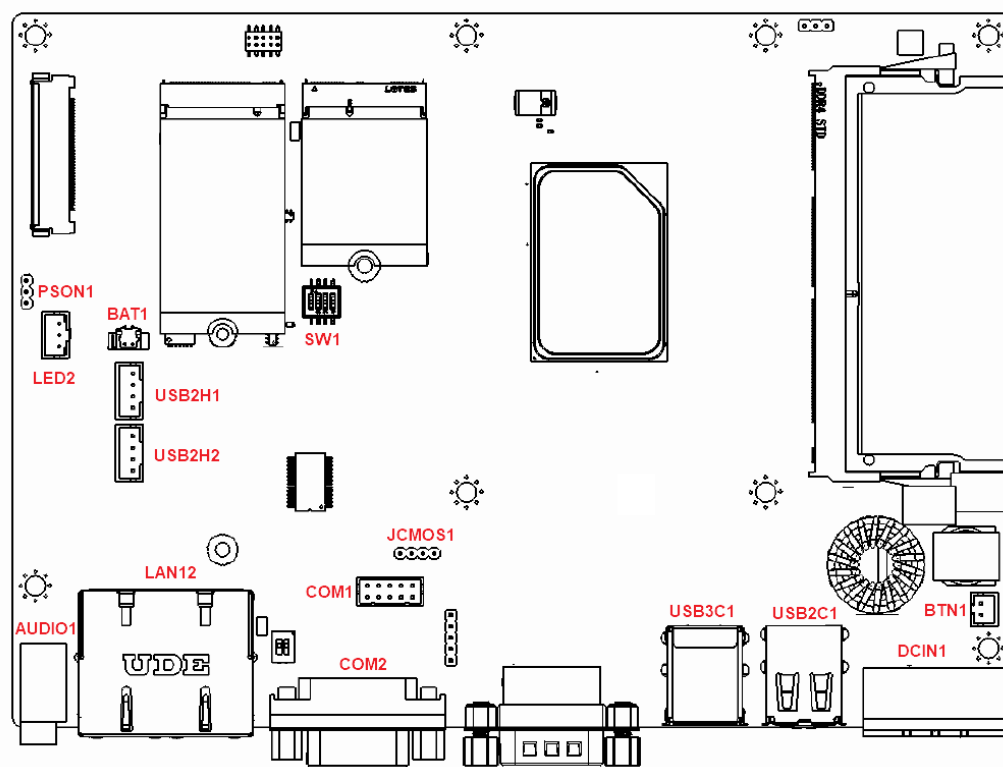

Figure A.1 Board Layout - Top View

Table A.1: Connector and Jumpers

Label	Function
JCMOS1	Clear CMOS jumper
SW1	LCD resolution select jumper
BTN1	Power button connector
USB2H1	Internal USB connector 1
USB2H2	Internal USB connector 2
LED2	LED indicator connector
BAT1	RTC battery connector
COM1	COM1 RS-232 connector
COM2	COM2 RS-232/422/485 connector
USB3C1	USB 3.0 connector
USB2C1	USB 2.0 connector
DCIN1	Power input connector
LAN12	LAN RJ45 connectors
AUDIO1	Audio connector

A.2 Jumper Settings and Descriptions

A.2.1 CMOS Clear Function (JCMOS1)

Table A.2: CMOS Clear Function

Description	This jumper is used to select CMOS clear
Default	(2-3)
(1-2)	CLR RTC Register
(2-3)	Normal (Default)
(3-4)	Clear CMOS

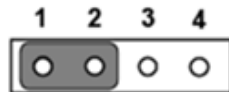

(1-2) CLR RTC Register

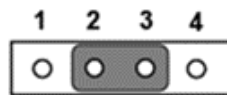
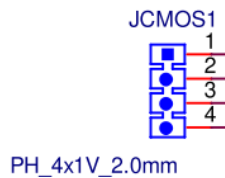

(2-3) Normal, default

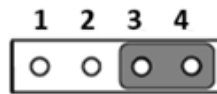

(3-4) Clear CMOS

A.2.2 LCD Resolution Select (SW1)

Table A.3: LCD Resolution Select

Description	This switch is used to select LCD resolution
Default	1024*600 (24-bit) PWM 1KHz
(1-2-3-4)	OFF-ON-ON-ON

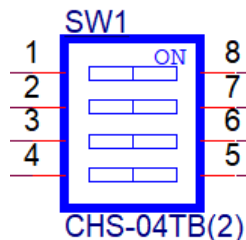

A.3 Connector Pin Definition

A.3.1 Power Button Connector (BTN1)

Table A.4: Power Button Connector (BTN1)

Pin	Signal
1	ATX_PWRBTN#
2	GND



A.3.2 Internal USB Connector (USB2H1 & USB2H2)

Table A.5: Internal USB Connector (USB2H1 & USB2H2)

Pin	Signal
1	+V5
2	D-
3	D+
4	GND



A.3.3 LED Indicator Connector (LED2)

Table A.6: LED Indicator Connector (LED2)

Pin	Signal
1	Orange light
2	GND
3	Blue light

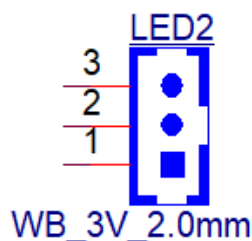

A.3.4 RTC Battery Connector (BAT1)

Table A.7: RTC Battery Connector (BAT1)

Pin	Signal
1	+VBAT
2	GND

BAT1

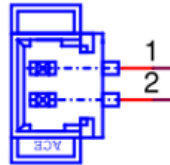

WB_2V_S1.25mm

A.3.5 COM1 RS-232 Connector (COM1)

Table A.8: Internal COM Port Connector (COM1)

Pin	Signal
1	DCD#
2	RX
3	TX
4	DTR#
5	GND
6	DSR
7	RTS#
8	CTS#
9	RI#
10	NA

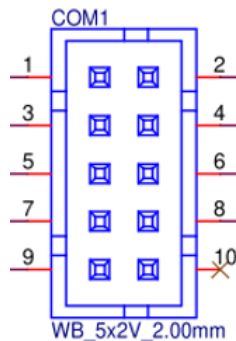

A.3.6 COM2 RS-232/422/485 Connector (COM2)

Table A.9: COM2 RS-232/422/485 Connector (COM2)

Pin	RS232	RS422	RS485
1	DCD	TX-	Data-
2	RX	TX+	Data+
3	TX	RX+	
4	DTR	RX-	
5	GND	GND	GND
6	DSR		
7	RTS		
8	CTS		
9	RI		

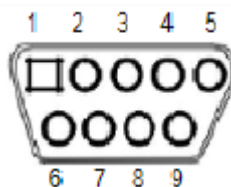

A.3.7 Power Input Connector (DCIN1)

Table A.10: Power Input Connector (DCIN1)

Pin	Signal
1	Power In V+
2	Power In V- (GND)
3	GND_EARTH

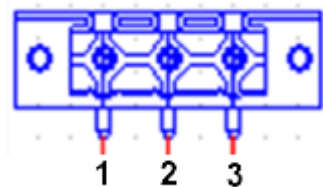

Appendix **B**

BIOS Setup

With the AMI BIOS Setup program, users can modify the BIOS settings and control various system features. This chapter describes the basic navigation of the BIOS Setup Utility.



AMI's BIOS ROM has a built-in setup program that allows users to modify the basic system configuration. The setup information is stored in flash ROM to ensure it is retained when the system is powered off.

B.1 Entering Setup

Turn on the computer and check for the patch code. If there is a number assigned to the patch code, it means that the BIOS supports your CPU. If there is no number assigned to the patch code, contact an Advantech application engineer to obtain an up-to-date patch code file. This will ensure that the CPU status is valid. After ensuring that you have a number assigned to the patch code, press to access the BIOS Setup Utility.

B.2 Main Setup

Upon entering the BIOS Setup Utility, users will be on the Main setup screen. At any point during the configuration, users can return to the Main setup screen by selecting the Main tab. There are two Main setup options, which are described in this section. The Main setup screen is shown below.

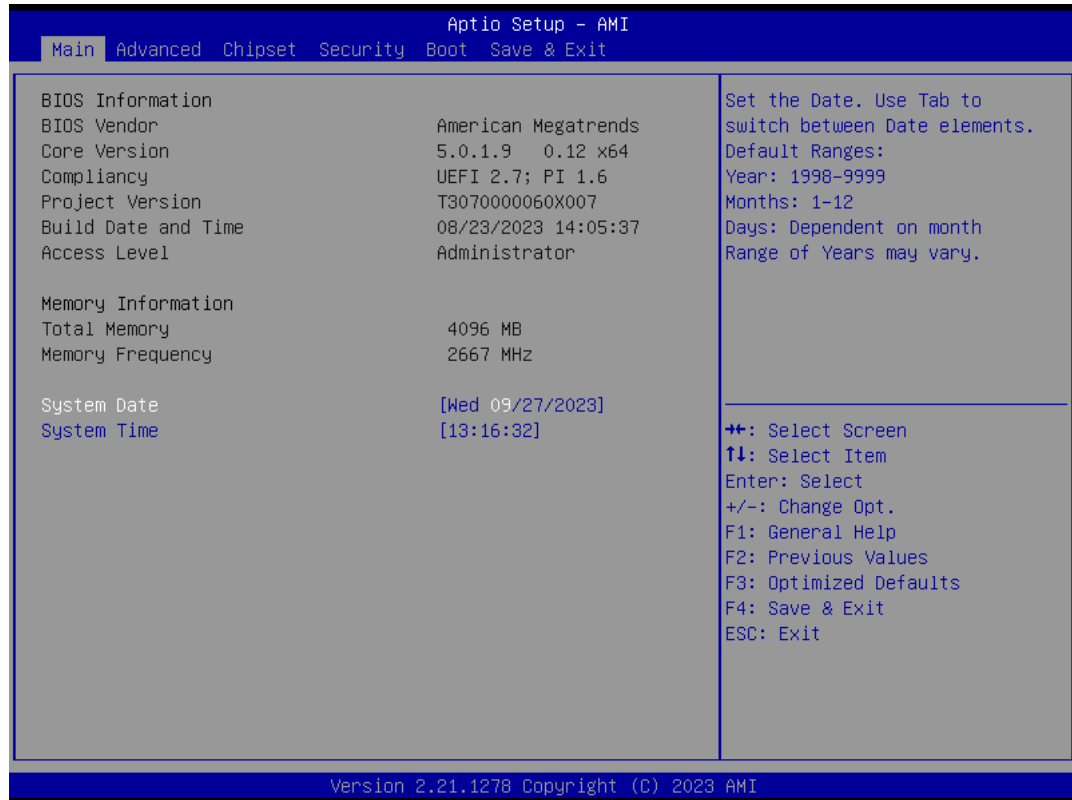

The Main setup screen has two main frames. The left frame displays all the options that can be configured. Grayed-out options cannot be configured, whereas options presented in blue can be configured. The right frame displays the key legend.

Above the key legend is an area reserved for a text message. When an option is selected in the left frame, it is highlighted in white. Often a text message will accompany an option.

■ System Time/System Date

Use this option to change the system time and date. Highlight System Time or System Date using the <Arrow> keys. Enter new values via the keyboard. Press the <Enter> key to move between fields. The date must be entered in MM/DD/YY format. The time must be entered in HH:MM:SS format.

B.3 Advanced BIOS Features Setup

Select the Advanced tab from the TPC-307W setup screen to enter the Advanced BIOS Setup screen. Users can select any of the items in the left frame of the screen, such as ACPI Settings and hit <enter> to access the submenu for that item. Users can display an Advanced BIOS Setup option by highlighting it using the <Arrow> keys. All Advanced BIOS Setup options are described in this section. The Advanced BIOS setup screen is shown below. The submenus are described on the following pages.



B.3.1 CPU Configuration

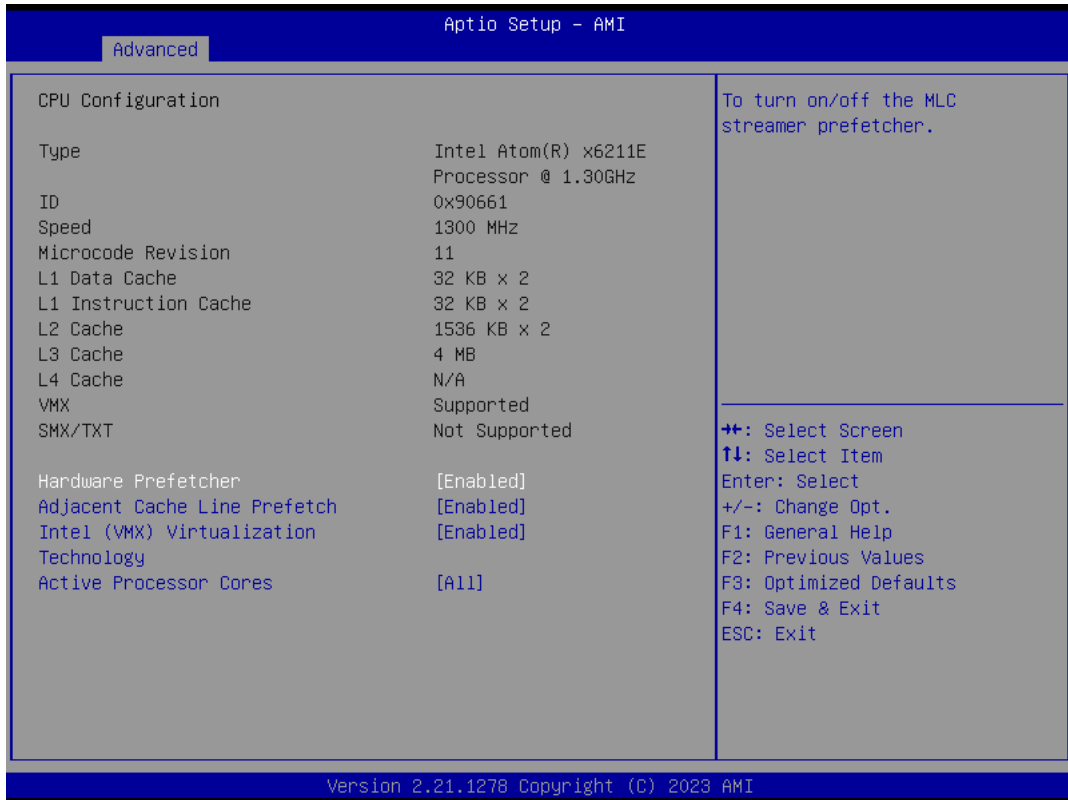

- **Hardware Prefetcher**
To turn on/off the MLC streamer prefetcher
- **Adjacent Cache Line Prefetch**
To turn on/off prefetching of adjacent cache lines
- **Intel (VMX) Virtualization Technology**
When enabled, a VMX can utilize the additional hardware capabilities provided by Vanderpool Technology
- **Active Processor Cores**
Number of cores to enable in each processor package

B.3.2 Power & Performance

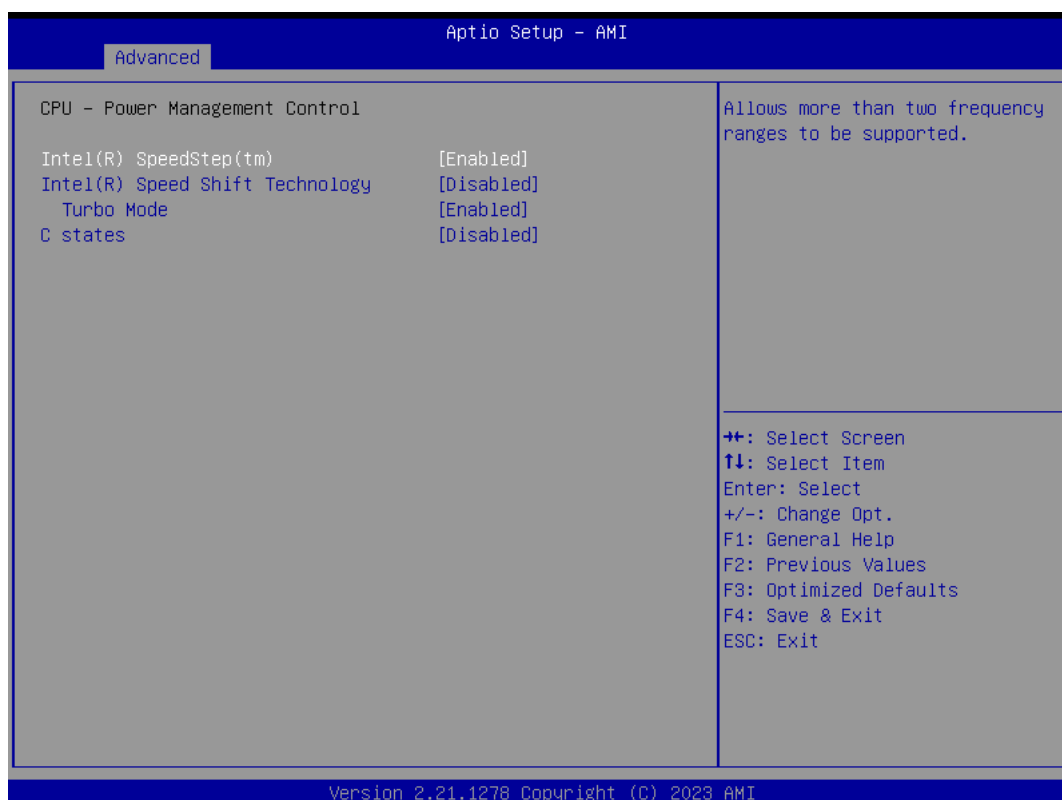

- **Intel(R) SpeedStep(tm)**
This item allows more than two frequency ranges to be supported.
- **Intel(R) Speed Shift Technology**
This item allows users to enable/disable Intel® Speed Shift Technology support. Enable it will expose the CPPC v2 interface to allow for hardware controlled P-states.

- **Turbo Mode**

This item allows users to enable/disable processor turbo mode (Intel Speed Step or Intel Speed Shift should be enabled).

- **C States**

This item allows users to enable/disable CPU power management. This will enable the CPU to go to C states when not 100% utilized.

B.3.3 PCH-FW Configuration

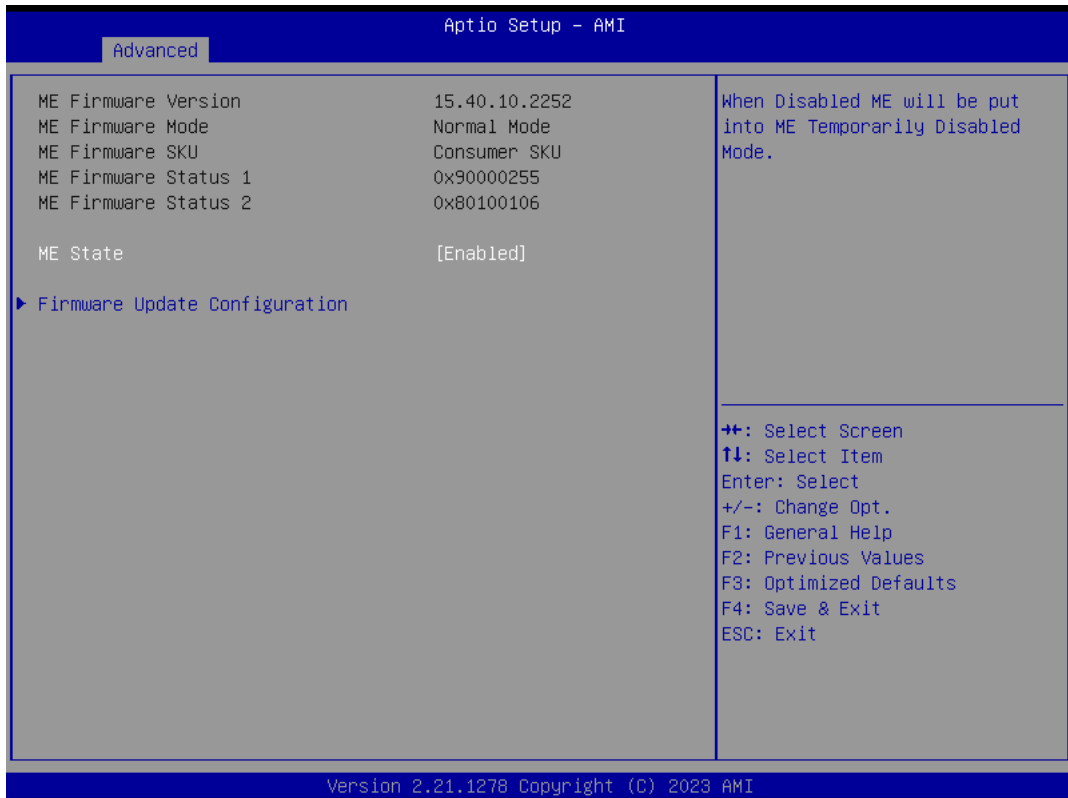

- **ME State**

When this item is disabled, ME will be put into ME Temporarily Disabled Mode.

- **Firmware Update Configuration**

This item allows users to configure the management engine technology parameters.

B.3.4 Trusted Computing



- **Security Device Support**

This item allows users to enable/disable BIOS support for security devices. The OS will not show the security devices. The TCG EFI protocol and INT1A interface will not be available.
- **SHA-1 PCR Bank**

This item allows users to enable/disable SHA-1 PCR bank.
- **SHA256 PCR Bank**

This item allows users to enable/disable SHA256 PCR bank.
- **SHA384 PCR Bank**

This item allows users to enable/disable SHA384 PCR bank.
- **Pending Operation**

This item allows users to schedule an operation for the security device. Note: The computer must be restarted to change the security device state.
- **Platform Hierarchy**

This item allows users to enable/disable platform hierarchy.
- **Storage Hierarchy**

This item allows users to enable/disable storage hierarchy.
- **Endorsement Hierarchy**

This item allows users to enable/disable endorsement hierarchy.
- **TPM2.0 UEFI Spec Version**

This item allows users to select the TCG2 spec version supported.

TCG_1_2: The compatible mode for Win8/10.

TCG_2: Supports new TCG2 protocol and event formats for Win10 or later.

- **Physical Presence Spec Version**

This item allows users to enable support for PPI spec version 1.2 or 1.3.
Note: Some HCK tests may not support version 1.3.

- **Device Select**

TPM 1.2: select this to restrict support to TPM 1.2 devices.

TPM 2.0: select this to restrict support to TPM 2.0 devices

Auto: select this to support both; TPM 2.0 devices by default; if not found, TPM 1.2 devices will be enumerated

B.3.5 ACPI Settings



- **Enable ACPI Auto Configuration**

This item allows users to enable/disable BIOS ACPI auto configuration.

- **Enable Hibernation**

This item allows users to enable/disable the system hibernation function (OS/S4 Sleep State). This option may not be available with some operating systems.

- **ACPI Sleep State**

This item allows users to select the highest ACPI sleep state when the Suspend button is pressed.

B.3.6 NCT61260 Super IO Configuration

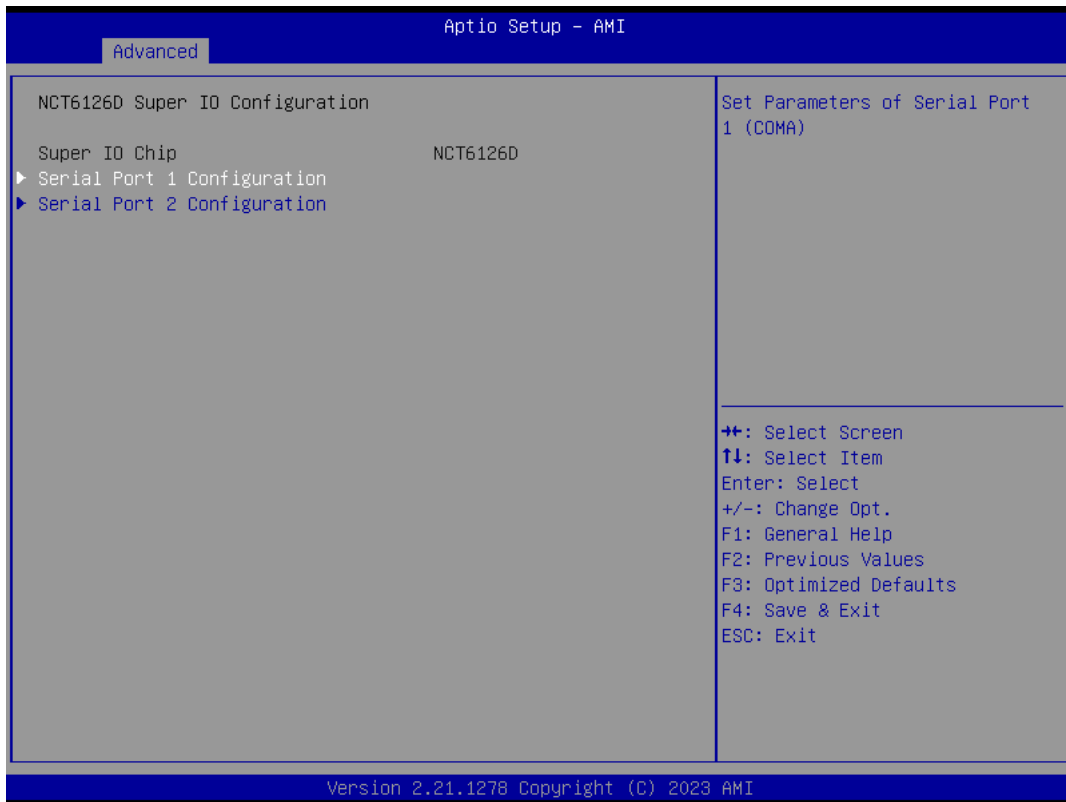

- **Serial Port 1 Configuration**
Set Parameters of Serial Port 1 (COMA).
- **Serial Port 2 Configuration**
Set Parameters of Serial Port 2 (COMB).

B.3.7 NCT61260 HW Monitor

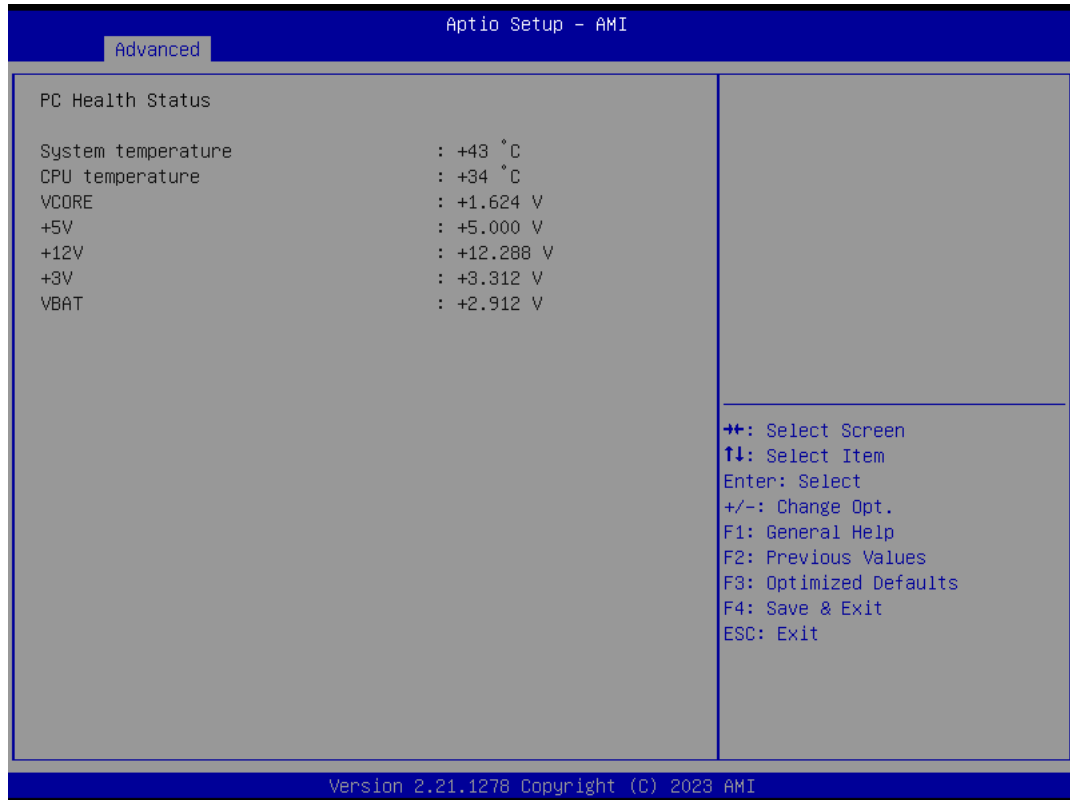

B.3.8 USB Configuration

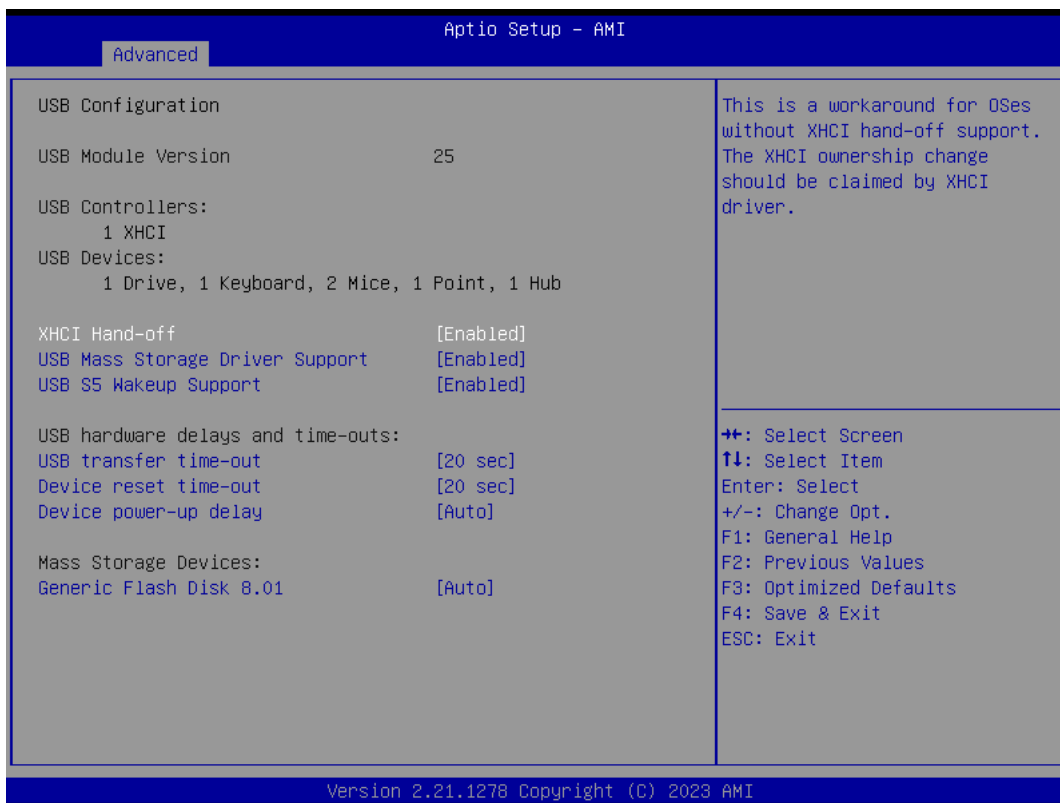

- **XHCI Hand-Off**

This is a workaround for operating systems without XHCI hand-off support. The XHCI ownership change should be conducted by the XHCI driver.
- **USB Mass Storage Driver Support**

This item allows users to enable/disable USB mass storage driver support.
- **USB S5 Wakeup Support**

This item allows users to enable/disable USB S5 wakeup support.
- **USB Transfer Time-Out**

This item allows users to set the time-out value for control, bulk, and Interrupt USB mass storage device transfers.
- **Device Reset Time-Out**

This item allows users to set the device reset command time-out.
- **Device Power-Up Delay**

This item allows users to Set the maximum time the device will take before reporting itself to the Host Controller. The Auto option uses the default value, which is 100 ms for a Root port. For a Hub port, the delay time is obtained from the Hub descriptor.

B.3.9 Network Stack Configuration

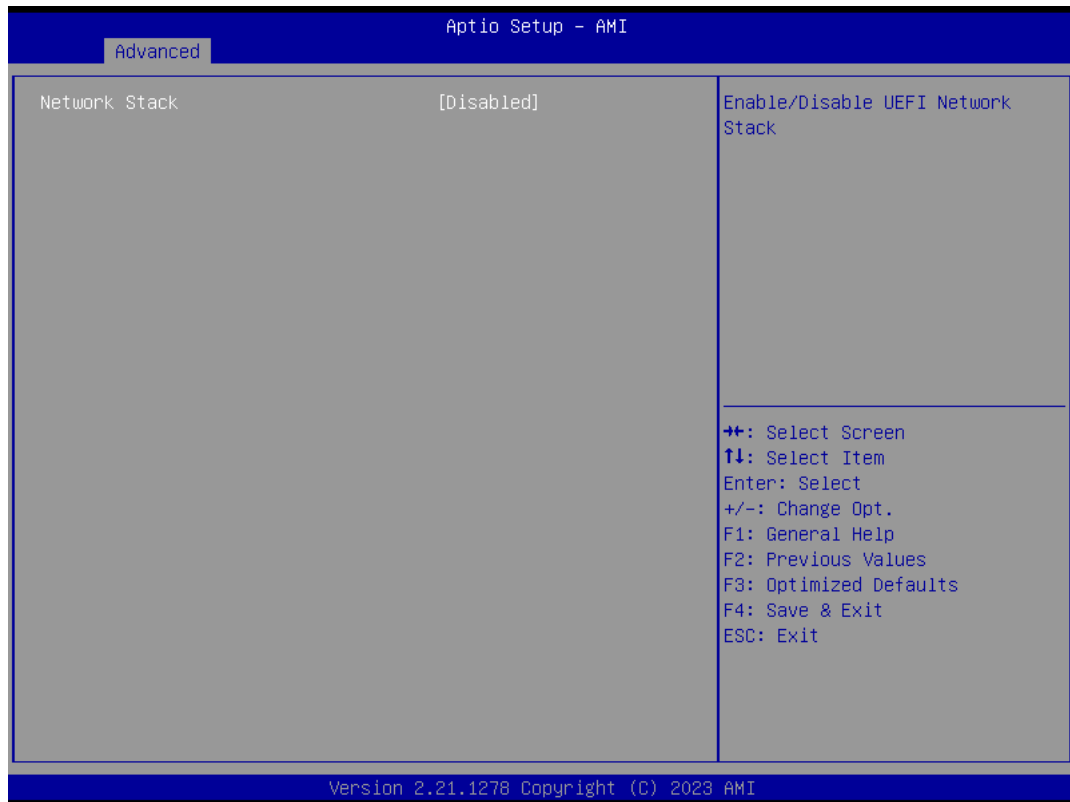

- **Network Stack**

This item allows users to enable or disable UEFI network stack.

B.3.10 NVMe Configuration

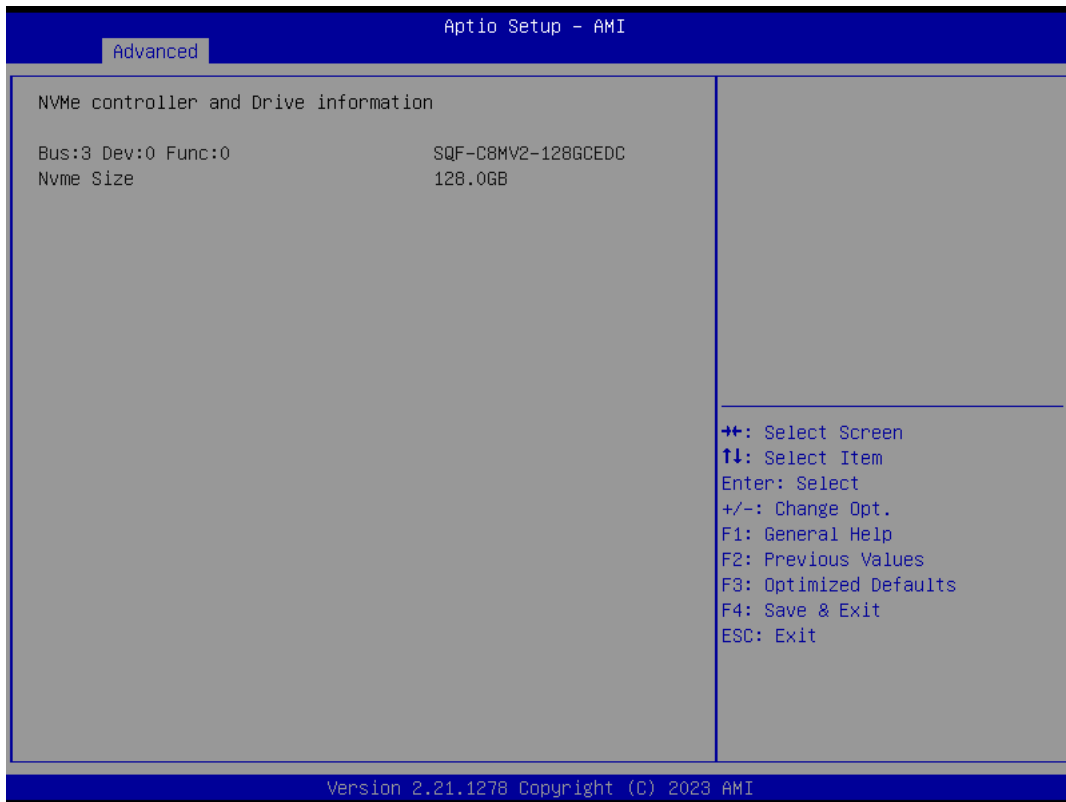

B.4 Chipset Configuration

B.4.1 System Agent (SA) Configuration

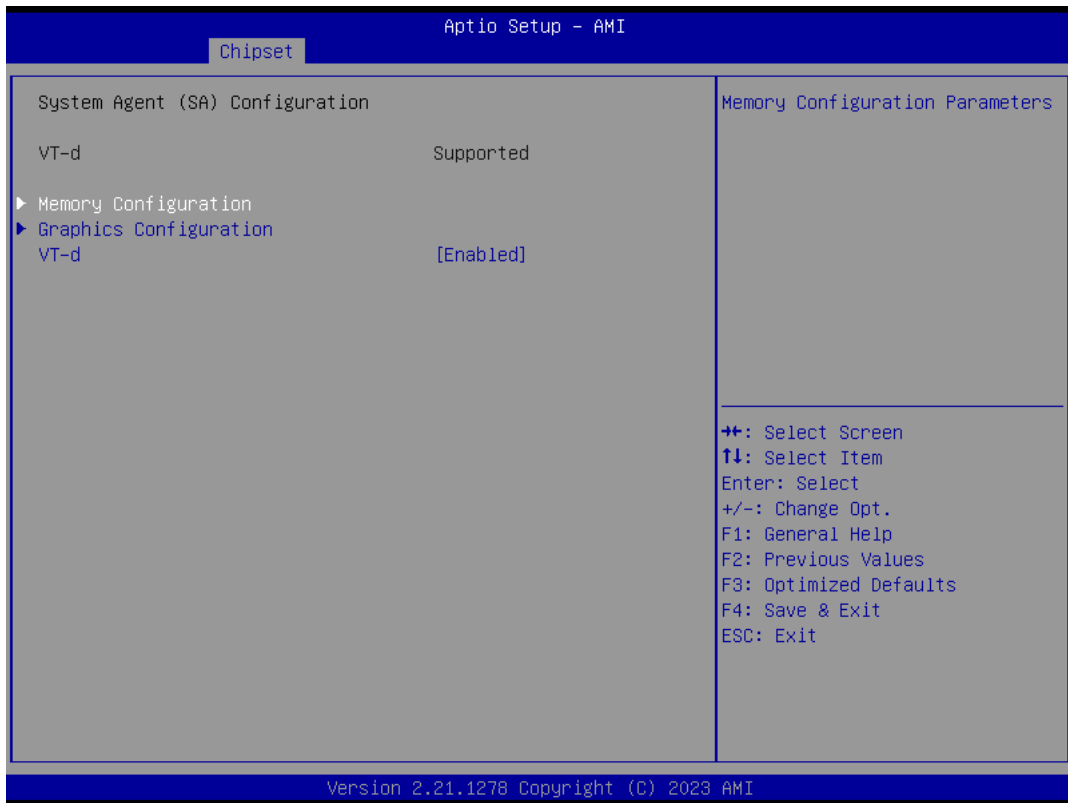

- **Memory Configuration**
This item allows users to view the memory parameters.
- **Graphics Configuration**
This item allows users to set graphics configuration parameters
- **VT-d**
This item allows users to enable or disable VT-d capability

B.4.2 PCH-IO Configuration



- **SATA Configuration**
This submenu allows users to set the SATA device settings.
- **HD Audio Configuration**
This submenu allows users to set the HD Audio subsystem configuration settings.
- **PCIE Wake**
This item allows users to enable or disable the PCIe device to wake up the system from S3/S4/S5 state.
- **ErP Function**
When this option is disabled, the wake on function can be selected.
Note: To enable the Wake On Touch function, please ensure that the ErP function is set to "Disabled".
- **PinCntrl Driver GPIO Scheme**
This item allows users to enable or disable PinCntrl Driver GPIO Scheme.

B.5 Security



- **Administrator Password**
Set administrator password
- **Secure Boot**
This item allows users to access a submenu to configure secure boot settings.

B.6 Boot



- **Setup Prompt Timeout**
This item allows users to set the number of seconds to wait for setup activation key. 65535 (0xFFFF) means indefinite waiting.
- **Bootup NumLock State**
This item allows users to select the keyboard NumLock state.
- **Quiet Boot**
This item allows users to enable/disable quiet boot option.

B.7 Save & Exit



- **Save Charges and Exit**
This item allows users to exit the system setup after saving changes.
- **Discard Changes and Exit**
This item allows users to exit the system setup without saving changes.
- **Save Changes and Reset**
This item allows users to reset the system after saving changes.
- **Discard Changes and Reset**
This item allows users to reset the system without saving changes.
- **Save Changes**
This item allows users to save any changes to the setup options.
- **Discard Changes**
This item allows users to discard any changes to the setup options.
- **Restore Defaults**
This item allows users to restore/load default values for all setup options.
- **Save as User Defaults**
This item allows users to save all current settings as user defaults.
- **Restore User Defaults**
This item allows users to restore all setup options to the user default values.

www.advantech.com

Please verify specifications before quoting. This guide is intended for reference purposes only.

All product specifications are subject to change without notice.

No part of this publication may be reproduced in any form or by any means, such as electronically, by photocopying, recording, or otherwise, without prior written permission from the publisher.

All brand and product names are trademarks or registered trademarks of their respective companies.

© Advantech Co., Ltd. 2025