

User Manual

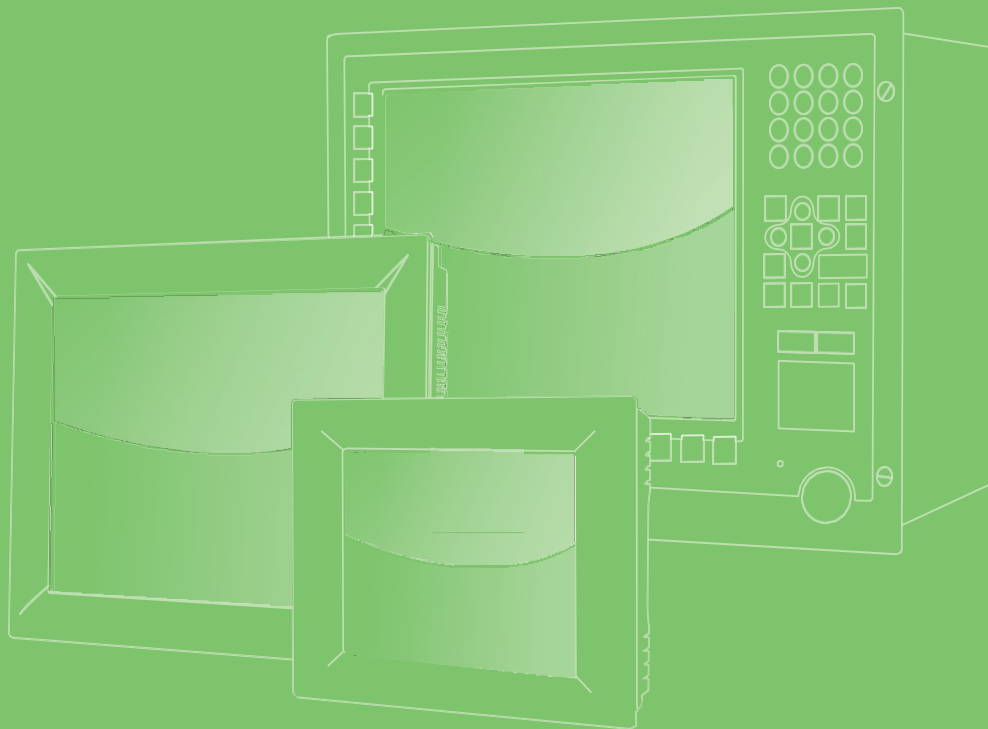

# TPC-B620

## Computing Box Module with Intel® R680E and H610E Chipset

製造商: 研華股份有限公司

地址: 台北市內湖區瑞光路26巷20弄1 F

電話: 02-27927818

**ADVANTECH**

*Enabling an Intelligent Planet*

---

## Copyright

The documentation and the software included with this product are copyrighted 2026 by Advantech Co., Ltd. All rights are reserved. Advantech Co., Ltd. reserves the right to make improvements in the products described in this manual at any time without notice. No part of this manual may be reproduced, copied, translated or transmitted in any form or by any means without the prior written permission of Advantech Co., Ltd. Information provided in this manual is intended to be accurate and reliable. However, Advantech Co., Ltd. assumes no responsibility for its use, nor for any infringements of the rights of third parties, which may result from its use.

## Acknowledgements

Intel and Pentium are trademarks of Intel Corporation.  
Microsoft Windows and MS-DOS are registered trademarks of Microsoft Corp.  
All other product names or trademarks are properties of their respective owners.

This Manual Covers the Following Models:

TPC-B620 series

- TPC-B620R-F00A, TPC-B610H-F00A
- TPCB620RF00A2601-T, TPCB620RF00A2602-T, TPCB620RF00A2603-T, TPCB620RF00A2604-T, TPCB620RF00A2605-T, TPCB620RF00A2606-T, TPCB620RF00A2701-T, TPCB620RF00A2702-T, TPCB620RF00A2703-T, TPCB620RF00A2704-T, TPCB620RF00A2705-T, TPCB620RF00A2706-T, TPCB620RF00A2801-T, TPCB620RF00A2802-T, TPCB620RF00A2803-T, TPCB620RF00A2804-T, TPCB620RF00A2805-T, TPCB620RF00A2806-T, TPCB620RF00A2901-T, TPCB620RF00A2902-T, TPCB620RF00A2903-T, TPCB620RF00A2904-T, TPCB620RF00A2905-T, TPCB620RF00A2906-T
- TPCB620HF00A2601-T, TPCB620HF00A2602-T, TPCB620HF00A2603-T, TPCB620HF00A2604-T, TPCB620HF00A2605-T, TPCB620HF00A2606-T, TPCB620HF00A2701-T, TPCB620HF00A2702-T, TPCB620HF00A2703-T, TPCB620HF00A2704-T, TPCB620HF00A2705-T, TPCB620HF00A2706-T, TPCB620HF00A2801-T, TPCB620HF00A2802-T, TPCB620HF00A2803-T, TPCB620HF00A2804-T, TPCB620HF00A2805-T, TPCB620HF00A2806-T, TPCB620HF00A2901-T, TPCB620HF00A2902-T, TPCB620HF00A2903-T, TPCB620HF00A2904-T, TPCB620HF00A2905-T, TPCB620HF00A2906-T

Part No.  
Printed in Taiwan

Edition 1  
March 2026

## Product Warranty (2 years)

Advantech warrants to you, the original purchaser, that each of its products will be free from defects in materials and workmanship for two years from the date of purchase.

This warranty does not apply to any products which have been repaired or altered by persons other than repair personnel authorized by Advantech, or which have been subject to misuse, abuse, accident or improper installation. Advantech assumes no liability under the terms of this warranty as a consequence of such events.

Because of Advantech's high quality-control standards and rigorous testing, most of our customers never need to use our repair service. If an Advantech product is defective, it will be repaired or replaced at no charge during the warranty period. For out-of-warranty repairs, you will be billed according to the cost of replacement materials, service time and freight. Please consult your dealer for more details.

If you think you have a defective product, follow these steps:

1. Collect all the information about the problem encountered. (For example, CPU speed, Advantech products used, other hardware and software used, etc.) Note anything abnormal and list any onscreen messages you get when the problem occurs.
2. Call your dealer and describe the problem. Please have your manual, product, and any helpful information readily available.
3. If your product is diagnosed as defective, obtain an RMA (return merchandise authorization) number from your dealer. This allows us to process your return more quickly.
4. Carefully pack the defective product, a fully-completed Repair and Replacement Order Card and a photocopy proof of purchase date (such as your sales receipt) in a shippable container. A product returned without proof of the purchase date is not eligible for warranty service.
5. Write the RMA number visibly on the outside of the package and ship it prepaid to your dealer.

## Declaration of Conformity

### CE

This product has passed the CE test for environmental specifications when shielded cables are used for external wiring. We recommend the use of shielded cables. This kind of cable is available from Advantech. Please contact your local supplier for ordering information.

### FCC Class A

Note: This equipment has been tested and found to comply with the limits for a Class A digital device, pursuant to part 15 of the FCC Rules. These limits are designed to provide reasonable protection against harmful interference when the equipment is operated in a commercial environment. This equipment generates, uses, and can radiate radio frequency energy and, if not installed and used in accordance with the instruction manual, may cause harmful interference to radio communications. Operation of this equipment in a residential area is likely to cause harmful interference in which case the user will be required to correct the interference at his own expense.

## A 级产品

警告：在居住环境中，运行此设备可能会造成无线电干扰。

## 甲類警語

甲類設備為其他符合甲類設備限制值之資訊技術設備，而非符合乙類資訊技術設備的限制值；雖然不可限制此類設備之行銷，但使用場所必須被限制，不得進行居住的環境中，且應於其機器本體及使用說明書中含有下列警語：

### 警告使用者

此為甲類資訊技術設備，於居住環境中使用時，可能會造成射頻干擾，在此種情況下，使用者會被要求採取某些適當的對策。

## Technical Support and Assistance

1. Visit the Advantech web site at [www.advantech.com/support](http://www.advantech.com/support) where you can find the latest information about the product.
2. Contact your distributor, sales representative, or Advantech's customer service center for technical support if you need additional assistance. Please have the following information ready before you call:
  - Product name and serial number
  - Description of your peripheral attachments
  - Description of your software (operating system, version, application software, etc.)
  - A complete description of the problem
  - The exact wording of any error messages

## Warnings, Cautions and Notes

**Warning!** *Warnings indicate conditions, which if not observed, can cause personal injury!*



*Les avertissements indiquent des conditions qui, si elles ne sont pas respectées, peuvent provoquer des blessures !*

**Caution!**



*Cautions are included to help you avoid damaging hardware or losing data. e.g. There is a danger of a new battery exploding if it is incorrectly installed. Do not attempt to recharge, force open, or heat the battery. Replace the battery only with the same or equivalent type recommended by the manufacturer. Discard used batteries according to the manufacturer's instructions.*

*Des précautions sont incluses pour vous aider à éviter d'endommager le matériel ou de perdre des données. par exemple. Il existe un risque d'explosion d'une nouvelle batterie si elle n'est pas correctement installée. N'essayez pas de recharger, d'ouvrir de force ou de chauffer la batterie. Remplacez la batterie uniquement par une pile identique ou équivalente recommandée par le fabricant. Jetez les piles usagées conformément aux instructions du fabricant.*



*Caution: Hot surface. Do not touch the Top Heatsink  
Attention: Surface chaude. Ne touchez pas au dissipateur thermique supérieur.*

**Note!** Notes provide optional additional information.



## Safety Instructions

1. Read these safety instructions carefully.  
Lisez attentivement ces consignes de sécurité.
2. Keep this User Manual for later reference.  
Conservez ce manuel d'utilisation pour référence ultérieure.
3. This product is not a personal computer.  
Ce produit n'est pas un ordinateur personnel.
4. Disconnect this equipment from any AC outlet before cleaning. Use a damp cloth. Do not use liquid or spray detergents for cleaning.  
Débranchez cet équipement de toute prise secteur avant de le nettoyer. Utilisez un chiffon humide. N'utilisez pas de détergents liquides ou en spray pour le nettoyage.
5. For plug-in equipment, the power outlet socket must be located near the equipment and must be easily accessible.  
Pour les équipements enfichables, la prise de courant doit être située à proximité de l'équipement et doit être facilement accessible.
6. Keep this equipment away from humidity.  
Gardez cet équipement à l'abri de l'humidité.
7. Put this equipment on a reliable surface during installation. Dropping it or letting it fall may cause damage.  
Placez cet équipement sur une surface fiable lors de l'installation. Le laisser tomber ou le laisser tomber peut causer des dommages.
8. The openings on the enclosure are for air convection. Protect the equipment from overheating. **DO NOT COVER THE OPENINGS.**  
Les ouvertures sur le boîtier sont destinées à la convection de l'air. Protégez l'équipement de la surchauffe. **NE COUVREZ PAS LES OUVERTURES.**
9. Make sure the voltage of the power source is correct before connecting the equipment to the power outlet.  
Assurez-vous que la tension de la source d'alimentation est correcte avant de connecter l'équipement à la prise de courant.
10. Position the power cord so that people cannot step on it. Do not place anything over the power cord.  
Placez le cordon d'alimentation de manière à ce que personne ne puisse marcher dessus. Ne placez rien sur le cordon d'alimentation.
11. All cautions and warnings on the equipment should be noted.  
Toutes les mises en garde et avertissements figurant sur l'équipement doivent être notés.
12. If the equipment is not used for a long time, disconnect it from the power source to avoid damage by transient overvoltage.  
Si l'équipement n'est pas utilisé pendant une longue période, débranchez-le de la source d'alimentation pour éviter tout dommage dû à une surtension transitoire.
13. Never pour any liquid into an opening. This may cause fire or electrical shock.  
Si l'équipement n'est pas utilisé pendant une longue période, débranchez-le de la source d'alimentation pour éviter tout dommage dû à une surtension transitoire.
14. Never open the equipment. For safety reasons, the equipment should be opened only by qualified service personnel.  
N'ouvrez jamais l'équipement. Pour des raisons de sécurité, l'équipement ne doit être ouvert que par un personnel de service qualifié.

15. If one of the following situations arises, get the equipment checked by service personnel:

Si l'une des situations suivantes se produit, faites vérifier l'équipement par le personnel de service :

- The power cord or plug is damaged.
- Liquid has penetrated into the equipment.
- The equipment has been exposed to moisture.
  
- The equipment does not work well, or you cannot get it to work according to the user's manual.
- The equipment has been dropped and damaged.
- The equipment has obvious signs of breakage.
- Le cordon d'alimentation ou la fiche est endommagé.
- Du liquide a pénétré dans l'équipement.
- L'équipement a été exposé à l'humidité.
- L'équipement ne fonctionne pas bien ou vous ne parvenez pas à le faire fonctionner conformément au manuel d'utilisation.
- L'équipement est tombé et a été endommagé.
- L'équipement présente des signes évidents de casse.

16. Do not place the device in an environment outside the recommended temperature range.

When using a 45W CPU, the ambient temperature should not be lower than -10°C (14°F) or higher than 55°C (131°F).

When using a 65W CPU, the ambient temperature should not be lower than -10°C (14°F) or higher than 45°C (113°F).

Exceeding these limits may cause device malfunction or damage.

Ne placez pas l'appareil dans un environnement dépassant la plage de température recommandée.

Avec un processeur de 45W, la température ambiante ne doit pas être inférieure à -10°C (14°F) ni supérieure à 55°C (131°F).

Avec un processeur de 65W, la température ambiante ne doit pas être inférieure à -10°C (14°F) ni supérieure à 45°C (113°F).

Le non-respect de ces limites peut entraîner un dysfonctionnement ou un endommagement de l'appareil.

17. CAUTION: DANGER OF EXPLOSION IF BATTERY IS INCORRECTLY REPLACED. REPLACE ONLY WITH THE SAME OR EQUIVALENT TYPE RECOMMENDED BY THE MANUFACTURER, DISCARD USED BATTERIES ACCORDING TO THE MANUFACTURER'S INSTRUCTIONS.

ATTENTION : RISQUE D'EXPLOSION SI LA BATTERIE EST MAL REMPLACÉE. REMPLACER UNIQUEMENT PAR LE MÊME TYPE OU ÉQUIVALENT RECOMMANDÉ PAR LE FABRICANT, JETER LES BATTERIES USÉES SELON LES INSTRUCTIONS DU FABRICANT.

18. In accordance with the IEC 704-1:1982 specifications, the sound pressure level at the operator position does not exceed 70 dB (A).

Conformément aux spécifications CEI 704-1:1982, le niveau de pression acoustique au poste de l'opérateur ne dépasse pas 70 dB (A).

19. DISCLAIMER: These instructions are provided according to IEC 704-1. Advantech disclaims all responsibility for the accuracy of any statements contained herein.

AVIS DE NON-RESPONSABILITÉ : Ces instructions sont fournies conformément à la norme CEI 704-1. Advantech décline toute responsabilité quant à l'exactitude des déclarations contenues dans le présent document.

20. This product is intended to be supplied by a UL listed (Certificate) power supply with a mating connector, output rated 24Vdc, 9.58A, Tma 55 degree C minimum and altitude 2000m. If need further assistance, please contact manufacture or UL File owner or brand owner for additional information.

Ce produit est destiné à être alimenté par une alimentation homologuée UL (certificat) avec un connecteur homologue, sortie nominale 24 Vdc, 9,58 A, Tma 55 degrés C minimum et altitude 2 000 m. Si vous avez besoin d'aide supplémentaire, veuillez contacter le fabricant, le propriétaire du fichier UL ou le propriétaire de la marque pour plus d'informations.

21. The equipment power supply cord shall be connected to a socket-outlet with earthing connection.

Le cordon d'alimentation de l'équipement doit être connecté à une prise de courant avec connexion à la terre.

## Safety Precaution - Static Electricity

For Skilled person follow these simple precautions to protect yourself from harm and the products from damage.

- To avoid electrical shock, always disconnect the power from your PC chassis before you work on it. Don't touch any components on the CPU card or other cards while the PC is on.
- Disconnect power before making any configuration changes. The sudden rush of power as you connect a jumper or install a card may damage sensitive electronic components.

# Content

<b>Chapter 1</b>	<b>General Information .....</b>	<b>1</b>
1.1	Introduction .....	2
1.2	Specifications .....	2
1.2.1	General .....	2
1.2.2	System Hardware.....	2
1.2.3	Certification and Environment.....	3
1.2.4	Power .....	3
1.3	External I/O.....	4
1.4	LCD & Touch Specification .....	5
	Table 1.1: Specifications .....	5
	Table 1.2: Specifications .....	6
1.5	Dimensions .....	10
1.6	LED Indicators on Optional FPM-Display.....	12
<b>Chapter 2</b>	<b>System Setup.....</b>	<b>13</b>
2.1	Transport and Unpacking .....	14
2.1.1	Transport .....	14
2.2	System Setup .....	14
2.2.1	Heatsink Removal .....	14
	Figure 2.1 Heatsink Removal .....	14
2.2.2	CPU, RAM1, M.2 Storage1 Installation.....	15
	Figure 2.2 CPU, RAM1, M.2 Storage1 Location .....	15
	Figure 2.3 Thermal Pads Installation.....	15
	Figure 2.4 Top View of Thermal Pads Installation .....	16
	Figure 2.5 Side View for PCIe Card Installation .....	16
2.2.3	(Optional) RAM2 Installation .....	17
	Figure 2.6 Bottom View of RAM Cover Removal .....	17
	Figure 2.7 Bottom View of RAM Position .....	17
	Figure 2.8 Bottom View of RAM Thermal Pad Position.....	18
	Figure 2.9 Bottom View of RAM Cover Install .....	18
2.2.4	(Optional) M.2 SATA and M.2 Wifi Module Installation .....	18
	Figure 2.10 Bottom View of M.2 Cover Installation .....	19
	Figure 2.11 Bottom View of M.2 SATA & Wi-Fi Position .....	19
	Figure 2.12 Bottom View of M.2 Thermal Pad Position.....	20
	Figure 2.13 Bottom View of M.2 Thermal Pad Position.....	20
	Figure 2.14 Bottom View of M.2 Cover Installation .....	21
2.2.5	Remove the Board-to-Board Connector Cover.....	21
	Figure 2.15 Bottom View of B2B Cover Removal .....	21

2.2.6	PCIe Cards Installation, Wi-Fi Antenna Cable Installation, and Coin Battery Replacement / CMOS Clear.....	22
	Figure 2.16 L-Shape Side Door Removal .....	22
	Figure 2.17 FAN, RTC, POE Connector Position.....	23
	Figure 2.18 Side View for Antenna Cable Opening.....	23
	Figure 2.19 L-Shape Side Door with Wi-Fi Antenna Knockout .....	24
	Figure 2.20 L-Shape Side Door with Fan Kit Installation .....	24
	Figure 2.21 L-Shape Side Door without Fan Kit Installation .....	25
2.2.7	Installing TPC-B620 with FPM-D or FPM-S Display Modules .....	25
	Figure 2.22 Attaching the TPC to the FPM Display.....	25
	Figure 2.23 Power Connector and Pin Assignment.....	26
	Figure 2.24 Power Connector.....	26
2.3	Driver Installation.....	27
2.3.1	Chipset, Graphics, ME, and LAN Driver Installation.....	27
2.3.2	Watchdog Driver Installation .....	27
2.4	Cabinet Installation and Earth Grounding Setup.....	29
2.4.1	Installing TPC into Cabinet. ....	29
	Figure 2.25 Cabinet Installation.....	29
2.4.2	System Wiring .....	30
	Figure 2.26 System Wiring .....	30
2.5	Panel Mounting.....	31
	Figure 2.27 Panel Mounting (1).....	31
	Figure 2.28 Panel Mounting (2).....	31
	Figure 2.29 Panel Mounting (3).....	32
2.6	Expansion Module Installation.....	32
2.6.1	Expansion Cover Removal .....	32
	Figure 2.30 Remove L-Shape Side Door .....	32
2.6.2	Installation of 2.5" SATA SSD .....	33
	Figure 2.31 Fix 2.5" SSD on Expansion Bracket.....	33
	Figure 2.32 Slide in Expansion Bracket .....	33
	Figure 2.33 Front View for Slide in Expansion Bracket.....	33
	Figure 2.34 Side View for Expansion Bracket .....	34
	Figure 2.35 Install L-Shape Side Door .....	34
2.6.3	Installation of Remote Button.....	35

## **Chapter 3 BIOS Setup..... 36**

3.1	BIOS Setup.....	37
3.2	Entering Setup.....	38
3.2.1	Main Setup .....	39
3.2.2	Advanced BIOS Features Setup.....	40
3.2.3	Chipset Configuration.....	52
3.2.4	Security .....	54

3.2.5	Boot.....	55
3.2.6	Save & Exit.....	56

## Appendix A Connectors .....57

A.1	Jumper and Connector Location .....	58
A.1.1	Board Layout.....	58
	Figure A.1 Board Placement - Top View .....	58
	Figure A.2 Board Layout - Bottom View .....	58
	Table A.1: Connector and Jumpers .....	59
A.2	Jumper Settings and Descriptions.....	59
A.2.1	CMOS Clear Function (SCMOS1) .....	59
	Table A.2: CMOS Clear Function.....	59
A.2.2	AT/ATX Select (PSON1) .....	60
	Table A.3: AT/ATX Select.....	60
A.3	Connector Pin Definition.....	60
A.3.1	Remote Button Connector (REMOTE1).....	60
	Table A.4: Remote Button Connector (REMOTE1) .....	60
A.3.2	Remote Button Connector (REMOTE2).....	61
	Table A.5: Remote Button Connector (REMOTE2) .....	61
A.3.3	POE Power Connector (POEPWR1) .....	61
	Table A.6: POE Power Connector (POEPWR1).....	61
A.3.4	RTC Battery Connector (BAT1).....	62
	Table A.7: RTC Battery Connector (BAT1) .....	62
A.3.5	Speaker Connector (SPK1) .....	62
	Table A.8: Speaker Connector (SPK1) .....	62
A.3.6	Fan Connector (SYSFAN1).....	63
	Table A.9: System Fan Connector (SYSFAN1) .....	63
A.3.7	COM1/2 RS-232/422/485 Connector (COM1&2) .....	63
	Table A.10: COM1&2 RS-232/422/485 Connector (COM1&2).....	63
A.3.8	Power Input Connector (DCIN1).....	64
	Table A.11: Power Input Connector (DCIN1).....	64
A.3.9	iDoor Power Connector (DCOUT1) .....	64
	Table A.12: iDoor Power Connector (DCOUT1).....	64
A.3.10	M.2 M-Key Connector (M2-M1) .....	65
	Table A.13: M.2 M-Key Connector (M2-M1) .....	65
A.3.11	M.2 M-Key Connector (M2-M2) .....	66
	Table A.14: M.2 M-Key Connector (M2-M2) .....	66
A.3.12	M.2 B-Key Connector (M2-M3).....	67
	Table A.15: M.2 B-Key Connector (M2-M3).....	67
A.3.13	M.2 B-Key Connector (M2-E1).....	68
	Table A.16: M.2 B-Key Connector (M2-E1) .....	68

**Appendix B Driver Installation .....70**

- B.1 Intel Chipset Device Software Installation .....71
- B.2 Intel Management Engine Components Installation.....73
- B.3 Intel Graphics Driver Installation .....74
- B.4 Intel LAN Driver Installation .....76
- B.5 Audio Driver Installation .....77
- B.6 Intel GNA Driver Installation .....78



# Chapter 1

General Information

---

## 1.1 Introduction

The TPC-B620 series is a computing box module equipped with Intel® R680E and H610E Chipset.

- High Performance Computing Box powered by Intel® 12th/13th/14th Gen. Core™ i / BTL Core™ S-series CPUs Socket (LGA1700) with fanless design
- 10+ x Panel Modules (IP66) ranging from 15" to 23.8" in selection
- Dual Channel DDR5 memory slot supports up to 64GB in total
- Comprehensive I/Os, including 4 x USB, 2 x COM, 3 x RJ45...etc
- (Optional) Supports PCIe Expansion via:  
(R680E) 1 x PCIe x16 + 1 x PCIe x4 or 1 x PCIe x4 + 1 x PCIe x4  
(H610E) 1 x PCIe x16 + 1 x PCIe x2 or 1 x PCIe x2
- Supports Storage via 2 x M.2 2280 SATA SSD (RAID 0/1), 1 x M.2 NVMe, (Optional) 1 x 2.5" SATA SSD
- Support fieldbus protocols/ GPS/ GPRS/ Wi-Fi capabilities via iDoor technology
- Supports TPM 2.0 hardware security

## 1.2 Specifications

### 1.2.1 General

- **BIOS:** AMI UEFI
- **Cooling System:** Fanless design
- **Dimensions (W x H x D):** 269 x 224 x 76 mm (10.59 x 8.82 x 2.99 inch)
- **Enclosure:**  
Back housing: Aluminum housing
- **Mounting:** VESA mount (100 x 100), desktop, wall or panel mount
- **OS Support:** Windows 11, Windows 10, Linux
- **Security:** TPM 2.0 (built-in)
- **Watchdog Timer:** 15-255 sec (system)
- **Weight (Net):** 4.27 kg (9.41 lb)

### 1.2.2 System Hardware

- **CPU:**  
Selectable Intel® 12th/13th/14th Gen. processors/ BTL Core™ S-series CPUs Socket (LGA1700)
- **Chipset:**  
Intel® R680E and H610E
- **Memory:**  
Dual Channel DDR5 SO-DIMM up to 32 GB, 64GB in total
- **LAN Port:** 3 x 2.5GbE with Intel® I226
- **Storage:**  
1 x M.2 M key 2280 for NVMe (PCIe x4 / SATA)  
2 x M.2 M key 2280 (SATA)  
(Optional) 1 x SATA for 2.5" SSD/HDD

- **(Optional) PCIe Expansion Slots:**  
(R680E GPU SKU) 1 x PCIe x16 + 1 x PCIe x4  
(H610E GPU SKU) 1 x PCIe x16 + 1 x PCIe x2  
(R680E IO card SKU) 1 x PCIe x4 + 1 x PCIe x4  
(H610E IO card SKU) 1 x PCIe x2
- **Expansion Slot:**  
1 x M.2 E key 2230 (WIFI, PCIe x1/USB 2.0)
- **I/O Ports:**  
2 x RS-232/422/485  
4 x USB 3.2 (Gen 1)  
1 x Displayport 1.2  
1 x HDMI 1.4a  
1 x Audio line out/Mic in

### 1.2.3 Certification and Environment

#### Certification

- BSMI
- CCC
- CE
- FCC Class A
- CB/UL
- IP66-rated front panel

#### Environment

- **Operating Temperature:**  
35W/45W CPU: -10~55 °C (14~131 °F) (w/ 0.7 m/s airflow)  
65W CPU: -10~45 °C (14~113 °F) (w/ 0.7 m/s airflow)
- **Storage Temperature:** -20 ~ 70 °C (-22 ~ 158 °F)
- **Humidity:** 95% RH @ 40 °C, non-condensing
- **Vibration Protection:** 1 Grms random vibration (5 ~ 500 Hz) during operation (with SSD)

### 1.2.4 Power

- **Input Voltage:** 24V<sub>DC</sub> ± 20%
- **Power Consumption:** Typ. 85W; Max. 195W

## 1.3 External I/O

The arrangement of I/O ports is shown below.

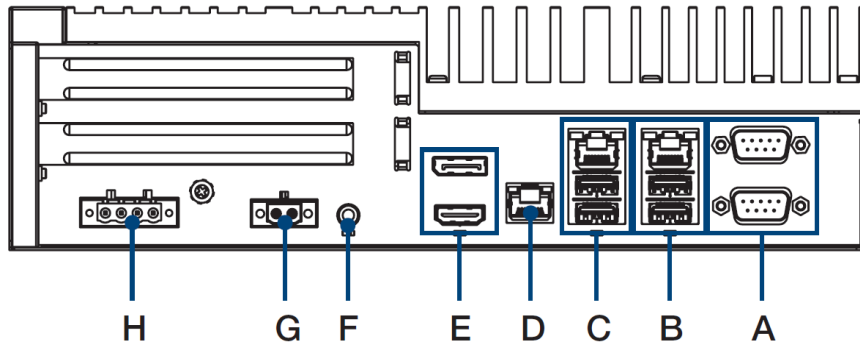

A. COM1,2 (RS-232/422/485)

B. 2.5 GbE LAN / USB 3.2 x2

C. 2.5 GbE LAN / USB 3.2 x2

D. 2.5 GbE LAN

E. 1 x DP / 1 x HDMI

F. Audio line out/Mic in

G. Remote button connector

H. DC IN Connector

## 1.4 LCD & Touch Specification

**Table 1.1: Specifications**

Part Number for Cost Effective Version		FPM-D15T-CE	FPM-D17T-CE	FPM-D19T-CE
LCD Panel	Display Size	15"	17"	19"
	Display Type	XGA TFT LED	SXGA TFT LED	SXGA TFT LED
		LCD	LCD	LCD
	Aspect Ratio	4:3	5:4	5:4
	Max. Resolution	1024 x 768	1280 x 1024	1280 x 1024
	Max. Color	16.7M	16.7M	16.7M
	Luminance	300 cd/m <sup>2</sup>	350 cd/m <sup>2</sup>	350 cd/m <sup>2</sup>
	Viewing Angle (H/V)	176°/176°	160°/140°	170°/160°
		Backlight Life	70,000 hr	50,000 hr
	Contrast Ratio	2000:1	800:1	1000:1
Touchscreen	Type	PCAP	PCAP	PCAP
	Light Transmis- sion	Above 88%	Above 88%	Above 88%
	Anti-Glare Treatment	Yes	Yes	Yes
Environment	Operating Temperature	-20~60 °C (-4~140 °F)	-20~60 °C (-4~140 °F)	-20~60 °C (-4~140 °F)
	Storage Temperature	-30~70 °C (-22~158 °F)	-30~70 °C (-22~158 °F)	-30~70 °C (-22~158 °F)
	Ingress Protection	Font IP66	Font IP66	Font IP66
	Housing Color Panel Frame and Back Cover	Pantone 432C	Pantone 432C	Pantone 432C

**Table 1.2: Specifications**

Part Number for Cost Effective Version	FPM-D15W- FCE	FPM-D18W- FCE	FPM-D21W- CE	FPM-D24W- CE	
LCD Panel	Display Size	15.6"	18"	21.5"	23.8"
	Display Type	FHD TFT LED LCD	FHD TFT LED LCD	FHD TFT LED LCD	FHD TFT LED LCD
	Aspect Ratio	16:9			
	Max. Resolution	1920 x 1080	1920 x 1080	1920 x 1080	1920 x 1080
	Max. Color	16.7M	16.7M	16.7M	16.7M
	Luminance	450 cd/m <sup>2</sup>	350 cd/m <sup>2</sup>	250 cd/m <sup>2</sup>	350 cd/m <sup>2</sup>
	Viewing Angle (H/V)	170°/170	178°/178°	178°/178°	178°/178°
	Backlight Life	50,000 hr	50,000 hr	50,000 hr	30,000hr
	Contrast Ratio	800:1	1000:1	1000:1	1000:1
	Touchscreen	Type	PCAP	PCAP	PCAP
Light Transmis- sion		Above 88%	Above 85%	Above 88%	90%±3%
Anti-Glare Treatment		Yes	Yes	Yes	Yes
Environment	Operating Temperature	-20~60 °C (-4~140 °F)	-20~60 °C (-4~140 °F)	0~55 °C (32~131 °F)	0~55 °C (32~131 °F)
	Storage Temperature	-30~70 °C (-22~158 °F)	-30~70 °C (-22~158 °F)	-20~60 °C (-4~140 °F)	-20~60 °C (-4~140 °F)
	Ingress Protection	Font IP66	Font IP66	Font IP66	Font IP66
	Housing Color	Panel Frame and Back Cover	Pantone 432C	Pantone 432C	Pantone 432C

**Table 1.3: Specifications**

Part Number for Cost Effective Version		FPM-D15T-HE	FPM-D15W-FHE	FPM-D21W-HE	
LCD Panel	Display Size	15.6"	15.6"	21.5"	
	Display Type	FHD TFT LED	FHD TFT LED	FHD TFT LED	
		LCD	LCD	LCD	
	Aspect Ratio	16:9	16:9	16:9	
	Max. Resolution	1024 x 768	1920 x 1080	1920 x 1080	
	Max. Color	16.2M	16.7M	16.7M	
	Luminance	1,800 cd/m <sup>2</sup>	1,200 cd/m <sup>2</sup>	1,400 cd/m <sup>2</sup>	
	Viewing Angle (H/V)	160°/150°	178°/178°	178°/178°	
		Backlight Life	50,000 hr	50,000 hr	50,000hr
	Contrast Ratio	800:1	800:1	1000:1	
Touchscreen	Type	PCAP	PCAP	PCAP	
	Light Transmis- sion	Above 85%	Above 88%	Above 88%	
		Anti-Glare Treatment	Yes	Yes	Yes
Environment	Operating Temperature	-20~60 °C (-4~140 °F)	-20~60 °C (-4~140 °F)	-20~60 °C (-4~140 °F)	
	Storage Temperature	-30~70 °C (-22~158 °F)	-30~70 °C (-22~158 °F)	-30~70 °C (-22~158 °F)	
	Ingress Protection	Font IP66	Font IP66	Font IP66	
	Housing Color	Panel Frame and Back Cover	Pantone 432C	Pantone 432C	Pantone 432C

**Table 1.4: Specifications**

Part Number for Cost Effective Version		FPM-D15T-RE	FPM-D17T-RE
LCD Panel	Display Size	15"	17"
	Display Type	XGA TFT LED LCD	SXGA TFT LED LCD
	Aspect Ratio	4:3	5:4
	Max. Resolution	1024 x 768	1280 x 1024
	Max. Color	16.7M	16.7M
	Luminance	300 cd/m <sup>2</sup>	350 cd/m <sup>2</sup>
	Viewing Angle (H/V)	176°/176°	160°/140°
	Backlight Life	70,000 hr	50,000 hr
	Contrast Ratio	2000:1	800:1
Touchscreen	Type	5-Wire Resistive	5-Wire Resistive
	Light Transmis- sion	81% ±3%	81% ±3%
	Anti-Glare Treatment	Yes	Yes
Environment	Operating Temperature	-20~60 °C (-4~140 °F)	-20~50 °C (-4~122 °F)
	Storage Temperature	-30~70 °C (-22~158 °F)	-30~60 °C (-22~140 °F)
	Ingress Protection	Font IP66	Font IP66
	Housing Color Panel Frame and Back Cover	Pantone 432C	Pantone 432C

**Table 1.5: Specifications**

Part Number for Cost Effective Version		FPM-S18W-A	FPM-S21W-A
LCD Panel	Display Size	18.5"	21.5"
	Display Type	FHD TFT LED LCD	FHD TFT LED LCD
	Aspect Ratio	16:9	16:9
	Max. Resolution	1920 x 1080	1920 x 1080
	Max. Color	16.7M	16.7M
	Luminance	350 cd/m <sup>2</sup>	250 cd/m <sup>2</sup>
	Viewing Angle (H/V)	170°/160°	178°/178°
	Backlight Life	50,000 hr	50,000 hr
	Contrast Ratio	1000:1	1000:1
Touchscreen	Type	PCAP	PCAP
	Light Transmis- sion	Above 90%	Above 90%
	Anti-Glare Treatment	Yes	Yes
Environment	Operating Temperature	-10~60 °C (14~140 °F)	0~55 °C (32~131 °F)
	Storage Temperature	-20~60 °C (-4~140 °F)	-20~60 °C (-4~140 °F)
	Ingress Protection	Font IP66	Font IP66
	Housing Color Panel Frame and Back Cover	Pantone 432C	Pantone 432C



### FPM-D Display Module

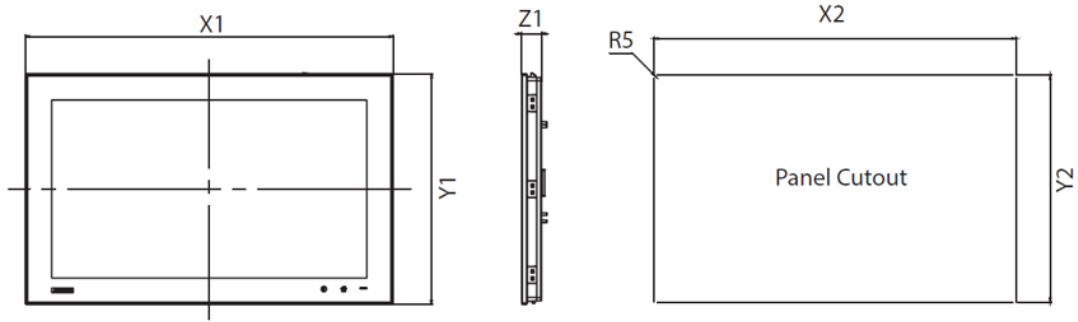

Display Type	System Dimensions			Panel Mount	
	X1	Y1	Z1	X2	Y2
15" (XGA)	383.2	307.3	27.5	374.5	298.5
15.6" (HD)	419.7	269	30.	412.4	261.7
15.6" (FHD)	419.7	269	30.	412.4	261.7
17" (SXGA)	410.4	343.4	28.3	401.3	334.8
18.5" (HD / FHD)	488	309	30.3	479.3	300.3
19" (SXGA)	454	379.8	51.5	443.5	369.3
21.5" (FHD)	558.4	349.8	30.3	550.3	341.8
23.8" (FHD)	595.9	374.1	30.3	587	365.3

(Unit: mm)

### FPM-S Display Module

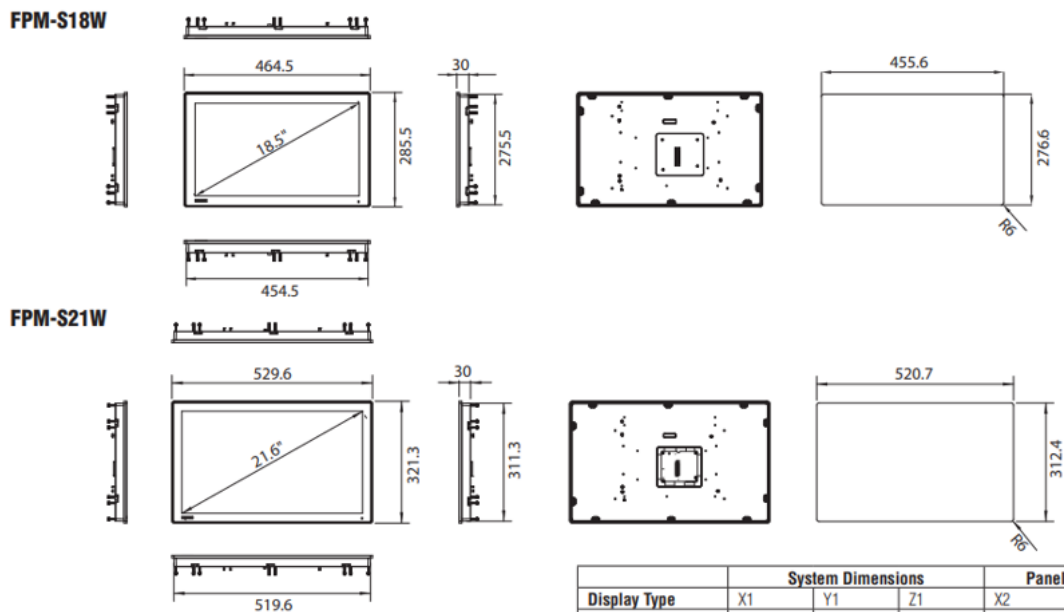

Display Type	System Dimensions			Panel Mount	
	X1	Y1	Z1	X2	Y2
18.5" (FHD)	464.5	285.5	30	455.6	276.6
21.5" (FHD)	529.6	321.3	30	520.7	312.4

(Unit: mm)

## 1.6 LED Indicators on Optional FPM-Display

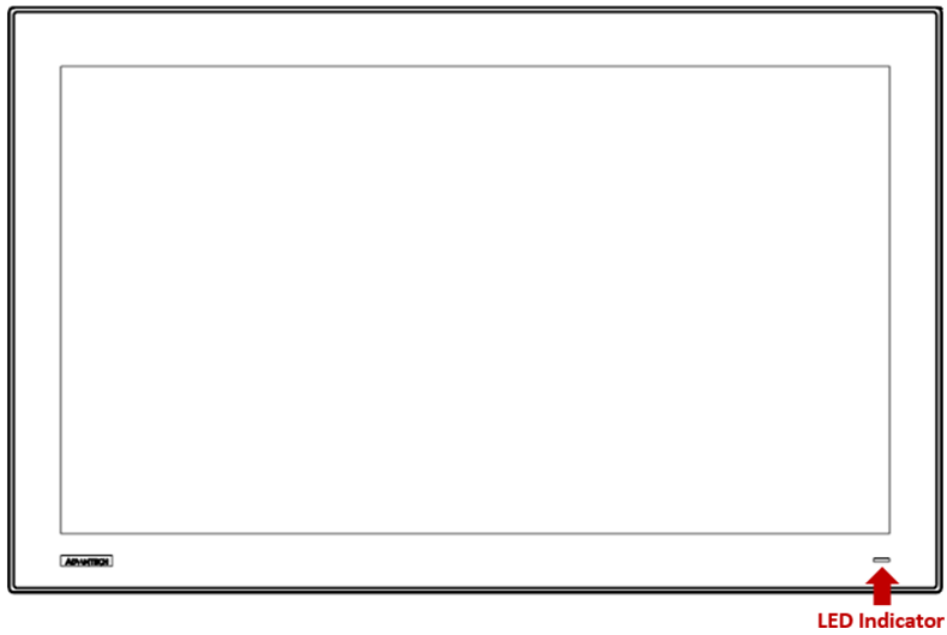

Indicator	Default Status (ErP Enable)	Status 2 (ErP Disable)
Green	Normal Powered-On State	Normal Powered-On State
Orange	Sleep (S3) / Hibernate (S4)	Sleep (S3) / Hibernate (S4) / Shutdown(S5)
No Light	Shutdown(S5)/Power Off	Power Off

# Chapter 2

## System Setup

## 2.1 Transport and Unpacking

### 2.1.1 Transport

When accepting a delivery, please check the packaging for visible transport damage and check the delivery for completeness by comparing it with your order. If you notice any shipping damage or inconsistencies between the contents and your order, please inform the responsible delivery service immediately.

During transportation, the TPC should be protected from excessive mechanical stress. If the TPC is transported or stored without packaging, shocks, vibrations, pressure and moisture may impact the unprotected unit. A damaged packaging indicates that ambient conditions have already had a massive impact on the device. Therefore, please use the original packaging during transportation and storage.

If the TPC is transported in cold weather or is exposed to extreme variations in temperature, make sure that moisture (condensation) does not build up on or inside the HMI device. Moisture can result in short-circuits in electrical circuits and damage the device. To avoid that, please store the TPC in a dry place and bring the TPC to room temperature before starting it up. If condensation occurs, a delay time of approximately 12 hours must be allowed to make sure the TPC is completely dry before the TPC is switched on.

## 2.2 System Setup

### 2.2.1 Heatsink Removal

Follow these steps to setup the TPC-B620 device:

1. Unbox the TPC-B620 device
2. Remove heatsink: Detach the heatsink from the chassis by loosening the 12 screws.

**Important:** Pay special attention to the four screws located around the CPU area. These screws are positioned deeper, so you must use the longer screws when removing and re-attaching them.

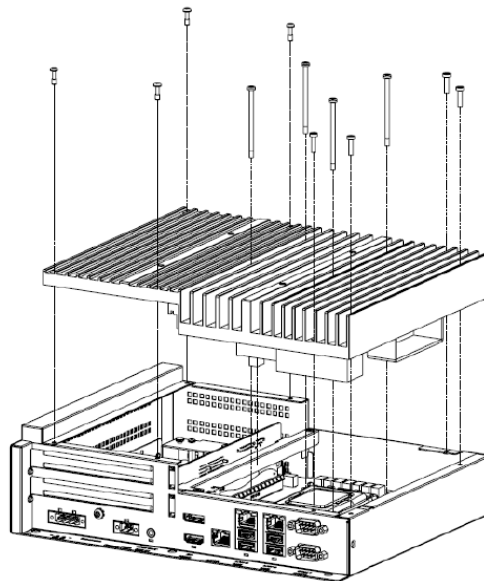

Figure 2.1 Heatsink Removal

## 2.2.2 CPU, RAM1, M.2 Storage1 Installation

1. Please follow Figure 2.2 to install CPU, RAM1 and M.2 Storage 1 for TPC-B620. Detach the purchased TPC-B620H-DIOA1/TPC-B620R-DIOA1 or TPC-B620-DGUA1 module, then install the PCIe daughter board securely.

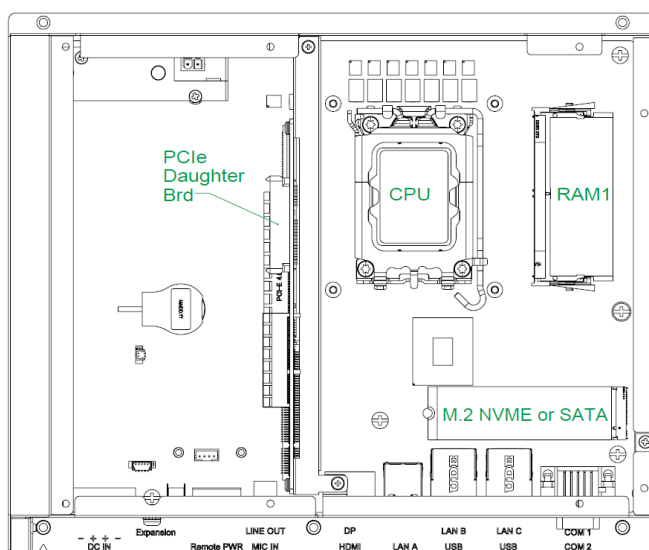

Figure 2.2 CPU, RAM1, M.2 Storage1 Location

2. Place the CPU thermal pad, PCH thermal pad, VR thermal pad, RAM thermal pad, and NVMe thermal pad onto their designated positions.
 

**Important:** Make sure each thermal pad is properly aligned and securely attached so that it makes full contact with the heatsink. Improper placement may cause overheating or system instability.

**Note (for PCIe expansion):** If you plan to install a PCIe expansion card, please complete this installation right after Step 2. Refer to section 2.2.6 **PCIe Expansion Installation** and follow those steps to install the PCIe card before proceeding further.

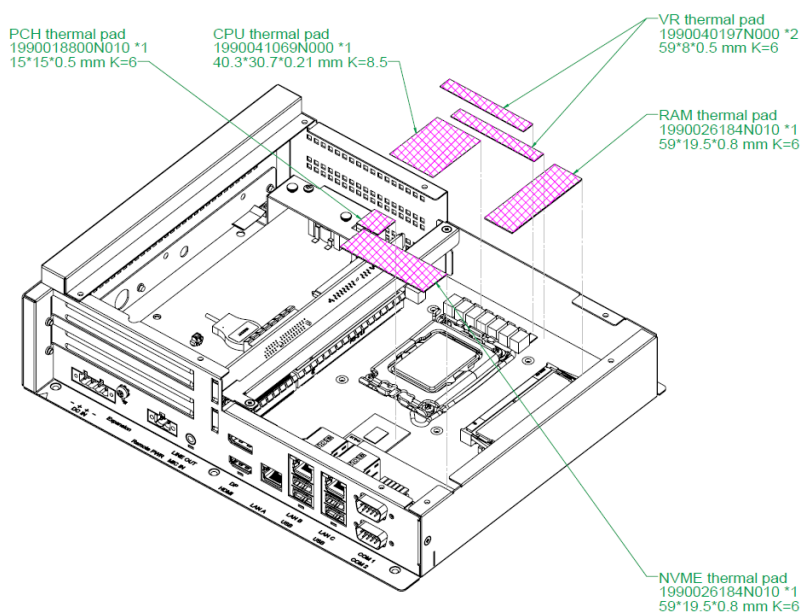
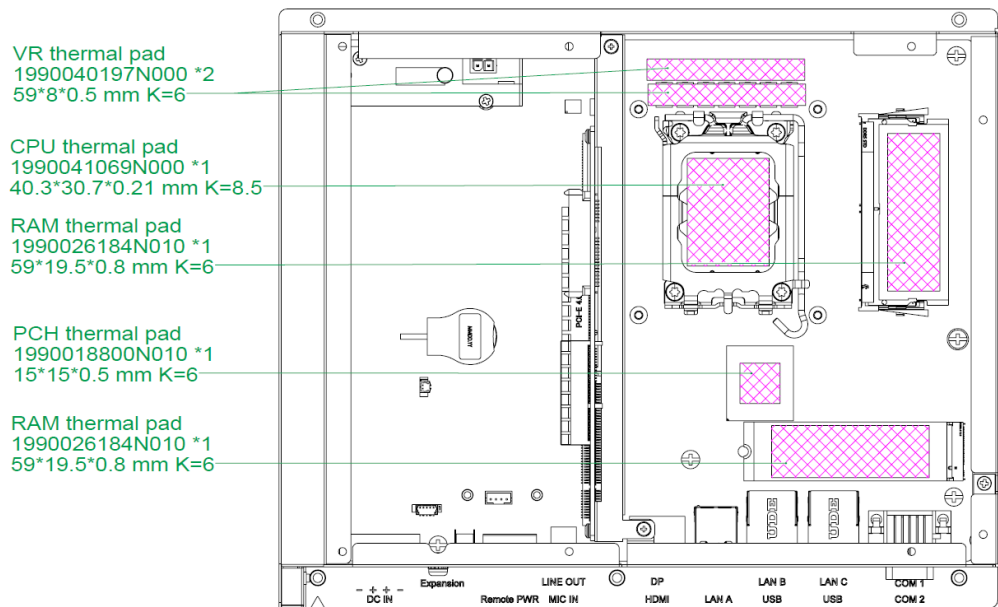

Figure 2.3 Thermal Pads Installation



**Figure 2.4 Top View of Thermal Pads Installation**

**Warning!**



*If your M.2 SSD comes with a heatsink, please remove it before installation. The TPC-B620 already includes a heatsink. Failure to remove the heatsink may lead to improper fit and cooling issues.*

*Si votre SSD M.2 est livré avec un dissipateur thermique, veuillez le retirer avant l'installation. Le TPC-B620 comprend déjà un dissipateur thermique. Ne pas retirer le dissipateur thermique peut entraîner un mauvais ajustement et des problèmes de refroidissement.*

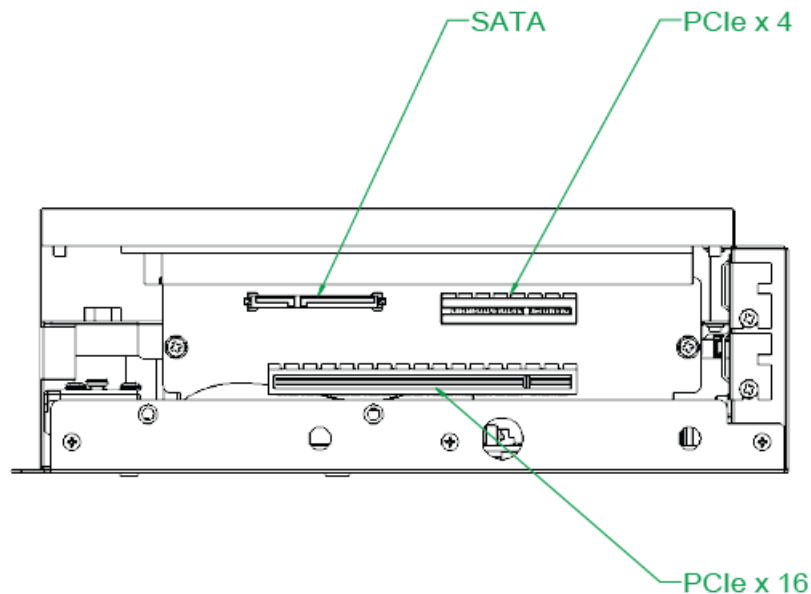

**Figure 2.5 Side View for PCIe Card Installation**

**Warning!** According to Intel guidelines, the PCIe x16 slot is intended for use only with a GPU or storage devices.  
 Conformément aux recommandations de Intel, le slot PCIe x16 est réservé exclusivement à l'installation d'un GPU ou de périphériques de stockage.



### 2.2.3 (Optional) RAM2 Installation

**Note:** This step is optional. If the customer has purchased a second RAM module, or plans for future single-RAM upgrades, it is recommended to install the RAM in this slot.

1. Turn the TPC-B620 upside down with the heatsink facing downward. Refer to the figure below and remove one screw to detach the RAM cover panel.

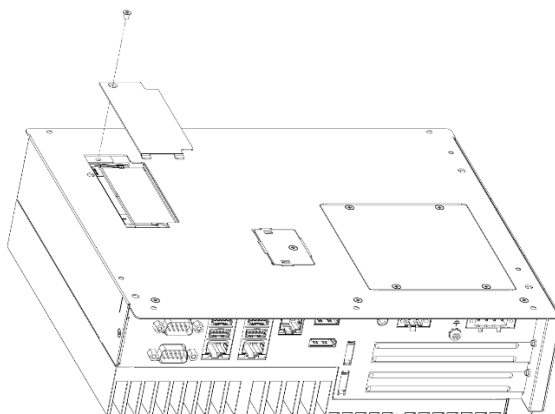

**Figure 2.6 Bottom View of RAM Cover Removal**

2. Insert the RAM module firmly into the slot.  
**Caution:** Before handling the RAM module, discharge any static electricity by touching a grounded metal surface. Avoid direct contact with the gold connectors to prevent damage.

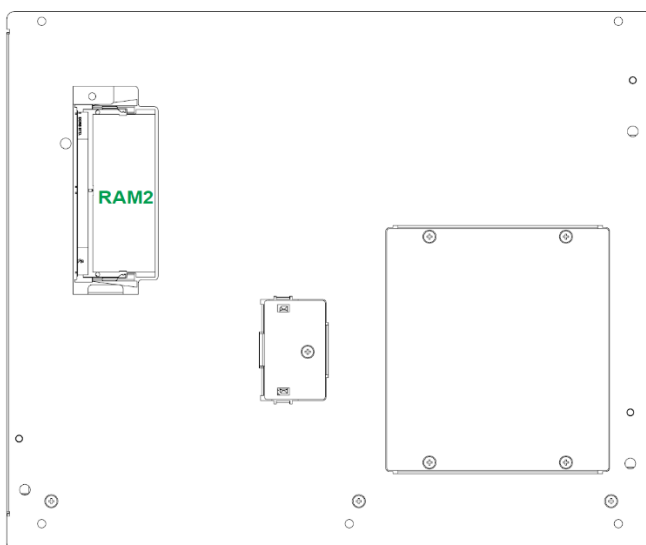

**Figure 2.7 Bottom View of RAM Position**

3. Take the RAM thermal pad from the accessory box and place it onto the RAM as shown in the figure below.

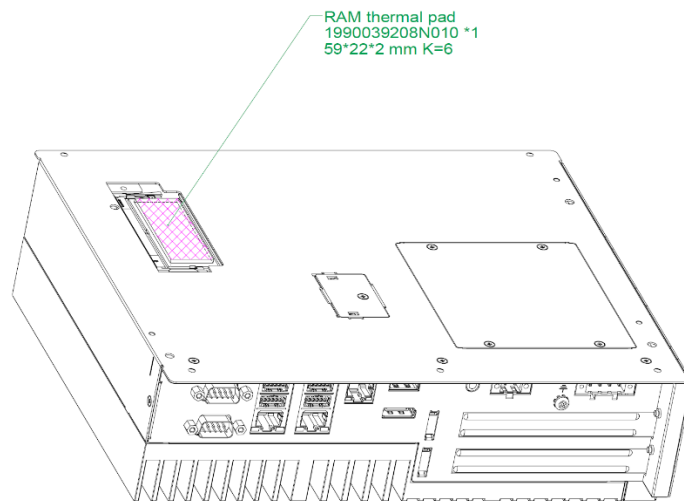

**Figure 2.8 Bottom View of RAM Thermal Pad Position**

4. Secure the cover panel back in place with the screw removed in Step 1.

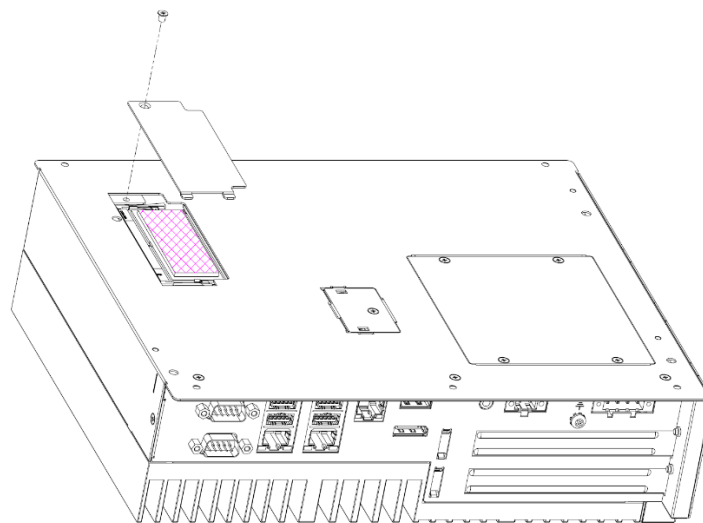

**Figure 2.9 Bottom View of RAM Cover Install**

## 2.2.4 (Optional) M.2 SATA and M.2 Wifi Module Installation

**Note:** This step is optional. If the customer has purchased a second or third M.2 SATA SSD, or an M.2 E-key Wi-Fi module, please follow the steps below.

1. Flip the TPC-B620 upside down with the heatsink facing downward. Refer to the figure below and remove four screws to detach the M.2 expansion cover panel.

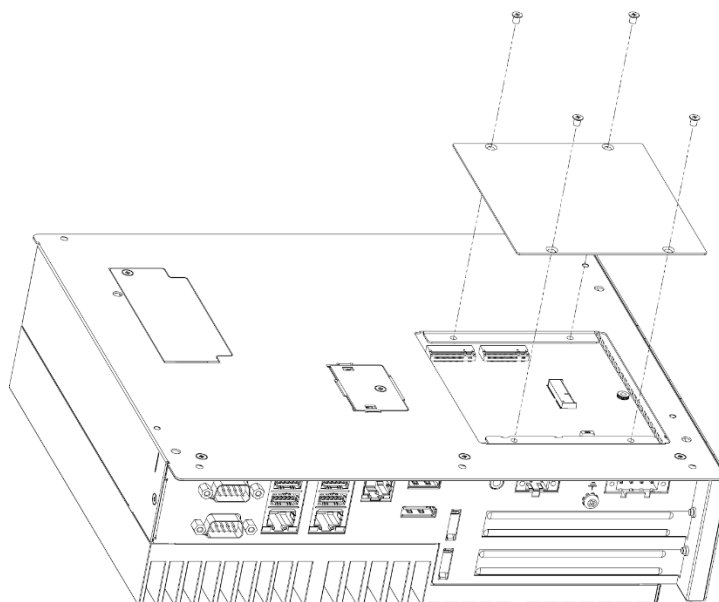

Figure 2.10 Bottom View of M.2 Cover Installation

2. Insert the M.2 SATA SSD or M.2 Wi-Fi module into the slot.  
**Caution:** Before handling the module, discharge any static electricity by touching a grounded metal surface. Avoid direct contact with the gold connectors to prevent damage.

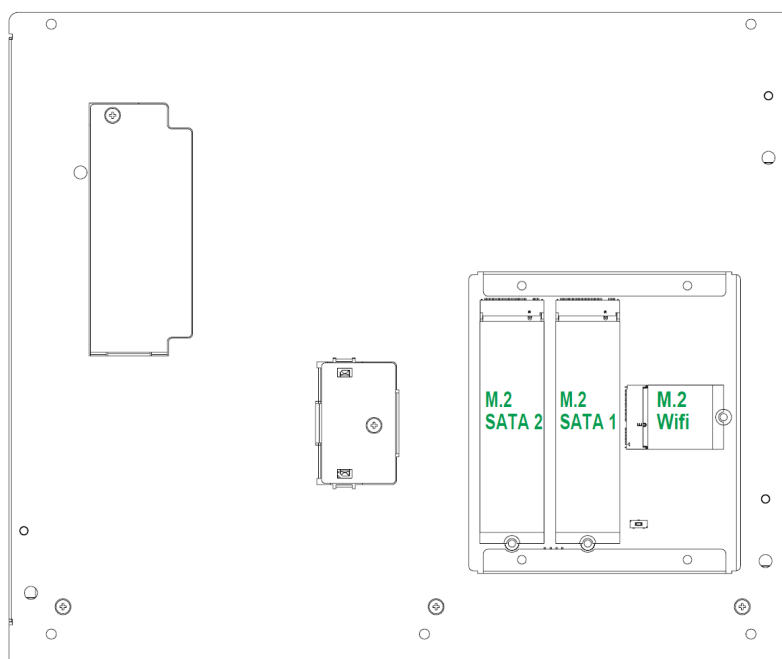
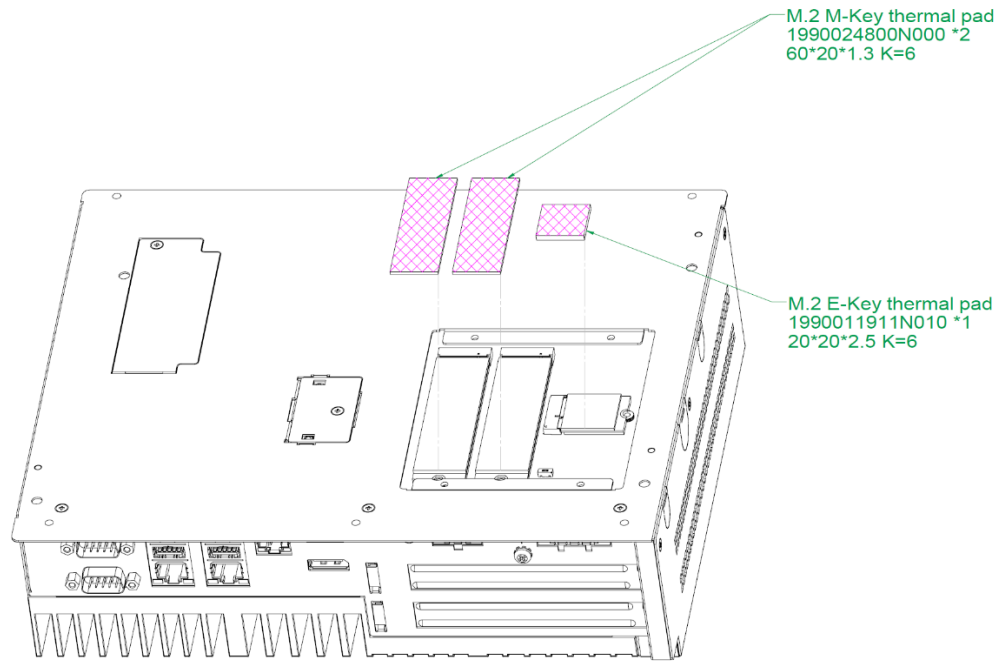
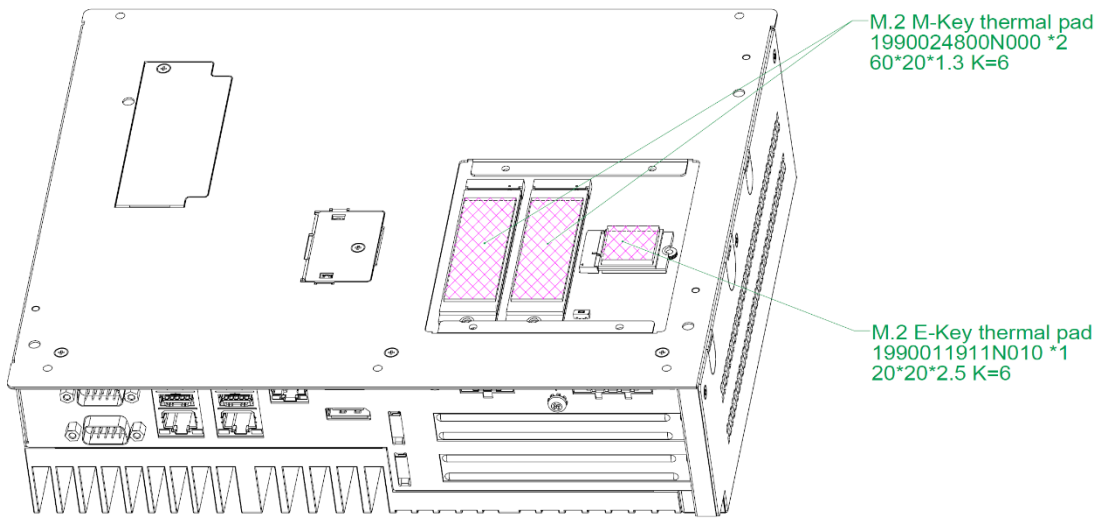

Figure 2.11 Bottom View of M.2 SATA & Wi-Fi Position

3. Take the thermal pad for the M.2 module from the accessory box and place it onto the installed device as shown in the figure below.

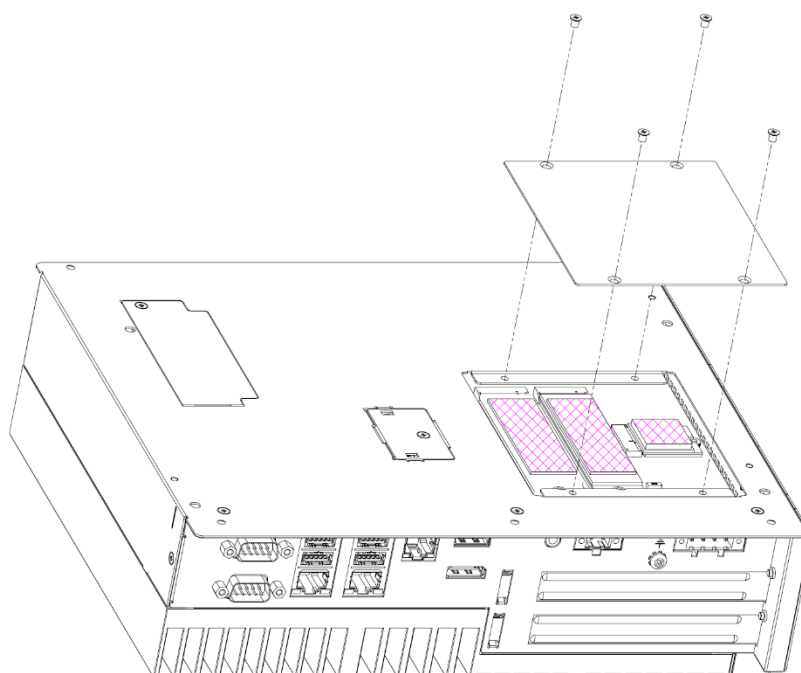

**Figure 2.12 Bottom View of M.2 Thermal Pad Position**



**Figure 2.13 Bottom View of M.2 Thermal Pad Position**

- Secure the cover panel back in place with the four screws removed in Step 1.

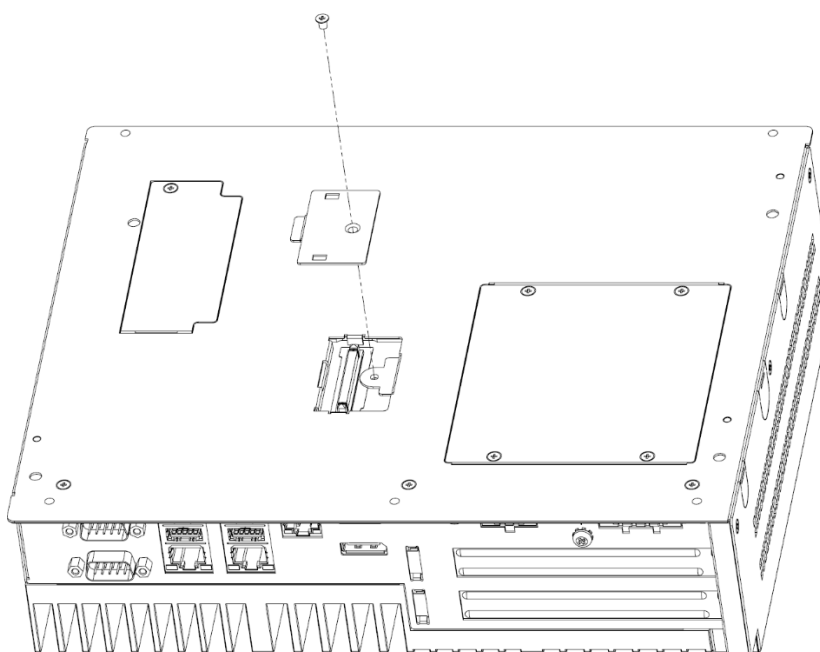

**Figure 2.14 Bottom View of M.2 Cover Installation**

### 2.2.5 Remove the Board-to-Board Connector Cover

On the bottom side of the TPC-B620, remove the cover of the board-to-board connector before connecting the device to an FPM-DXXX or FPM-SXXX product.

**Warning:** Do not attempt to connect the FPM-DXXX or FPM-SXXX product without first removing this cover. Doing so may damage the product, cause display malfunctions, or prevent proper installation.



**Figure 2.15 Bottom View of B2B Cover Removal**

## 2.2.6 PCIe Cards Installation, Wi-Fi Antenna Cable Installation, and Coin Battery Replacement / CMOS Clear

**Note:** This section describes the procedure for replacing or upgrading the PCIe card after the full system has been assembled. However, if you already know which PCIe card will be installed, it is recommended to perform this installation earlier (after **Step 2 in Section 2.2.2**) by following the steps below.

**Important:**

- If installing a **PoE card** or a **GPU card**, you must use the **TPC-B620-DGUA1** module to ensure the system fan is available for cooling.
- If installing a **low-power PCIe card**, the **TPC-B620-DIOA1** module can be used. This provides PCIe x4 + PCIe x4 slots. If the operating environment is excessively hot and causes system instability, please also install the **TPC-B620 FAN Kit** to ensure stable system performance.
- **Note for TPC-B610H with TPC-B620-DIOA1 module:** Only the upper PCIe x4 connector provides a PCIe x2 signal. The PCIe x16 connector has no signal—do not insert a card into this slot.

1. Unscrew the six screws from the side of the TPC-B620 and remove the L-shaped metal cover.

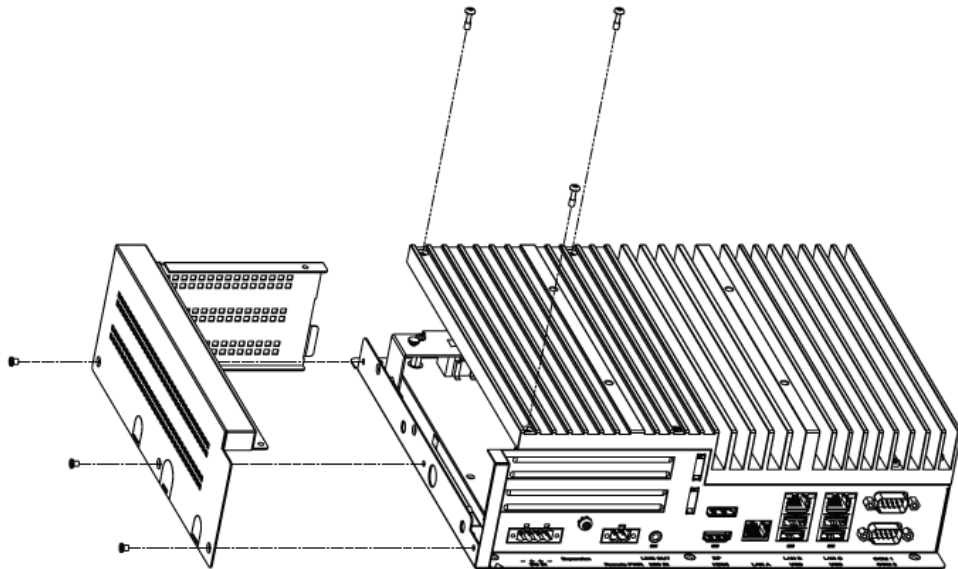

**Figure 2.16 L-Shape Side Door Removal**

2. (Optional) If you plan to add the TPC-B620-DGUA1 fan module later, make sure the card does not obstruct the **FAN connector** shown in the figure below.
3. (Optional) To replace the RTC coin battery, remove the old battery and insert the new one.

4. (Optional) To clear CMOS, press and hold the button located next to the coin battery for more than 5 seconds to ensure the CMOS is reset.

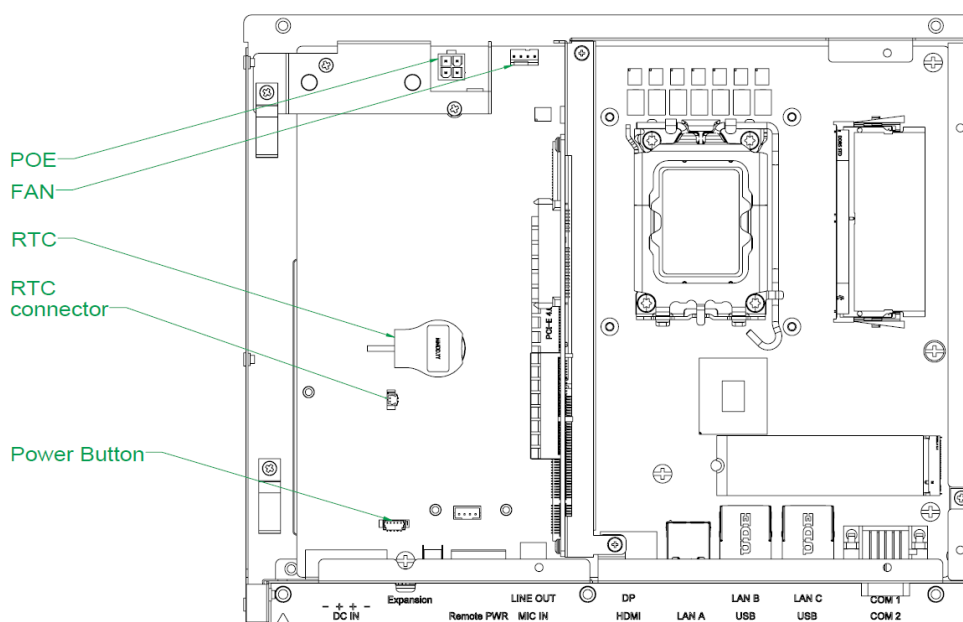

**Figure 2.17 FAN, RTC, POE Connector Position**

5. If you have purchased a Wi-Fi module, after completing Step 2 and Step 3 in Section 2.2.4, secure the internal antenna cables through the designated opening as shown in the figure.

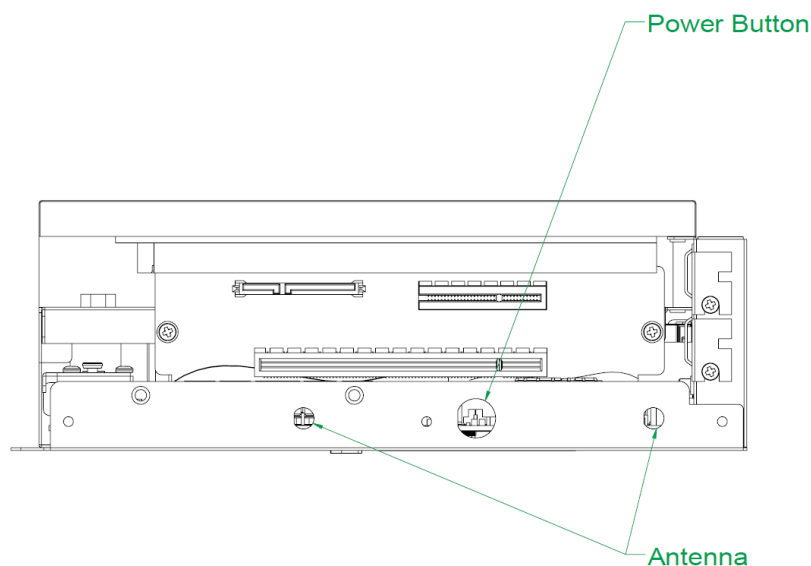

**Figure 2.18 Side View for Antenna Cable Opening**

6. (Optional) Remove knockout for Wi-Fi antenna. If a Wi-Fi module is installed, remove the knockout hole on the L-shaped cover to route the antenna cable.

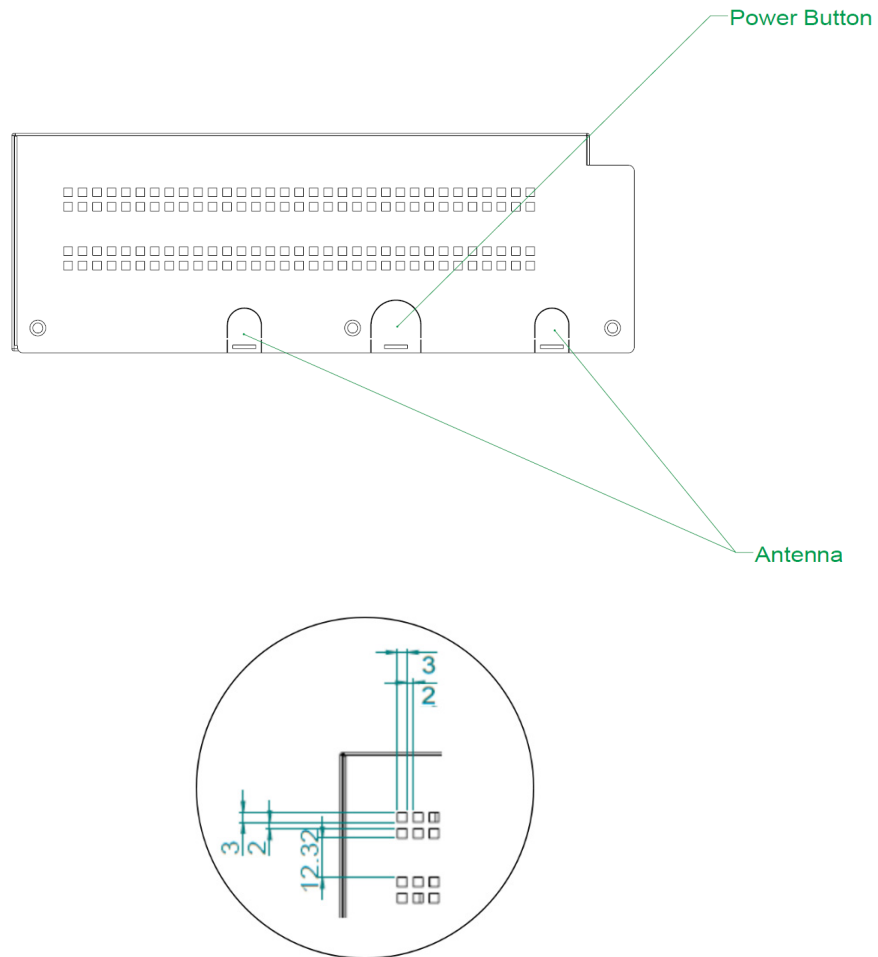

**Figure 2.19 L-Shape Side Door with Wi-Fi Antenna Knockout**

7. Reattach the cover with fan module (for GPU or POE cards).
  - If installing a GPU card, discard the original L-shaped cover removed in Step 1 of Section 2.2.6. Use the six screws to secure the new cover with fan module, and connect the fan cable to the FAN connector on the board.

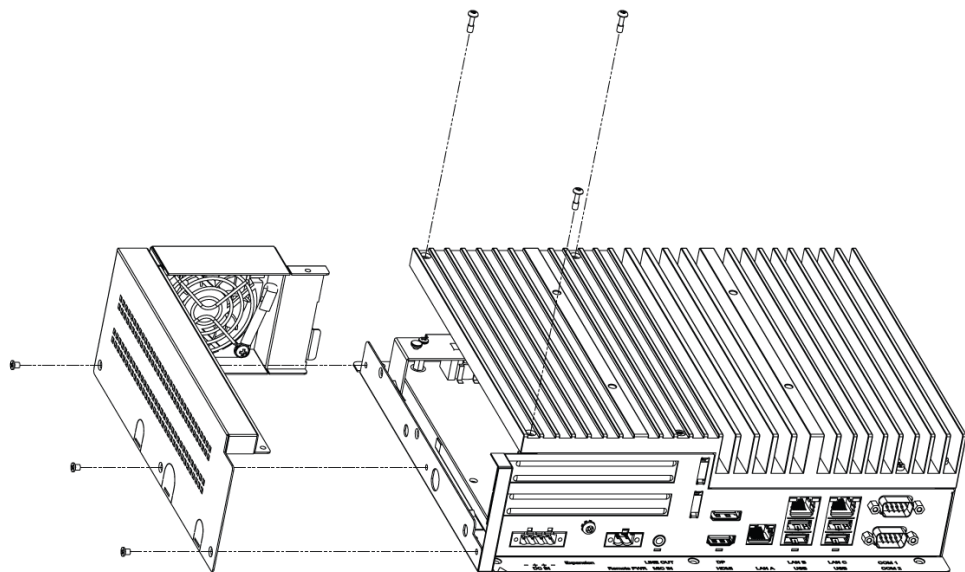

**Figure 2.20 L-Shape Side Door with Fan Kit Installation**

- If installing an I/O card, simply reinstall the original L-shaped cover.

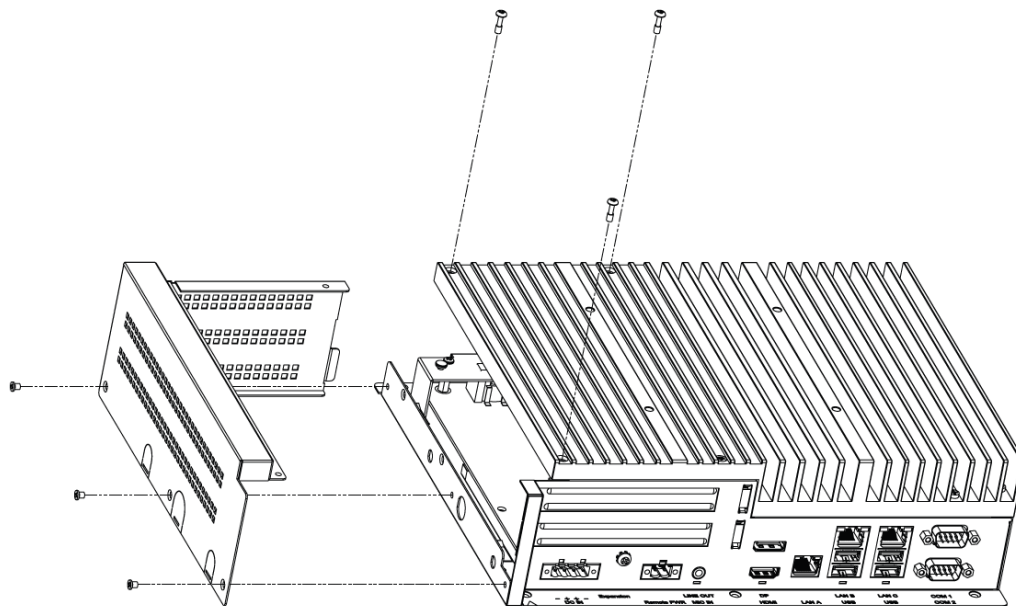

**Figure 2.21 L-Shape Side Door without Fan Kit Installation**

## 2.2.7 Installing TPC-B620 with FPM-D or FPM-S Display Modules

1. Attach the TPC computing box module to the FPM display module via the board-to-board connector. Use the five screws of 1930000881 to secure the computing box with the display module.  
1930000881 = M3, 8L Min. type

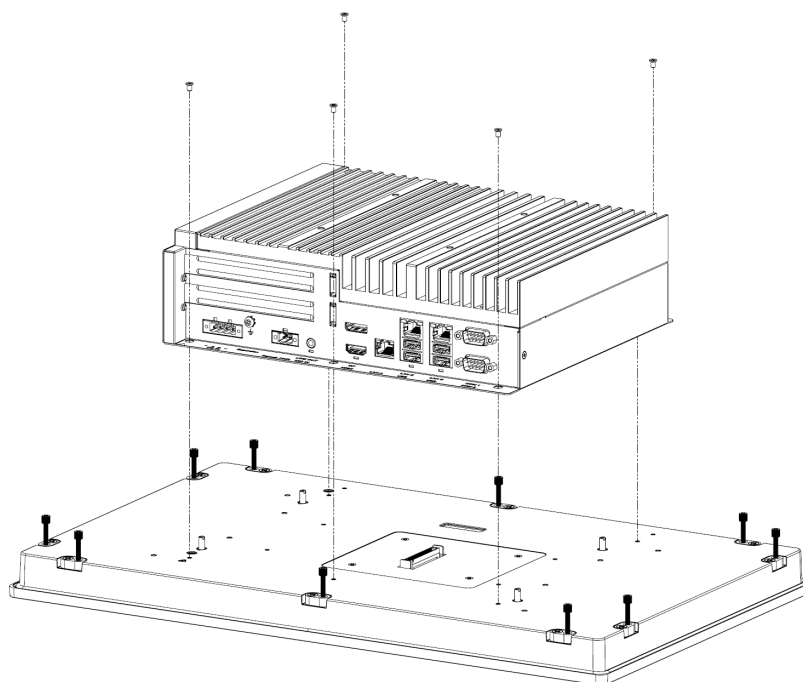

**Figure 2.22 Attaching the TPC to the FPM Display**

2. Connect the power connector to the 24 VDC power lines of a power adapter or in-house power source.

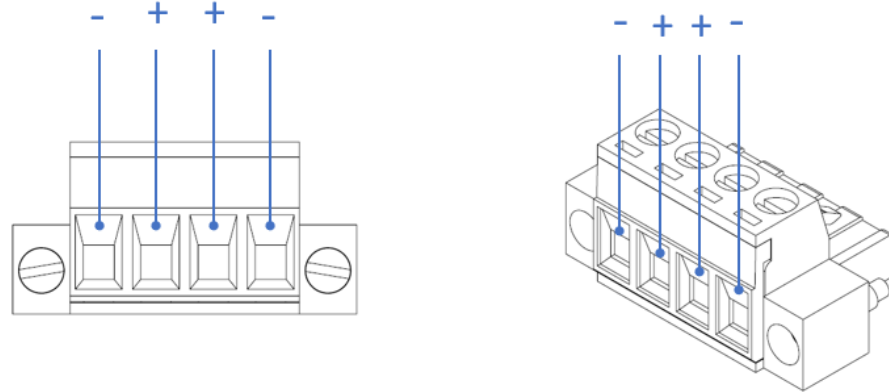

**Figure 2.23 Power Connector and Pin Assignment**

**Warning!** *The system may get damaged when the power is turned on and the power source is not connected to the correct pins.*  
 *Le système peut être endommagé lorsque l'alimentation est allumée et que la source d'alimentation n'est pas connectée aux broches appropriées.*

3. Connect the power lines to the system power receptor using the terminal block suitable for 12-24 AWG. Apply a torque value of 7 lb-in. Ensure the use of copper conductors only, and the installation must be performed by a skilled person.

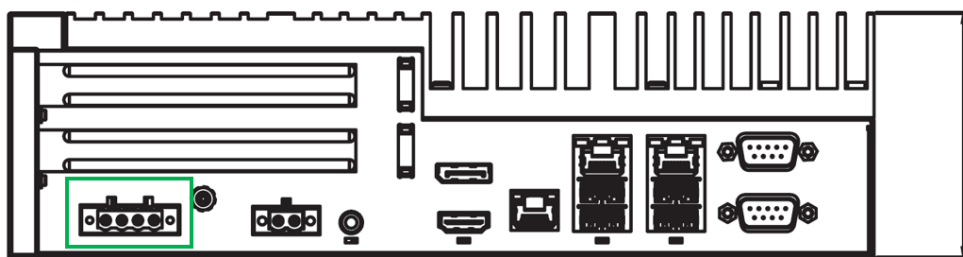

**Figure 2.24 Power Connector**

4. Power on the system. The power LED on the display module turns to green.
5. Calibrate the touchscreen if it is resistive one.

## 2.3 Driver Installation

### 2.3.1 Chipset, Graphics, ME, and LAN Driver Installation

Relevant drivers must be installed for full functionality. Install the chipset, graphics, ME, and LAN drivers individually. The drivers can be downloaded from the TPC-B620 product page of the Advantech website.

### 2.3.2 Watchdog Driver Installation

If the Advantech watchdog driver is not pre-installed on the TPC system, users will need to install the driver.

Follow the steps outlined below to install the Advantech watchdog driver.

1. Verify that the computer meets the hardware and software requirements to run the Advantech watchdog driver.
2. If you do not already have the installer for the Advantech watchdog driver, download it from the Advantech website.
3. From the Control Panel, remove any existing installation of the Advantech watchdog driver from the computer.
4. With administrator-level privileges, run the installer for the Advantech watchdog driver.

Below is an example of the Advantech watchdog driver setup. To stop the setup process at any time, click the “Cancel” button on the pop-up screen. The setup program will stop the procedure automatically.

1. Open the setup program. When the setup program is running, click the **Next** button on the Advantech Watchdog Driver Setup Wizard pop-up screen



2. Wait until the Advantech Watchdog Driver Setup Wizard has completed the installation.

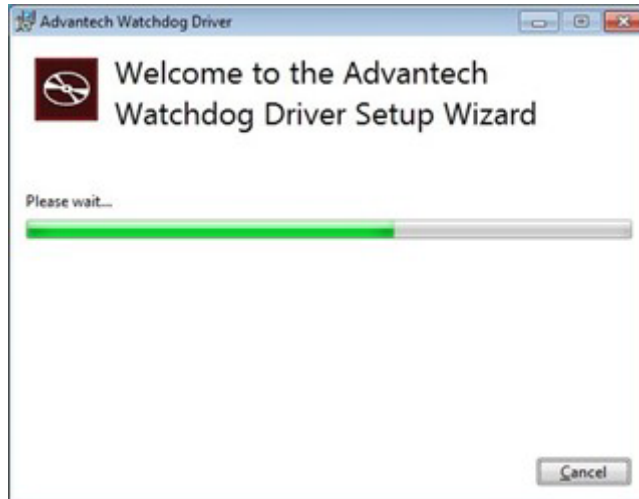

3. Click the **Install** button to continue the installation of the Advantech watchdog driver software.

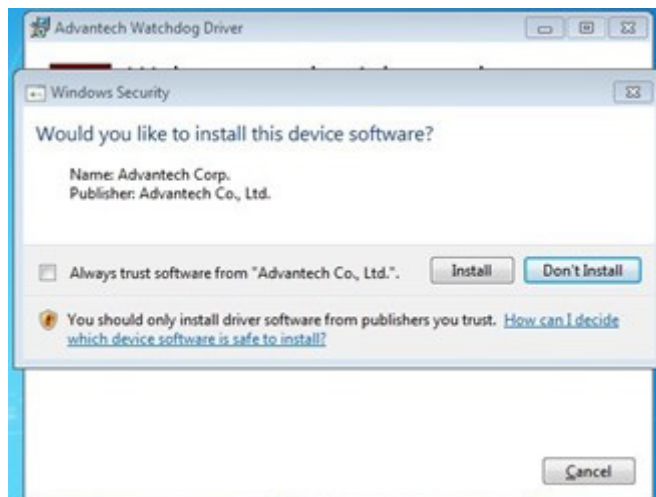

4. Click the **Restart** or **Close** button on the Advantech Watchdog Driver Setup Wizard pop-up screen to complete the setup.



## 2.4 Cabinet Installation and Earth Grounding Setup

Follow these steps to set up the TPC-B620 system, ensuring that the Ground pin of the TPC-B620 system is properly connected to the earth ground. This connection is crucial for optimizing the performance of the TPC-B620 system, including enhanced EMI immunity, ESD immunity, and surge immunity. If the TPC-B620 system is embedded in a cabinet, make sure to connect the TPC-B620 system's ground, the cabinet's ground, and the earth ground together.

### 2.4.1 Installing TPC into Cabinet.

1. Connect the cabinet to earth ground.
2. Embed null TPC-B620 system into the cabinet without any I/O cable and power.

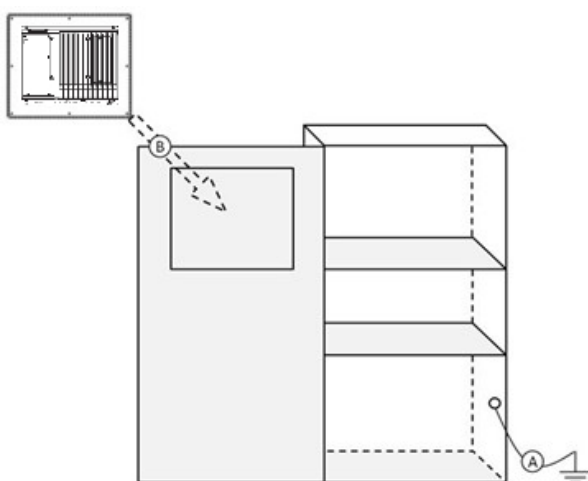

Figure 2.25 Cabinet Installation

## 2.4.2 System Wiring

1. Ground the cabinet to earth.
2. Ensure proper grounding for all cabinets.
3. Connect the power supply ground to the cabinet.
4. Connect the TPC-B620 system's ground pin to the cabinet.
5. If necessary, connect I/O to the controller.
6. Connect the power supply's V+ and V- to the TPC-B620 system.
7. Proceed step by step through steps 1 to 6, then power on the TPC-B620 system.

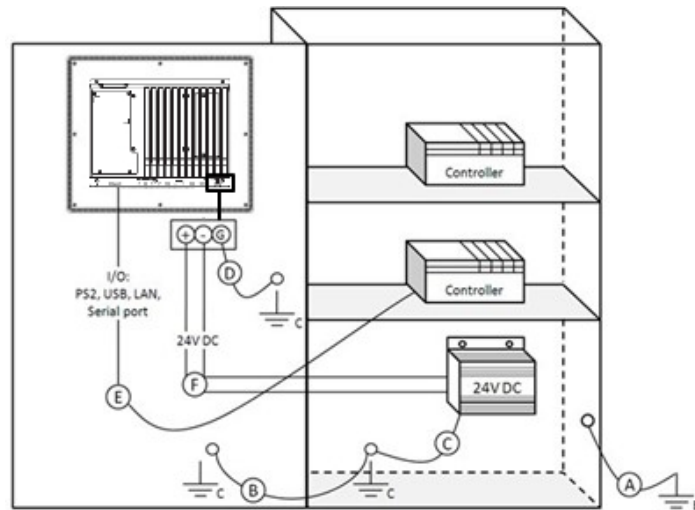

Figure 2.26 System Wiring

**NOTE!** Make sure all wires follow the installation guidelines to avoid performance issues.



## 2.5 Panel Mounting

1. There is an adhesive waterproof gasket on the front bezel of the FPM display module. Make sure the waterproof gasket is in position before installing TPC into the panel opening.
2. Install the TPC into the panel opening. The suggested mounting panel thickness is less than 6 mm (0.236 in).



**Figure 2.27 Panel Mounting (1)**

3. Retrieve the clamps and long screws from the accessory pack. Hook the clamp into the holes around the four sides of the bezel.  
Screws = M4, 25L Min. type or M5, 20L Min. type

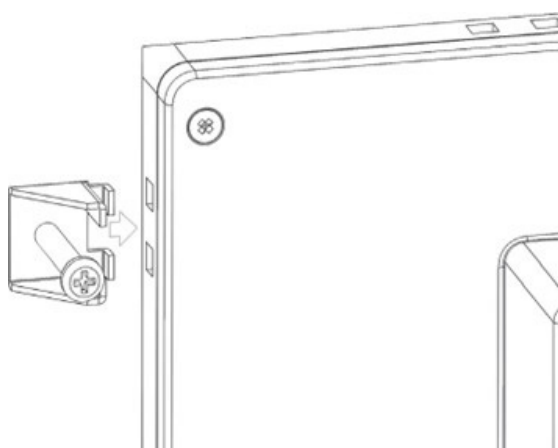

**Figure 2.28 Panel Mounting (2)**

4. Fasten the screws with a torque of 2 kgf-cm. These screws will push the mounting panel, ensuring a secure and stable unit.

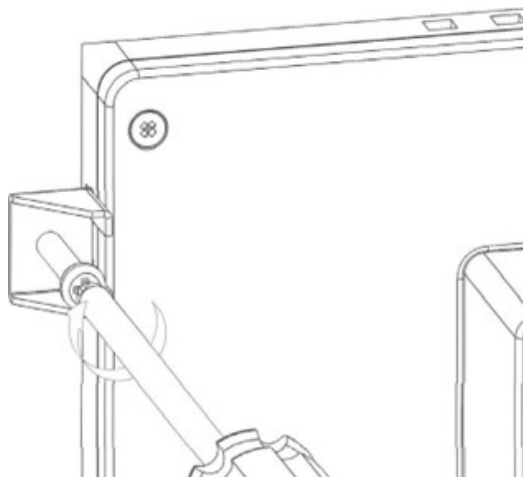

Figure 2.29 Panel Mounting (3)

## 2.6 Expansion Module Installation

### 2.6.1 Expansion Cover Removal

Unscrew the six screws from the side of the TPC-B620 and remove the L-shaped metal cover.

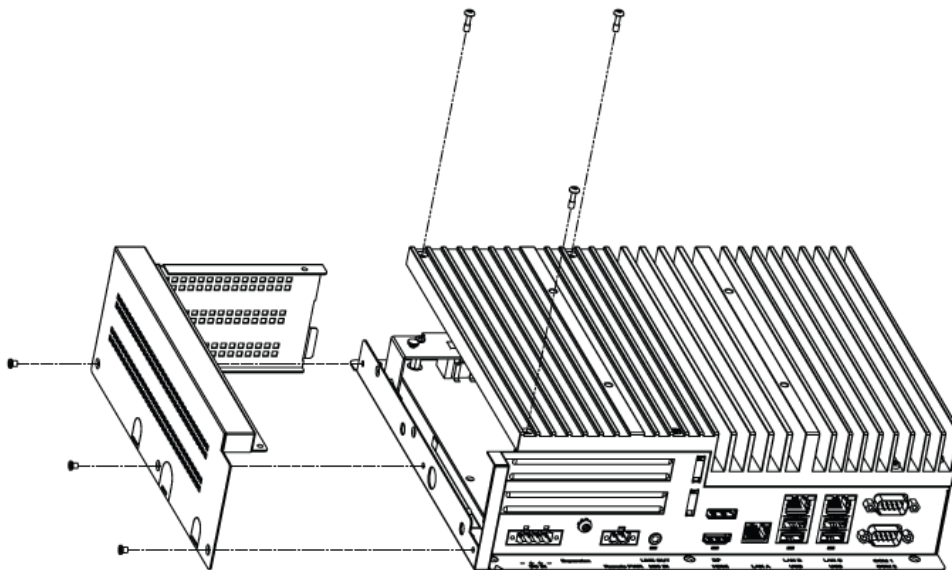
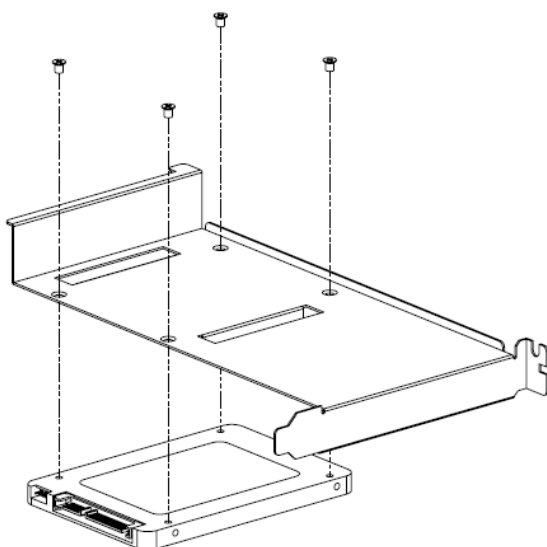

Figure 2.30 Remove L-Shape Side Door

## 2.6.2 Installation of 2.5" SATA SSD

1. Secure the SSD onto the bracket using four M3x4L screws.



**Figure 2.31 Fix 2.5" SSD on Expansion Bracket**

2. Align and slide in your 2.5" SSD expansion module with the top PCIe IO slot and the SATA connector on PCIe daughter board.

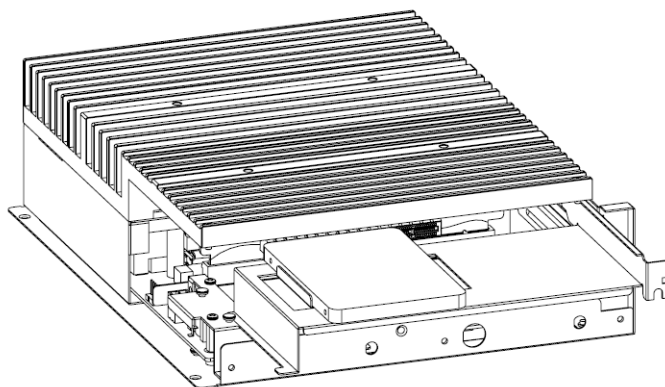

**Figure 2.32 Slide in Expansion Bracket**

3. Lock the bracket with the screw in the accessory of SSD expansion kit.

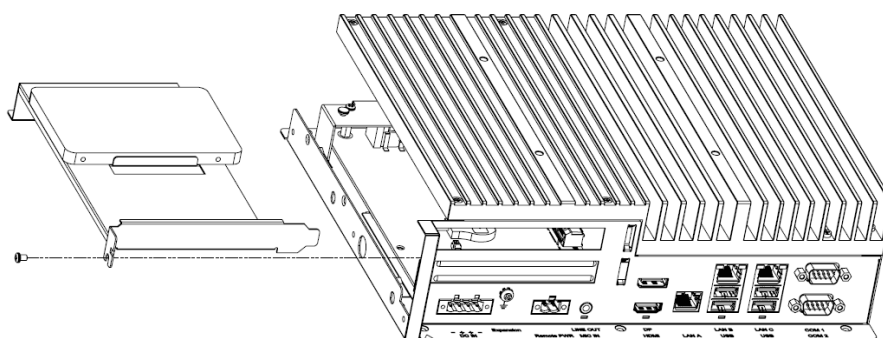

**Figure 2.33 Front View for Slide in Expansion Bracket**

4. Ensure the SATA bracket is fixed.

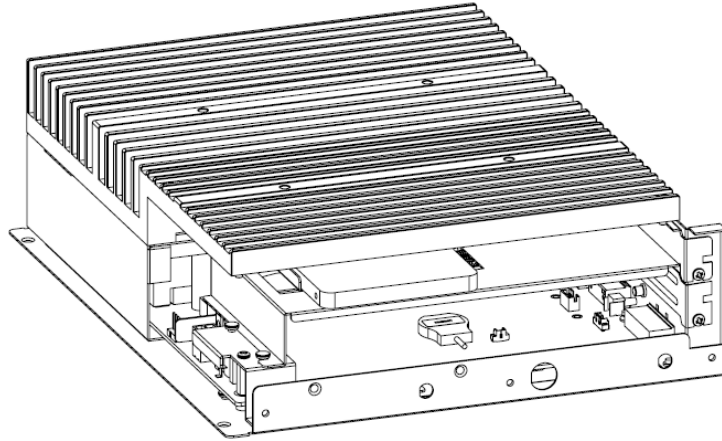

**Figure 2.34 Side View for Expansion Bracket**

5. Screw the six screws from the side of the TPC-B620 for fixing the L-shaped metal cover.

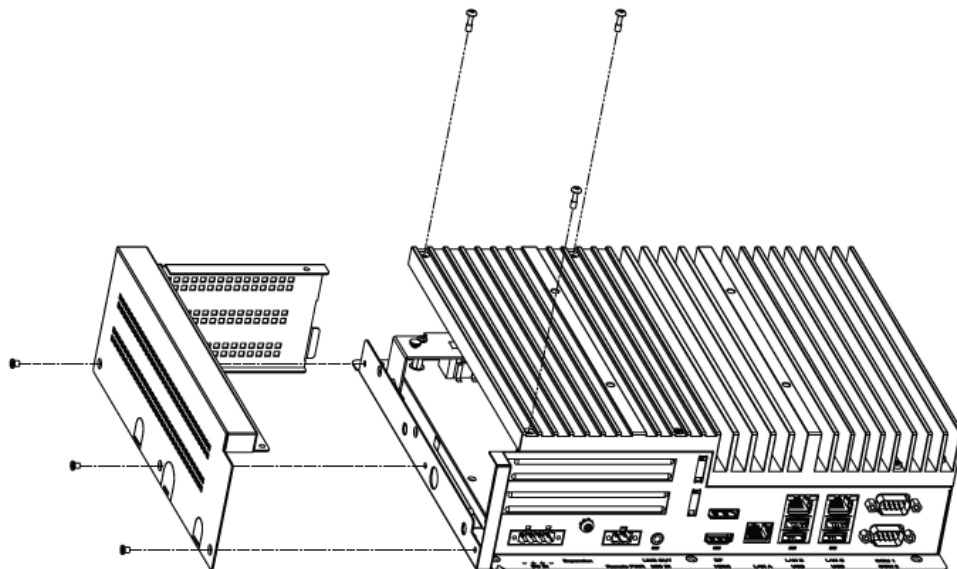

**Figure 2.35 Install L-Shape Side Door**

**NOTE!** A SATA expansion kit (98R1B620000) is required for 2.5" SATA SSD installation.



### 2.6.3 Installation of Remote Button

1. Locate the remote button connector on the rear panel.

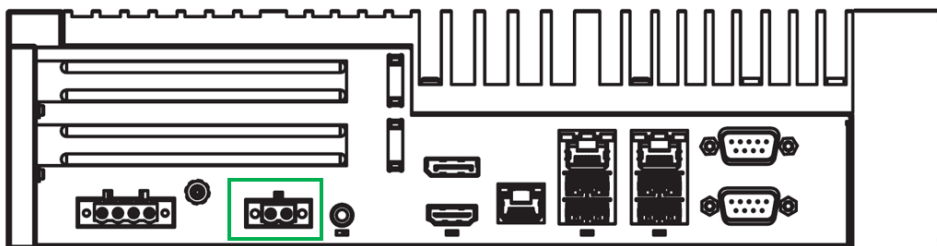

2. Take the remote button kit and insert it into the connector.



3. Use a screwdriver to tighten the two side screws on the remote button kit.

**NOTE!** A remote button kit (98R1B520002) is required for remote button installation.



# Chapter 3

BIOS Setup

## 3.1 BIOS Setup

With the AMI BIOS Setup program, users can modify the BIOS settings and control various system features. This chapter describes the basic navigation of the BIOS Setup Utility.

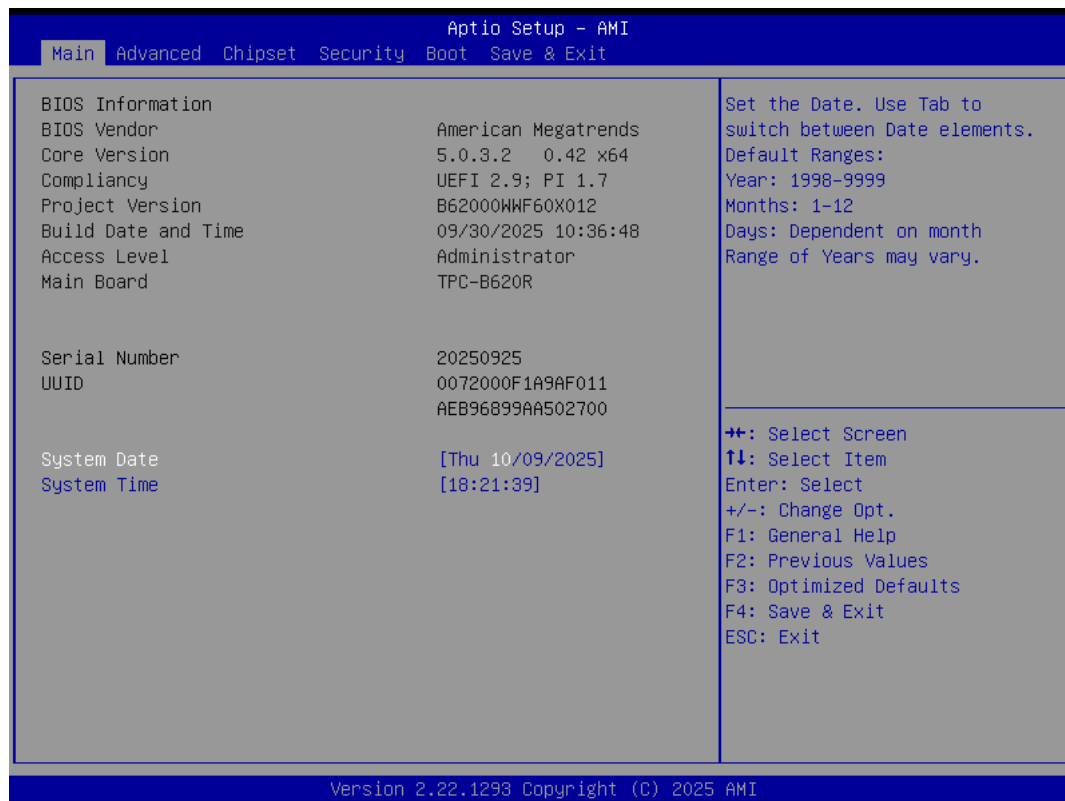

AMI's BIOS ROM has a built-in setup program that allows users to modify the basic system configuration. The setup information is stored in flash ROM to ensure it is retained when the system is powered off.

## 3.2 Entering Setup

Turn on the computer and check for the patch code. If there is a number assigned to the patch code, it means that the BIOS supports your CPU. If there is no number assigned to the patch code, contact an Advantech application engineer to obtain an up-to-date patch code file. This will ensure that the CPU status is valid. After ensuring that you have a number assigned to the patch code, press <DEL> to access the BIOS Setup Utility.

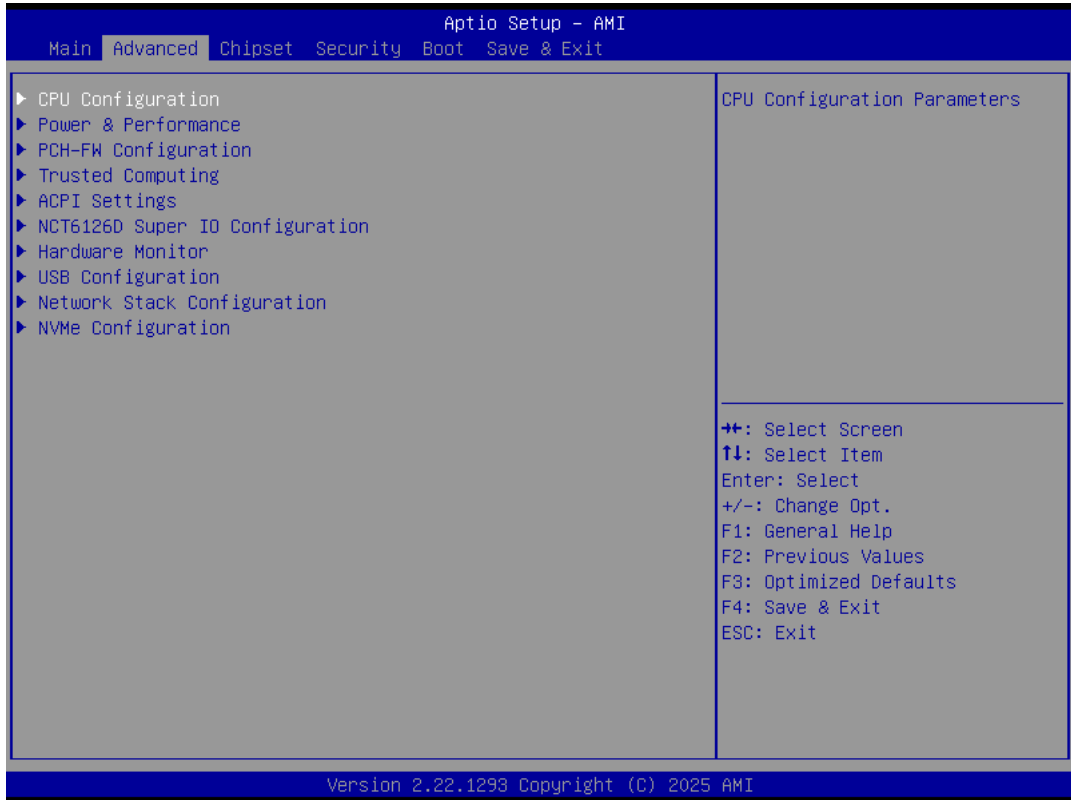

### 3.2.1 Main Setup

Upon entering the BIOS Setup Utility, users will be on the Main setup screen. At any point during the configuration, users can return to the Main setup screen by selecting the Main tab. There are two Main setup options, which are described in this section. The Main setup screen is shown below.



The Main BIOS setup screen has two main frames. The left frame displays all the options that can be configured. Grayed-out options cannot be configured, options in blue can. The right frame displays the key legend.

Above the key legend is an area reserved for a text message. When an option is selected in the left frame, it is highlighted in white. Often a text message will accompany it.

#### ■ System Time/System Date

Use this option to change the system time and date. Highlight System Time or System Date using the <Arrow> keys. Enter new values through the keyboard. Press the <Tab> key or the <Arrow> keys to move between fields. The date must be entered in MM/DD/YY format. The time must be entered in HH:MM:SS format.

### 3.2.2 Advanced BIOS Features Setup

Select the Advanced tab from the TPC-B620 setup screen to enter the Advanced BIOS Setup screen. You can select any of the items in the left frame of the screen, such as ACPI Settings and hit <enter> to go to the sub menu for that item. You can display an Advanced BIOS Setup option by highlighting it using the <Arrow> keys. All Advanced BIOS Setup options are described in this section. The Advanced BIOS Setup screen is shown below. The sub menus are described on the following pages.

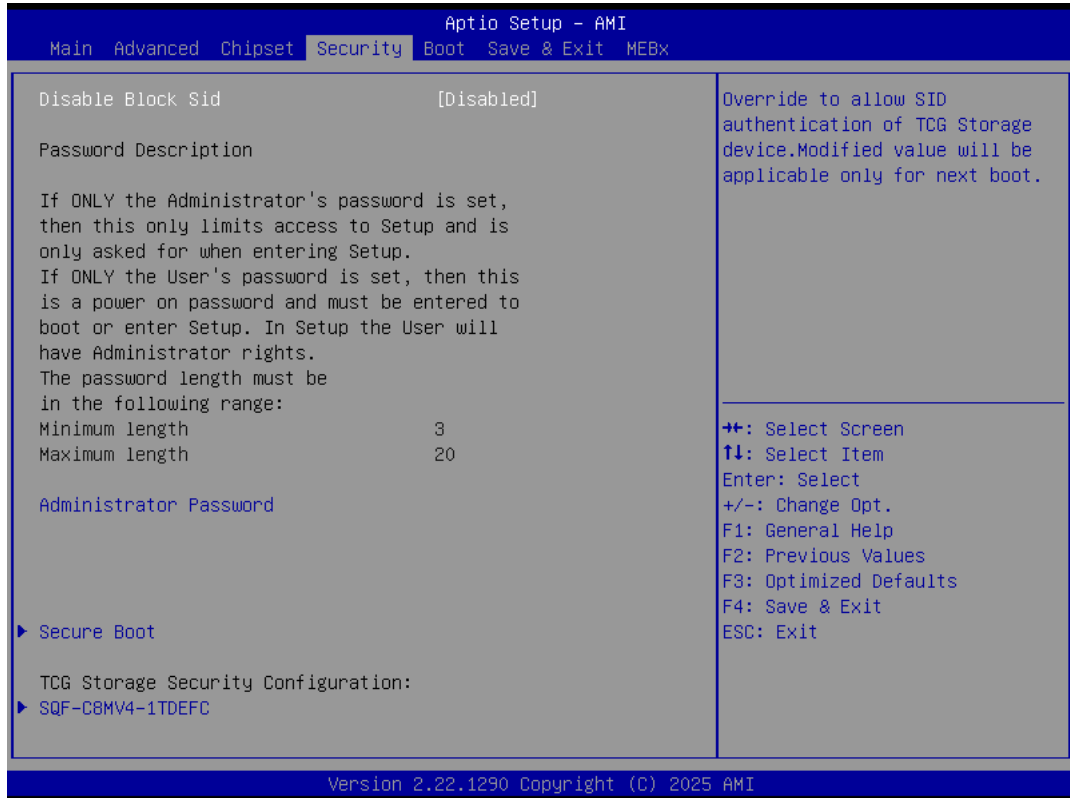

### 3.2.2.1 CPU Configuration

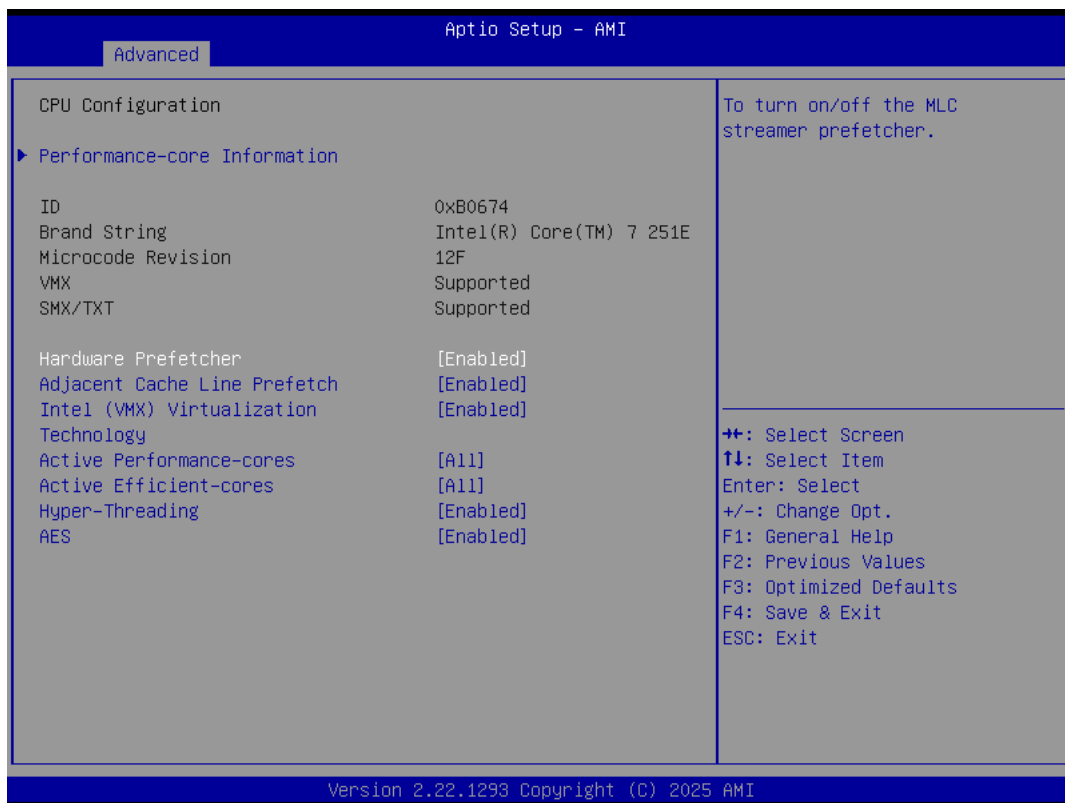

#### ■ Performance-core Information

This submenu displays hardware details about the high-performance cores in Intel® hybrid architecture processors.

#### ■ Hardware Prefetcher

This item allows user to Enables or disables the CPU's ability to prefetch data into the cache automatically.

#### ■ Adjacent Cache Line Prefetch

This item allows user to enable or disable the function for processor fetches the immediately following cache line (the "adjacent" one) into cache.

#### ■ Intel (VMX) Virtualization Technology

This item allows user to enables or disable hardware-assisted virtualization features within the processor.

#### ■ Active Performance-cores

This item allows user to specify how many of the processor's Performance-cores (P-cores) are enabled and available to the system.

#### ■ Active Efficient-cores

This item allows user to specify how many of the processor's Efficient-cores (E-cores) are enabled and available to the system.

#### ■ Hyper-Threading

This item allows user to enable or disable each physical Performance-core (P-core) in the processor to execute two instruction threads simultaneously

- **AES**

This item allows user to enable or disable the processor uses dedicated hardware logic to execute AES encryption and decryption operations

### 3.2.2.2 Power & Performance

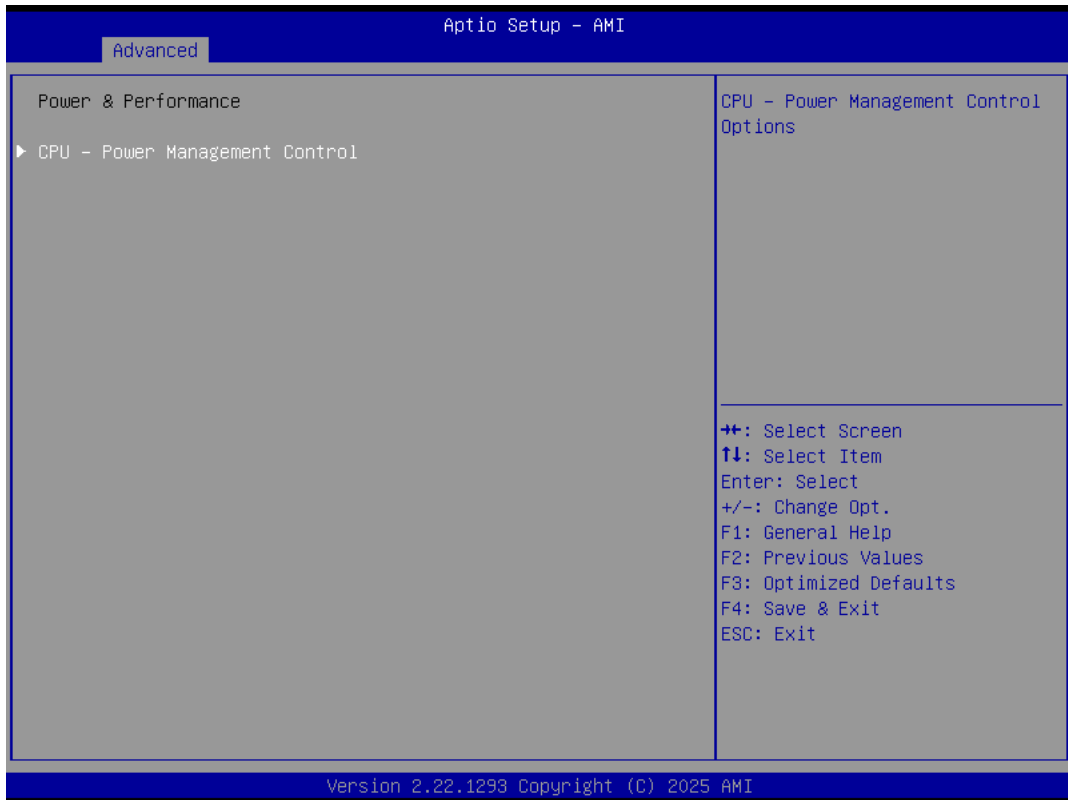

- **CPU – Power Management Control**

This submenu allows users to configure how the processor manages its power consumption, frequency scaling, and thermal behavior.

### 3.2.2.3 PCH-FW Configuration

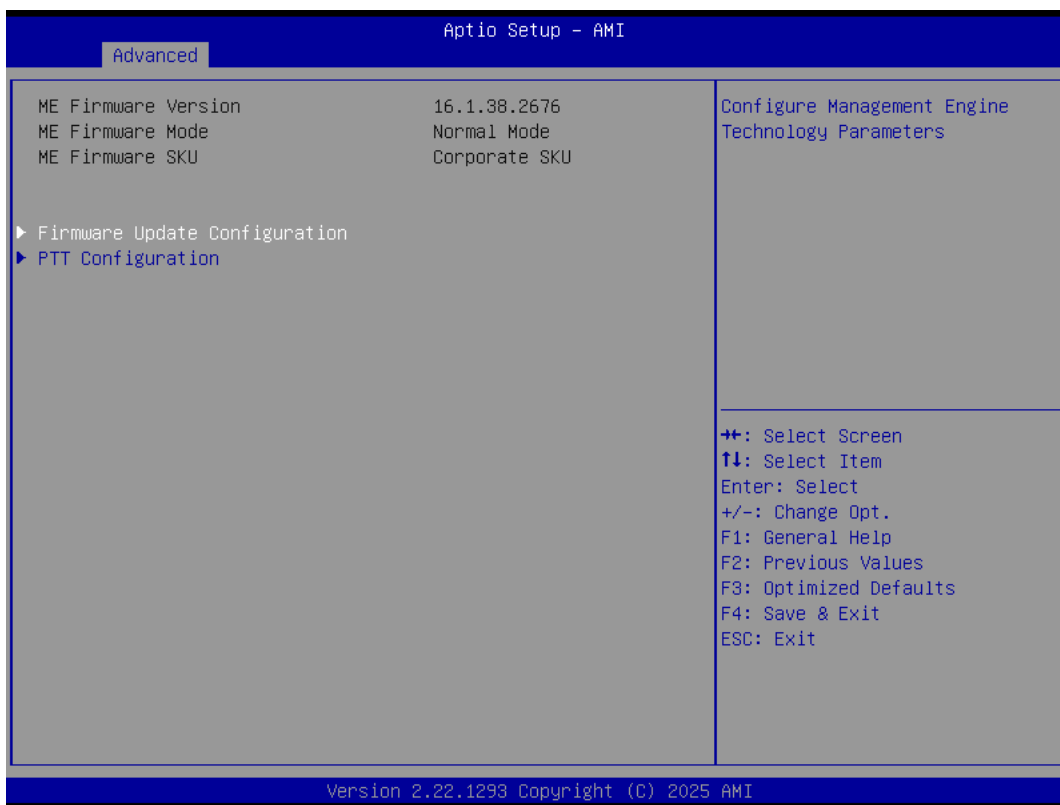

- **Firmware Update Configuration**

This item allows users to configure the management engine technology parameters.

- **PTT Configuration**

This item allows users to configure the PTT configuration function.

### 3.2.2.4 Trusted Computing



#### ■ Security Device Support

This item allows user to enable or disable the system's Trusted Platform Module (TPM) functionality.

#### ■ SHA256 PCR Bank

This item allows user to enable or disable SHA-256 hashing algorithm for its Platform Configuration Registers (PCRs).

#### ■ SHA384 PCR Bank

This item allows user to enable or disable SHA-384 hashing algorithm for its Platform Configuration Registers (PCRs).

#### ■ Pending operation

This item allows user to set and specify the management action that will be performed on the system's TPM (Trusted Platform Module) during the next system reboot.

#### ■ Platform Hierarchy

This item allows user to enable or disable the Platform Hierarchy within the TPM 2.0 (Trusted Platform Module).

#### ■ Storage Hierarchy

This item allows user to enable or disable the Storage Hierarchy within the TPM 2.0 (Trusted Platform Module).

#### ■ Endorsement Hierarchy

This item allows user to enable or disable the Endorsement Hierarchy within the

TPM 2.0 (Trusted Platform Module).

- **Physical Presence Spec Version**

The Physical Presence Spec Version setting specifies which TPM Physical Presence Interface (PPI) specification version the system firmware (BIOS) follows when executing user-authorized TPM operations, such as clearing, enabling, or disabling the TPM device.

- **Device Select**

The Device Select option determines which Trusted Platform Module (TPM) device the system uses to provide TPM 2.0 functionality.

### 3.2.2.5 ACPI Settings

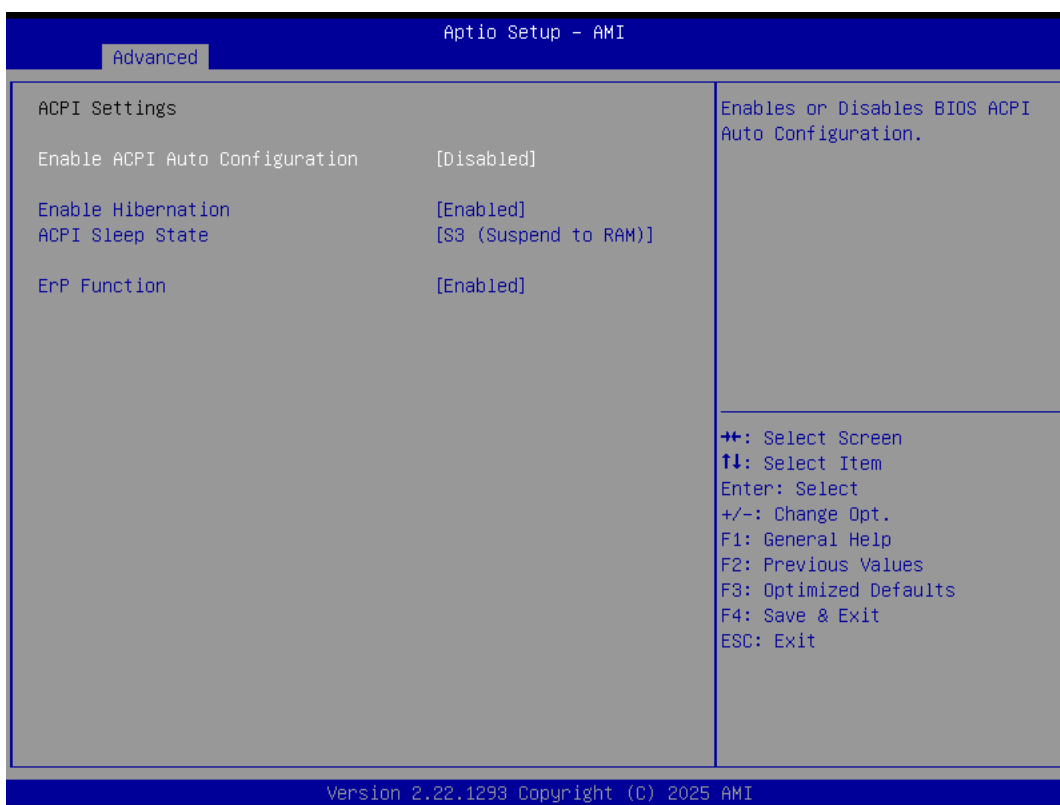

- **Enable ACPI Auto Configuration**

This item allows users to enable or disable “ACPI Auto Configuration”.

- **Enable Hibernation**

This item allows users to enable or disable System ability to hibernate (OS/S4 sleep state). This option may be not effective with some OS.

- **ACPI Sleep State**

This item allows users to select the highest ACPI sleep state. The system will enter when the SUSPEND button is pressed.

- **ErP Function**

This item allows users to enable or disable “ErP Function”.

### 3.2.2.6 NCT6126D Super I/O Configuration



- **Serial Port 1 Configuration**  
Set Parameters of Serial Port 1 (COM1).
- **Serial Port 2 Configuration**  
Set Parameters of Serial Port 2 (COM2).

## 3.2.2.7 Trusted Computing



- **TPM Device Selection**

This item allows users to select TPM device: fTPM or dTPM.

fTPM: Enables fTPM.

dTPM: Disables fTPM and enable dTPM.

Warning! fTPM/dTPM will be disabled and all data saved on it will be lost.

Avertissement! fTPM/dTPM sera désactivé et toutes les données enregistrées dessus seront perdues.

- **Security Device Support**

This item allows users to enable/disable BIOS support for security devices. The OS will not show the security devices. The TCG EFI protocol and INT1A interface will not be available.

- **SHA-1 PCR Bank**

This item allows users to enable/disable SHA-1 PCR bank.

- **SHA256 PCR Bank**

This item allows users to enable/disable SHA256 PCR bank.

- **SHA384 PCR Bank**

This item allows users to enable/disable SHA384 PCR bank.

- **Pending Operation**

This item allows users to schedule an operation for the security device.

Note: The computer must be restarted to change the security device state.

- **Platform Hierarchy**

This item allows users to enable/disable platform hierarchy.

- **Storage Hierarchy**

This item allows users to enable/disable storage hierarchy.

- **Endorsement Hierarchy**

This item allows users to enable/disable endorsement hierarchy.

- **Physical Presence Spec Version**

This item allows users to enable support for PPI spec version 1.2 or 1.3.

Note: Some HCK tests may not support version 1.3.

- **Device Select**

TPM 1.2: select this to restrict support to TPM 1.2 devices.

TPM 2.0: select this to restrict support to TPM 2.0 devices

Auto: select this to support both; TPM 2.0 devices by default; if not found, TPM 1.2 devices will be enumerated

### 3.2.2.8 Hardware Monitor Configuration

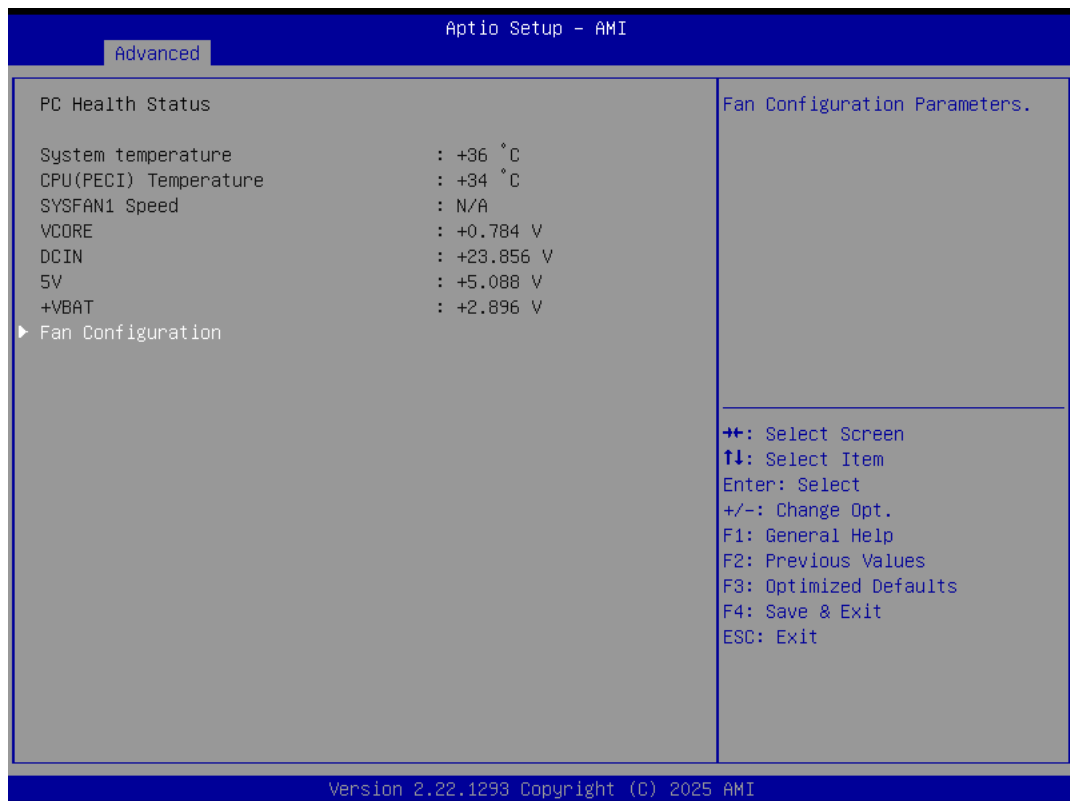

- **Fan Configuration**

This item allows users to monitor and adjust the cooling behavior of system fans connected to the motherboard or embedded controller.

### 3.2.2.9 USB Configuration

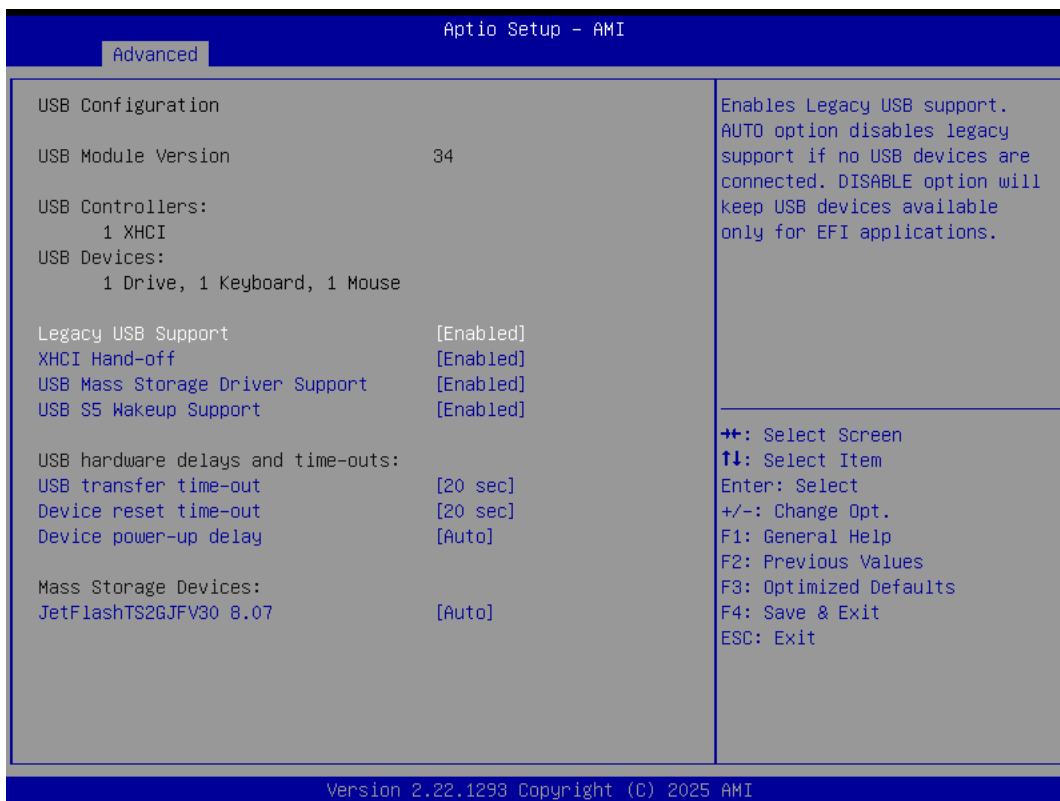

#### ■ Legacy USB Support

Enables Legacy USB support. The AUTO option disables legacy support if no USB devices are connected. The DISABLE option will keep USB devices available only for EFI applications.

#### ■ XHCI Hand-off

This is a workaround of 0 Secs without XHCI hand-off support. The XHCI ownership change should be claimed by XHCI driver.

#### ■ USB Mass Storage Driver Support

Enable/Disable USB Mass Storage Driver Support.

#### ■ USB S5 Wakeup Support

This item allows users to enable/disable USB S5 wakeup support.

#### ■ USB Transfer Time-Out

This item allows users to set the time-out value for control, bulk, and Interrupt USB mass storage device transfers.

#### ■ Device Reset Time-Out

This item allows users to set the device reset command time-out.

#### ■ Device Power-Up Delay

This item allows users to Set the maximum time the device will take before reporting itself to the Host Controller. The Auto option uses the default value, which is 100 ms for a Root port. For a Hub port, the delay time is obtained from the Hub descriptor.

### 3.2.2.10 Network Stack Configuration

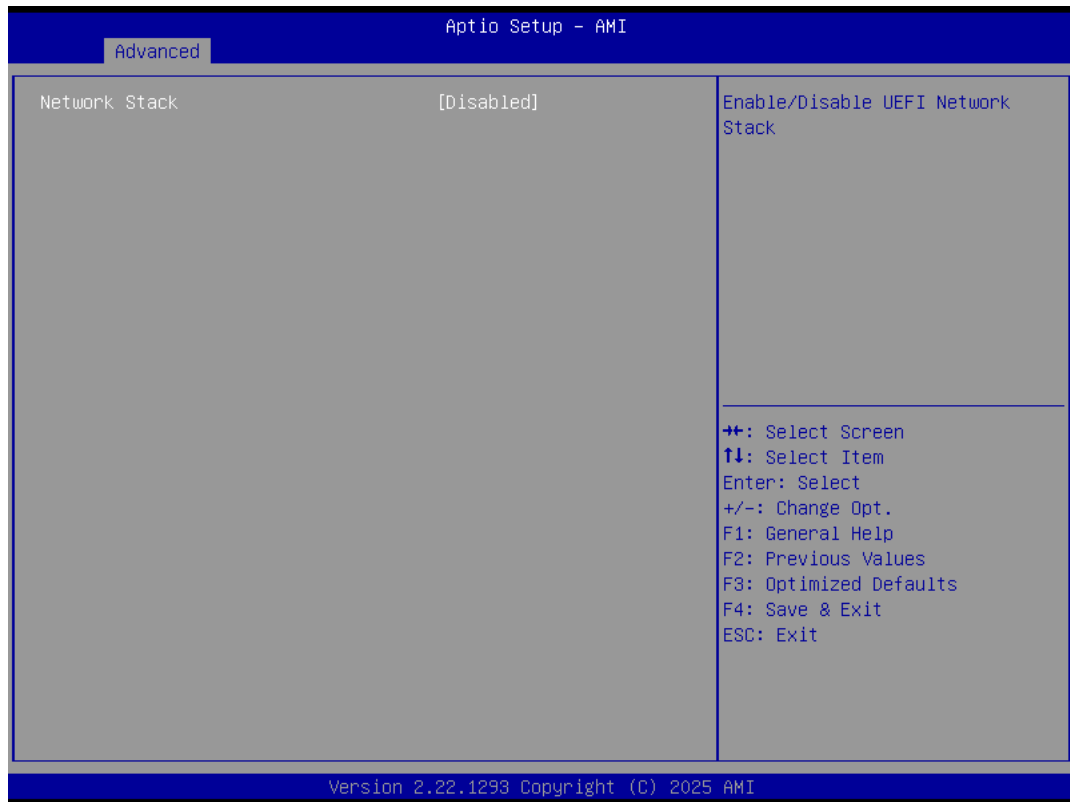

- **Network Stack**

This item allows users to enable or disable the UEFI network stack.

### 3.2.2.11 NVMe Configuration

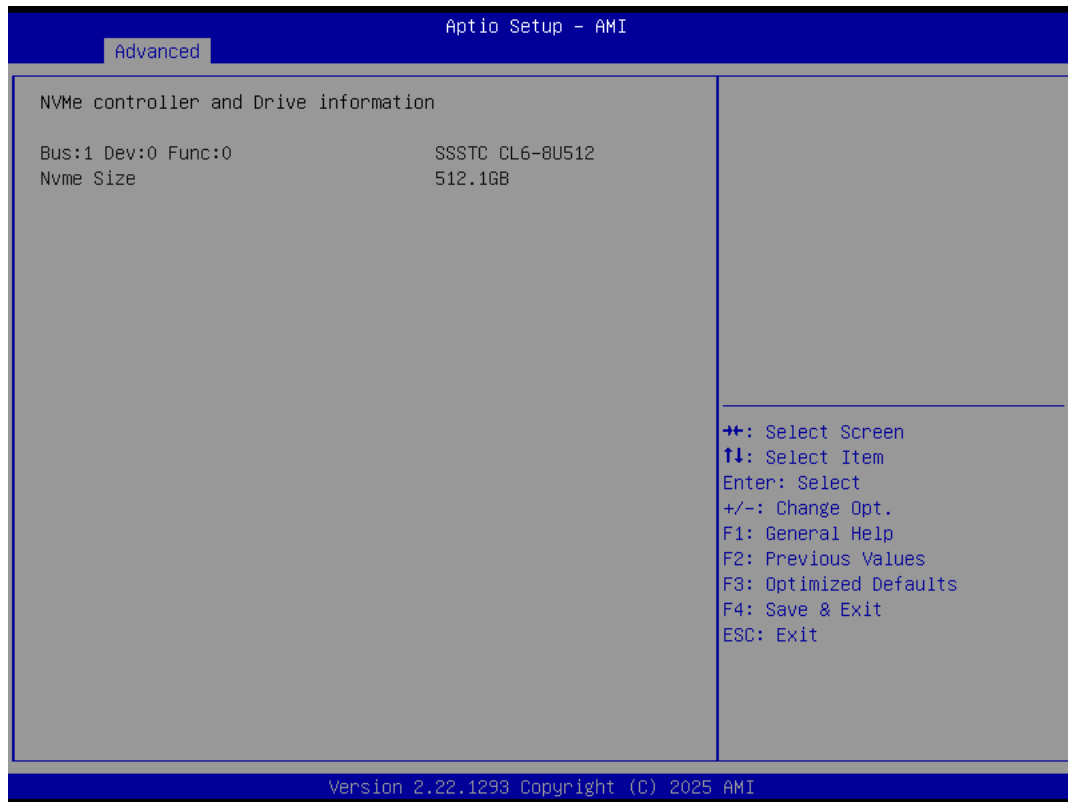

## 3.2.3 Chipset Configuration

### 3.2.3.1 System Agent (SA) Configuration

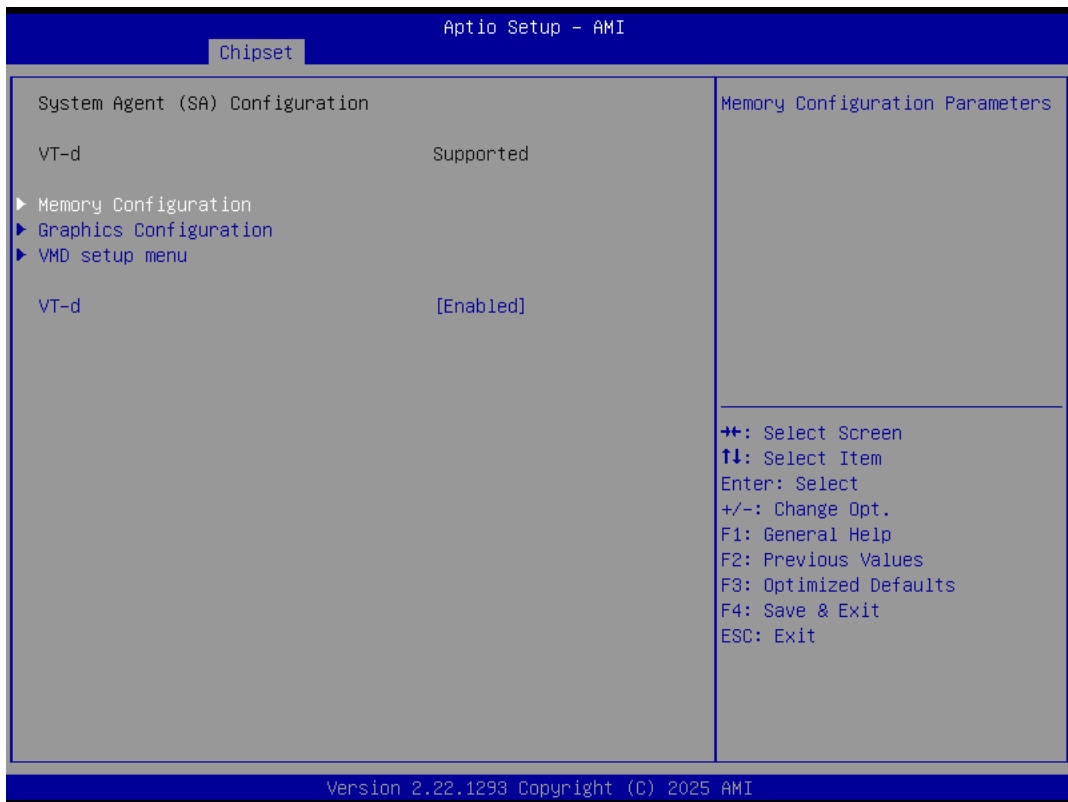

- **Memory Configuration**

This submenu allows users to view the memory parameters.

- **Graphic Configuration**

This submenu allows users to set how the system initializes, allocates memory, and prioritizes between the integrated GPU (iGPU) and any discrete graphics card (dGPU) installed in the system.

- **VMD setup menu**

This submenu allows users to Enable or disable the Intel Volume Management Device.

- **VT-d**

This item allows users to enable or disable VT-d capability

### 3.2.3.2 PCH-IO Configuration



- **PCI Express Configuration**  
This submenu allows users to set the PCI Express settings.
- **SATA Configuration**  
This submenu allows users to set the SATA device settings.
- **HD Audio Configuration**  
This submenu allows users to set the audio configuration settings.
- **Onboard LANA Controller**  
This item allows users to enable or disable the onboard LAN A controller.
- **Onboard LANB Controller**  
This item allows users to enable or disable the onboard LAN B controller.
- **Onboard LANC Controller**  
This item allows users to enable or disable the onboard LAN C controller.
- **PCIe Wake**  
This item allows users to enable or disable the wake option from PCIe devices.
- **PCIe Device Initial Delay**  
This item allows users to set specific time for the system waits before starting PCIe device initialization (enumeration/link training) after certain reset or power-on events.

## 3.2.4 Security

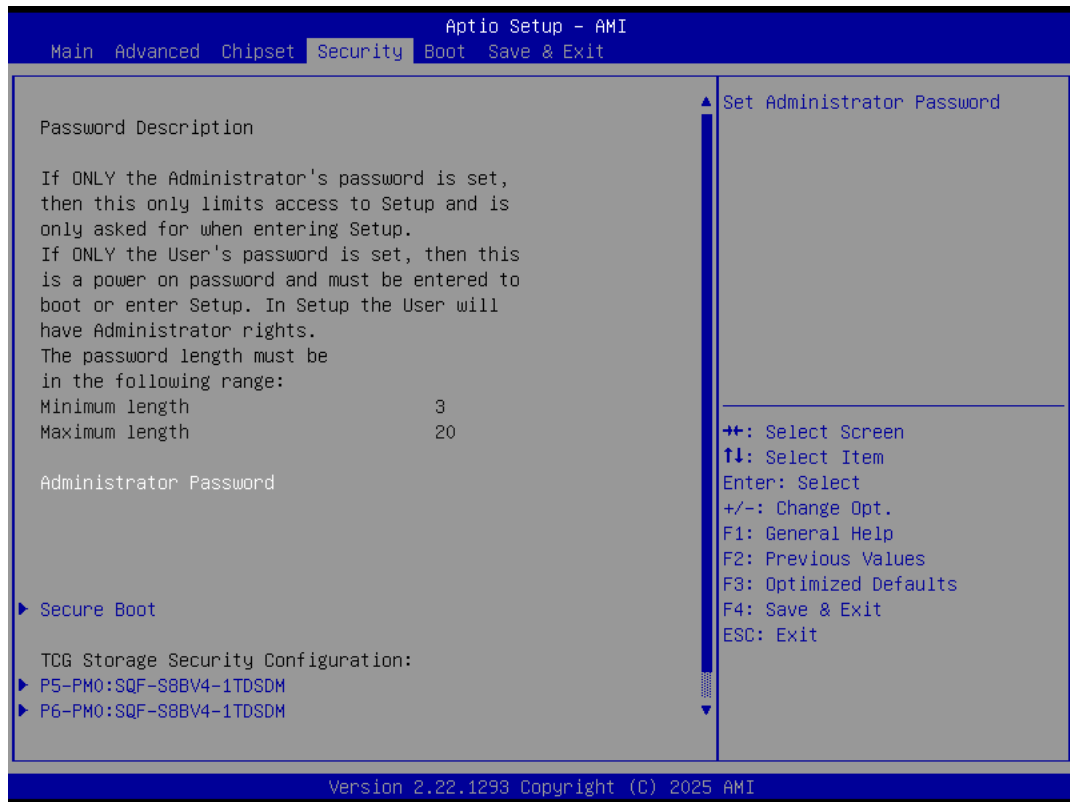

- **Administrator Password**
  - Set Administrator Password
- **Secure Boot**
  - This item allows users to access a submenu to configure secure boot settings.

### 3.2.5 Boot



- **Setup Prompt Timeout**  
This item allows users to set the number of seconds to wait for setup activation key. 65535 (0xFFFF) means indefinite waiting.
- **Bootup NumLock State**  
This item allows users to select the keyboard NumLock state.
- **Quiet Boot**  
This item allows users to enable/disable quiet boot option.

## 3.2.6 Save & Exit



- **Save Changes and Exit**  
This item allows you to exit system setup after saving the changes.
- **Discard Changes and Exit**  
This item allows you to exit system setup without saving any changes.
- **Save Changes and Reset**  
This item allows you to reset the system after saving the changes.
- **Discard Changes and Reset**  
This item allows you to reset system setup without saving any changes.
- **Save Changes**  
This item allows you to save changes done so far to any of the options.
- **Discard Changes**  
This item allows you to discard changes done so far to any of the options.
- **Restore Defaults**  
This item allows you to restore/load default values for all the options.
- **Save as User Defaults**  
This item allows you to save the changes done so far as user defaults.
- **Restore User Defaults**  
This item allows you to restore the user defaults to all the options.

# Appendix **A**

## Connectors

# A.1 Jumper and Connector Location

## A.1.1 Board Layout

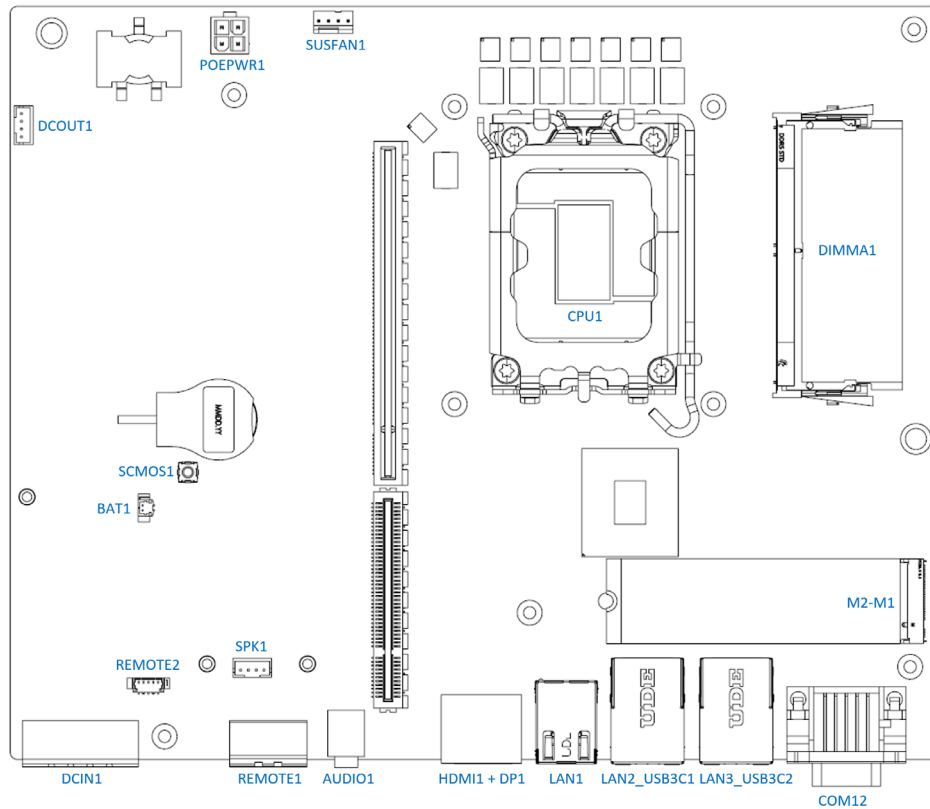

Figure A.1 Board Placement - Top View

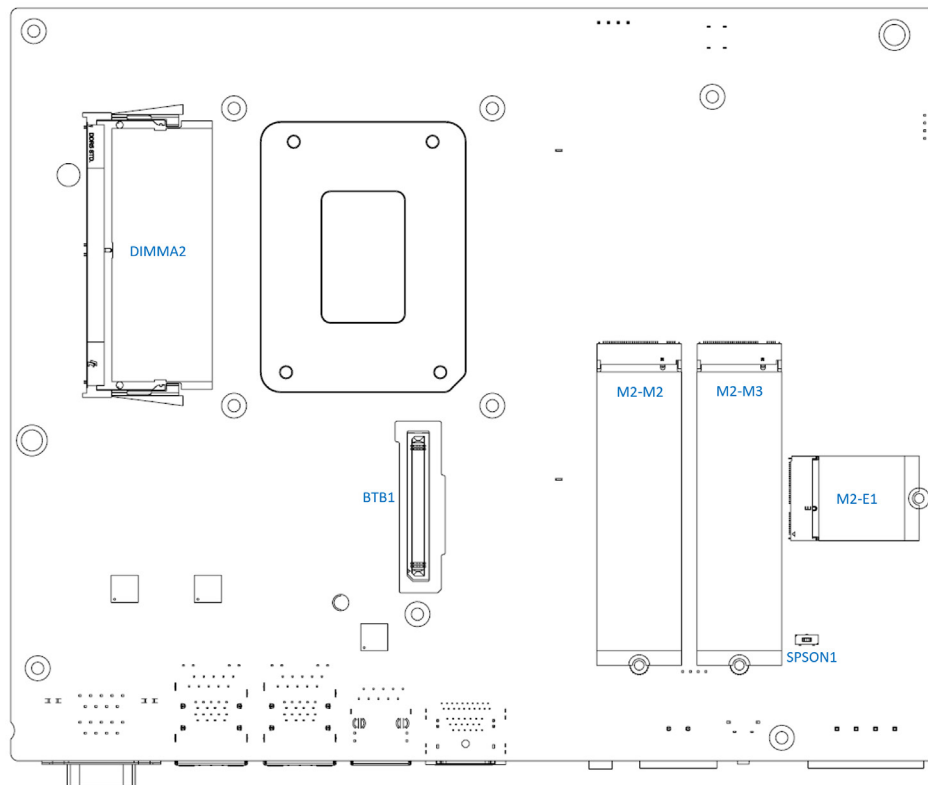

Figure A.2 Board Layout - Bottom View

**Table A.1: Connector and Jumpers**

Place	Function
DCIN1	Power input connector
REMOTE1	Remote button connector
REMOTE2	Remote button connector
AUDIO1	Audio connector
HDMI1+DP1	HDMI+DP connector
LAN1	LAN RJ45 connectors
LAN2_USB3C1	LAN RJ45+USB3 connectors
LAN3_USB3C2	LAN RJ45+USB3 connectors
COM12	COM1,2 RS-232/422/485 connector
M2-M1	M.2 M-Key slot
M2-M2	M.2 M-Key slot
M2-M3	M.2 M-Key slot
M2-E1	M.2 E-key slot
CPU1	Intel LGA1700 Socket
DIMMA1	Memory slot
DIMMB1	Memory slot
COM12	COM1,2 RS-232/422/485 connector
SPK1	Speaker connector
BAT1	RTC battery connector
SCMOS1	Clear CMOS jumper
POEPWR1	POE Power connector
SYSFAN1	Fan connector
SPSON1	AT/ATX setting

## A.2 Jumper Settings and Descriptions

### A.2.1 CMOS Clear Function (SCMOS1)

**Table A.2: CMOS Clear Function**

Description	This switch is used to CMOS clear
-------------	-----------------------------------

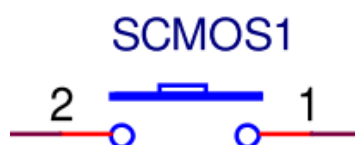

## A.2.2 AT/ATX Select (PSON1)

**Table A.3: AT/ATX Select**

Description	This jumper is used to select power on mode
Default	(1-2)
(1-2)	AT (Default)
(2-3)	ATX

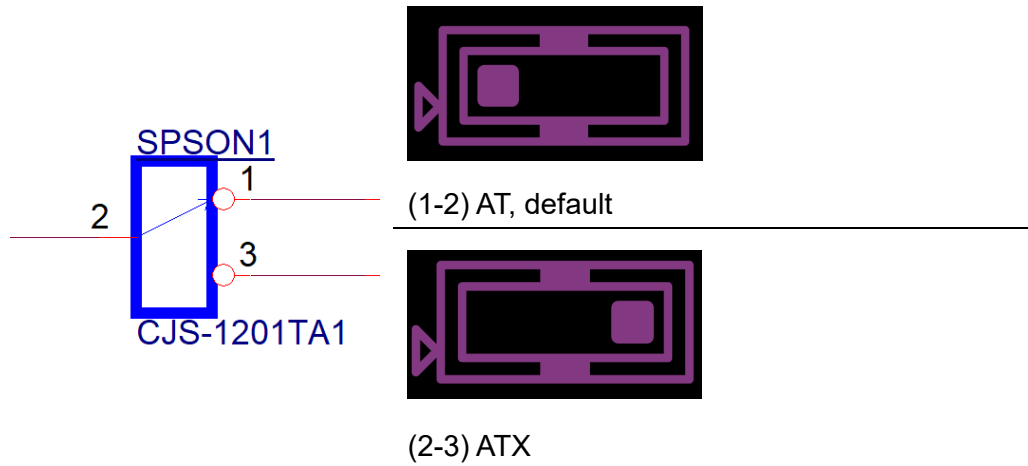

## A.3 Connector Pin Definition

### A.3.1 Remote Button Connector (REMOTE1)

**Table A.4: Remote Button Connector (REMOTE1)**

Pin	Signal
1	ATX_PWRBTN#
5	GND

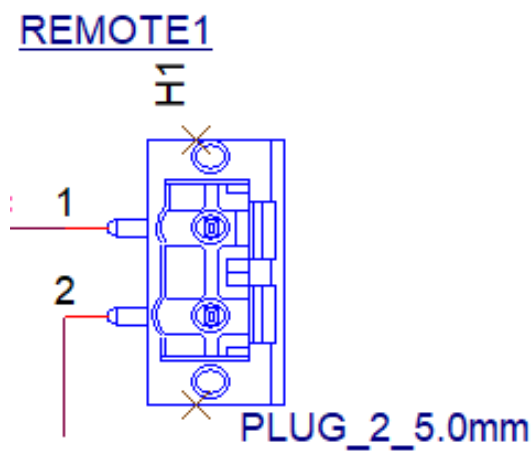

### A.3.2 Remote Button Connector (REMOTE2)

**Table A.5: Remote Button Connector (REMOTE2)**

Pin	Signal
1	ATX_PWRBTN#
2	SYS_RESET#
3	GPI
4	+V3.3
5	GND

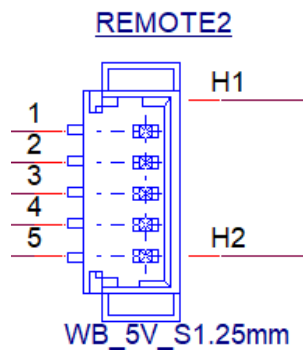

### A.3.3 POE Power Connector (POEPWR1)

**Table A.6: POE Power Connector (POEPWR1)**

Pin	Signal
1	GND
2	GND
3	12V
4	12V

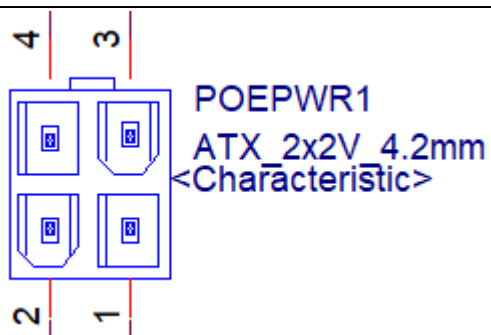

### A.3.4 RTC Battery Connector (BAT1)

**Table A.7: RTC Battery Connector (BAT1)**

Pin	Signal
1	+VBAT
2	GND

BAT1

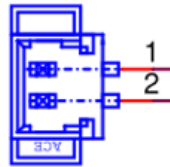

WB\_2V\_S1.25mm

### A.3.5 Speaker Connector (SPK1)

**Table A.8: Speaker Connector (SPK1)**

Pin	Signal
1	L+
2	L-
3	R-
4	R+

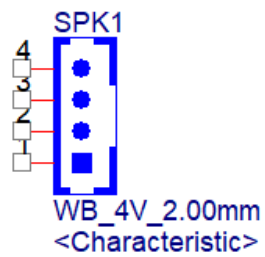

WB\_4V\_2.00mm  
<Characteristic>

### A.3.6 Fan Connector (SYSFAN1)

**Table A.9: System Fan Connector (SYSFAN1)**

Pin	Signal
1	GND
2	12V
3	SENSE
4	PWM

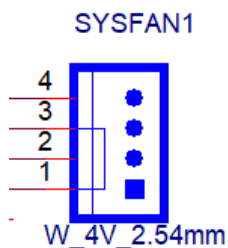

### A.3.7 COM1/2 RS-232/422/485 Connector (COM1&2)

**Table A.10: COM1&2 RS-232/422/485 Connector (COM1&2)**

Pin	RS232	RS422	RS485
1	DCD	TX-	Data-
2	RX	TX+	Data+
3	TX	RX+	
4	DTR	RX-	
5	GND	GND	GND
6	DSR		
7	RTS		
8	CTS		
9	RI		

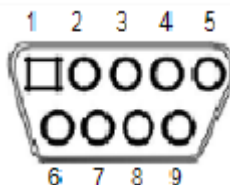

### A.3.8 Power Input Connector (DCIN1)

**Table A.11: Power Input Connector (DCIN1)**

Pin	Signal
1	Power In V- (GND)
2	Power In V+
3	Power In V+
4	Power In V- (GND)

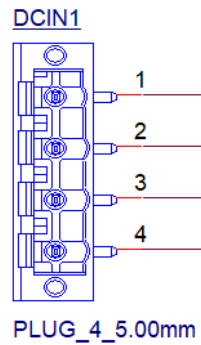

### A.3.9 iDoor Power Connector (DCOUT1)

**Table A.12: iDoor Power Connector (DCOUT1)**

Pin	Signal
1	+VDCIN
2	+VDCIN
3	GND
4	GND

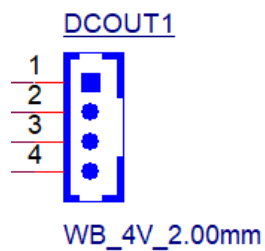

### A.3.10 M.2 M-Key Connector (M2-M1)

**Table A.13: M.2 M-Key Connector (M2-M1)**

Pin	Signal	Pin	Signal
74	3.3V	75	GND
72	3.3V	73	GND
70	3.3V	71	GND
68	SUSCLK	69	PEDET(NC-PCIe/GND-SATA)
58	NC	67	NC
56	NC	57	GND
54	PEWAKE0#	55	REFCLKp
52	CLKREQ0#	53	REFCLKn
50	PERST0#	51	GND
48	NC	49	PETp0 / SATA-A+
46	NC	47	PETn0 / SATA-A-
44	NC	45	GND
42	NC	43	PERp0 / SATA-B-
40	NC	41	PERn0 / SATA-B+
38	DEVSLP	39	GND
36	NC	37	PETp1
34	NC	35	PETn1
32	NC	33	GND
30	NC	31	PERp1
28	NC	29	PERn1
26	NC	27	GND
24	NC	25	PETp2
22	NC	23	PETn2
20	NC	21	GND
18	3.3V	19	PERp2
16	3.3V	17	PERn2
14	3.3V	15	GND
12	3.3V	13	PETp3
10	NC	11	PETn3
8	NC	9	GND
6	NC	7	PERp3
4	3.3V	5	PERn3
2	3.3V	3	GND
		1	GND

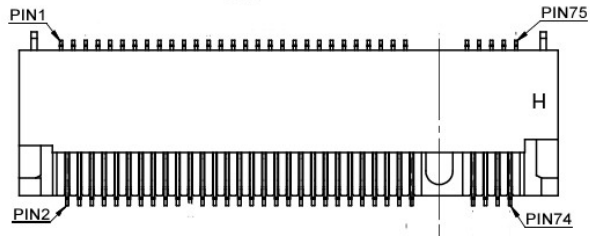

### A.3.11 M.2 M-Key Connector (M2-M2)

**Table A.14: M.2 M-Key Connector (M2-M2)**

Pin	Signal	Pin	Signal
74	3.3V	75	GND
72	3.3V	73	GND
70	3.3V	71	GND
68	SUSCLK	69	PEDET(NC-PCIe/GND-SATA)
58	NC	67	NC
56	NC	57	GND
54	PEWAKE0#	55	REFCLKp
52	CLKREQ0#	53	REFCLKn
50	PERST0#	51	GND
48	NC	49	PETp0 / SATA-A+
46	NC	47	PETn0 / SATA-A-
44	NC	45	GND
42	NC	43	PERp0 / SATA-B-
40	NC	41	PERn0 / SATA-B+
38	DEVSLP	39	GND
36	NC	37	PETp1
34	NC	35	PETn1
32	NC	33	GND
30	NC	31	PERp1
28	NC	29	PERn1
26	NC	27	GND
24	NC	25	PETp2
22	NC	23	PETn2
20	NC	21	GND
18	3.3V	19	PERp2
16	3.3V	17	PERn2
14	3.3V	15	GND
12	3.3V	13	PETp3
10	NC	11	PETn3
8	NC	9	GND

6	NC	7	PERp3
4	3.3V	5	PERn3
2	3.3V	3	GND
		1	GND

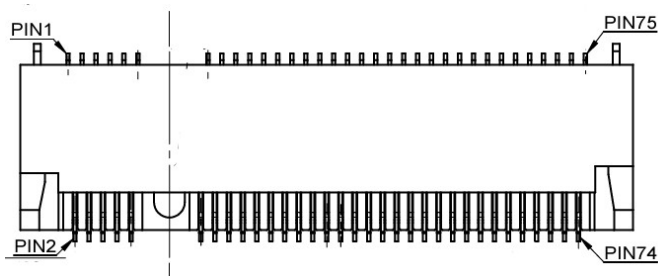

### A.3.12 M.2 B-Key Connector (M2-M3)

**Table A.15: M.2 B-Key Connector (M2-M3)**

Pin	Signal	Pin	Signal
74	3.3V	75	GND
72	3.3V	73	GND
70	3.3V	71	GND
68	NC	69	NC
58	NC	67	NC
56	NC	57	GND
54	NC	55	NC
52	NC	53	NC
50	NC	51	GND
48	NC	49	SATA-A+
46	NC	47	SATA-A-
44	NC	45	GND
42	NC	43	SATA-B-
40	NC	41	SATA-B+
38	NC	39	GND
36	NC	37	NC
34	NC	35	NC
32	NC	33	GND
30	NC	31	NC
28	NC	29	NC
26	NC	27	GND
24	NC	25	NC
22	NC	23	NC
20	NC	21	GND
18	3.3V	19	NC

16	3.3V	17	NC
14	3.3V	15	GND
12	3.3V	13	NC
10	NC	11	NC
8	NC	9	GND
6	NC	7	NC
4	3.3V	5	NC
2	3.3V	3	GND
		1	GND

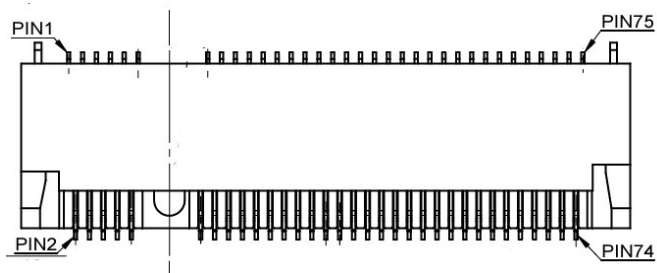

### A.3.13 M.2 B-Key Connector (M2-E1)

**Table A.16: M.2 B-Key Connector (M2-E1)**

Pin	Signal	Pin	Signal
74	3.3V	75	GND
72	3.3V	73	NC
70	NC	71	NC
68	NC	69	GND
66	NC	67	NC
64	NC	65	NC
62	NC	63	GND
60	NC	61	NC
58	NC	59	NC
56	NC	57	GND
54	NC	55	PEWAKE0#
52	PERST0#	53	CLKREQ0#
50	NC	51	GND
48	NC	49	REFCLKn
46	NC	47	REFCLKp
44	NC	45	GND
42	NC	43	PERn0
40	NC	41	PERp0
38	NC	39	GND
36	NC	37	PETn0
34	NC	35	PETp0

32	NC	33	GND
22	NC	23	NC
20	NC	21	NC
18	GND	19	NC
16	NC	17	NC
14	NC	15	NC
12	NC	13	NC
10	NC	11	NC
8	NC	9	NC
6	NC	7	GND
4	3.3V	5	USB_D-
2	3.3V	3	USB_D+
		1	GND

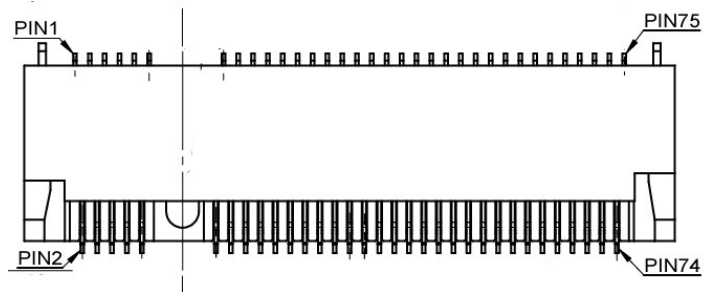

# Appendix **B**

## Driver Installation

## B.1 Intel Chipset Device Software Installation

Follow the steps below to install the Intel Chipset Device Software:

1. Launch <Driver Root Path>\Chipset-10.1.19913.8607-Public-Client
2. Install SetupChipset.exe

DriverFiles	10/3/2025 11:17 PM
Results	10/3/2025 11:17 PM
Symbols	10/3/2025 11:17 PM
CHANGELOG.md	7/9/2024 5:34 PM
extrelnotes.md	7/9/2024 6:10 PM
mup	7/9/2024 5:56 PM
SetupChipset	7/9/2024 5:42 PM
WixLicenseNote	7/9/2024 10:58 AM

3. Click **Next**.

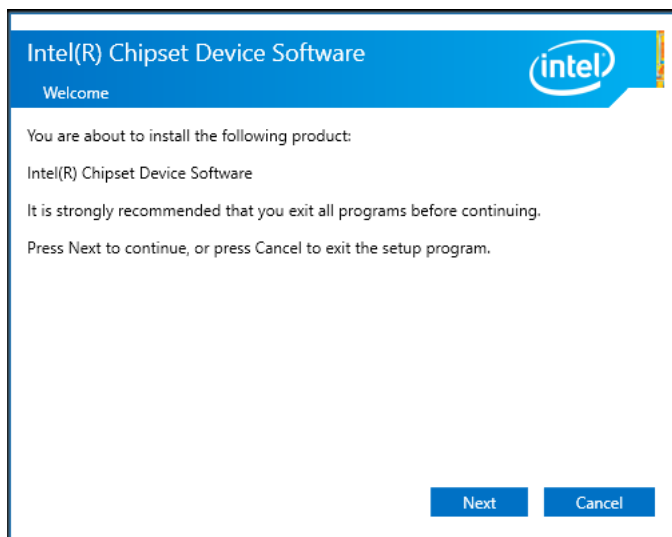

- Click **Accept**.

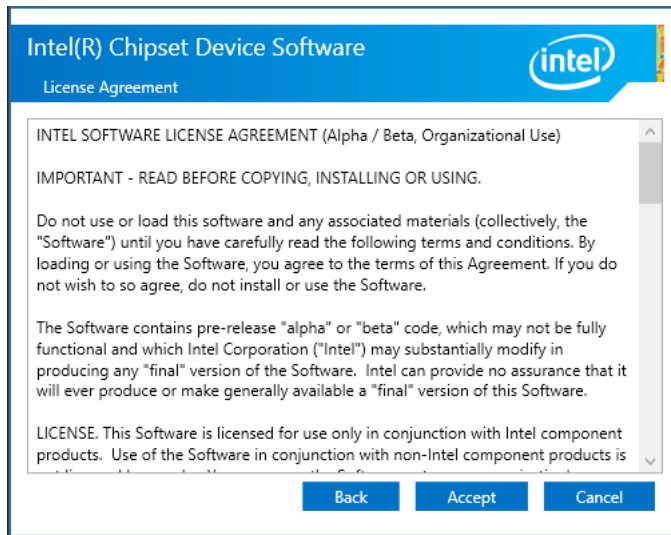

- Click **Install**.

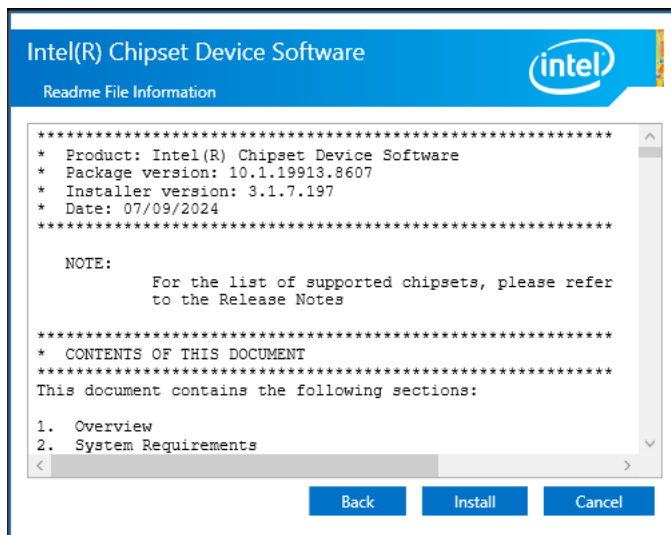

- Click **Restart Now**.



## B.2 Intel Management Engine Components Installation

Follow the steps below to install the Intel Management Engine Components:

1. Launch <Driver Root Path>\Intel\_CSME\_SW\_2524.8.11.0\_Corporate\Intel\_CSME\_SW\_2524.8.11.0\_Corporate\Installers\Main\_DCH
2. Install SetupMe.exe

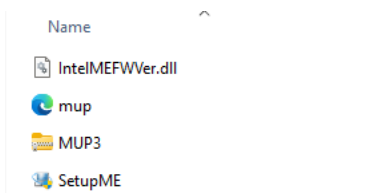

3. Click **Next**.

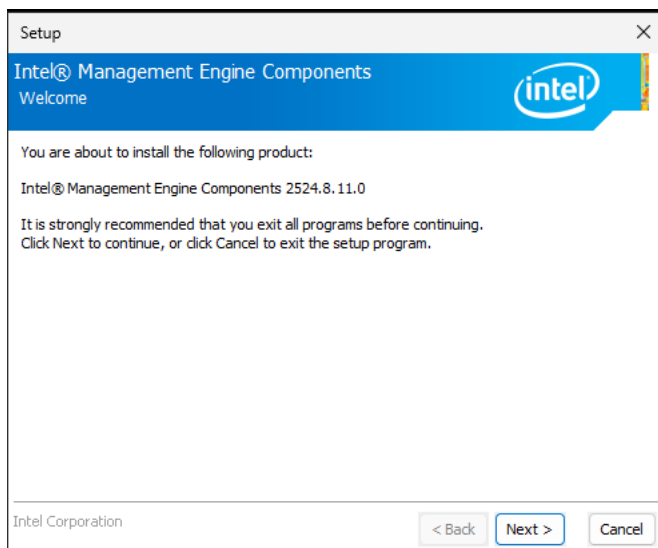

4. Check "I accept the terms in the License Agreement". Click **Next**.

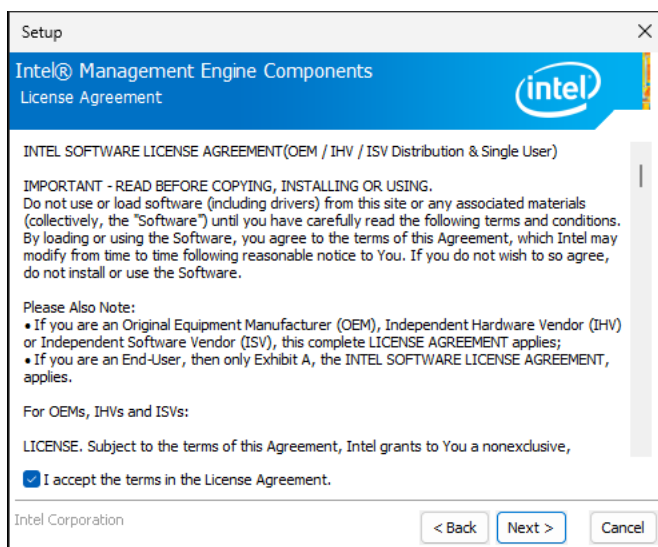

5. Click **Next**.

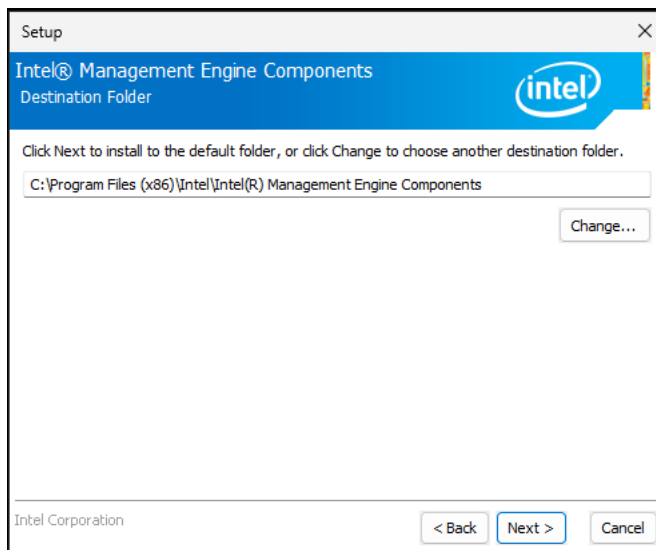

6. Click **Finish**.

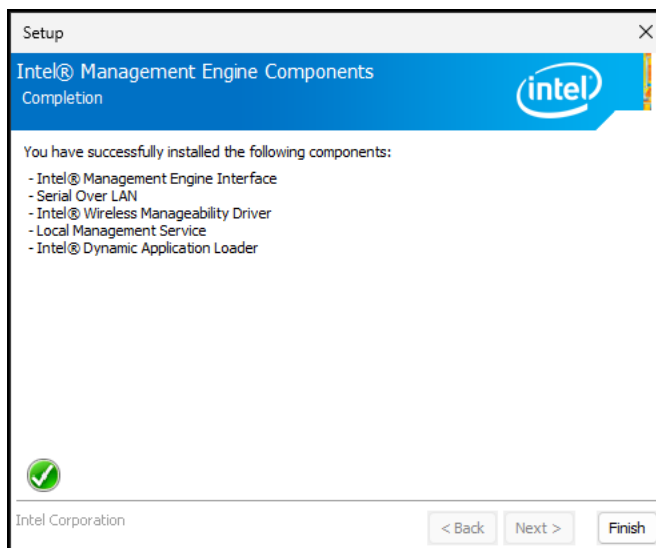

## B.3 Intel Graphics Driver Installation

Follow the steps below to install the Intel Graphics Driver:

1. Launch <Driver Root Path>\win64
2. Install Installer.exe

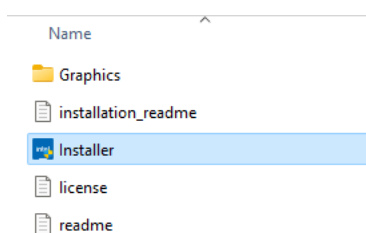

3. Click Begin Installation.

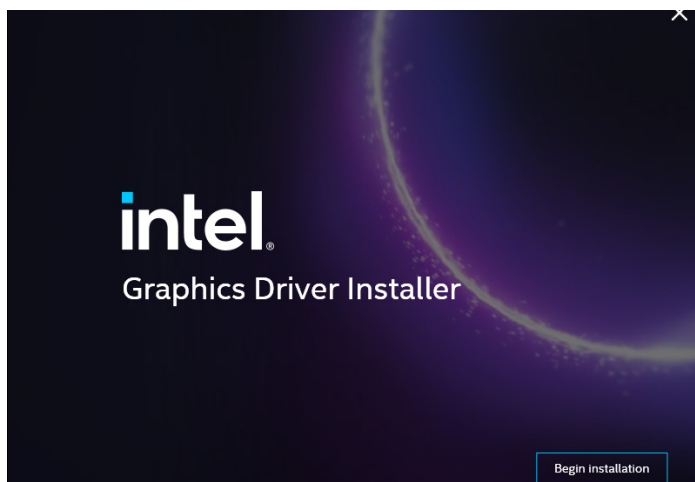

4. Click I agree.

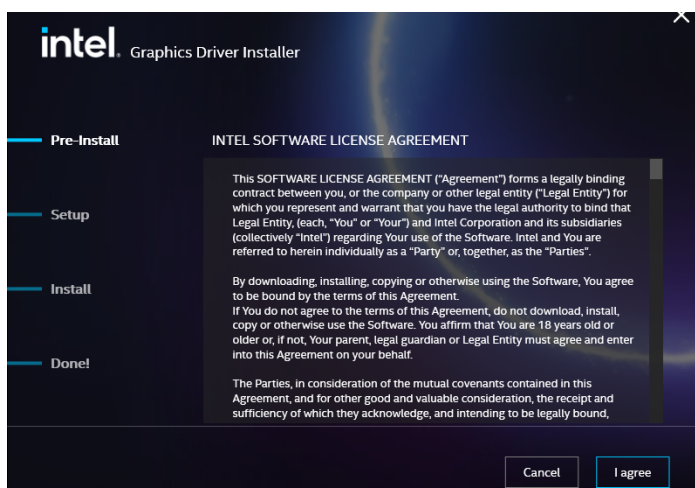

5. Click **Start**.

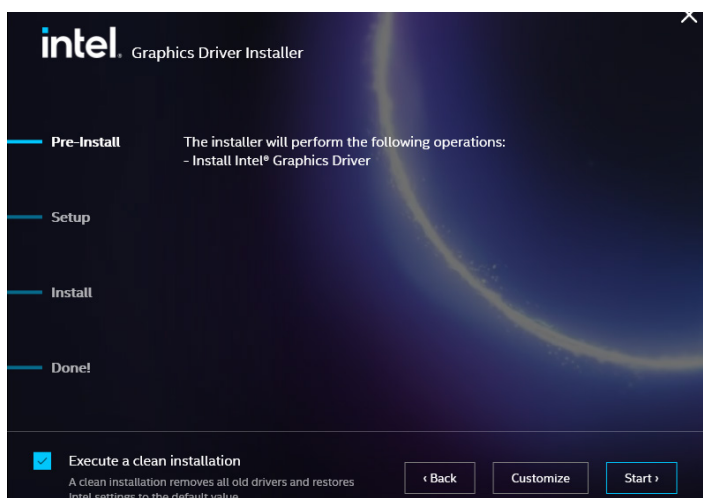

6. Click **Reboot Required**.

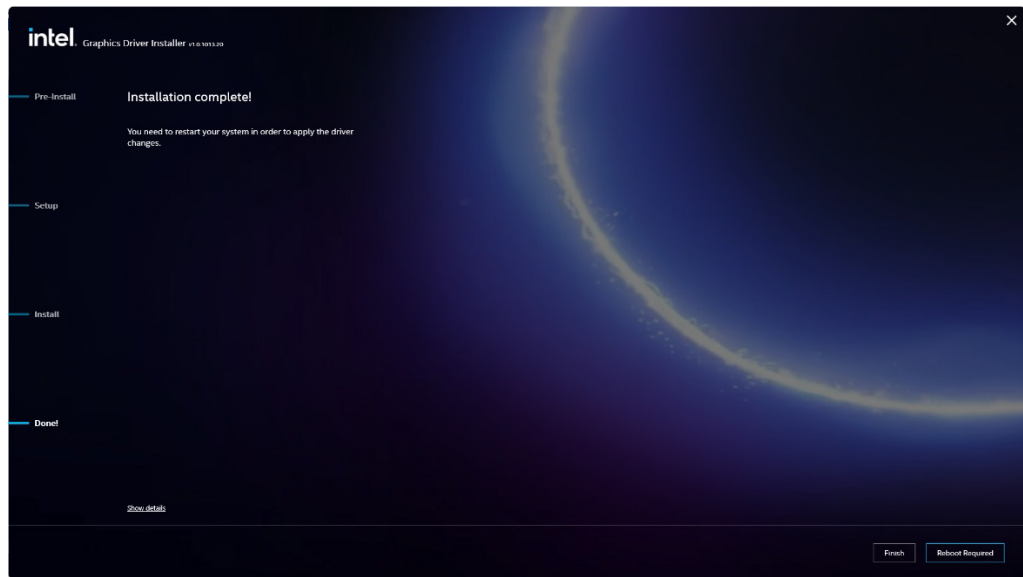

## B.4 Intel LAN Driver Installation

Follow the steps below to install the Intel LAN driver:

1. Launch <Driver Root Path>\Win11\Intel-I225-I226-NetAdapterCx-v2.1.4.2w
2. Select and right click **e2f.inf**. Click **Install** from the menu.

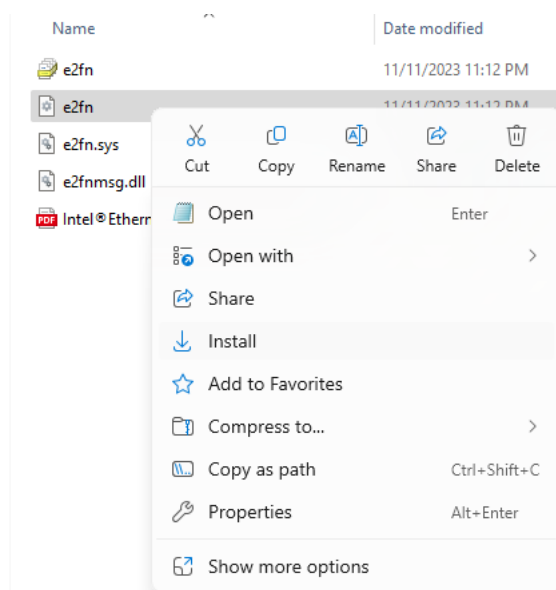

3. After installation, the following screen appears. Click **OK**.

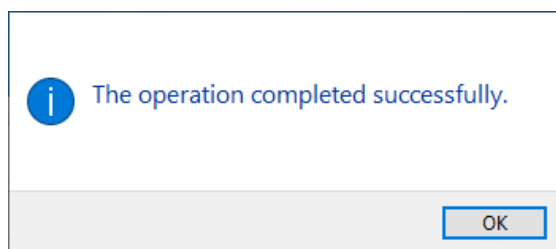

## B.5 Audio Driver Installation

Follow the steps below to install the Audio driver:

1. Launch <Driver Root Path>\9870\_UAD\_2025\_0806\_13FE
2. Install **setup.exe**

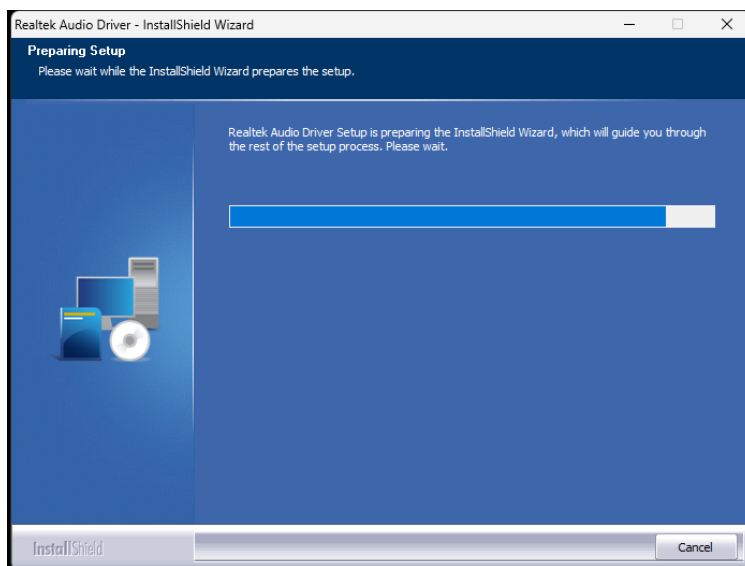

3. Click on **Next**

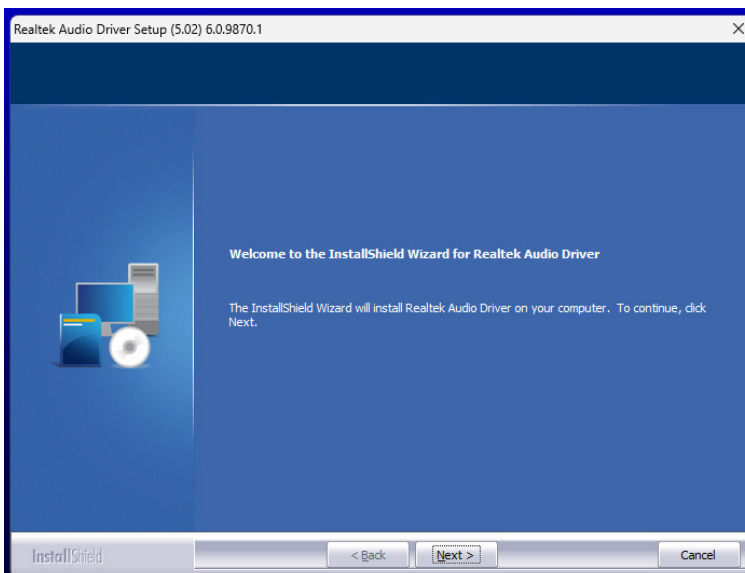

4. Select on **Yes, I want to restart my computer now**, and click on **Finish**.

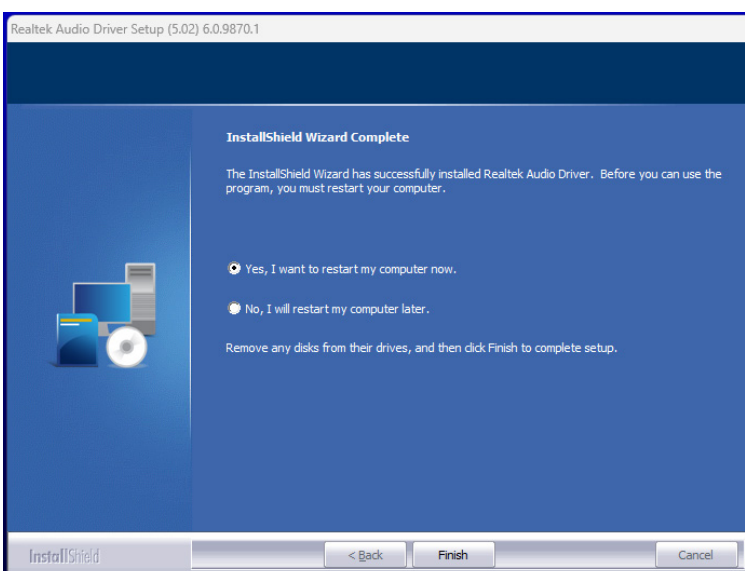

## B.6 Intel GNA Driver Installation

Follow the steps below to install the Intel GNA driver:

1. Launch <Driver Root Path>\gna-03.05.00.1578-pv-certified-20240904
2. Select and right click **gna.inf**. Click **Install** from the menu.

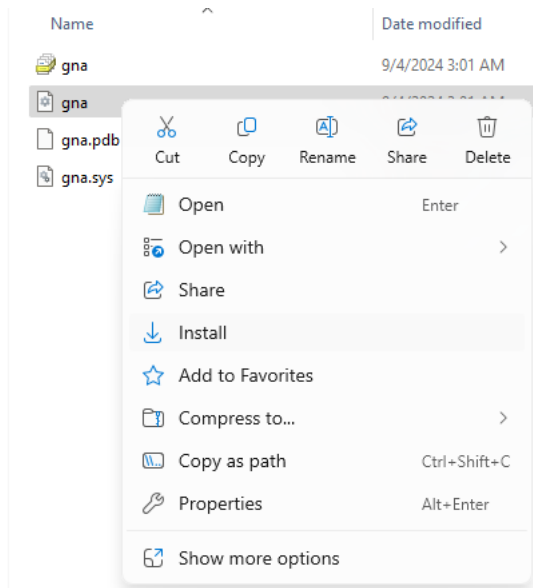

3. After installation, the following screen appears. Click **OK**.

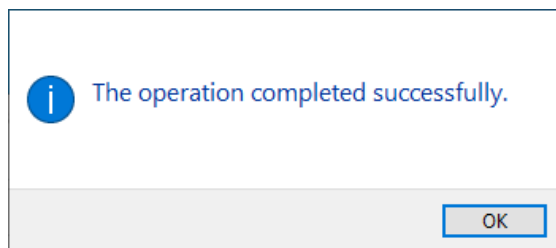

**ADVANTECH**

*Enabling an Intelligent Planet*

**[www.advantech.com](http://www.advantech.com)**

Please verify specifications before quoting. This guide is intended for reference purposes only.

All product specifications are subject to change without notice.

No part of this publication may be reproduced in any form or by any means, such as electronically, by photocopying, recording, or otherwise, without prior written permission from the publisher.

All brand and product names are trademarks or registered trademarks of their respective companies.

© Advantech Co., Ltd. 2026