

Industrial SD Card

3IE4 Series

Customer: _____
Customer
Part Number: _____
Innodisk
Part Number: _____
Innodisk
Model Name: _____
Date: _____

Innodisk Approver	Customer Approver

**Total Solution For
Industrial Flash Storage**

Table of contents

LIST OF FIGURES	6
1. PRODUCT OVERVIEW	7
1.1 INTRODUCTION OF INNODISK INDUSTRIAL SD 3IE4	7
1.2 PRODUCT VIEW AND MODELS	7
1.3 SD 6.1 INTERFACE	7
1.4 COMPATIBILITY	7
2. PRODUCT SPECIFICATIONS	8
2.1 CAPACITY AND DEVICE PARAMETERS.....	8
2.2 PERFORMANCE	8
2.3 ELECTRICAL SPECIFICATIONS	9
2.3.1 Power Requirement	9
2.3.2 Power Consumption.....	9
2.4 ENVIRONMENTAL SPECIFICATIONS	9
2.4.1 Temperature Ranges	9
2.4.2 Humidity	9
2.4.3 Shock and Vibration.....	9
2.4.4 Mean Time between Failures (MTBF).....	9
2.5 CE AND FCC COMPATIBILITY	10
2.6 RoHS COMPLIANCE	10
2.7 RELIABILITY	10
2.8 TRANSFER MODE	10
2.9 PIN ASSIGNMENT	11
2.10 MECHANICAL DIMENSIONS.....	11
2.11 ASSEMBLY WEIGHT.....	12
2.12 SEEK TIME	12
2.13 HOT PLUG	12
2.14 NAND FLASH MEMORY	12
2.15 CARD IDENTIFICATION REGISTER.....	12
2.16 SMART LIST.....	13
3. THEORY OF OPERATION	16
3.1 OVERVIEW.....	16
3.2 CONTROLLER.....	16
3.3 ERROR DETECTION AND CORRECTION.....	16
3.4 WEAR-LEVELING	16
3.5 BAD BLOCKS MANAGEMENT	17
3.6 GARBAGE COLLECTION.....	17
3.7 POWER CYCLING	17

4. INSTALLATION REQUIREMENTS	18
4.1 INDUSTRIAL SD CARD PIN DIRECTIONS	18
4.2 DEVICE DRIVE	18
5. PART NUMBER RULE	19

REVISION HISTORY

Revision	Description	Date
Preliminary 0.1	First release	May, 2021
V1.0	Official release	Nov.,2021
V1.1	Revised NAND Flash memory information	Jan., 2022
V1.2	Modify Operation Temperature (Standard grade: -20 to -25°C)	Jul., 2022
V1.3	Add 112-L 3D TLC	May., 2023
V1.4	Update Seq. workload of 100,000 P/E cycles(112-L)	Sep., 2023
V1.5	Add 4K Random R/W Performance for 112-L	Oct., 2023
V1.6	Remove EOL items	Aug., 2025
V1.7	Update theory of operation	Dec., 2025
V1.8	Remove EOL items	Jan., 2026
V1.9	Remove SD 2.0 & SD 1.1	Jun., 2026

List of Tables

TABLE 1: DEVICE PARAMETERS	8
TABLE 2: PERFORMANCE- 112 LAYERS 3D TLC*	8
TABLE 3: MEMORY CARD SPEED SPECIFICATION	8
TABLE 4: INNODISK INDUSTRIAL SD CARD POWER REQUIREMENT	9
TABLE 5: POWER CONSUMPTION	9
TABLE 6: TEMPERATURE RANGE FOR INDUSTRIAL SD CARD	9
TABLE 7: SHOCK/VIBRATION TESTING FOR INDUSTRIAL SD CARD	9
TABLE 8: INDUSTRIAL SD CARD MTBF	10
TABLE 9: SD CARD PIN ASSIGNMENT	11
TABLE 10: INNODISK INDUSTRIAL SD CARD CID TABLE	12
TABLE 11: SMART LIST	13

List of Figures

FIGURE 1: INNODISK INDUSTRIAL SD 3IE4	7
FIGURE 2: INNODISK INDUSTRIAL SD 3IE4 BLOCK DIAGRAM	16
FIGURE 3: SIGNAL SEGMENT AND POWER SEGMENT	18

1. Product Overview

1.1 Introduction of Innodisk Industrial SD 3IE4

Innodisk 3IE4 is an industrial-grade SD card solution with an integrated industrial controller, which is designed for embedded applications. With enhanced flash technologies and a powerful configurable LDPC ECC engine, SD 3IE4 can achieve high-speed data transfer rates.

Innodisk industrial SD 3IE4 are specifically designed for industrial PC and embedded applications for high performance. With its low power consumption and the above-mentioned features, Innodisk industrial SD 3IE4 can be applied for industrial automation, SBC (single-board computer), medical equipment, infotainment, and mobile applications.

1.2 Product View and Models

Innodisk Industrial SD 3IE4 is available from 8GB up to 64GB capacities within TLC Flash IC.

[SD 3IE4 16GB](#)

[SD 3IE4 32GB](#)

[SD 3IE4 64GB](#)



Figure 1: Innodisk Industrial SD 3IE4

1.3 SD 6.1 Interface

Innodisk Industrial SD 3IE4 is compliant with SD 6.1/ SD 3.0 interface.

1.4 Compatibility

Compliant Specifications

SD Memory Card Specifications

- Compliant with PHYSICAL LAYER SPECIFICATION Ver.6.01 or Ver.3.0. (Part1)
- Compliant with Card ADDENDUM SPECIFICATION Ver.2.00. (Part1)
- Compliant with FILE SYSTEM SPECIFICATION Ver.3.00. (Part2)
- Compliant with SECURITY SPECIFICATION Ver.3.00. (Part3)

2. Product Specifications

2.1 Capacity and Device Parameters

Innodisk Industrial SD card device parameters are shown in Table 1.

Table 1: Device parameters

Capacity	LBA
16GB	31167488
32GB	62334976
64GB	124669952

2.2 Performance

Burst Transfer Rate: up to 104 MB/s in SD 3.0 SDR104

Table 2: Performance- 112 Layers 3D TLC*

Capacity	Unit	16GB	32GB	64GB
Speed Class	Class	C10	C10	C10
UHS Class		U1	U1	U1
Video Speed Class		V10	V30	V30
Sequential Read (Q32T1)	MB/s	90	90	90
Sequential Write (Q32T1)		75	80	80
4KB Random** Read (Q32T1)	IOPS	2,000	2,000	2,000
4KB Random** Write (Q32T1)		1,200	1,200	1,200

Note: * Performance results are measured in Room Temperature with Out-of-Box devices and may vary depending on overall system setup.

Note: **Performance results are based on CrystalDiskMark 6.0.2 with file size 1000MB

Table 3: Memory Card Speed Specification

Minimum Sequential Write Speed	Speed Class	UHS Speed Class	Video Speed Class
30 MB/s		Class 30 (U3)	V30
10 MB/s	Class 10 (C10)	Class 10 (U1)	V10
6 MB/s	Class 6 (C6)		V6
4 MB/s	Class 4 (C4)		
2 MB/s	Class 2 (C2)		

2.3 Electrical Specifications

2.3.1 Power Requirement

Table 4: Innodisk Industrial SD card Power Requirement

Item	Symbol	Rating	Unit
Input voltage	V _{IN}	2.7V~3.6V	V

2.3.2 Power Consumption

Table 5: Power Consumption

Mode	Power Consumption (W)
Read (rms)	0.4
Write (rms)	0.5
Peak (max)	0.7
Idle (rms)	0.001

2.4 Environmental Specifications

2.4.1 Temperature Ranges

Table 6: Temperature range for Industrial SD card

Temperature	Range
Operating	Standard Grade: -25°C to +85°C
	Industrial Grade: -40°C to +85°C
Storage	-40°C to +85°C

2.4.2 Humidity

Relative Humidity: 10-95%, non-condensing

2.4.3 Shock and Vibration

Table 7: Shock/Vibration Testing for Industrial SD card

Reliability	Test Conditions	Reference Standards
Vibration	7 Hz to 2K Hz, 20G, 3 axes	IEC 60068-2-6
Mechanical Shock	Duration: 0.5ms, 1500 G, 3 axes	IEC 60068-2-27

2.4.4 Mean Time between Failures (MTBF)

Table 8 summarizes the MTBF prediction results for various Industrial SD card configurations. The analysis was performed using a RAM Commander™ failure rate prediction.

- **Failure Rate:** The total number of failures within an item population, divided by the total number of life units expended by that population, during a particular measurement interval

under stated condition.

- **Mean Time between Failures (MTBF):** A basic measure of reliability for repairable items: The mean number of life units during which all parts of the item perform within their specified limits, during a particular measurement interval under stated conditions.

Table 8: Industrial SD card MTBF

Product	Condition	MTBF (Hours)
Innodisk Industrial SD 3IE4	Telcordia SR-332 GB, 25°C	>3,000,000

2.5 CE and FCC Compatibility

Industrial SD 3IE4 conforms to CE and FCC requirements.

2.6 RoHS Compliance

Industrial SD 3IE4 is fully compliant with RoHS directive.

2.7 Reliability

Parameter	Value
Read Cycles	Unlimited Read Cycles
Flash endurance	30,000 P/E cycles; 100,000 P/E cycles(112-L)
Wear-Leveling Algorithm	Support
Bad Blocks Management	Support
Error Correct Code	Support
TBW* (Total Bytes Written) Unit:TB	
Capacity	Sequential workload
16GB	1420
32GB	2840
64GB	5680
*Note: Sequential: Mainly sequential write, tested by Vdbench.	

2.8 Transfer Mode

Industrial SD 3IE4 support following transfer mode:

SD 6.1/ SD 3.0

2.11 Assembly Weight

An Innodisk Industrial SD card 3.0 within TLC flash ICs, 64GB's weight is 9 grams approx.

2.12 Seek Time

Innodisk Industrial SD card is not a magnetic rotating design. There is no seek or rotational latency required.

2.13 Hot Plug

The SD card support hot plug function and can be removed or plugged-in during operation.

2.14 NAND Flash Memory

Innodisk Industrial SD 3IE4 uses 3D TLC NAND flash memory, which is non-volatility, high reliability and high speed memory storage.

2.15 Card Identification Register

The Card IDentification (CID) register is 128 bits wide. It contains the card identification information used during the card identification phase. Every individual flash card shall have a unique identification number. The structure of the CID register is defined in the following table

Table 10: Innodisk Industrial SD Card CID Table

CID bit	Width	Name	Field
[127:120]	8	Manufacturer ID	MID
[119:104]	16	OEM/Application ID	OID
[103:64]	40	Product Name	PNM
[63:56]	8	Product Revision	PRV
[55:24]	32	Product Serial Number	PSN
[23:20]	4	Reserved	---
[19:8]	12	Manufacturing Date	MDT
[7:1]	7	CRC7 check sum	CRC
[0]	1	Not used, always '1'	---

2.16 SMART List

Table 11: SMART List

Offset	Byte Count	Attribute Name	Description
0x000	16	Reserved for Unique ID/Setting	Reserved for Unique ID/Setting
0x010	1	Bus Width	00h: 1 bit width 10h: 4 bit width
0x011	1	Secured Mode	00h: Not in the secured mode 01h: In secured mode
0x012	1	Speed Class	00h: Class 0 01h: Class 2 02h: Class 4 03h: Class 6 04h: Class 10
0x013	1	UHS Speed Grade	00h: Less than 10MB/sec 01h: 10MB/sec and above 02h: Reserved 03h: 30MB/sec and above
0x014	4	Protected Area Size	Protected Area Size (Bytes)
0x018	2	Original Bad Block Count	Original Bad Block Count
0x01A	1	RTBB Count	Run-time Bad Block Count
0x01B	1	Total SLC Spare Count	Total SLC Spare Block Count
0x01C	4	Reserved	Reserved
0x020	4	Min. Erase Count (Data Block)	Minimum Erase Count (Data Block)(TLC Block)
0x024	4	Max. Erase Count (Data Block)	Maximum Erase Count (Data Block)(TLC Block)
0x028	4	Total Erase Count (Data Block)	Total Erase Count (Data Block)(TLC Block)
0x02C	4	Avg. Erase Count (Data Block)	Average Erase Count (Data Block)(TLC Block)
0x030	4	Min. Erase Count (System Table Block)	Minimum Erase Count (System Table Block)(SLC Block)

0x034	4	Max. Erase Count (System Table Block)	Maximum Erase Count (System Table Block)(SLC Block)
0x038	4	Total Erase Count (System Table Block)	Total Erase Count (System Table Block)(SLC Block)
0x03C	4	Avg. Erase Count (System Table Block)	Average Erase Count (System Table Block)(SLC Block)
0x040	4	Raw Card Capacity	Raw Card Capacity (MB)
0x044	2	NAND P/E Cycle	NAND P/E Cycle (unit : 100 times)(TLC Block)
0x046	1	Card Life (%)	Remaining Card Life (%) = (NAND P/E Cycle - Avg. Erase Count (MLC or TLC))/NAND P/E Cycle (TLC Block)
0x047	1	Current SD Card Speed Mode	0x00: Default speed 0x01: High speed mode 0x10: SDR12 0x11: SDR25 0x12: SDR50 0x14: DDR50 0x18: SDR104
0x048	4	Total Write CRC Count	Total Write CRC Count
0x04C	4	Power On/Off Count	Power On/Off Count
0x050	6	NAND Flash ID	NAND Flash ID (6 Bytes max.)(Only read flash ID for CE0)
0x056	1	MID	MID
0x057	1	Group Number	Group Number, ex. x4 with 4-way, group number=1, x4 with 2-way, group number=2
0x058	8	SMI SD Controller P/N	SMI SD Controller P/N (e.g. SM2706)
0x060	2	Read Claim Count (TLC Block)	Read Claim Count (Data on TLC Block) Host reads data on TLC Block and needs soft-decode case
0x062	2	Read Claim Count (SLC Block)	Read Claim Count (Data on SLC Block) Host

			reads data on SLC Block and needs soft-decode case
0x064	2	Firmware Block Refresh Counter	ISP Block refresh counter
0x066	2	Reserved	Reserved Area
0x068	4	TLC Read Count Threshold	TLC Read Count Threshold (unit : 100 times)
0x06C	4	SLC Read Count Threshold	SLC Read Count Threshold (unit : 100 times)
0x070	16	First TLC for each group	First TLC Block for each group
0x080	6	SD Firmware Version	SD Firmware Version (e.g. R0321x)
0x086	2	Reserved	Reserved Area
0x088	4	Data Refresh Count (TLC Block)	Data Refresh Count (TLC Block) Host reads data on TLC Block and read count is over TLC read count threshold case
0x08C	4	Data Refresh Count (SLC Block)	Data Refresh Count (SLC Block) Host reads data on SLC Block and read count is over SLC read count threshold case
0x090	16	CID Register	CID Register

3. Theory of Operation

3.1 Overview

Figure 2 shows the operation of Innodisk Industrial SD 3IE4 from the system level, including the major hardware blocks.

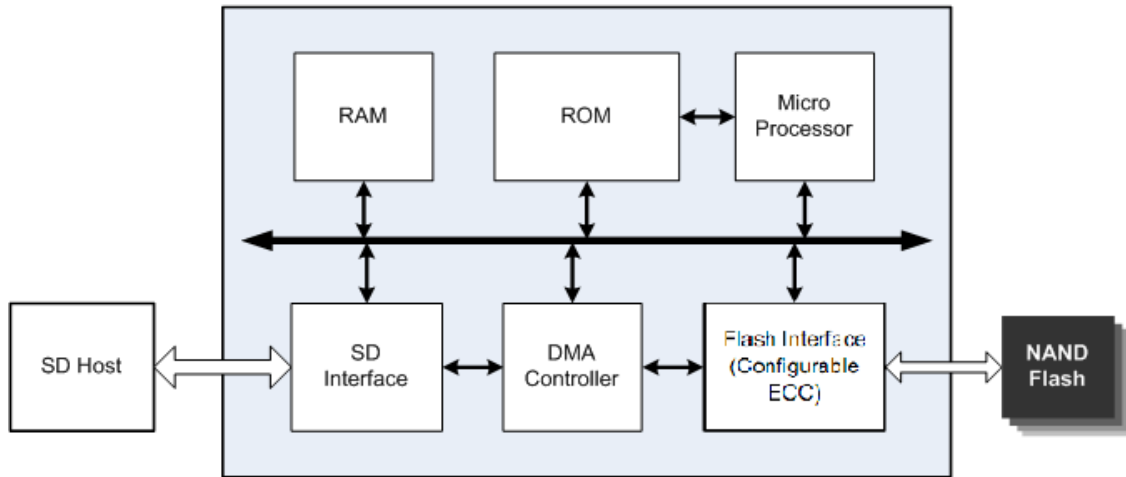

Figure 2: Innodisk Industrial SD 3IE4 Block Diagram

Innodisk Industrial SD 3IE4 integrates a SD 3.0 controller and NAND flash memories. Communication with the host occurs through the host interface, using the standard SD interface.

3.2 Controller

Innodisk Industrial SD 3IE4 is designed with a SD 3.0 controller, which has single channel for flash interface.

3.3 Error Detection and Correction

Innodisk SD 3IE4 is designed with hardware LDPC ECC engine with hard-decision and soft-decision decoding. Low-density parity-check (LDPC) codes have excellent error correcting performance close to the Shannon limit when decoded with the belief-propagation (BP) algorithm using soft-decision information.

3.4 Wear-Leveling

Flash memory can be erased within a limited number of times. This number is called the **erase cycle limit** or **write endurance limit** and is defined by the flash array vendor. The erase cycle limit applies to each individual erase block in the flash device.

Innodisk Industrial SD 3IE4 uses a global wear-leveling algorithm to ensure that consecutive writes of a specific sector are not written physically to the same page/block in the flash. This spreads flash media usage evenly across all pages, thereby extending flash lifetime.

3.5 Bad Blocks Management

Bad Blocks are blocks that contain one or more invalid bits whose reliability are not guaranteed. The Bad Blocks may be presented while the product is shipped, or may develop during the life time of the SD card. When the Bad Blocks is detected, it will be flagged, and not be used anymore. The SD card implement Bad Blocks management, Bad Blocks replacement, Error Correct Code to avoid data error occurred. The functions will be enabled automatically to transfer data from Bad Blocks to spare blocks, and correct error bit.

3.6 Garbage Collection

Garbage collection is used to maintain data consistency and perform continual data cleansing on SD card. It runs as a background process, freeing up valuable controller resources while sorting good data into available blocks, and deleting bad blocks. It also significantly reduces write operations to the drive, thereby increasing the SD's speed and lifespan.

3.7 Power cycling

Innodisk's SD/MSDs provide the complete data protection mechanism during every abnormal power shutdown situation. Such as: power failure at programming data, updating system tables, erasing blocks, etc. The mechanism can maintain the data correctness and increase the reliability of the data stored in the NAND Flash memory.

4. Installation Requirements

4.1 Industrial SD card Pin Directions

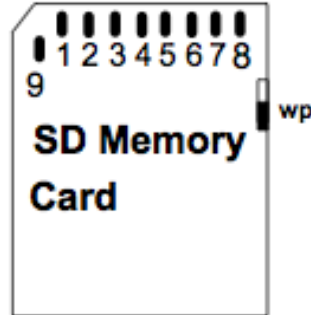

Figure 3: Signal Segment and Power Segment

4.2 Device Drive

No additional device drives are required.

5. Part Number Rule

CODE	1	2	3	4	5	6	7	8	9	10	11	12	13	14	15	16	17	18	19	20
	D	H	S	D	C	-	6	4	G	S	0	6	K	E	1	S	L	-	X	X
Definition																				
Code 1 st (Disk)										Code 13 th (Flash Mode)										
D: Disk										K: 112 layers 3D TLC										
Code 2 nd ~ 5 th (Form Factor)										Code 14 th (Operation Temperature)										
HSDC: Industrial SD Card										E: Extended Grade (-25°C~ +85°C)										
Code 7 th ~9 th (Capacity)										Code 15 th (Internal control)										
16G: 16GB										1: Product version										
32G: 32GB										Code 16 th (Channel of data transfer)										
64G: 64GB										S: Single Channel										
Code 10 th ~12 th (Series)										Code 17 th (Flash Type)										
S06: 3IE4 Series										L: Innodisk 3D TLC										
Code 19 th ~20 th (Customized Code)																				