

# MicroSD Card

## 3TE4 Series

**Customer:** \_\_\_\_\_  
**Customer**  
**Part Number:** \_\_\_\_\_  
**Innodisk**  
**Part Number:** \_\_\_\_\_  
**Innodisk**  
**Model Name:** \_\_\_\_\_  
**Date:** \_\_\_\_\_

<b>Innodisk Approver</b>	<b>Customer Approver</b>

**Total Solution For  
Industrial Flash Storage**

## Table of contents

<b>1. PRODUCT OVERVIEW .....</b>	<b>6</b>
<b>1.1 INTRODUCTION OF MICROSD 3TE4.....</b>	<b>6</b>
<b>1.2 PRODUCT VIEW AND MODELS.....</b>	<b>6</b>
<b>1.3 SD 3.0 INTERFACE .....</b>	<b>6</b>
<b>1.4 COMPATIBILITY .....</b>	<b>6</b>
<b>2. PRODUCT SPECIFICATIONS.....</b>	<b>7</b>
<b>2.1 CAPACITY AND DEVICE PARAMETERS.....</b>	<b>7</b>
<b>2.2 PERFORMANCE .....</b>	<b>7</b>
<b>2.3 ELECTRICAL SPECIFICATIONS.....</b>	<b>8</b>
<b>2.3.1 Power Requirement .....</b>	<b>8</b>
<b>2.3.2 Power Consumption.....</b>	<b>8</b>
<b>2.4 ENVIRONMENTAL SPECIFICATIONS .....</b>	<b>8</b>
<b>2.4.1 Temperature Ranges .....</b>	<b>8</b>
<b>2.4.2 Shock and Vibration.....</b>	<b>8</b>
<b>2.4.3 Mean Time between Failures (MTBF).....</b>	<b>8</b>
<b>2.5 CE AND FCC COMPATIBILITY .....</b>	<b>9</b>
<b>2.6 RoHS COMPLIANCE .....</b>	<b>9</b>
<b>2.7 RELIABILITY .....</b>	<b>9</b>
<b>2.8 TRANSFER MODE .....</b>	<b>9</b>
<b>2.9 PIN ASSIGNMENT .....</b>	<b>10</b>
<b>2.10 MECHANICAL DIMENSIONS.....</b>	<b>11</b>
<b>2.11 ASSEMBLY WEIGHT .....</b>	<b>11</b>
<b>2.12 SEEK TIME .....</b>	<b>11</b>
<b>2.13 NAND FLASH MEMORY.....</b>	<b>11</b>
<b>2.14 CARD IDENTIFICATION REGISTER .....</b>	<b>12</b>
<b>2.15 SMART LIST.....</b>	<b>12</b>
<b>3. THEORY OF OPERATION .....</b>	<b>16</b>
<b>3.1 OVERVIEW.....</b>	<b>16</b>
<b>3.2 CONTROLLER.....</b>	<b>16</b>
<b>3.3 ERROR DETECTION AND CORRECTION.....</b>	<b>16</b>
<b>3.4 WEAR-LEVELING .....</b>	<b>17</b>
<b>3.5 BAD BLOCKS MANAGEMENT .....</b>	<b>17</b>
<b>3.6 GARBAGE COLLECTION.....</b>	<b>17</b>
<b>4. PART NUMBER RULE .....</b>	<b>18</b>

## REVISION HISTORY

Revision	Description	Date
V1.0	Official release	Sep.,2021
V1.1	Revised NAND Flash memory information	Jan., 2022
V1.2	Revised LBA table	Jan., 2022
V1.3	Add 112-L 3D TLC	Nov., 2022
V1.4	Add 112-L 512GB	Apr., 2023
V1.5	Remove EOL items	Aug., 2025
V1.6	Update theory of operation	Dec., 2025
V1.7	Remove EOL items	Jan., 2026
V1.8	Remove SD 2.0 & SD 1.1	Jun., 2026

## List of Tables

<b>TABLE 1: DEVICE PARAMETERS</b> .....	7
<b>TABLE 2: PERFORMANCE</b> .....	7
<b>TABLE 3: MEMORY CARD SPEED SPECIFICATION</b> .....	7
<b>TABLE 4: INNODISK MICROSD 3TE4 POWER REQUIREMENT</b> .....	8
<b>TABLE 5: TYPICAL POWER CONSUMPTION</b> .....	8
<b>TABLE 6: TEMPERATURE RANGE FOR MICROSD 3TE4</b> .....	8
<b>TABLE 7: SHOCK/VIBRATION TESTING FOR MICROSD 3TE4</b> .....	8
<b>TABLE 8: MICROSD 3TE4 MTBF</b> .....	9
<b>TABLE 9: INNODISK MICROSD 3TE4 PAD ASSIGNMENT</b> .....	10
<b>TABLE 10 INNODISK INDUSTRIAL SD CARD CID TABLE</b> .....	12
<b>TABLE 11. SMART LIST</b> .....	12

## List of Figures

**FIGURE 1: INNODISK MICROSD 3TE4 AND HOST BLOCK DIAGRAM.....16**

# 1. Product Overview

## 1.1 Introduction of MicroSD 3TE4

Innodisk MicroSD 3TE4 is designed for demanding industrial applications and provides excellent performance. Moreover, Innodisk MicroSD 3TE4 supports Ultra High Speed (UHS) interface transfer mode, provides high write/read data transfer rate, high random IOPS, sudden Power-Fails protection, adaptive static wear-leveling, read/program disturb management, etc.

## 1.2 Product View and Models

Innodisk MicroSD 3TE4 is available in follow capacities within TLC flash ICs.

[MicroSD 3TE4 64GB](#)

[MicroSD 3TE4 128GB](#)

[MicroSD 3TE4 256GB](#)

[MicroSD 3TE4 512GB](#)



## 1.3 SD 3.0 Interface

Innodisk MicroSD 3TE4 is compliant with SD 6.1/ SD 3.0 interface.

## 1.4 Compatibility

Compliant Specifications

SD Memory Card Specifications

- Compliant with PHYSICAL LAYER SPECIFICATION Ver.6.01 or Ver.3.0. (Part1)
- Compliant with Card ADDENDUM SPECIFICATION Ver.2.00. (Part1)
- Compliant with FILE SYSTEM SPECIFICATION Ver.3.00. (Part2)
- Compliant with SECURITY SPECIFICATION Ver.3.00. (Part3)

## 2. Product Specifications

### 2.1 Capacity and Device Parameters

MicroSD 3TE4 device parameters are shown in Table 1.

**Table 1: Device parameters**

Capacity	LBA
64GB	122159104
128GB	244318208
256GB	488636416
512GB	977272832

### 2.2 Performance

Burst Transfer Rate: UHS-I (up to 104 MB/s in SD 3.0 SDR104)

**Table 2: Performance**

Capacity	64GB	128GB	256GB	512GB
<b>Speed Class</b>	C10	C10	C10	C10
<b>UHS Class</b>	U1	U3	U3	U3
<b>Video Speed Class</b>	V10	V30	V30	V30
<b>Sequential Read (max.)</b>	90 MB/s	90 MB/s	90 MB/s	90 MB/s
<b>Sequential Write (max.)</b>	40 MB/s	80 MB/s	80 MB/s	80 MB/s

Note: \* Performance results are measured in Room Temperature with Out-of-Box devices and may vary depending on overall system setup.

Note: \*\*Performance results are based on CrystalDiskMark 6.0.2 with file size 1000MB

**Table 3: Memory Card Speed Specification**

Minimum Sequential Write Speed	Speed Class	UHS Speed Class	Video Speed Class
30 MB/s		Class 30 (U3)	V30
10 MB/s	Class 10 (C10)	Class 10 (U1)	V10
6 MB/s	Class 6 (C6)		V6
4 MB/s	Class 4 (C4)		
2 MB/s	Class 2 (C2)		

## 2.3 Electrical Specifications

### 2.3.1 Power Requirement

**Table 4: Innodisk MicroSD 3TE4 Power Requirement**

Item	Symbol	Rating	Unit
Input voltage	V <sub>IN</sub>	2.7~3.6	V

### 2.3.2 Power Consumption

**Table 5: Typical Power Consumption**

Mode	Power Consumption (W)
Read (rms)	0.6
Write (rms)	0.7
Idle (rms)	0.003
Peak (max)	1.4

## 2.4 Environmental Specifications

### 2.4.1 Temperature Ranges

**Table 6: Temperature range for MicroSD 3TE4**

Temperature	Range
Operating	Standard Grade: -25°C to +85°C Industrial Grade: -40°C to +85°C
Storage	-40°C to +85°C

### 2.4.2 Shock and Vibration

**Table 7: Shock/Vibration Testing for MicroSD 3TE4**

Reliability	Test Conditions	Reference Standards
Vibration	7 Hz to 2K Hz, 20G, 3 axes	IEC 60068-2-6
Mechanical Shock	Duration: 0.5ms, 1500 G, 3 axes	IEC 60068-2-27

### 2.4.3 Mean Time between Failures (MTBF)

Table 7 summarizes the MTBF prediction results for various MicroSD 3TE4 configurations. The analysis was performed using a RAM Commander™ failure rate prediction.

- **Failure Rate:** The total number of failures within an item population, divided by the total number of life units expended by that population, during a particular measurement interval under stated condition.
- **Mean Time between Failures (MTBF):** A basic measure of reliability for repairable items:

The mean number of life units during which all parts of the item perform within their specified limits, during a particular measurement interval under stated conditions.

**Table 8: MicroSD 3TE4 MTBF**

Product	Condition	MTBF (Hours)
Innodisk MicroSD 3TE4	Telcordia SR-332 GB, 25°C	>3,000,000

## 2.5 CE and FCC Compatibility

MicroSD 3TE4 conforms to CE and FCC requirements.

## 2.6 RoHS Compliance

MicroSD 3TE4 is fully compliant with RoHS directive.

## 2.7 Reliability

Parameter	Value
Read Cycles	Unlimited Read Cycles
Flash endurance	3,000 P/E cycles
Wear-Leveling Algorithm	Support
Bad Blocks Management	Support
Error Correct Code	Support
<b>TBW* (Total Bytes Written) Unit:TB</b>	
<b>Capacity</b>	<b>Sequential workload</b>
64GB	170.45
128GB	340.90
256GB	681.81
512GB	1363.63
*Note: Sequential: Mainly sequential write, tested by Vdbench.	

## 2.8 Transfer Mode

MicroSD 3TE4 supports following transfer mode:

SD 6.1

SD 3.0

SPI mode

## 2.9 Pin Assignment

MicroSD 3TE4 uses a standard SD pin-out. See Table 10 for MicroSD 3TE4 pad assignment.

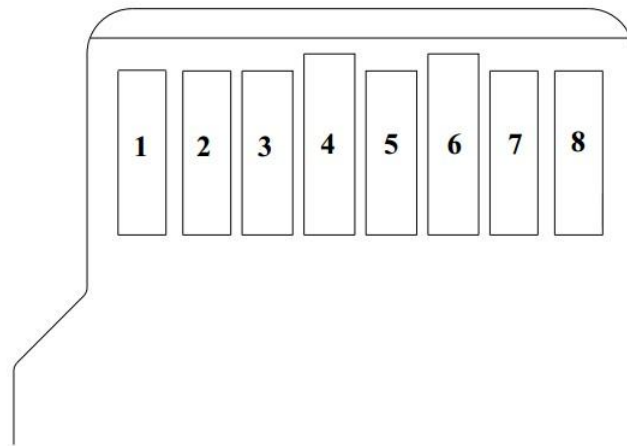

**Table 9: Innodisk MicroSD 3TE4 Pad Assignment**

Pin #	Name	Type	description
1	DAT <sup>2,5</sup>	I/O	Data Line [Bit 2]
2	CD/DAT <sup>3,2</sup>	I/O <sup>3</sup>	Card Detect/Data Line[Bit 3]
3	CMD	I/O	Command/Response
4	V <sub>DD</sub>	S	S Supply Voltage
5	CLK	I	Clock
6	V <sub>SS</sub>	S	S Supply Voltage GND
7	DAT <sup>0</sup>	I/O	Data Line [Bit 0]
8	DAT <sup>1,4</sup>	I/O	Data Line [Bit 1]

## 2.10 Mechanical Dimensions

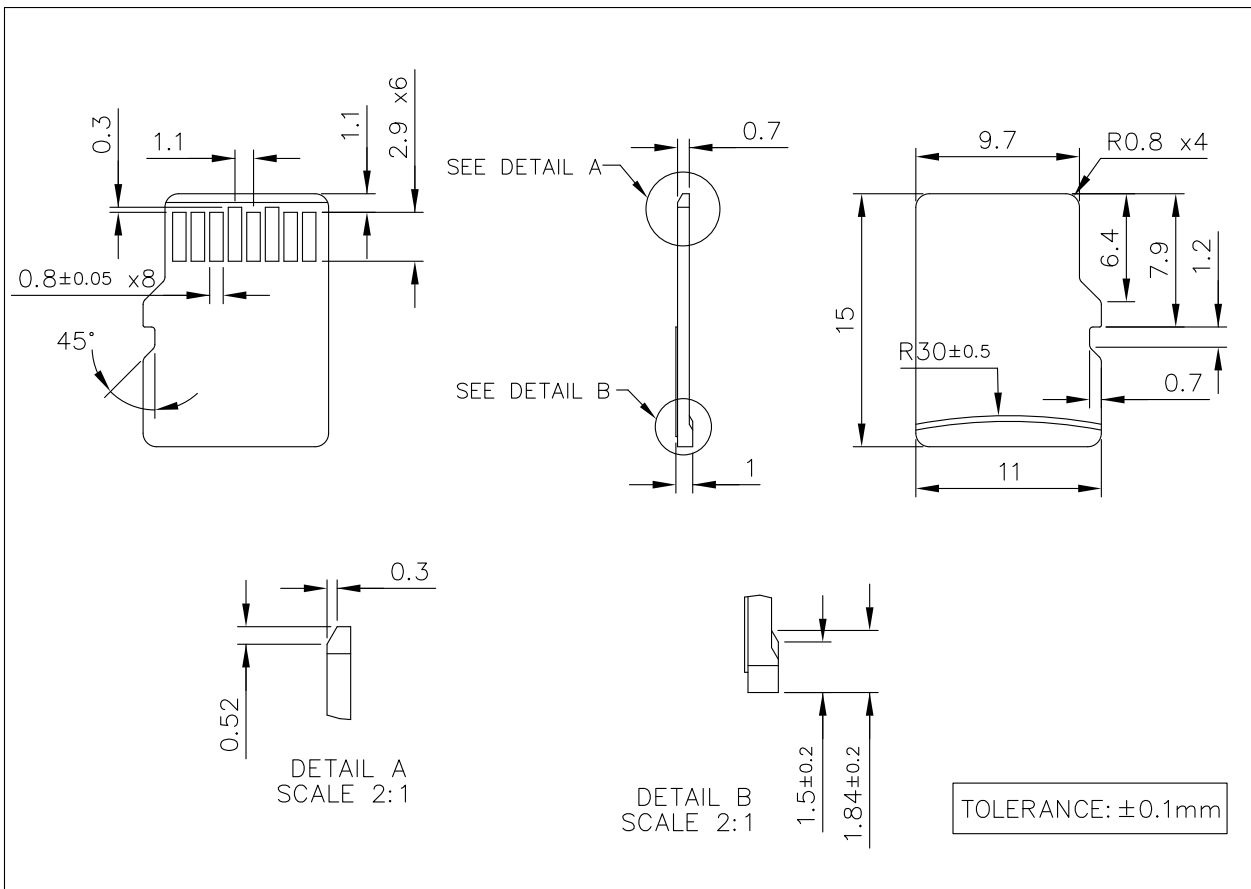

## 2.11 Assembly Weight

An Innodisk MicroSD 3TE4 within flash ICs weight is 0.25 grams approximately.

## 2.12 Seek Time

Innodisk MicroSD 3TE4 is not a magnetic rotating design. There is no seek or rotational latency required.

## 2.13 NAND Flash Memory

Innodisk MicroSD 3TE4 uses 3D TLC NAND flash memory, which is non-volatility, high reliability and high speed memory storage. Each cell stores 3 bits per cell. Read or Write data to flash memory for SD/MSD is control by microprocessor.

## 2.14 Card Identification Register

The Card IDentification (CID) register is 128 bits wide. It contains the card identification information used during the card identification phase. Every individual flash card shall have a unique identification number. The structure of the CID register is defined in the following table.

**Table 10 Innodisk Industrial SD Card CID Table**

CID bit	Width	Name	Field
[127:120]	8	Manufacturer ID	MID
[119:104]	16	OEM/Application ID	OID
[103:64]	40	Product Name	PNM
[63:56]	8	Product Revision	PRV
[55:24]	32	Product Serial Number	PSN
[23:20]	4	Reserved	---
[19:8]	12	Manufacturing Date	MDT
[7:1]	7	CRC7 check sum	CRC
[0]	1	Not used, always '1'	---

## 2.15 SMART List

**Table 11. SMART List**

Offset	Byte Count	Attribute Name	Description
0x000	16	Reserved for Unique ID/Setting	Reserved for Unique ID/Setting
0x010	1	Bus Width	00h: 1 bit width 10h: 4 bit width
0x011	1	Secured Mode	00h: Not in the secured mode 01h: In secured mode
0x012	1	Speed Class	00h: Class 0 01h: Class 2 02h: Class 4 03h: Class 6 04h: Class 10
0x013	1	UHS Speed Grade	00h: Less than 10MB/sec 01h: 10MB/sec and above 02h: Reserved 03h: 30MB/sec and above

Offset	Byte Count	Attribute Name	Description
0x014	4	Protected Area Size	Protected Area Size (Bytes)
0x018	2	Original Bad Block Count	Original Bad Block Count
0x01A	1	RTBB Count	Run-time Bad Block Count
0x01B	1	Total SLC Spare Count	Total SLC Spare Block Count
0x01C	4	Reserved	Reserved
0x020	4	Min. Erase Count (Data Block)	Minimum Erase Count (Data Block)(TLC Block)
0x024	4	Max. Erase Count (Data Block)	Maximum Erase Count (Data Block)(TLC Block)
0x028	4	Total Erase Count (Data Block)	Total Erase Count (Data Block)(TLC Block)
0x02C	4	Avg. Erase Count (Data Block)	Average Erase Count (Data Block)(TLC Block)
0x030	4	Min. Erase Count (System Table Block)	Minimum Erase Count (System Table Block)(SLC Block)
0x034	4	Max. Erase Count (System Table Block)	Maximum Erase Count (System Table Block)(SLC Block)
0x038	4	Total Erase Count (System Table Block)	Total Erase Count (System Table Block)(SLC Block)
0x03C	4	Avg. Erase Count (System Table Block)	Average Erase Count (System Table Block)(SLC Block)
0x040	4	Raw Card Capacity	Raw Card Capacity (MB)
0x044	2	NAND P/E Cycle	NAND P/E Cycle (unit : 100 times )(TLC Block)
0x046	1	Card Life (%)	Remaining Card Life (%) = (NAND P/E Cycle - Avg. Erase Count (MLC or TLC))/NAND P/E Cycle (TLC Block)
0x047	1	Current SD Card Speed Mode	0x00: Default speed 0x01: High speed mode  0x10: SDR12

Offset	Byte Count	Attribute Name	Description
0x047	1	Current SD Card Speed Mode	0x11: SDR25 0x12: SDR50 0x14: DDR50 0x18: SDR104
0x048	4	Total Write CRC Count	Total Write CRC Count
0x04C	4	Power On/Off Count	Power On/Off Count
0x050	6	NAND Flash ID	NAND Flash ID (6 Bytes max.)(Only read flash ID for CE0)
0x056	1	MID	MID
0x057	1	Group Number	Group Number, ex. x4 with 4-way, group number=1, x4 with 2-way, group number=2
0x058	8	SMI SD Controller P/N	SMI SD Controller P/N (e.g. SM2706)
0x060	2	Read Claim Count (TLC Block)	Read Claim Count (Data on TLC Block) Host reads data on TLC Block and needs soft-decode case
0x062	2	Read Claim Count (SLC Block)	Read Claim Count (Data on SLC Block) Host reads data on SLC Block and needs soft-decode case
0x064	2	Firmware Block Refresh Counter	ISP Block refresh counter
0x066	2	Reserved	Reserved Area
0x068	4	TLC Read Count Threshold	TLC Read Count Threshold ( unit : 100 times )
0x06C	4	SLC Read Count Threshold	SLC Read Count Threshold ( unit : 100 times )
0x070	16	First TLC for each group	First TLC Block for each group
0x080	6	SD Firmware Version	SD Firmware Version (e.g. R0321x)
0x086	2	Reserved	Reserved Area
0x088	4	Data Refresh Count (TLC Block)	Data Refresh Count (TLC Block) Host reads data on TLC Block and read count is over TLC read count threshold case

<b>Offset</b>	<b>Byte Count</b>	<b>Attribute Name</b>	<b>Description</b>
0x08C	4	Data Refresh Count (SLC Block)	Data Refresh Count (SLC Block) Host reads data on SLC Block and read count is over SLC read count threshold case
0x090	16	CID Register	CID Register

## 3. Theory of Operation

### 3.1 Overview

Figure 1 shows the operation of Innodisk MicroSD 3TE4 from the system level, including the major hardware blocks.

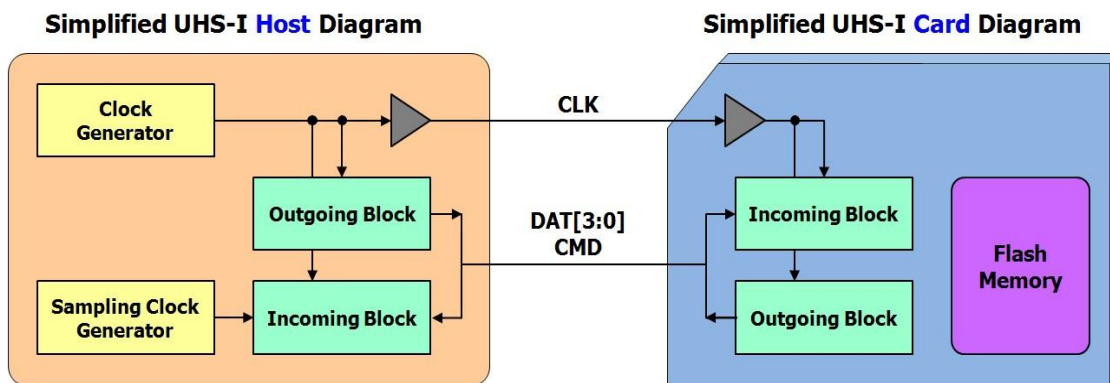

**Figure 1: Innodisk MicroSD 3TE4 and Host Block Diagram**

Figure 1 shows a typical UHS-I host system that supports removable cards. Host has clock generator which supplies SDCLK to the card. In case of write operation, as clock direction and data direction is the same, write data can be transferred synchronized with SDCLK regardless of transmission line delay.

In case of read operation, as clock direction and data direction is opposite, read data host received is delayed by round-trip delay, output delay and latency of host and card. So, receiving data is the most critical for the host. Therefore, host needs to have sampling clock generator to receive response, CRC status and read data block.

### 3.2 Controller

Innodisk MicroSD 3TE4 is designed with a SD 3.0 controller.

### 3.3 Error Detection and Correction

Innidisk MicroSD 3TE4 is designed with hardware LDPC ECC engine with hard-decision and soft-decision decoding. Low-density parity-check (LDPC) codes have excellent error correcting performance close to the Shannon limit when decoded with the belief-propagation (BP) algorithm using soft-decision information.

### **3.4 Wear-Leveling**

Global and static wear-leveling provides more uniform block usage than dynamic and Zone-based wear-leveling. The essence had scrambled entire blocks to reach the unique probability of P/E cycle and quite longer lifetime.

Innodisk's wear-leveling scheme is accomplished by global adaptive static wear-leveling, which ensures the better endurance and optimizes the system performance of the Flash memory array.

### **3.5 Bad Blocks Management**

Bad Blocks are blocks that contain one or more invalid bits whose reliability are not guaranteed. The Bad Blocks may be presented while the SD/MSD is shipped, or may develop during the life time of the SD/MSD. When the Bad Blocks is detected, it will be flagged, and not be used anymore. The SD/MSD implement Bad Blocks management, Bad Blocks replacement, Error Correct Code to avoid data error occurred. The functions will be enabled automatically to transfer data from Bad Blocks to spare blocks, and correct error bit.

### **3.6 Garbage Collection**

Garbage collection is used to maintain data consistency and perform continual data cleansing on SD/MSDs. It frees up valuable controller resources while sorting good data into available blocks, and deletes bad blocks. It also significantly reduces write operations to the drive, thereby increasing the SD/MSD's speed and lifespan.

### **3.7 Power cycling**

Innodisk's SD/MSDs provide the complete data protection mechanism during every abnormal power shutdown situation. Such as: power failure at programming data, updating system tables, erasing blocks, etc. The mechanism can maintain the data correctness and increase the reliability of the data stored in the NAND Flash memory.

## 4. Part Number Rule

CODE	1	2	3	4	5	6	7	8	9	10	11	12	13	14	15	16	17	18	19	20	21
	D	E	S	D	M	-	A	2	8	S	0	6	K	E	1	S	L	-	X	X	X
<b>Definition</b>																					
<b>Code 1<sup>st</sup> (Disk)</b>											<b>Code 13<sup>th</sup> (Flash Mode)</b>										
D: Disk											K: 112 layers 3D TLC										
<b>Code 2<sup>nd</sup> ~ 5<sup>th</sup> (Form Factor)</b>											<b>Code 14<sup>th</sup> (Operation Temperature)</b>										
ESDM: MicroSD											E: Extended Grade (-25°C~ +85°C)										
											W: Industrial Grade (-40°C~ +85°C)										
<b>Code 7<sup>th</sup> ~9<sup>th</sup> (Capacity)</b>											<b>Code 15<sup>th</sup> (Internal control)</b>										
64G: 64GB											1: Product version										
A28: 128GB											<b>Code 16<sup>th</sup> (Channel of data transfer)</b>										
B56: 256GB											S: Single Channel										
C12: 512GB											<b>Code 17<sup>th</sup></b>										
											L: Innodisk 3D TLC										
<b>Code 10<sup>th</sup> ~12<sup>th</sup> (Controller)</b>											<b>Code 19<sup>th</sup>~21<sup>th</sup> (Customized Code)</b>										
S06: 3TE4 Series																					